

C. C. CLOVER.
Sulky-Plow.

No. 212,193.

Patented Feb. 11, 1879.

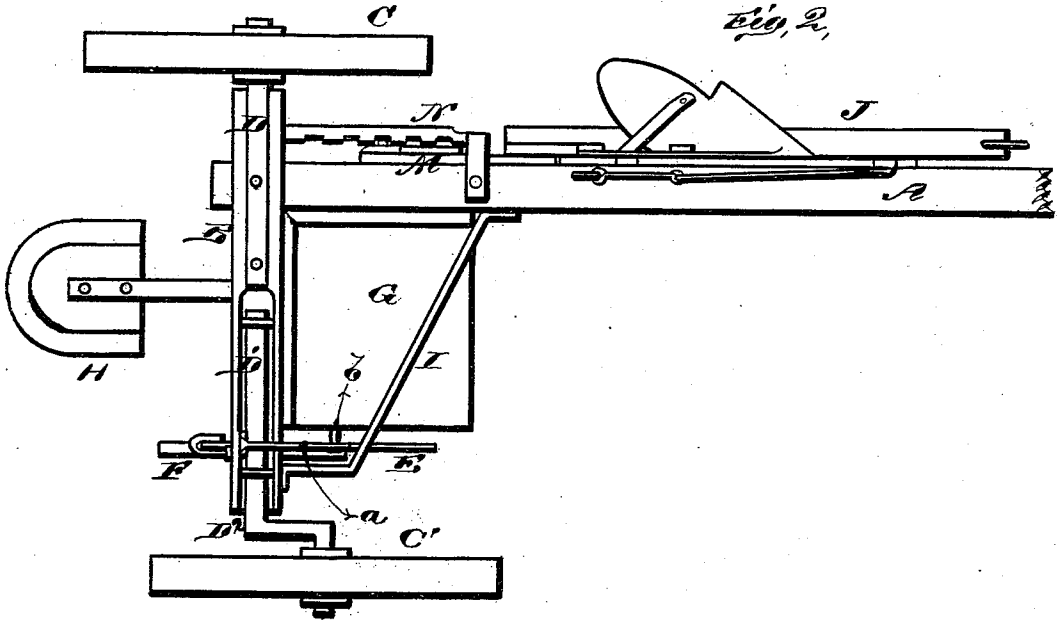
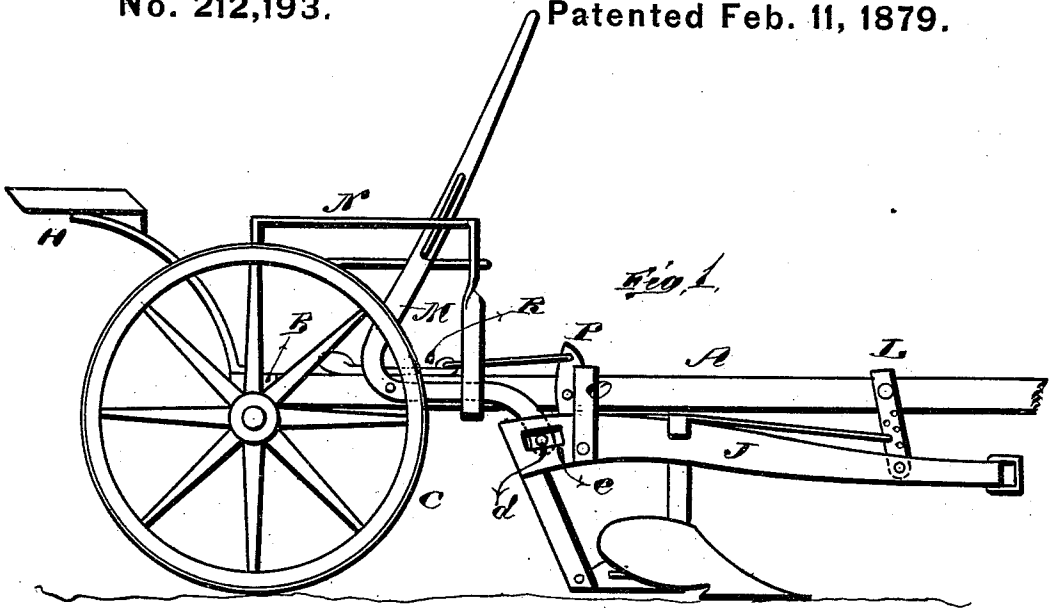

WITNESSES
H. Bates.

James J. Sheehy.

INVENTOR

Chester C. Clover
Gilmore Smith & Co.
ATTORNEYS

C. C. CLOVER.
Sulky-Plow.

No. 212,193.

Patented Feb. 11, 1879.

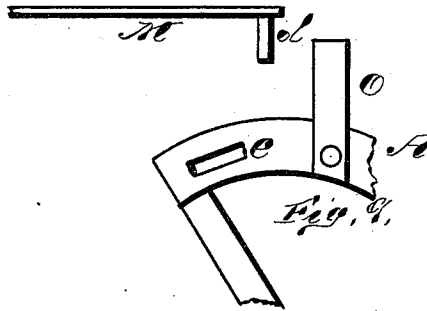
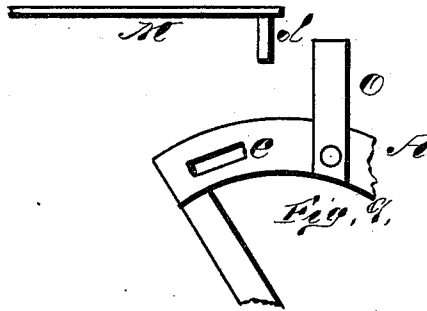
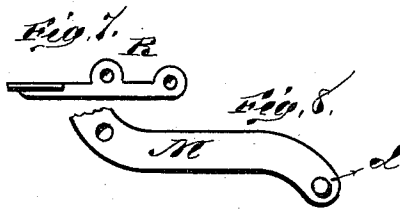
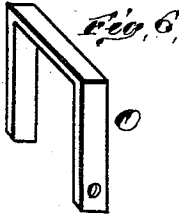
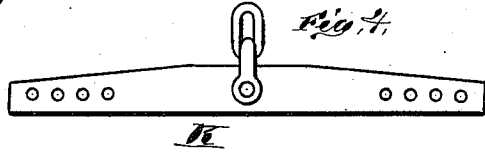
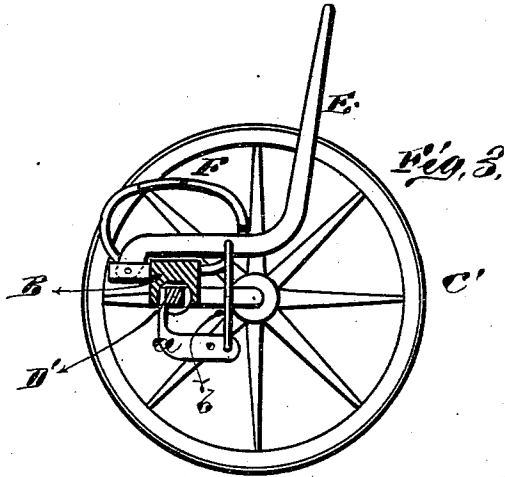

WITNESSES
E. H. Bates,
James J. Shreeve.

INVENTOR
Charles C. Clover
Gilman Smith & Co.
 ATTORNEYS

UNITED STATES PATENT OFFICE.

CHESTER C. CLOVER, OF OSWEGO, KANSAS.

IMPROVEMENT IN SULKY-PLOWS.

Specification forming part of Letters Patent No. **212,193**, dated February 11, 1879; application filed March 16, 1878.

To all whom it may concern:

Be it known that I, CHESTER C. CLOVER, of Oswego, in the county of Labette and State of Kansas, have invented a new and valuable Improvement in Sulky-Plows; and I do hereby declare that the following is a full, clear, and exact description of the construction and operation of the same, reference being had to the annexed drawings, making a part of this specification, and to the letters and figures of reference marked thereon.

Figure 1 of the drawings is a representation of a side view of my sulky-plow. Fig. 2 is a plan view. Figs. 3, 4, 5, 6, 7, 8, and 9 are detail views thereof.

The nature of my invention consists in the construction and arrangement of a sulky attachment for plows, as will be hereinafter more fully set forth.

The annexed drawings, to which reference is made, fully illustrate my invention.

The frame consists simply of two pieces of wood, the tongue A and axle-tree B, firmly united together and supported upon wheels C C', of suitable dimensions. These wheels revolve, respectively, upon wrought-iron spindles D D', placed in grooves on the under side of the axle-tree A.

The spindle D is rigidly secured in the axle-tree, while the spindle D' is made to turn in bearings, and the outer end thereof crank-shaped, as at D², so that the wheel C' can be raised and lowered, as desired. This spindle D' is provided with an arm, a, connected, by a rod, b, with a lever, E, which is pivoted at the back of the axle, and held at any point desired in a rack, F.

To the tongue and axle is secured a platform, G, which supports a spring-seat, H. I is a brace connecting the tongue and axle, as shown.

J represents the plow-beam, provided at its forward end with a double-tree, K, the ends of which are perforated, so that the single-trees can be shifted out and in for lateral adjustment, so that the plow can be set to or from land without changing the line of draft

by shifting the single-trees to or from the center.

From the tongue A, at a suitable point, depends a rigid perforated bar, L, to which the plow-beam is connected by a bolt, and can be adjusted up and down to assist in regulating the depth of the plow.

To the rear portion of the tongue A, on the outer side, is pivoted an elbow-lever, M, from the forward end of which projects a pin, d, into a slot, e, in the rear end of the plow-beam. This gives the plow an inclined motion in lifting, freeing it from any obstruction without backing the team.

The lever M is held in a rack, N, in any of the known and usual ways.

To the plow-beam J is attached an iron holder, O, which passes over the tongue, and when the plow is down said holder is held by a dog, P, connected to a foot-lever, R, on the platform, by means of which the plow is held in the ground firmly and uniformly, while permitting it to be readily raised above the surface.

In this sulky attachment the draft is diminished by the plow being suspended on the attachment in front of the wheels and driver. All weight is therefore taken from the ground, thereby decreasing all friction except the usual cutting.

What I claim as new, and desire to secure by Letters Patent, is—

The plow-beam J, suspended near its front end by means of the perforated bar L, and suspended at its rear end by the holder O, in combination with an elbow-lever, M, the forward end of which works in a slot, e, in the rear end of the plow-beam, and the locking-dog P and foot-lever R, substantially as shown and described.

In testimony that I claim the above I have hereunto subscribed my name in the presence of two witnesses.

CHESTER C. CLOVER.

Witnesses:

F. A. BETTÉS,
W. M. SOMMERS.