

T. NAGEL.  
LAMP.

APPLICATION FILED OCT. 14, 1915.

1,270,858.

Patented July 2, 1918.

2 SHEETS—SHEET 1.

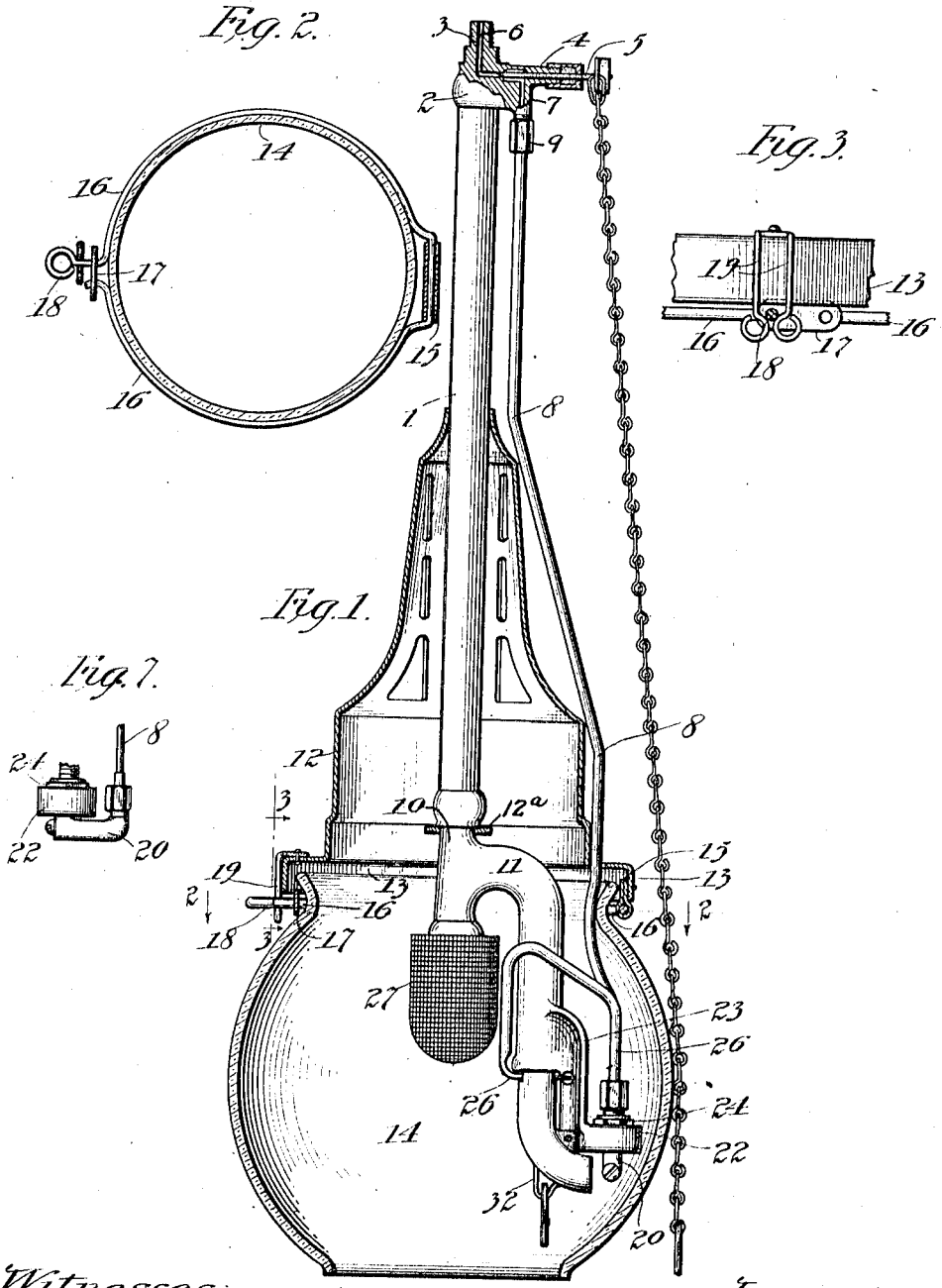

Witnesses:  
*W. F. Smith*  
*Flourence Mitchell*

Inventor:  
*Theodore Nagel*  
by *Frank D. Thomson*  
*Atty.*

T. NAGEL.  
LAMP.

APPLICATION FILED OCT. 14, 1915.

1,270,858.

Patented July 2, 1918.  
2 SHEETS—SHEET 2.

*Fig. 4.*

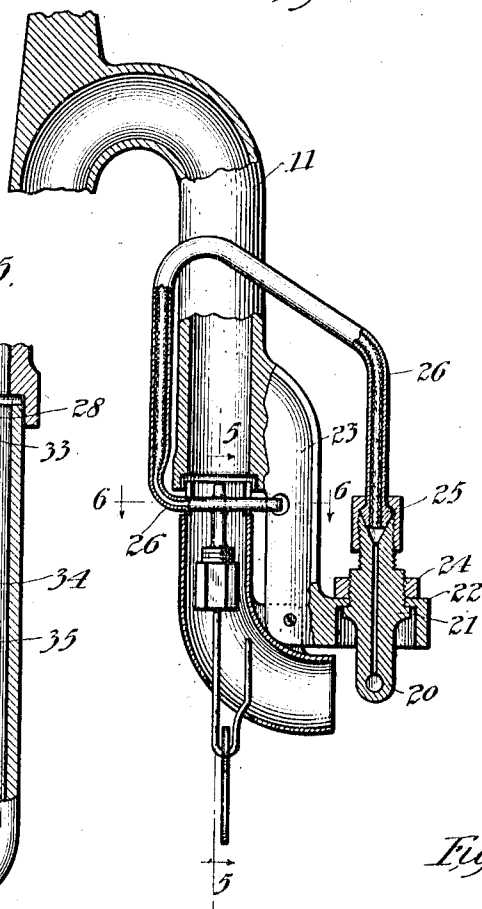

*Fig. 5.*

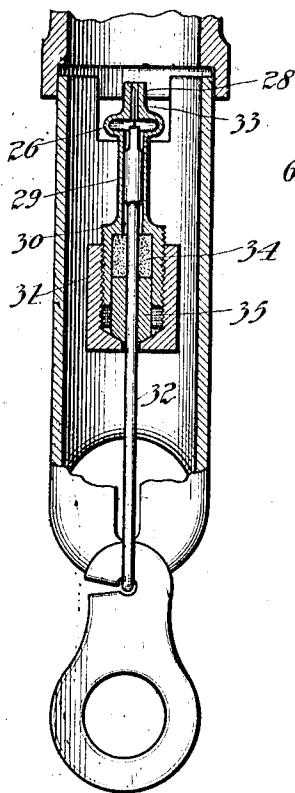

*Fig. 6.*

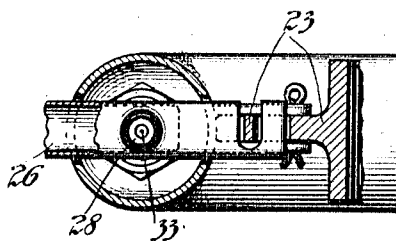

*Witnesses:*  
*W. F. Smith*  
*Florence Mitchell*

*Inventor:*  
*Theodore Nagel.*  
*by Frank D. Thayer*  
*Atty.*

# UNITED STATES PATENT OFFICE.

THEODORE NAGEL, OF CHICAGO, ILLINOIS.

LAMP.

1,270,858.

Specification of Letters Patent.

Patented July 2, 1918.

Application filed October 14, 1915. Serial No. 55,782.

*To all whom it may concern:*

Be it known that I, THEODORE NAGEL, a citizen of the United States, residing at Chicago, in the county of Cook and State of Illinois, have invented new and useful Improvements in Lamps, of which the following is a full, clear, and exact description.

My invention relates to hydro-carbon gas burners, and more particularly to burners for illuminating lamps in which oil is supplied to the burner under pressure.

The objects of my invention are, first to construct a lamp of this type with a minimum number of detachable or removable parts in as simple and inexpensive manner as possible; second, to provide a hydro-carbon gas lamp with an efficient removable vaporizer that is capable of rapidly generating the gas that is expelled into the mixing-chamber through a tip made integral therewith; third, to so construct and protect the jet that it will be kept free from drafts, and the discharge orifice thereof kept clean and free from accumulation of carbon, and, fourth, to so construct the lamp and the casing above it that said lamp can be inclosed within a spherical globe. These and other objects I accomplish by the means and in the manner hereinafter fully described, and as particularly pointed out in the claims, reference being had to the accompanying drawings forming a part hereof, in which—

Figure 1 is a side elevation of my improved burner showing the casing and globe thereof in section.

Fig. 2 is a transverse section of the globe and casing taken on dotted line 2—2, Fig. 1.

Fig. 3 is a side view of a fragment thereof illustrating the means for retaining the globe in its closed position surrounding the burner, drawn to actual scale.

Fig. 4 is a vertical section of a broken away portion of the mixing-chamber, the jet and the means for supplying oil thereto, drawn to the actual scale.

Fig. 5 is a vertical section of the jet taken on dotted line 5—5, Fig. 4, and the lower broken away end of the mixing-chamber, drawn to a larger scale.

Fig. 6 is a horizontal section taken on dotted line 6—6, Fig. 4.

Fig. 7 is a detail view of the coupling connecting the feed-pipe and vaporizer.

Referring to the drawings, 1 represents a tubular hanger the upper end of which is suitably screwed into a suitably shaped cou-

pling-head 2 whose upper end is screw-threaded and adapted to be tapped into the service-pipe (not shown) through which the illuminating or hydro-carbon fluid is fed from a suitable source, under pressure. This coupling-head 2 is provided with a suitable axial opening 3 which extends down through its upper screw-threaded end into the body thereof a short distance and then extends laterally in alinement with the bore of a laterally projecting stub 4. The bore of stub 4 is engaged by a screw-threaded needle-valve 5 whose outer end has a cross-bar secured thereto the ends of which have chains depending therefrom to enable the operator to rock the needle-valve one way or the other. The lateral portion of the passage nearest stub 4 being made greater in diameter to provide a chamber into which oil or illuminating fluid can enter when the spindle of valve 5 is turned in one direction and into which it is prevented from flowing when said spindle is turned in the opposite direction. The coupling-head 2 is also provided with a vertical passage 6 that extends down from said chamber through a depending stub 7, the lower screw-threaded end of which latter is engaged by the upper end of a wire feed-pipe 8 and is held in gas-tight relation thereto by means of a gland-nut 9.

The lower end of hanger 1 is screwed over the upper end of a solid stud 10 projecting upward in axial alinement with the shorter arm of an inverted substantially U-shaped tubular mixing-chamber 11, and the lower end of this hanger 1 is surrounded and inclosed by a suitable sheet-metal casing 12, the upper end portion of which is substantially cone-shaped and its truncated upper end connected in any suitable manner to the tubular hanger. The lower end of this casing is retained in a concentric position to said hanger by a transaxial bar 12<sup>a</sup> through an opening in the center of the length of which the lower end of said hanger passes. The lower end of casing 12 is flanged outward circumferentially and then downward to form a rim 13 which surrounds the upwardly flanged edges of the top opening of a globe 14. One side of this rim 13 has a hinge-plate 15 secured to the inner surface thereof in any suitable manner and the lower edge of this plate below the edge of the rim is formed into a knuckle in which a straight stretch of a wire band 16 is journaled. This wire band 16 surrounds the circumferential

channel resulting from flanging the upper edge of the upper opening of the globe, and diametrically opposite said hinge-plate 15 its ends are bent outwardly and secured together by a clip 17. One of the ends extends outwardly farther than the other and has its extremity bent into an eye to form a stud 18. When the globe is closed up into the rim of the casing this stud snaps between the lower looped ends of a U-shaped spring clasp 19 the upper bend of which latter is lapped over the lower flanged edge of the casing and secured thereto by riveting or otherwise.

Feed-pipe 8 extends down through a suitable opening in rim 13 of casing 12 into the globe and has its lower end secured in the mouth of the bore of one of the vertical members of the U-shaped coupling 20 by means of a suitable gland-nut. The opposite vertical member of this U-shaped coupling is provided with a circumferential flange 21, and above this flange it is screw-threaded and passed through an opening in the lower horizontal arm 22 of an L-shaped bracket 23 whose upper end is, preferably, cast in one piece with the lower end of the longer arm of the inverted U-shaped mixing-chamber 11. This arm 22 is hollowed out underneath, and the adjacent vertical member of coupling 20 passes up into this hollowed out portion, and immediately above said arm the screw-threaded vertical member has a nut 24 screwed thereon to clamp it to arm 22. Above the screw-threaded portion upon which this nut is screwed the vertical member of the coupling is still further reduced in diameter and screw-threaded. The bore of the coupling from the end thereof to which feed-pipe 8 is attached, to the base of the opposite vertical member, is, preferably, the same in diameter, but the bore of this last mentioned vertical member is considerably reduced in diameter and the upper end is made funnel-shaped and engaged by the cone-shaped head 25 of a vaporizer 26.

This vaporizer consists of a wire pipe that extends vertically upward from the coupling a short distance and is then bent laterally in an inclined direction toward the mixing-chamber 11. Approximately in the same horizontal plane with the top of the burner or mantle 27, that is secured to the end of the shorter arm of the mixing-chamber, this vaporizer-pipe 26 is bent partly around the intake or shorter arm of the mixing-chamber, and then it extends downwardly slightly below the end of the longer member of the mixing-chamber, and is then bent horizontally and transaxially across the mouth or intake end of said longer arm. The portion of the vaporizer-pipe passing under the longer arm of the mixing-chamber is flattened and at a point in alignment with the axis of said longer arm it is pro-

vided with an upwardly projecting jet 28, the bore of which is of comparatively small diameter and discharges upward into the longer arm of the mixing-chamber. The vaporizer-pipe has a tubular member 29 depending from the flattened lower portion thereof in alinement with the axis of jet 28, and the lower end 30 of this tubular member 29 is increased in diameter and exteriorly screw-threaded and engaged by a gland-nut 31.

A vertical rod 32 extends axially up through this member 29, and its upper portion within the reduced upper portion of said member is increased in diameter, and at its upper extremity it is provided with an axially extending needle 33, that enters and is adapted to have vertical play in the orifice of jet 28. The bore of the lower larger portion of tubular member 29 is likewise increased and packing 34 is placed within the same which is engaged by a sleeve 35 surrounding rod 32 and compressed by tightening gland-nut 31. This rod extends down a suitable distance below the gland-nut and is shaped so as to afford a finger grasp to enable it to be reciprocated so that needle 33 can clean out and set free any accumulation of carbon in the orifice of the jet.

The lower end of the longer branch of the inverted U-shaped mixing-chamber has a removable tubular extension 37 depending therefrom, which is, preferably, made of sheet metal bent so that its side edges form a longitudinal seam which is next bracket 23. The lower end of extension 37 is bent sidewise under the horizontal arm of the bracket a short distance, and at the inner curve of this bend the edges of the longitudinal seam thereof are provided with lips 38 that lap against and embrace a longitudinal fin 39 of bracket 23 between them and are secured thereto by a transverse pin 40 or its equivalent. The outer curve of the bent lower end of extension 37 is provided with a longitudinal slot 41 to permit of the passage of the lower portion of rod 32, and the upper edges of the extension are recessed at points diametrically opposite each other for the passage of the lower flattened portion of the vaporizer-pipe, which latter is extended therethrough and its extremity closed and provided with a lateral finger 42 that enters and is caught in a hole 43 in fin 39 of bracket 23. Extension 37 is for the purpose of preventing either transverse or vertical drafts of air affecting the jet, and thus effecting the steady discharge of gas therefrom, and an even steady glow of the mantle during the operation of the lamp.

In operation, valve 5 is manipulated to permit the oil to pass into and through pipe 8 and then through coupling 20 into vaporizer-pipe 26. The oil is forced through filtering material 44 in this vaporizing-pipe to

the jet and the application of a lighted match to the mantle vaporizes the oil in said vaporizer-pipe and simultaneously ignites said vapors as they pass through the mantle and causes the latter to become incandescent, in which condition said mantle radiates heat and continues to vaporize the oil in the vaporizer-pipe so long as the oil flows there-through. Should carbon form in the orifice of the jet and obstruct the discharge of gas therefrom it can be dislodged and pushed out simply by reciprocating rod 32.

What I claim as new is:

1. In a hydro-carbon lamp comprising a mixing-chamber, a burner, a feed pipe leading to the mixing-chamber, a vaporizer extending transversely across the mixing-chamber, an aperture in the vaporizer, a rod arranged to enter the aperture; said rod extending from the transverse portion of the vaporizer, and a tubular extension having a lateral projection; said extension surrounding said rod and having an end constructed to engage the mixing-chamber above the transverse portion of the vaporizer, and said rod having a construction which permits of its being reciprocated within the tubular projection.

2. In a hydro-carbon lamp comprising a mixing-chamber, a burner, a feed pipe leading to the mixing-chamber, a vaporizer extending transversely across the mixing-chamber, an aperture in the vaporizer, a rod arranged to enter the aperture; said rod extending from the transverse portion of said vaporizer, and a tubular extension constructed to engage the mixing-chamber above the portion of said vaporizer which extends transversely across the mixing-chamber.

3. In a hydro-carbon lamp comprising a

mixing-chamber, a burner, a feed pipe leading to the mixing-chamber, a vaporizer connected to the feed pipe, a tubular extension leading from the mixing-chamber, the end of said tubular extension remote from the mixing-chamber being bent laterally, a rod extending from the vaporizer through an aperture in the laterally extending portion of the tubular extension.

4. In a hydro-carbon gas lamp comprising a mixing-chamber, a burner, a feed pipe leading to the mixing-chamber, a vaporizer connected to the feed pipe and extending transversely across the mixing-chamber, a tubular extension leading from the mixing-chamber and having the end adjacent the mixing-chamber recessed to permit said end to be passed beyond the vaporizer, and means for holding said tubular extension in position.

5. In a hydro-carbon gas lamp comprising a mixing-chamber, a burner, a feed pipe leading to the mixing-chamber, a vaporizer connected to the feed pipe and extending transversely across the mixing-chamber, a tubular extension leading from the mixing-chamber, the end of said mixing-chamber being recessed to receive the upper end of the tubular extension, and the end of said extension adjacent the mixing-chamber being recessed to permit said end to be passed beyond the transverse portion of the vaporizer, and means for holding said extension with relation to the mixing-chamber.

In witness whereof I have hereunto set my hand this 8th day of October, 1915.

THEODORE NAGEL.

Witnesses:

ANTHONY G. RADOMSKI,  
FRANK D. THOMASON.