

[72] Inventors **Richard W. Woodcock**
Nashville, Tenn.;
John P. Yackel, Circle Pines, Minn.
 [21] Appl. No. **857,726**
 [22] Filed **Sept. 15, 1969**
 [45] Patented **Nov. 16, 1971**
 [73] Assignee **American Guidance Service, Inc.**
Circle Pines, Minn.

2,258,282 10/1941 Ericson 281/33
 2,516,809 7/1950 Soderberg 281/33
 2,523,202 9/1950 Ericson 281/33

FOREIGN PATENTS

177,947 4/1922 Great Britain 402/74
 434,360 8/1935 Great Britain 402/74

Primary Examiner—Jerome Schnall
Attorney—Burd, Braddock & Bartz

[54] **DISPLAY DEVICE**
2 Claims, 10 Drawing Figs.

[52] U.S. Cl. **281/33,**
 281/16
 [51] Int. Cl. **B42d 3/16**
 [50] Field of Search **281/33, 31;**
 40/102, 104.2, 104.18; 402/73, 74

[56] **References Cited**
UNITED STATES PATENTS

2,865,659 12/1958 Zimmerman 281/31
 2,091,260 8/1937 Farkas et al. 40/104.18

ABSTRACT: A presentation folder for the display of test or other educational material or sales or promotion material, or the like. The device is a compact unit for storing and displaying pictorial and/or typographical material printed or otherwise reproduced on pages within the device. When closed, it is in the form of a book. When opened, it assumes the form of an easel presenting stimulus material. The unit includes relatively stiff front and back covers hinged to a spine and includes a plurality of pages of pictorial and/or typographical stimulus material loosely bound, as by spiral or other wire binding, or the like, for flipping from one side to the other of the easel formed when the device is opened.

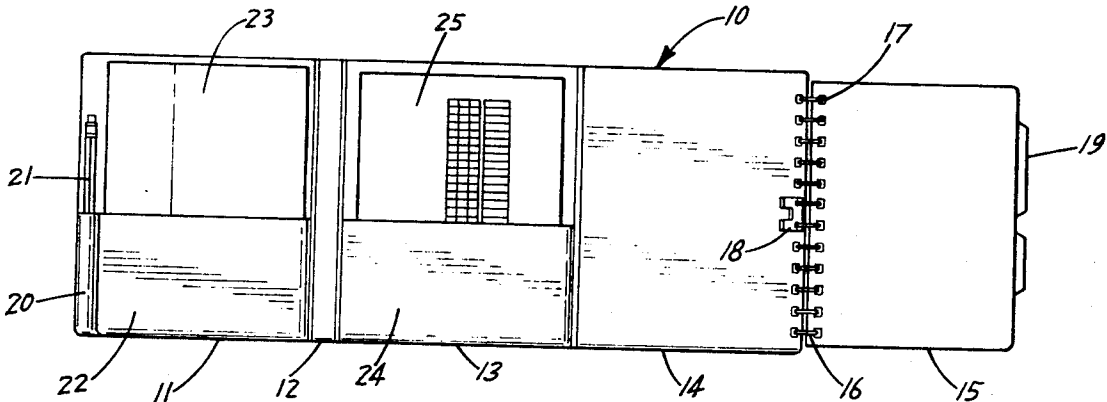

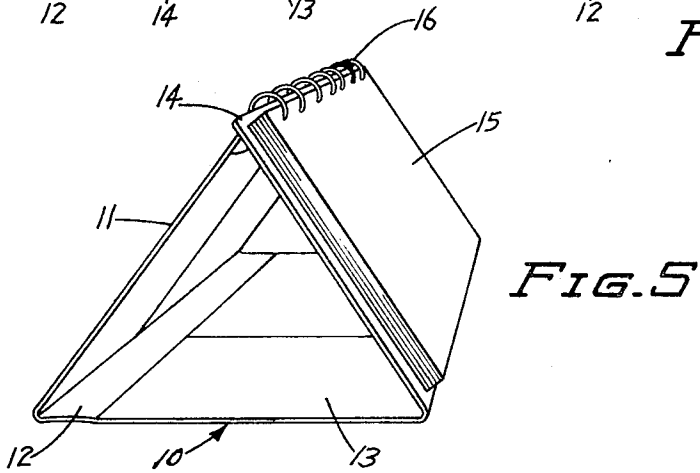
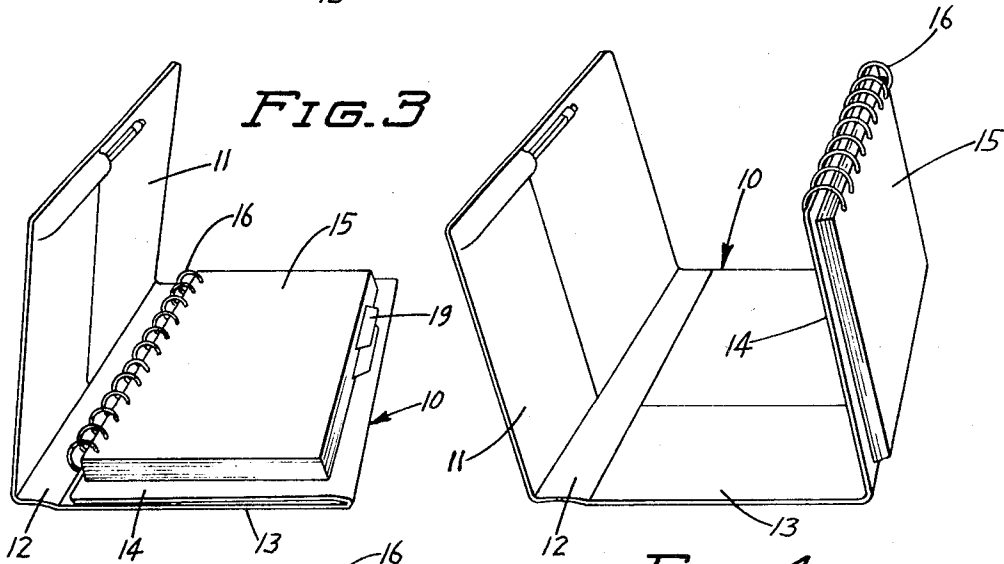
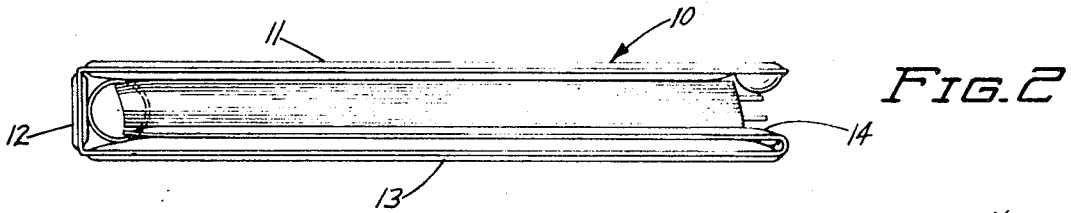
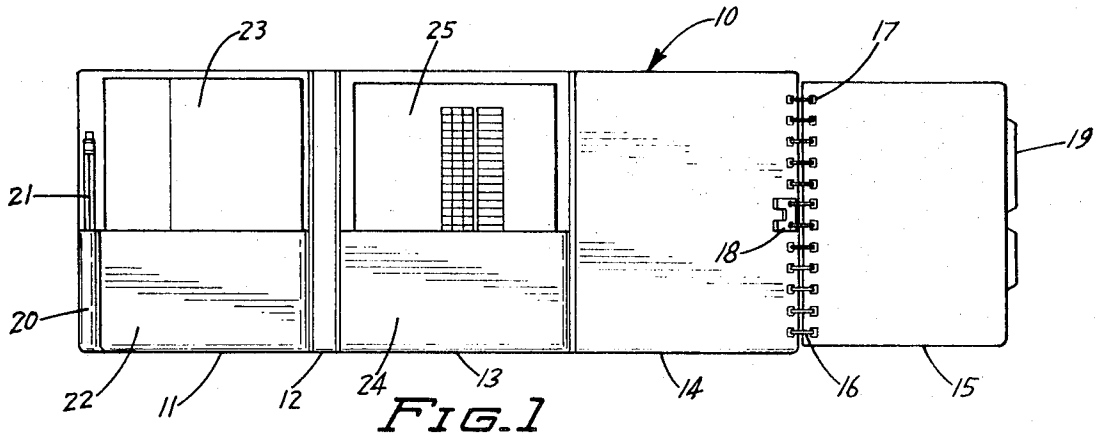

INVENTORS
RICHARD W. WOODCOCK
JOHN P. YACKEL
BY *Burd, Braddock & Barty*

ATTORNEYS

DISPLAY DEVICE

This invention relates to a compact presentation folder for the display of test or other educational material or sales or promotion material, or the like. When closed, it resembles a book or notebook. When opened, it assumes the form of an easel on which is displayed pictorial or typographical stimulus material loosely bound so that material on consecutive pages can be serially displayed by flipping the pages from the front to the back sides of the easel. Although intended primarily for educational use, for testing and similar purposes, it is useful for various sale and promotional purposes, for presentation of insurance and investment data, and the like.

The invention is illustrated in the accompanying drawings in which:

FIG. 1 is a top plan view of one form of the display device shown laid out flat and fully open;

FIG. 2 is an end elevation on an enlarged scale showing the same form of device fully closed;

FIG. 3 is a perspective view showing the device partially open;

FIG. 4 shows the device in an intermediate position preparatory to forming an easel structure,

FIG. 5 is a perspective view of the device assembled in easel form for display of the stimulus material;

FIG. 6 is a fragmentary plan view showing in greater detail the form of a latch or clip member for maintaining the easel stable; and

FIG. 7 is an end elevation of the structure of FIG. 6 shown partly in section along the line 7-7 and in the direction of the arrows.

Referring now to the drawings, and particularly to FIGS. 1 through 5, the display device according to one form of the present invention comprises a booklike unit, indicated generally at 10. The unit includes generally a flat rectangular rigid panel 11 corresponding to the front cover of a book, a similar panel 12 of the same height but lesser width corresponding to the spine of a book, and a panel 13 generally similar to panel 11 corresponding to the back cover of a book. Panels 11 and 13 are hingedly connected to the narrower spine panel 12 as is common in books and notebooks.

A further auxiliary back cover panel 14 corresponding generally to panels 11 and 13 is hingedly secured to the edge of panel 13 opposite from spine 12. Panel 14 is foldable so that it may be folded into face-to-face contact with the inside surface of panel 13, as seen in FIGS. 2 and 3, panels 13 and 14 then together forming a compound back cover. A stack of a plurality of pages 15 of material to be displayed is loosely bound to the free edge of panel 14 opposite from its hinged connection with panel 13, as by means of wire binding or ring binding 16, or the like. The pages 15 are desirably slightly smaller in their overall dimensions than panel 14 so as to permit the edges of the panels to provide a slightly overhanging and protective lip for the pages when the device is in folded book form, as in FIG. 2.

The adjacent edges of panel 14 and pages 15 are provided with a plurality of perforations 17 to accommodate the loose wire or ring binding. A latch or clip member 18 is secured to the inside surface of panel 14, as by being secured by the binding 16, for the purpose of holding the device in assembled easel form, as explained in greater detail hereinafter.

The sheets 15 may be imprinted on one or both sides. For test purposes, the one side visible to the examinee will bear certain stimulus material and the opposite side of the next adjacent sheet which is simultaneously visible to the examiner bears related identifying or explanatory material. Where several sets of stimulus material may be included in a single device, suitable indexing means 19 may be provided.

If desired, the inside surfaces of front and rear covers 11 and 13 may be provided with pockets, such as a pocket 20 for receiving a pencil 21, a pocket 22 for receiving an instruction manual 23, a pocket 24 for receiving a stack of scoring sheets 25, and the like. The spine panel 12 is of sufficient width to accommodate the combined thickness of the plurality of sheets

15, panel 14 and the material contained within the pockets 22 and 24 so that the closed unit lies generally flat, as seen in FIG. 2.

The device is assembled to form an easel generally as follows:

The closed unit, as in FIG. 2, is placed on a desk or table with panel 13 in engagement with the surface. The front cover panel 11 is lifted, as in FIGS. 3 and 4, sufficient to permit panel 14 with its attached stack of pages 15 to be lifted free, as in FIG. 4. Then the front cover 11 is folded inwardly toward panel 14 and the edge lip of panel 11 is caused to engage latch or clip 18 on the inside surface of panel 14. This is best seen in FIG. 6 and 7.

The latch 18 comprises a thin flat plate 26 having at least two perforations 27 through which the loose binding 16 (in this instance shown as spiral wire binding) may pass. The plate has a plurality of projecting spaced-apart tabs 28 and 29 which together define a channel into which the lip of front cover panel 11 is received. This insures stability of the easel structure such that accidental pressure against the top surface of panel 11 will not cause the easel to collapse. Although it provides a less stable assembled easel structure, the latch means may alternatively be a simple tab extending along the edge of panel 14 adjacent the binding 16 generally in engagement with the surface of panel 14 and extending toward its connection with panel 13. The edge of panel 11 can engage this tab by slipping under it. The latch means is not essential to the easel structure, but may be eliminated altogether at the cost of a slight loss in stability.

In assembled position, as shown in FIG. 5, the unit is now ready for use. The easel is positioned with the surface of pages 15 facing the person or the group to which the material is to be displayed. Then, one by one, after the material on the front face of each page 15 has been displayed for the requisite time, that page is flipped over on the relatively loose binding 16 so as to lie against the angularly disposed front cover panel 11. The pages are turned in sequence until all of the desired display material has been exhibited.

The unit is closed by flipping the plurality of pages 15 back against panel 14, lifting panel 14 to release the latch 18, lifting front cover panel 11 slightly to permit panel 14 to resume its face-to-face engagement with back cover panel 13 and then closing front cover panel 11. When used for testing purposes, the easel shields from the examinee the scoring sheet on which the examiner records responses. In this manner, distraction of the examinee by the recording of responses is effectively eliminated.

When in assembled form for use as a display easel, the device resembles a triangular prism whose ends are generally isosceles triangles. One cover is the base of the prism. The loose wire or ring binding is at one edge, most generally at the apex. The two angularly disposed sides are formed by the other cover and the stack of pages to be displayed.

It is apparent that many modifications and variations of this invention as hereinbefore set forth may be made without departing from the spirit and scope thereof.

The embodiments of the invention in which an exclusive property or privilege is claimed are defined as follows:

1. A compact booklike storage and display device comprising:

- a. a front cover and a back cover each hingedly connected to opposite sides of relatively narrower spine, said covers and spine being generally flat and rigid;
- b. one of said covers is a compound cover composed of two generally flat and rigid panels;
- c. the first of said panels is hingedly connected to the spine and to the other panel;
- d. at least one stack of a plurality of pages bearing the material to be displayed;
- e. said stack of pages being loosely bound to the free edge of said other panel opposite from its hinged connection to the first panel, said loose binding lying generally along a line parallel to the spine, being loose enough to permit the

3

4

pages to be folded against either side of said other panel, and comprising a plurality of perforations along one side edge of said stack of pages and the adjacent side edge of said other panel to which the pages are bound;

- f. at least one generally annular fastening element extending through contiguous perforations of said pages and panel; 5
- g. positive latching means provided adjacent the edge of said other panel on the surface abutable against the first panel and adjacent to said loose binding, said latching means comprising: 10
 - 1. a plate engaging the surface of said other panel;
 - 2. a plurality of tabs projecting from said plate;
- 3. said tabs being spaced apart and defining a longitudinal channel parallel to the edge of said other panel adjacent to the loose binding, 15
- 4. the free edge of said other cover being engageable by said channel;

5. the plate of said latching means being provided with at least two perforations in registry with perforations in said other panel; and

6. said annular fastening element extending through said perforations in said plate;

h. said device when closed forming a generally flat booklike storage unit; and

i. said device when folded into a generally triangular prism, having one of said covers as a base, said loose binding as one edge, the other of said covers as one side and the stack of pages as the other side, forming an easel display for the material on said pages.

2. A device according to claim 1 further characterized in that the inside surfaces of at least one of said covers is provided with at least one pocket for receiving material relevant to the use of the material on said stack of pages.

* * * * *

20

25

30

35

40

45

50

55

60

65

70

75

UNITED STATES PATENT OFFICE
CERTIFICATE OF CORRECTION

Patent No. 3,620,552 Dated November 16, 1971

Inventor(s) Richard W. Woodcock and John P. Yackel

It is certified that error appears in the above-identified patent and that said Letters Patent are hereby corrected as shown below:

Figures 8, 9 and 10 should be deleted.

Signed and sealed this 7th day of March 1972.

(SEAL)
Attest:

EDWARD M. FLETCHER, JR.
Attesting Officer

ROBERT GOTTSCHALK
Commissioner of Patents