

H. B. Meech,  
Bleaching Paper.

No. 106,711.

Patented Aug. 23, 1870.

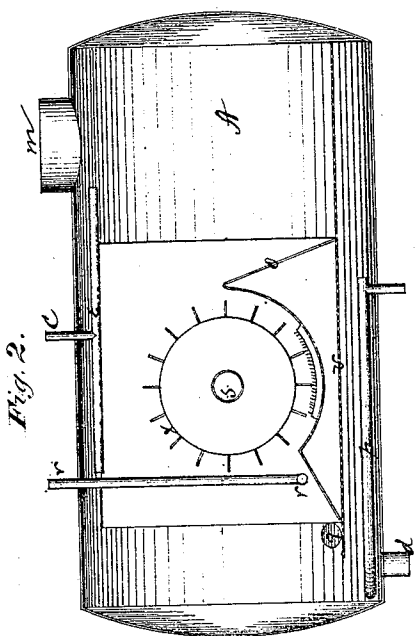

Fig. 2.

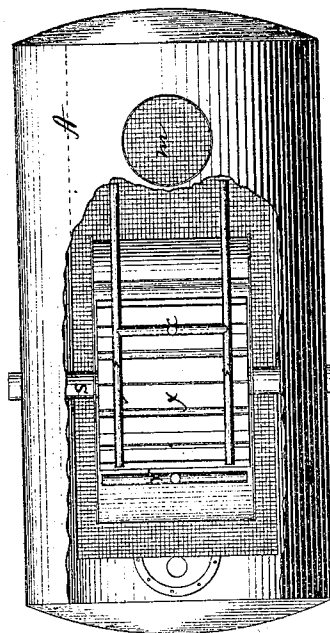

Fig. 3.

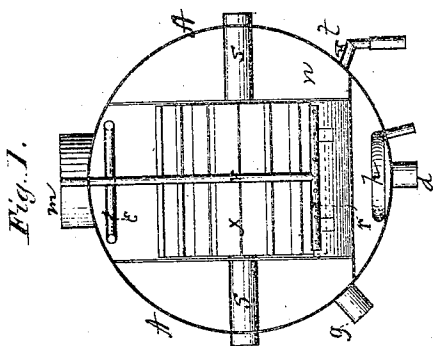

Fig. 1.

Witnesses:  
*J. Lehmann*  
*Chas. H. Fowler*

Inventor:  
*Harrison B. Meech*

*H. B. Meech,  
Bleaching Paper.*

*2 Sheets, Sheet 2.*

*No. 106,711.*

*Patented Aug. 23, 1870.*

*Fig. 1.*

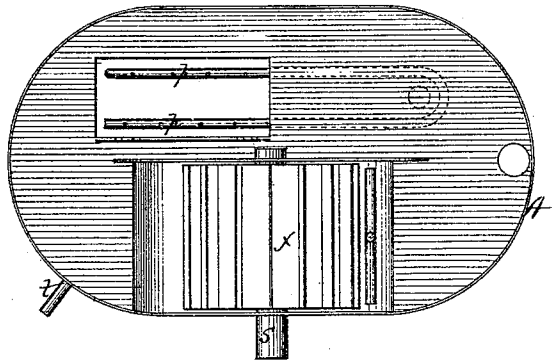

*Fig. 2.*

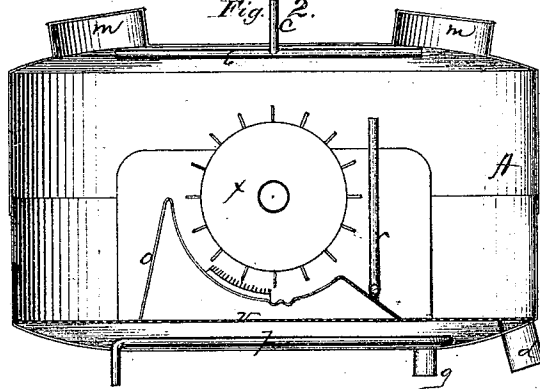

*Fig. 3.*

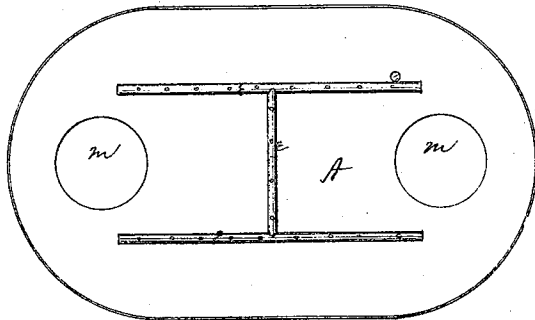

*Witnesses:*

*J. Lehmann  
Chas. W. Fowler*

*Inventor:*

*Harrison B. Meech*

# UNITED STATES PATENT OFFICE.

HARRISON B. MEECH, OF FORT EDWARD, NEW YORK.

## IMPROVEMENT IN REDUCING AND BLEACHING PAPER-STOCK.

Specification forming part of Letters Patent No. **106,711**, dated August 23, 1870.

*To all whom it may concern:*

Be it known that I, HARRISON B. MEECH, of Fort Edward, in the county of Washington and in the State of New York, have invented certain new and useful Improvements in Apparatus and Process for Reducing Straw, Wood, and other Fibrous Substances to a Pulp for Paper; and I do hereby declare the following to be a full, clear, and exact description thereof, reference being had to the accompanying drawing and to the letters of reference marked thereon.

The nature of my invention consists in the construction and application of an engine-boiler for the purpose of disintegrating and separating the fibers from each other, when boiling paper-stock for pulp, by a grinding and rubbing operation at the same time the heat and chemicals are acting upon the stock, with as small an amount of chemicals as possible, and that the chemicals may act upon all the fibers equally without destroying them; also, for the purpose of bleaching said fibers white by agitation and the use of chlorine liquor, steam, air, and gas, it being very essential that the stock should be thoroughly agitated while bleaching.

In order to enable others skilled in the art to which my invention appertains to make and use the same, I will now proceed to describe its construction and operation, referring to the annexed drawing, which forms a part of this specification, and in which—

Figure 1 is an end view, showing the inside of boiler. Fig. 2 is a longitudinal vertical section; and Fig. 3 is a plan view, a part of the boiler being broken away to show the wheel within the same.

A represents a steam-tight cylinder-boiler. *m* is the man-hole; *s*, the engine-shaft that turns the roller or wheel on the inside of the boiler. *x* is the wheel or roller within the cylinder A. *c* is the liquor and water pipe, through which the liquor or water is forced through the perforated pipe *e*, as shown in Fig. 2. *r* is the steam, air, and gas pipe, through which the steam is forced in at the mouth of the engine, and strikes all the stock, passes through under the engine wheel or roller *x*, and back around the sides between the space *n*, and so on around and through the engine-wheel until thoroughly ground. *v* is the perforated false

bottom, through which the liquor and wash water are drained off through the pipe *d*. *g* is the discharge stock-pipe. *p* is a perforated pipe between the perforated bottom and the boiler, to admit water and steam. *t* is a test-cock, for the purpose of testing a sample from time to time, to know when the stock is well reduced or bleached. *o* represents the back-fall and bed-plate.

For reducing paper-stock the straw or wood is cut into short lengths and packed in the boiler; then a solution of sulphur and lime-water is forced through pipes *e e* into the stock; then boiled for about three hours by admitting steam through pipe *r*, (at the same time the engine-wheel is run at about two hundred revolutions per minute;) then said liquor is drained off through pipe *d*. The stock may then be boiled again for about three hours by a pressure of steam of about fifty pounds to the square inch, in a weak solution of pure caustic soda of about one degree strength, Baumé, at the proportion of three quarts to one pound of straw.

For boiling wood use about three degrees' strength to six hours' time. This liquor is then drawn off and the stock washed by forcing water through pipe *e*, and, at the same time, letting the water drain off through pipe *d*. After washing the stock it is ready for bleaching.

For bleaching, the boiler should be about half-full of brown stock; then is added a solution of chlorine liquor of about one-half degree strength, Baumé, in sufficient quantity so that the stock will be moved readily by the engine-wheel *x*, and agitated for about fifteen minutes; then steam, air, and chlorine gas are admitted through pipe *r*, and the engine-wheel is revolved until the stock is thoroughly bleached, which can be ascertained by the test-cock *t*. Then the stock is ready to be made into paper.

A boiler with an engine-wheel on the inside, as described, may be used in combination with any known chemical process now in use. It is of a great advantage for grinding and boiling straw, &c.

Having thus fully described my invention, what I claim as new, and desire to secure by Letters Patent, is—

1. The engine wheel or roller *x* within a

boiler as a means of grinding and rubbing at the same time as boiling the fibers, for the purpose of reducing paper-stock, as described.

2. The within-described boiler A, provided with air and water pipes, and used in combination with the wheel or roller *x*, substantially as and for the purposes herein set forth.

3. The process herein described of bleaching paper-stock, the same consisting of the application within the boiler A of chlorine liquor, chlorine gas, steam, and air to the pulp, substantially as set forth.

4. The pipe *r* for the admission of a jet of steam at the mouth of the beating-engine at time of grinding, for the purpose of bleaching the fiber, as set forth.

In testimony that I claim the foregoing I have hereunto set my hand this 26th day of July, 1870.

HARRISON B. MEECH.

Witnesses:

F. LEHMANN,  
CHARLES H. FOWLER.