

C. M. SOWARD & J. A. DYKEMAN.

Pumps.

No. 133,955.

Patented Dec. 17, 1872.

Fig. 1.

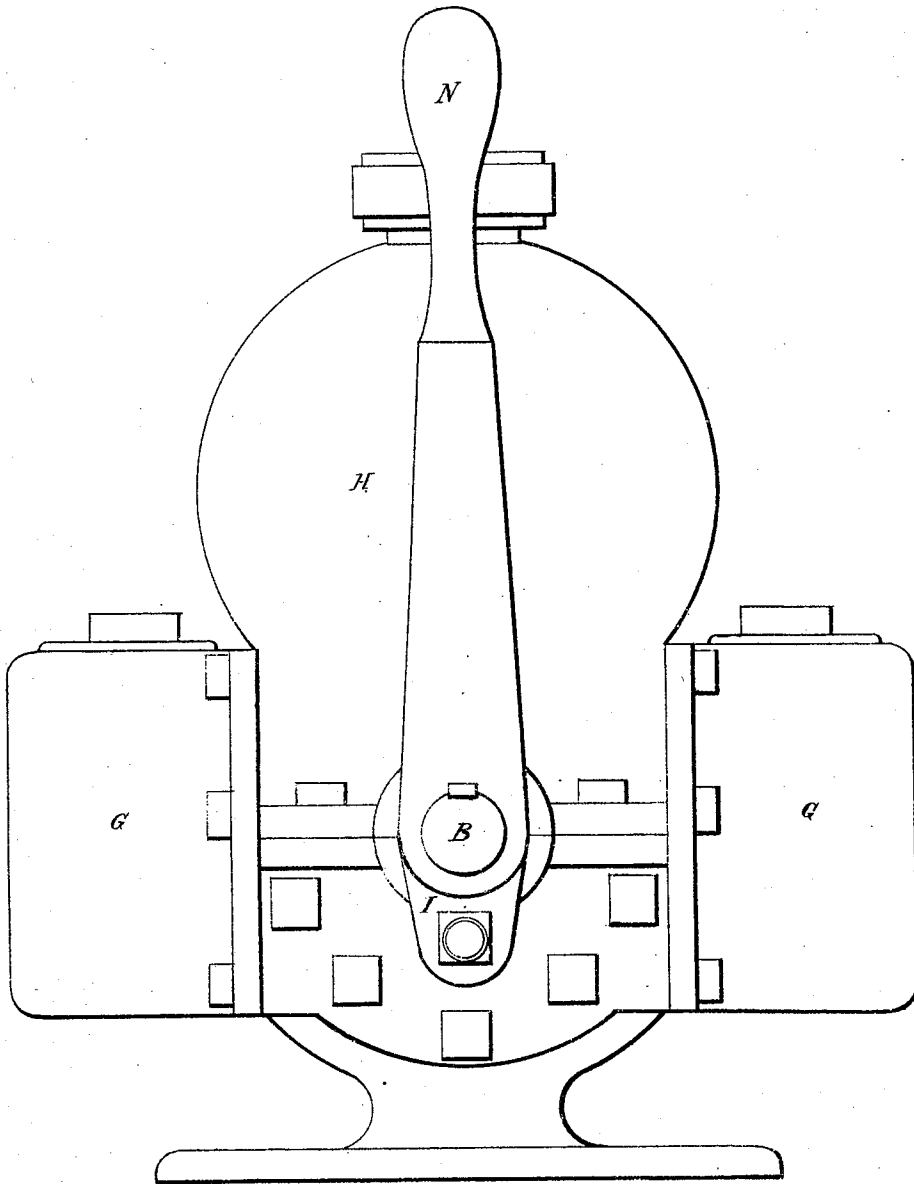

Witnesses:

Charles W. Ashford
R. C. Maloney

Inventors:

Charles M. Soward,
James A. Dykeman

C. M. SOWARD & J. A. DYKEMAN.

Pumps.

No. 133,955.

Patented Dec. 17, 1872.

Fig. 2.

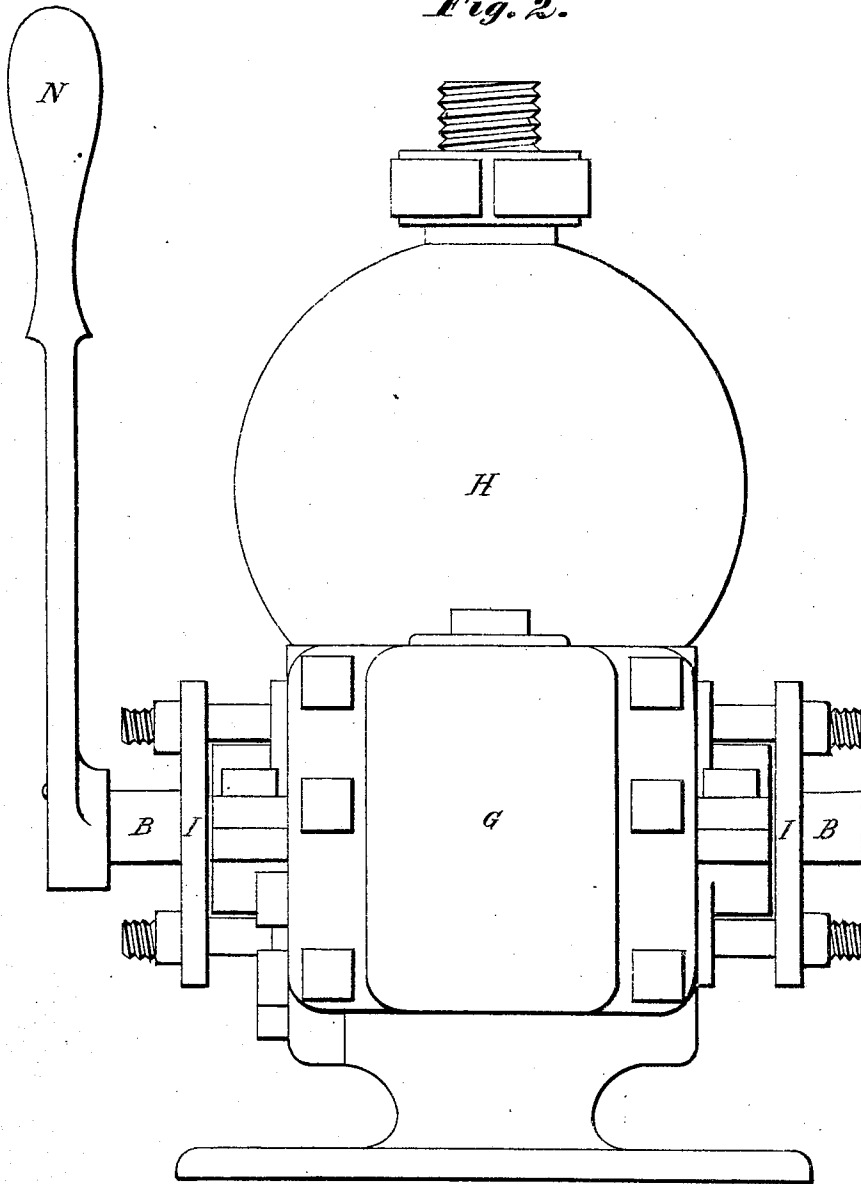

Witnesses:

Charles W. Ashford
R. C. Maloney Jr

Inventors:

Charles M. Soward
James A. Dykeman

C. M. SOWARD & J. A. DYKEMAN.

Pumps.

No. 133,955.

Patented Dec. 17, 1872.

Fig. 3.

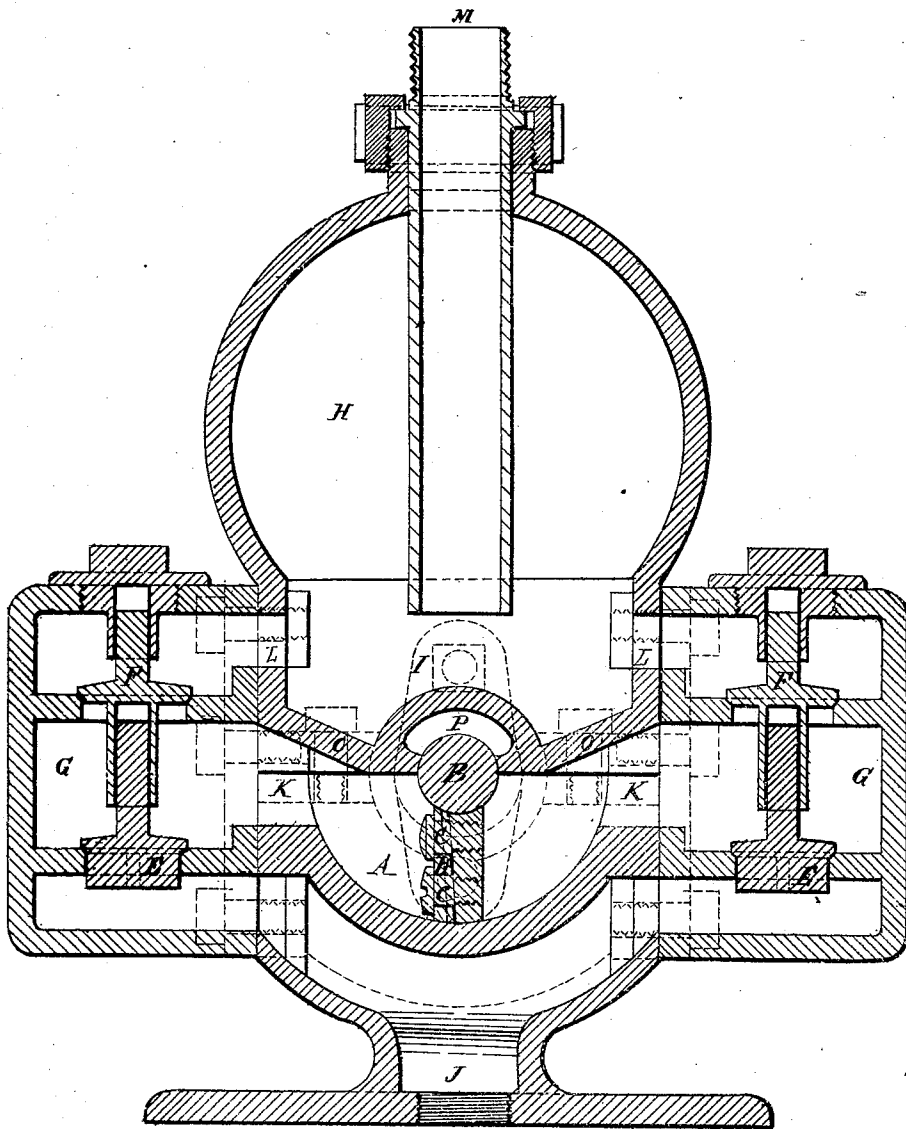

Witnesses

Charles W. Ashford
P. C. Malone

Inventors:

Charles M. Soward,
James A. Dykeman

C. M. SOWARD & J. A. DYKEMAN.

Pumps.

No. 133,955.

Patented Dec. 17, 1872.

Fig. 4.

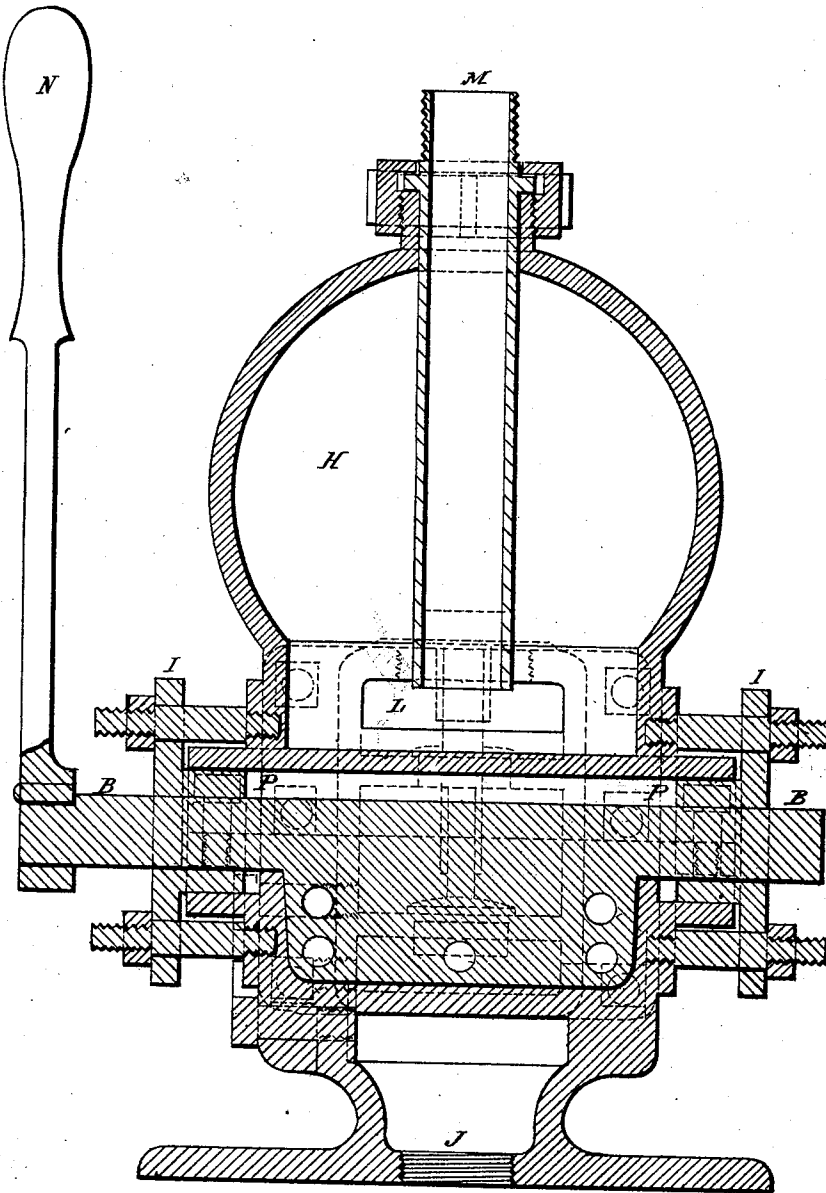

Witnesses:

Charles W Ashford
P. C. Maloney

Inventors:

Charles M Soward
James A Dykeman

C. M. SOWARD & J. A. DYKEMAN.

Pumps.

No. 133,955.

Patented Dec. 17, 1872.

Fig. 5.

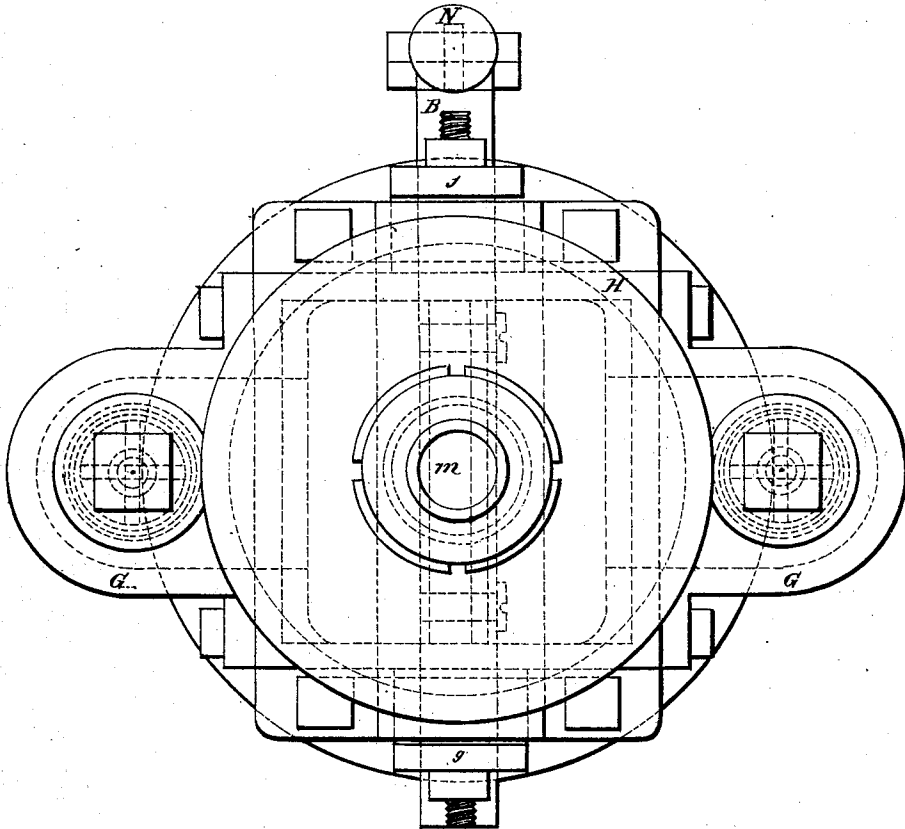

Witnesses:

Charles W. Ashford
R. C. Malone Jr.

Inventors:

Charles M. Soward
James A. Dykeman

UNITED STATES PATENT OFFICE.

CHARLES M. SOWARD AND JAMES A. DYKEMAN, OF DYER COUNTY, TENN.,
ASSIGNORS OF ONE-THIRD OF THEIR RIGHT TO GEO. W. SOWARD.

IMPROVEMENT IN PUMPS.

Specification forming part of Letters Patent No. 133,955, dated December 17, 1872.

To all whom it may concern:

Be it known that we, CHARLES M. SOWARD and JAMES A. DYKEMAN, both of the county of Dyer and State of Tennessee, have invented a new Return-Motion, Double-Acting, Half-Rotary, Lifting and Force Pump, to be applied in all places for which pumps are generally used; and we do hereby declare that the following is a full, clear, and exact description of the construction and operation of the same, reference being had to the annexed drawing making a part of this specification, in which—

Figure 1 is a side view. Fig. 2 is an end view. Fig. 3 is a section through center of side view. Fig. 4 is a section through center of end view. Fig. 5 is a top view, showing inside by dotted lines.

Letter A is a semi-cylinder. B is a shaft with wing attached. C is a clamp on wing; D, packing between wing and clamp; E and E, receiving-valves; F and F, discharging-valves; G G, valve-chambers; H, air-chamber. I and I are stuffing-box glands; J, receiving-pipe. K and K are openings. L and L are openings; M, discharge opening or pipe; N, the lever; O, division between semi-cylinder A and air-chamber H. P and P is packing over wing-shaft B and under division O, secured by glands I and I.

Operated by moving lever N attached to wing-shaft B, causing wing to sweep the semi-cylinder A from openings K to K; drawing the water through receiving-pipe J into cham-

ber G, and through valves E and through openings K into semi-cylinder A; and then alternately receiving through pipe J into chambers G and G, through valves E and E, and through openings K and K into semi-cylinder A, and back; discharging through openings K and K, and up through valves F and F, and through openings L and L into air-chamber H, and out through discharge-pipe M.

We make no claim to valves, pipes, air-chamber, or lever. We are aware that these are not new.

What we claim as our invention, and desire to secure by Letters Patent of the United States, is—

The semi-cylinder A, the wing-shaft B, the clamp C, and packing D, the division O, the receiving and discharge openings K and K, and the return half-rotary motion of wing-shaft B, causing wing to sweep semi-cylinder A from openings K to K, causing the water to flow into and out of semi-cylinder A, through openings K and K, and through valves F and F, and through openings L and L into air-chamber H, and out through discharge-pipe M, and packing as arranged over winged shaft B secured by glands I and I.

CHARLES M. SOWARD.
JAMES A. DYKEMAN.

Witnesses:

CHARLES W. ASHFORD,
R. C. MALON, Jr.