

(19)



(11)

EP 4 289 592 B1

(12)

EUROPEAN PATENT SPECIFICATION

(45) Date of publication and mention of the grant of the patent:

25.06.2025 Bulletin 2025/26

(51) International Patent Classification (IPC):

B29C 43/58 ^(2006.01) **H01M 50/105** ^(2021.01)
B29C 43/34 ^(2006.01) **B29C 43/04** ^(2006.01)
B29C 43/36 ^(2006.01) **G01B 11/22** ^(2006.01)

(21) Application number: **22904475.5**

(52) Cooperative Patent Classification (CPC):

B29C 43/58; B29C 43/22; H01M 10/04;
H01M 10/0404; H01M 50/105; B29C 2043/585;
 B29C 2793/0027; B29C 2793/009; B29L 2031/3468;
 G01B 11/22; Y02E 60/10

(22) Date of filing: **03.11.2022**

(86) International application number:

PCT/KR2022/017130

(87) International publication number:

WO 2023/106641 (15.06.2023 Gazette 2023/24)

(54) **EQUIPMENT AND METHOD FOR MOLDING POUCH**

FORMVORRICHTUNG UND FORMVERFAHREN FÜR BEUTEL

ÉQUIPEMENT DE FORMATION ET PROCÉDÉ DE FORMATION POUR POCHE

(84) Designated Contracting States:

**AL AT BE BG CH CY CZ DE DK EE ES FI FR GB
GR HR HU IE IS IT LI LT LU LV MC ME MK MT NL
NO PL PT RO RS SE SI SK SM TR**

(74) Representative: **Plasseraud IP**

**104 Rue de Richelieu
CS92104
75080 Paris Cedex 02 (FR)**

(30) Priority: **06.12.2021 KR 20210173290**

(56) References cited:

EP-A1- 4 044 306 WO-A1-2021/112481
CN-A- 112 110 188 JP-A- 2004 268 934
JP-A- 2009 170 134 KR-A- 20150 026 172
KR-A- 20150 026 172 KR-A- 20200 059 615
KR-B1- 101 397 926

(43) Date of publication of application:

13.12.2023 Bulletin 2023/50

(73) Proprietor: **LG ENERGY SOLUTION, LTD.**

Seoul 07335 (KR)

- **ANONYMOUS: "Importance of average | All About Circuits", 1 January 2018 (2018-01-01), XP093191291, Retrieved from the Internet <URL:https://forum.allaboutcircuits.com/threads/importance-of-average.144929/>**

(72) Inventors:

- **SEOK, Heon Gi**
Daejeon 34122 (KR)
- **KANG, Dae Hyung**
Daejeon 34122 (KR)

EP 4 289 592 B1

Note: Within nine months of the publication of the mention of the grant of the European patent in the European Patent Bulletin, any person may give notice to the European Patent Office of opposition to that patent, in accordance with the Implementing Regulations. Notice of opposition shall not be deemed to have been filed until the opposition fee has been paid. (Art. 99(1) European Patent Convention).

Description**TECHNICAL FIELD**

[0001] The present invention relates to equipment for molding a pouch, in which an accommodation part for accommodating an electrode assembly is molded in a pouch film, and a depth of the accommodation part molded in the pouch film is accurately measured and inspected, and a method for molding the pouch.

BACKGROUND ART

[0002] In general, secondary batteries refer to chargeable and dischargeable batteries, unlike primary batteries that is impossible to charge. Such secondary batteries are widely used in high-tech electronic devices such as phones, notebook computers, and camcorders.

[0003] In addition, the secondary batteries may be variously classified according to a structure of an electrode assembly. For example, the secondary batteries may be classified into a stack type structure, a jelly-roll-type structure, and a stack/folding type structure.

[0004] Such a secondary battery includes an electrode assembly and a case accommodating the electrode assembly, and the electrode assembly has a structure in which electrodes and separators are alternately stacked.

[0005] A method for manufacturing the pouch includes a supply process of continuously supplying a pouch film, a molding process of continuously molding an accommodation part for accommodating an electrode assembly in the supplied pouch film, and a cutting process of cutting a portion between the accommodation parts, which are molded in the pouch film, to manufacture a finished product pouch.

[0006] Here, the method for manufacturing the pouch further includes an inspection process of measuring a depth of the accommodation part molded in the pouch film to inspect whether defects occur when the cutting process is completed, and in the inspection process, an worker inspects the depth of the accommodation part molded in the pouch film by using a ruler or a vernier caliper.

[0007] However, the inspection process has a problem in that a lot of work time is required. Particularly, it is difficult to obtain accurate inspection results due to measurement errors for each worker, and since the inspection has to be performed after the molding process is completed, there is a problem in that continuity of a work is poor.

[0008] In the background art document KR 2015 0026172 A discloses a process and apparatus for measuring depth of a pouch for secondary battery using ultrasound and document WO2021/112481 A1 discloses a method for manufacturing an electrode assembly and a manufacturing device capable of increasing the degree of stacking alignment by measuring the position of basic units comprising photographing the electrode assembly

to measure width distances of electrodes.

DISCLOSURE OF THE INVENTION**TECHNICAL PROBLEM**

[0009] In equipment and method for molding a pouch of the present invention for solving the above problems, an inspection process of inspecting a depth of an accommodation part molded in a pouch film may be performed between a process of molding the pouch film and a process of cutting the pouch film, and the inspection process may accurately measure and inspect the depth of the accommodation part molded in the pouch film by using a displacement sensor to significantly reduce a work time and improve continuity of a work. In addition, an object of the present invention is to improve inspection accuracy because all the accommodation parts molded in the pouch film are capable of being inspected.

TECHNICAL SOLUTION

[0010] Equipment for molding a pouch according to the present invention for achieving the above objects includes: a transfer device configured to transfer a pouch film; a molding device configured to press a top surface of the pouch film transferred by the transfer device so as to mold an accommodation part for accommodating an electrode assembly; and an inspection device configured to calculate a depth value of the accommodation part formed in the pouch film and compare the calculated depth value with a set input value so as to inspect whether defects occur, wherein the inspection device includes: a distance measuring member provided at a reference point set above the pouch film to measure each of a first measurement value that is a distance from the reference point to the pouch film connected to an upper end of the accommodation part and a second measurement value that is a distance from the reference point to a bottom surface of the accommodation part; and an inspection member configured to calculate a depth value of the accommodation part by subtracting the first measurement value from the second measurement value measured by the distance measuring member, wherein if the calculated depth value is within a set input value, it is determined as normal, and if the calculated depth value is out of the set input value, it is determined as defective, wherein The inspection device further includes a full-width adjusting member configured to allow the distance measuring member to move in a full-width direction of the pouch film, which is perpendicular to a transfer direction of the pouch film, so as to adjust a position of the distance measuring member and includes a height adjusting member configured to allow the full-width adjusting member to move toward the pouch film so as to adjust a height of the distance measuring member with respect to the pouch film.

[0011] The distance measuring member is provided as

a displacement sensor.

[0012] The distance measuring member may measure the distance from the reference point to the pouch film connected to an upper end of the accommodation part several times within a set range to calculate the first measurement value as an average of the measured distance values.

[0013] The distance measuring member may measure the distance from the reference point to the bottom surface of the accommodation part several times within a set range to calculate the second measurement value as an average of the measured distance values.

[0014] The set range may be set to 1 mm to 5 mm.

[0015] A method for molding a pouch according to the present invention includes: a transfer process of transferring a pouch film; a molding process of pressing a top surface of the transferred pouch film to mold an accommodation part for accommodating an electrode assembly; and an inspection process of calculating a depth value of the accommodation part formed in the pouch film and comparing the calculated depth value with a set input value to inspect whether defects occur, wherein the inspection process includes: a measuring process of measuring each of a first measurement value that is a distance from a reference point to the pouch film connected to an upper end of the accommodation part and a second measurement value that is a distance from the reference point to a bottom surface of the accommodation part by using a distance measuring member provided above the pouch film; and an inspecting process of calculating a depth value of the accommodation part by subtracting the first measurement value from the second measurement value measured in the measuring process, wherein if the calculated depth value is within a set input value, it is determined as normal, and if the calculated depth value is out of the set input value, it is determined as defective, wherein the measuring process further includes a process of allowing the distance measuring member to move in a full-width direction of the pouch film, which is perpendicular to a transfer direction of the pouch film, so as to adjust a position of the distance measuring member and further includes a process of allowing the full-width adjusting member to move toward the pouch film so as to adjust a height of the distance measuring member with respect to the pouch film.

[0016] In the measuring process, the distance measuring member is provided as a displacement sensor.

[0017] In the measuring process, the distance from the reference point to the pouch film connected to an upper end of the accommodation part may be measured several times within a set range to calculate the first measurement value as an average of the measured distance values.

[0018] In the measuring process, the distance from the reference point to the bottom surface of the accommodation part may be measured several times within a set range to calculate the second measurement value as an average of the measured distance values.

[0019] The set range may be set to 1 mm to 5 mm.

[0020] The method may further include, after the inspection process is completed, a cutting process of cutting a portion between the accommodation parts formed in the pouch film to manufacture the pouch; and a removing process of discharging and removing the pouch, in which the accommodation part determined as defective in the inspection process, among the pouches is formed.

ADVANTAGEOUS EFFECTS

[0021] The molding equipment of the present invention may include the displacement sensor to accurately measure and inspect the depth of the accommodation part molded in the pouch film, thereby significantly reducing the work time and improving the continuity of the work. Particularly, the molding equipment of the present invention may inspect all the accommodation parts molded in the pouch film to obtain the accurate inspection results.

BRIEF DESCRIPTION OF THE DRAWINGS

[0022]

FIG. 1 is a perspective view illustrating a pouch according to the present invention.

FIG. 2 is a schematic process view illustrating equipment for molding the pouch according to the present invention.

FIG. 3 is a perspective view illustrating a slit cutting device of the equipment for molding the pouch according to the present invention.

FIG. 4 is a perspective view illustrating a molding device of the equipment for molding the pouch according to the present invention.

FIG. 5 is a perspective view illustrating a distance measuring member of the equipment for molding the pouch according to the present invention.

FIG. 6 is a view illustrating a distance measurement state of the distance measuring member.

FIG. 7 is a side view illustrating a full-width adjusting member of the equipment for molding the pouch according to the present invention.

FIG. 8 is a side view illustrating a height adjusting member of the equipment for molding the pouch according to the present invention.

FIG. 9 is a perspective view illustrating a main cutting device of the equipment for molding the pouch according to the present invention.

FIG. 10 is a flowchart illustrating a method for molding a pouch according to the present invention.

MODE FOR CARRYING OUT THE INVENTION

[0023] Hereinafter, embodiments of the present invention will be described in detail with reference to the accompanying drawings in such a manner that the tech-

nical idea of the present invention may easily be carried out by a person with ordinary skill in the art to which the invention pertains. The present invention may, however, be embodied in different forms and should not be construed as limited to the embodiments set forth herein. In the drawings, anything unnecessary for describing the present invention will be omitted for clarity, and also like reference numerals in the drawings denote like elements.

[Pouch of present invention]

[0024] As illustrated in FIG. 1, a pouch 10 of the present invention is configured to accommodate an electrode assembly (not shown). That is, the pouch 10 includes an accommodation part 11 accommodating the electrode assembly and a sealing part 12 sealing the accommodation part 11.

[0025] The pouch 10 may be manufactured by molding a pouch film 20. That is, when the accommodation part 11 provided with a pair of accommodation grooves for accommodating the electrode assembly may be molded in a top surface of the pouch film 20, and when the pouch film 20 is folded in half so that the pair of accommodation grooves correspond to each other, the pouch 10 capable of accommodating the electrode assembly may be manufactured.

[0026] The pouch 10 having such a structure may be manufactured through the equipment for molding the pouch according to the present invention. Particularly, the equipment for molding the pouch according to the present invention may accurately inspect whether the accommodation part 11 formed in the pouch film 20 is defective in the process of manufacturing the pouch. Thus, a work time may be significantly shortened, and continuity of the work may be improved, and thus, all the accommodation parts 11 formed in the pouch film 20 may be inspected to obtain accurate inspection results.

[Equipment for molding pouch according to the present invention]

[0027] For example, as illustrated in FIG. 2, equipment for molding a pouch according to the present invention includes a transfer device 100, a slit cutting device 200, a molding device 300, an inspection device 400, a main cutting device 500, and a removing device 600.

Transfer device

[0028] As illustrated in FIG. 2, the transfer device 100 is configured to transfer a pouch film 20 having a long sheet shape up to the main cutting device 500 via the slit cutting device 200, the molding device 300, and the inspection device 400. That is, the transfer device 100 may be provided as a conveyor belt, on which the pouch film 20 is disposed on a top surface thereof, and which transfers the pouch film 20 up to the slit cutting device 200.

Slit cutting device

[0029] As illustrated in FIG. 3, the slit cutting device 200 is configured to cut a portion between the accommodation parts to be formed to improve efficiency and cutting performance when the pouch film is cut. That is, the slit cutting device 200 includes a rotating blade 210 that cuts a portion of the pouch film 20 in a full-width direction when viewed in FIG. 4.

Molding device

[0030] As illustrated in FIG. 4, the molding device 300 is configured to press the top surface of the transferred pouch film 20 so as to form an accommodation part for accommodating the electrode assembly. That is, the molding device 300 includes a die 310, on which the pouch film 20 is disposed, and a punch provided above the die 310 to press the top surface of the pouch film 20 so as to mold the electrode assembly accommodation part 11.

[0031] In the pouch film 20 in which the accommodation part 11 is formed by the molding device 300, a depth of the accommodation part 11 may be changed due to restoring force, and the accommodation part 11 formed in the pouch film 20 may need to be inspected in whether a change in depth of the accommodation part 11 formed in the pouch film 20 occurs. Here, the inspection device 400 is used.

Inspection device

[0032] As illustrated in FIGS. 5 and 6, the inspection device 400 is configured to inspect the depth of the accommodation part 11 formed in the pouch film 20 to determine whether defects occur. That is, the inspection device 400 calculates a depth value of the accommodation part 11 formed in the pouch film 20 and compares the calculated depth value with an set input value to inspect whether the defects occur.

[0033] For example, the inspection device 400 includes a distance measuring member 410 and an inspection member 420.

[0034] The distance measuring member 410 is provided at a reference point O set above the pouch film 20 to measure a first measurement value α that is a distance from the reference point to the pouch film 20 connected to an upper end of the accommodation part 11 and a second measurement value β that is a distance from the reference O to a bottom surface of the accommodation part 11.

[0035] The inspection member 420 calculates a depth value γ of the accommodation part 11 by subtracting the first measurement value α from the second measurement value β measured by the distance measuring member 410, and then if the calculated depth value is within the set input value range, it is determined as normal, and if it is out of the range, it is determined as defective.

[0036] The formula for calculating the depth value (γ) is

$(\beta) - (\alpha) = (\gamma)$.

[0037] The depth value γ of the accommodation part 11 and the set input value may vary depending on a size and thickness of the electrode assembly to be accommodated in the pouch film 20.

[0038] The distance measuring member 410 is provided as a displacement sensor, and the first measurement value α and the second measurement value β may be accurately measured through the displacement sensor. The displacement sensor is a sensor used to measure a linear distance or a linear position moved by an object, and includes a laser displacement sensor.

[0039] The distance measuring member 410 measures the linear distance from the reference point to the pouch film 20 connected to the upper end of the accommodation part 11, e.g., measures the linear distance several times within a set range A partitioned in the pouch film 20 to calculate a first measure value as an average of the measured distance values. For example, the distance measuring member 410 may measure the linear distance from the reference point to the set range A partitioned in the pouch film 20 four or more times to calculate a first measurement value as an average of remaining values excluding maximum and minimum values among the measured distance values.

[0040] The distance measuring member 410 measures the linear distance from the reference point to the bottom surface of the accommodation part 11, e.g., measures the linear distance several time within the set range partitioned on the bottom surface of the accommodation part 11 to calculate a second measurement value as an average of the measured distance values. For example, the distance measuring member 410 may measure the linear distance from the reference point to the bottom surface of the accommodation part 11 of the pouch film 20 four or more times to calculate a second measurement value as an average of remaining values excluding maximum and minimum values among the measured distance values.

[0041] The set range A may be set to 1 mm to 5 mm, preferably set to 2 mm to 3 mm. Here, if the set range A is 1 mm or less, a distance value of the same position may be measured, and if the set range A is 5 mm or more, moving force of the distance measuring member 410 is greatly required, resulting in poor equipment performance.

[0042] Therefore, the inspection device 400 may accurately inspect the depth of the accommodation part 11 formed in the pouch film 20 during the molding process of the pouch film 20 to determine whether defects occur, thereby improving efficiency continuity of the work.

[0043] As illustrated in FIG. 7, the inspection device 400 includes a full-width adjusting member 430 that allows the distance measuring member 410 to move in a full-width direction (left and right direction of the pouch film 20 when viewed in FIG. 5) of the pouch film 20, which is perpendicular to a transfer direction of the pouch film 20 so as to adjust a position of the distance measuring

member 410.

[0044] That is, the full-width adjusting member 430 is configured to adjust the position of the distance measuring member 410 in the full-width direction of the pouch film 20. The full-width adjusting member 430 may be provided as a guide rod provided in the full-width direction of the pouch film 20 and movably coupled to the distance measuring member 410. That is, when the distance measuring member 410 move in a longitudinal direction of the guide rod, the position of the distance measuring member 410 may be adjusted while moving in the full-width direction of the pouch film 20.

[0045] As illustrated in FIG. 8, the inspection device 400 further includes a height adjusting member 440 that allows the full-width adjusting member 430 to move to the pouch film 20 so as to adjust a height of the distance measuring member 410 fixed to the full-width adjusting member 430 with respect to the pouch film 20. That is, the height adjusting member 440 may be provided as a cylinder that allows the full-width adjusting member 430 to descend toward the pouch film 20. Thus, the distance measuring member 410 may be accurately aligned with the set reference point, and as a result, the accurate first and second measurement values may be obtained.

Main cutting device

[0046] As illustrated in FIG. 9, the main cutting device 500 cuts a portion between the accommodation parts 11 of the pouch film 20 passing through the inspection device 400 to manufacture a pouch. Here, the cutting device may cut the pouch film 20 in the full-width direction based on a cutting surface that is cut on the pouch film 20 by the slit cutting device 200 to improve cutting accuracy.

[0047] The equipment for molding the pouch according to the present invention may further include a removing device, which removes the pouch having the accommodation part 11 determined as defective by the inspection device 400 among the pouches cut by the main cutting device 500, in a process line.

Removing device

[0048] When the pouch having the accommodation part 11 determined as defective by the inspection device 400 is cut, the removing device 600 may absorb and remove the pouch having the defective accommodation part 11 in the process line. Thus, it is possible to prevent defective pouch from being transferred to the process line for manufacturing a secondary battery.

[0049] Therefore, the equipment for molding the pouch according to the present invention may inspect whether the accommodation part 11 formed in the pouch film 20 is defective in the process of manufacturing the pouch, thereby reducing the work time and improving the continuity of the work.

[0050] Hereinafter, a method for molding a pouch using

equipment for molding the pouch according to the present invention will be described.

[Method for molding pouch according to the present invention]

[0051] As illustrated in FIG. 10, the method for molding the pouch according to the present invention may include a transfer process, a slit cutting process, a molding process, an inspection process, a main cutting process, and a removing process.

[0052] In the transfer process, referring to FIG. 2, a pouch film 20 in the form of a long sheet is transferred to the molding process using a conveyor belt, which is a transfer device 100.

[0053] Referring to FIG. 3, in the slit cutting process, a portion of the space between accommodation parts to be formed in the pouch is cut using the slit cutting device 200.

[0054] In the molding process, a top surface of the pouch film 20 is pressed by a molding device 300 to form the accommodation part 11 for accommodating an electrode assembly. Here, the molding device 300 continuously molds the accommodation part 11 at regular intervals on the top surface of the pouch film 20 being transferred. That is, when the pouch film 20 is disposed on the die 310, the molding device 300 presses the top surface of the pouch film 20 while the punch 320 descends to mold the accommodation part 11 for accommodating the electrode assembly.

[0055] In the inspection process, a depth value of the accommodation part 11 formed in the pouch film 20 is calculated, and the calculated depth value is compared with a set input value to inspect whether defects occur. That is, the inspection process includes a measuring process and an inspecting process. Here, an inspection device 400 provided with a distance measuring member 410 and an inspection member 420 is used.

[0056] In the measuring process, a first distance value that is a linear distance at a right angle from a reference point to the pouch film 20 connected to an upper end of the accommodation part 11 and a second distance value that is a linear distance at a right angle from the reference point to a bottom surface of the accommodation part 11 are measured using the distance measuring member 410 provided above the pouch film 20.

[0057] Here, in the measuring process, the distance from the reference point to the pouch film 20 connected to the upper end of the accommodation part 11 may be measured several times within a set range A using the distance measuring member 410 to calculate a first measurement value as an average of the measured distance values.

[0058] In addition, in the measuring process, the distance from the reference point to a bottom surface of the accommodation part 11 may be measured several times within the set range A using the distance measuring member 410 to calculate a second measurement value as an average of the measured distance values.

[0059] The set range A may be set to 1 mm to 5 mm.

[0060] The measuring process may further include a process of allowing the distance measuring member 410 to move in a full-width direction of the pouch film 20, which is perpendicular to a transfer direction of the pouch film 20, so as to adjust a position of the distance measuring member 410. Thus, measurement accuracy may be improved by adjusting the position of the distance measuring member 410 in the full-width direction of the pouch. In addition, in the measuring process, the distance measuring member 410 may descend toward the pouch film 20 to adjust a height of the distance measuring member 410 with respect to the pouch film 20. Thus, the height of the distance measuring member 410 may be adjusted to match the reference point.

[0061] In the inspecting process, a depth value of the accommodation part 11 is calculated by subtracting the first measurement value from the second measurement value measured in the measuring process using the inspection member 420, and then if the calculated depth value is within the set input value range, it is determined as normal, and if it is out of the range, it is determined as defective.

[0062] The distance measuring member 410 is provided as a displacement sensor, and thus, the first and second measurement values may be accurately measured.

[0063] In the main cutting process, the pouch film 20 between the accommodation parts 11, in which the inspecting process is performed, is cut using the main cutting device 500 to manufacture the pouch 10. Here, the pouch film 20 is cut based on a cutting portion of the pouch film 20, which is formed in the slit cutting process.

[0064] In the removing process, the pouch having the accommodation portion 11 determined to be defective among the pouches cut by the main cutting process may be adsorbed using the removing device 600 and then removed in a process line. Thus, it is possible to prevent the defective pouches from being transferred to an assembly line for assembling a secondary battery.

[0065] Accordingly, the scope of the present invention is defined by the appended claims more than the foregoing description and the exemplary embodiments described therein. Various modifications within the claims are to be regarded to be in the scope of the present invention.

[Description of the Symbols]

[0066]

10: Pouch
 20: Pouch film
 11: Accommodation part
 12: Sealing part
 100: Transfer device
 200: Slit cutting device
 210: Rotating blade

300:	Molding device	
310:	Die	
320:	Punch	
400:	Inspection device	
410:	Distance measuring member	5
420:	Inspection member	
430:	Full-width adjusting member	
440:	Height adjusting member	
500:	Main cutting device	
600:	Removing device	10

Claims

1. Equipment for molding a pouch (10), comprising:

a transfer device (100) configured to transfer a pouch film (20);

a molding device (300) configured to press a top surface of the pouch film (20) transferred by the transfer device so as to mold an accommodation part (11) for accommodating an electrode assembly; and

an inspection device (400) configured to calculate a depth value of the accommodation part (11) formed in the pouch film (20) and compare the calculated depth value with a set input value so as to inspect whether defects occur, wherein the inspection device (400) comprises:

a distance measuring member (410) provided at a reference point (O) set above the pouch film to measure each of a first measurement value (α) that is a distance from the reference point to the pouch film (20) connected to an upper end of the accommodation part (11) and a second measurement value (β) that is a distance from the reference point to a bottom surface of the accommodation part (11); and

an inspection member (420) configured to calculate a depth value (γ) of the accommodation part (11) by subtracting the first measurement value from the second measurement value measured by the distance measuring member (410), wherein if the calculated depth value (γ) is within a set input value, it is determined as normal, and if the calculated depth value (γ) is out of the set input value, it is determined as defective, **characterized in that** the distance measuring member (410) is provided as a displacement sensor, wherein the inspection device (400) further comprises a full-width adjusting member (430) configured to allow the distance measuring member to move in a full-width direction of the pouch film (20), which is perpendicular to a transfer direction of the pouch film, so as to adjust a position of

the distance measuring member and wherein the inspection device further comprises a height adjusting member (440) configured to allow the full-width adjusting member (430) to move toward the pouch film so as to adjust a height of the distance measuring member with respect to the pouch film.

2. The equipment of claim 1, wherein the distance measuring member (410) measures the distance from the reference point to the pouch film connected to an upper end of the accommodation part (11) several times within a set range to calculate the first measurement value as an average of the measured distance values.

3. The equipment of claim 1, wherein the distance measuring member (410) measures the distance from the reference point to the bottom surface of the accommodation part (11) several times within a set range to calculate the second measurement value as an average of the measured distance values.

4. The equipment of claim 2 or 3, wherein the set range is set to 1 mm to 5 mm.

5. A method for molding a pouch (10), the method comprising:

a transfer process of transferring a pouch film (20);

a molding process of pressing a top surface of the transferred pouch film to mold an accommodation part (11) for accommodating an electrode assembly; and

an inspection process of calculating a depth value (γ) of the accommodation part (1) formed in the pouch film and comparing the calculated depth value with a set input value to inspect whether defects occur, wherein the inspection process comprises:

a measuring process of measuring each of a first measurement value (α) that is a distance from a reference point (O) to the pouch film connected to an upper end of the accommodation part and a second measurement value (β) that is a distance from the reference point to a bottom surface of the accommodation part (11) by using a distance measuring member (410) provided above the pouch film; and
an inspecting process of calculating a depth value (γ) of the accommodation part by subtracting the first measurement value from the second measurement value mea-

5
 10
 15
 20
 25
 30
 35
 40
 45
 50

sured in the measuring process, wherein if the calculated depth value is within a set input value, it is determined as normal, and if the calculated depth value is out of the set input value, it is determined as defective, wherein, in the measuring process, the distance measuring member (410) is provided as a displacement sensor, wherein the measuring process further comprises a process of allowing the distance measuring member to move in a full-width direction of the pouch film, which is perpendicular to a transfer direction of the pouch film, so as to adjust a position of the distance measuring member and, wherein the measuring process further comprises a process of allowing the full-width adjusting member to move toward the pouch film so as to adjust a height of the distance measuring member with respect to the pouch film.

6. The method of claim 5, wherein, in the measuring process, the distance from the reference point to the pouch film connected to an upper end of the accommodation part is measured several times within a set range to calculate the first measurement value as an average of the measured distance values.
7. The method of claim 5, wherein, in the measuring process, the distance from the reference point to the bottom surface of the accommodation part is measured several times within a set range to calculate the second measurement value as an average of the measured distance values.
8. The method of claim 6 or 7, wherein the set range is set to 1 mm to 5 mm.
9. The method of claim 5, further comprising, after the inspection process is completed:
 - a cutting process of cutting a portion between the accommodation parts formed in the pouch film to manufacture the pouch; and
 - a removing process of discharging and removing the pouch, in which the accommodation part determined as defective in the inspection process, among the pouches is formed.

Patentansprüche

1. Ausrüstung zum Formen eines Beutels (10), umfassend:
 - eine Transfervorrichtung (100), welche dazu eingerichtet ist, einen Beutelfilm (20) zu transferieren;

eine Formvorrichtung (300), welche dazu eingerichtet ist, eine obere Fläche des Beutelfilms (20), welcher von der Transfervorrichtung transferiert wird, zu pressen, um so einen Aufnahmeteil (11) zum Aufnehmen einer Elektrodenanordnung zu formen; und eine Inspektionsvorrichtung (400), welche dazu eingerichtet ist, einen Tiefenwert des Aufnahmeteils (11) zu berechnen, welcher in dem Beutelfilm (20) gebildet wird, und den berechneten Tiefenwert mit einem festgelegten Eingabewert zu vergleichen, um so zu inspizieren, ob Defekte auftreten, wobei die Inspektionsvorrichtung (400) umfasst:

ein Distanz-Messelement (410), welches an einem Referenzpunkt (O) bereitgestellt ist, welcher oberhalb des Beutelfilms festgelegt ist, um jeden aus einem ersten Messwert (α), welcher eine Distanz von dem Referenzpunkt zu dem Beutelfilm (20) ist, welcher mit einem oberen Ende des Aufnahmeteils (11) verbunden ist, und einem zweiten Messwert (β) zu messen, welcher eine Distanz von dem Referenzpunkt zu einer unteren Fläche des Aufnahmeteils (11) ist; und ein Inspektionselement (420), welches dazu eingerichtet ist, einen Tiefenwert (γ) des Aufnahmeteils (11) zu messen, indem der erste Messwert von dem zweiten Messwert subtrahiert wird, welcher von dem Distanz-Messelement (410) gemessen wird, wobei, wenn der berechnete Tiefenwert (γ) innerhalb eines festgelegten Eingabewerts liegt, er als normal bestimmt wird, und wenn der berechnete Tiefenwert (γ) außerhalb des festgelegten Eingabewerts liegt, er als defektbehaftet bestimmt wird, **dadurch gekennzeichnet, dass** das Distanz-Messelement (410) als ein Verlagerungssensor bereitgestellt ist, wobei die Inspektionsvorrichtung (400) ferner ein Vollbreiten-Anpassungselement (430) umfasst, welches dazu eingerichtet ist, es dem Distanz-Messelement zu erlauben, sich in einer Vollbreiten-Richtung des Beutelfilms (20) zu bewegen, welche senkrecht zu einer Transferrichtung des Beutelfilms ist, um so eine Position des Distanz-Messelements anzupassen, und wobei die Inspektionsvorrichtung ferner ein Höhen-Anpassungselement (440) umfasst, welches dazu eingerichtet ist, es dem Vollbreiten-Anpassungselement (430) zu erlauben, sich in Richtung des Beutelfilms zu bewegen, um so eine Höhe des Distanz-Messelements bezüglich des Beutelfilms anzupassen.

2. Ausrüstung nach Anspruch 1, wobei das Distanz-Messelement (410) die Distanz von dem Referenzpunkt zu dem Beutelfilm, welcher mit einem oberen Ende des Aufnahmeteils (11) verbunden ist, mehrere Male innerhalb eines festgelegten Bereichs misst, um den ersten Messwert als einen Durchschnitt der gemessenen Distanzwerte zu berechnen. 5
3. Ausrüstung nach Anspruch 1, wobei das Distanz-Messelement (410) die Distanz von dem Referenzpunkt zu der unteren Fläche des Aufnahmeteils (11) mehrere Male innerhalb eines festgelegten Bereichs misst, um den zweiten Messwert als einen Durchschnitt der gemessenen Distanzwerte zu berechnen. 10
4. Ausrüstung nach Anspruch 2 oder 3, wobei der festgelegte Bereich auf 1 mm bis 5 mm festgelegt ist. 15
5. Verfahren zum Formen eines Beutels (10), das Verfahren umfassend: 20
- einen Transferprozess eines Transferierens eines Beutelfilms (20);
- einen Formprozess eines Pressens einer oberen Fläche des transferierten Beutelfilms, um einen Aufnahmeteil (11) zum Aufnehmen einer Elektrodenanordnung zu formen; und
- einen Inspektionsprozess eines Berechnens eines Tiefenwerts (γ) des Aufnahmeteils (1), welcher in dem Beutelfilm gebildet wird, und eines Vergleichens des berechneten Tiefenwerts mit einem festgelegten Eingabewert, um zu inspizieren, ob Defekte auftreten, wobei der Inspektionsprozess umfasst: 30
- einen Messprozess eines Messens von jedem aus einem ersten Messwert (α), welcher eine Distanz von dem Referenzpunkt (O) zu dem Beutelfilm ist, welcher mit einem oberen Ende des Aufnahmeteils verbunden ist, und einem zweiten Messwert (β), welcher eine Distanz von dem Referenzpunkt zu einer unteren Fläche des Aufnahmeteils (11) ist, indem ein Distanz-Messelement (410) verwendet wird, welches oberhalb des Beutelfilms bereitgestellt ist; und 40
- einen Inspektionsprozess eines Berechnens eines Tiefenwerts (γ) des Aufnahmeteils, indem der erste Messwert von dem zweiten Messwert subtrahiert wird, welcher von dem Messprozess gemessen wird, wobei, wenn der berechnete Tiefenwert innerhalb eines festgelegten Eingabewerts liegt, er als normal bestimmt wird, und wenn der berechnete Tiefenwert außerhalb des festgelegten Eingabewerts liegt, er als defekt-
- behaftet bestimmt wird, wobei in dem Messprozess das Distanz-Messelement (410) als ein Verlagerungssensor bereitgestellt wird, wobei der Messprozess ferner einen Prozess eines Erlaubens des Distanz-Messelements umfasst, sich in einer Vollbreiten-Richtung des Beutelfilms zu bewegen, welche senkrecht zu einer Transferrichtung des Beutelfilms ist, um so eine Position des Distanz-Messelements anzupassen, und wobei der Messprozess ferner einen Prozess eines Erlaubens des Vollbreiten-Anpassungselements umfasst, sich in Richtung des Beutelfilms zu bewegen, um so eine Höhe des Distanz-Messelements bezüglich des Beutelfilms anzupassen. 16
6. Verfahren nach Anspruch 5, wobei in dem Messprozess die Distanz von dem Referenzpunkt zu dem Beutelfilm, welcher mit einem oberen Ende des Aufnahmeteils verbunden ist, mehrere Male innerhalb eines festgelegten Bereichs gemessen wird, um den ersten Messwert als einen Durchschnitt der gemessenen Distanzwerte zu berechnen. 25
7. Verfahren nach Anspruch 5, wobei in dem Messprozess die Distanz von dem Referenzpunkt zu der unteren Fläche des Aufnahmeteils mehrere Male innerhalb eines festgelegten Bereichs gemessen wird, um den zweiten Messwert als einen Durchschnitt der gemessenen Distanzwerte zu berechnen. 30
8. Verfahren nach Anspruch 6 oder 7, wobei der festgelegte Bereich auf 1 mm bis 5 mm festgelegt wird. 35
9. Verfahren nach Anspruch 5, ferner umfassend, nachdem der Inspektionsprozess abgeschlossen ist: 40
- einen Schneidprozess eines Schneidens eines Abschnitts zwischen den Aufnahmeteilen, welche in dem Beutelfilm gebildet werden, um den Beutel herzustellen; und
- einen Entfernungsprozess eines Abgebens und Entfernens des Beutels, in welchem der Aufnahmeteil, welcher als defektbehaftet in dem Inspektionsprozess bestimmt wird, unter den Beuteln gebildet wird. 45
- 50
- Revendications**
1. Équipement de moulage d'une poche (10), comprenant : 55
- un dispositif de transfert (100) configuré pour

transférer un film de poche (20) ;
 un dispositif de moulage (300) configuré pour presser une surface supérieure du film de poche (20) transféré par le dispositif de transfert de façon à mouler une partie de logement (11) pour loger un ensemble électrode ; et
 un dispositif d'inspection (400) configuré pour calculer une valeur de profondeur de la partie de logement (11) formée dans le film de poche (20) et comparer la valeur de profondeur calculée à une valeur d'entrée définie de façon à inspecter si des défauts se produisent,
 dans lequel le dispositif d'inspection (400) comprend :

un élément de mesure de distance (410) disposé à un point de référence (O) défini au-dessus du film de poche pour mesurer chacune d'une première valeur de mesure (α) qui est une distance du point de référence au film de poche (20) relié à une extrémité supérieure de la partie de logement (11) et d'une deuxième valeur de mesure (β) qui est une distance du point de référence à une surface inférieure de la partie de logement (11) ; et

un élément d'inspection (420) configuré pour calculer une valeur de profondeur (γ) de la partie de logement (11) en soustrayant la première valeur de mesure à la deuxième valeur de mesure mesurée par l'élément de mesure de distance (410), dans lequel, si la valeur de profondeur calculée (γ) se situe dans une valeur d'entrée définie, elle est déterminée comme étant normale, et si la valeur de profondeur calculée (γ) se situe en dehors de la valeur d'entrée définie, elle est déterminée comme étant défectueuse, **caractérisé en ce que** l'élément de mesure de distance (410) est fourni en tant que capteur de déplacement, dans lequel le dispositif d'inspection (400) comprend en outre un élément de réglage de pleine largeur (430) configuré pour permettre à l'élément de mesure de distance de se déplacer dans une direction de pleine largeur du film de poche (20), qui est perpendiculaire à une direction de transfert du film de poche, de façon à régler une position de l'élément de mesure de distance et dans lequel le dispositif d'inspection comprend en outre un élément de réglage de hauteur (440) configuré pour permettre à l'élément de réglage de pleine largeur (430) de se déplacer vers le film de poche de façon à régler une hauteur de l'élément de mesure de distance par rapport au film de poche.

2. Équipement selon la revendication 1, dans lequel l'élément de mesure de distance (410) mesure la distance du point de référence au film de poche relié à une extrémité supérieure de la partie de logement (11) plusieurs fois dans une plage définie pour calculer la première valeur de mesure en tant que moyenne des valeurs de distance mesurées.
3. Équipement selon la revendication 1, dans lequel l'élément de mesure de distance (410) mesure la distance du point de référence à la surface inférieure de la partie de logement (11) plusieurs fois dans une plage définie pour calculer la deuxième valeur de mesure en tant que moyenne des valeurs de distance mesurées.
4. Équipement selon la revendication 2 ou 3, dans lequel la plage définie est définie sur 1 mm à 5 mm.
5. Procédé de moulage d'une poche (10), le procédé comprenant :

un processus de transfert d'un film de poche (20) ;

un processus de moulage consistant à presser une surface supérieure du film de poche transféré pour mouler une partie de logement (11) afin de loger un ensemble électrode ; et

un processus d'inspection consistant à calculer une valeur de profondeur (γ) de la partie de logement (1) formée dans le film de poche et à comparer la valeur de profondeur calculée à une valeur d'entrée définie pour inspecter si des défauts se produisent,
 dans lequel le processus d'inspection comprend :

un processus consistant à mesurer chacune d'une première valeur de mesure (α) qui est une distance d'un point de référence (O) au film de poche relié à une extrémité supérieure de la partie de logement et d'une deuxième valeur de mesure (β) qui est une distance du point de référence à une surface inférieure de la partie de logement (11) en utilisant un élément de mesure de distance (410) disposé au-dessus du film de poche ; et

un processus d'inspection consistant à calculer une valeur de profondeur (γ) de la partie de logement en soustrayant la première valeur de mesure à la deuxième valeur de mesure mesurée dans le processus de mesure, dans lequel, si la valeur de profondeur calculée se situe dans une valeur d'entrée définie, elle est déterminée comme étant normale, et si la valeur de profondeur calculée se situe en dehors de

la valeur d'entrée définie, elle est déterminée comme étant défectueuse, dans lequel, dans le processus de mesure, l'élément de mesure de distance (410) est fourni en tant que capteur de déplacement, dans lequel le processus de mesure comprend en outre un processus consistant à permettre à l'élément de mesure de distance de se déplacer dans une direction de pleine largeur du film de poche, qui est perpendiculaire à une direction de transfert du film de poche, de façon à régler une position de l'élément de mesure de distance et, dans lequel le processus de mesure comprend en outre un processus consistant à permettre à l'élément de réglage de pleine largeur de se déplacer vers le film de poche de façon à régler une hauteur de l'élément de mesure de distance par rapport au film de poche.

- 5
10
15
20
6. Procédé selon la revendication 5, dans lequel, dans le processus de mesure, la distance du point de référence au film de poche relié à une extrémité supérieure de la partie de logement est mesurée plusieurs fois dans une plage définie pour calculer la première valeur de mesure en tant que moyenne des valeurs de distance mesurées. 25
7. Procédé selon la revendication 5, dans lequel, dans le processus de mesure, la distance du point de référence à la surface inférieure de la partie de logement est mesurée plusieurs fois dans une plage définie pour calculer la deuxième valeur de mesure en tant que moyenne des valeurs de distance mesurées. 30
35
8. Procédé selon la revendication 6 ou 7, dans lequel la plage définie est définie sur 1 mm à 5 mm.
9. Procédé selon la revendication 5, comprenant en outre, une fois le processus d'inspection terminé : 40
- un processus de découpe consistant à découper une partie entre les parties de logement formées dans le film de poche pour fabriquer la poche ; et 45
- un processus de retrait consistant à décharger et à retirer, parmi les poches, la poche dans laquelle est formée la partie de logement déterminée comme étant défectueuse dans le processus d'inspection. 50

55

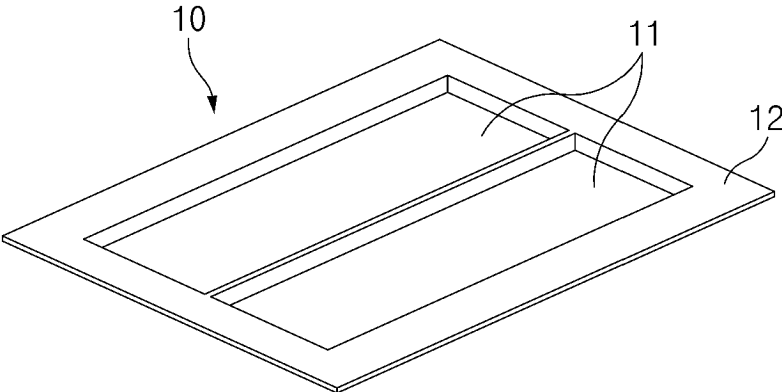

FIG.1

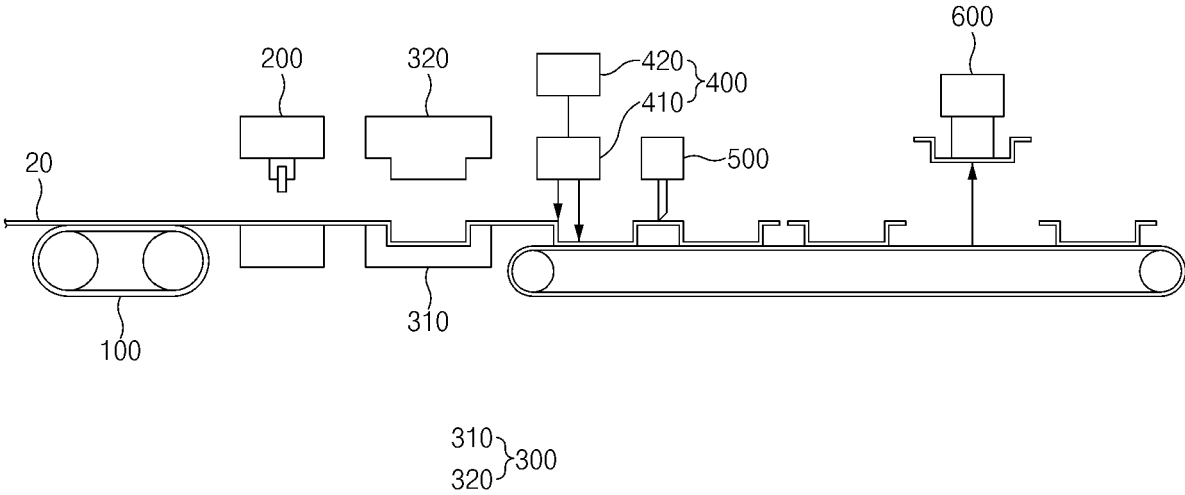

FIG.2

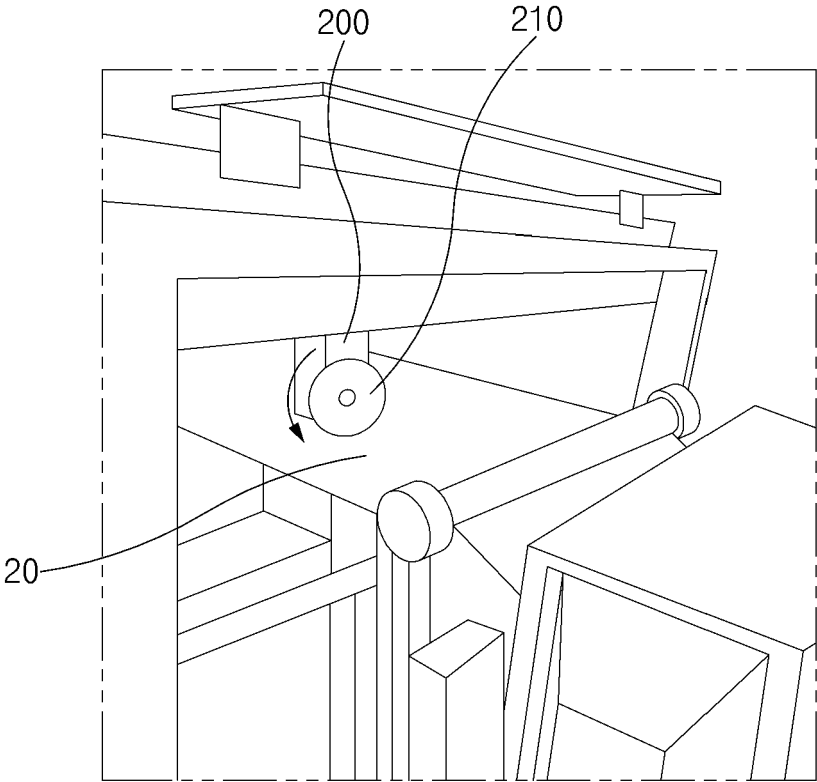

FIG. 3

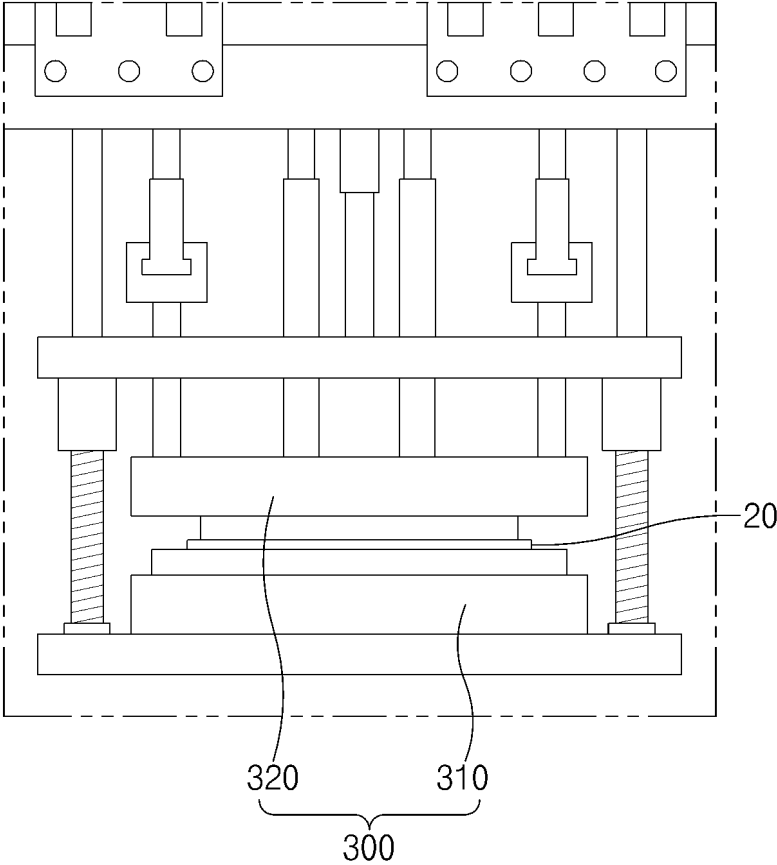

FIG.4

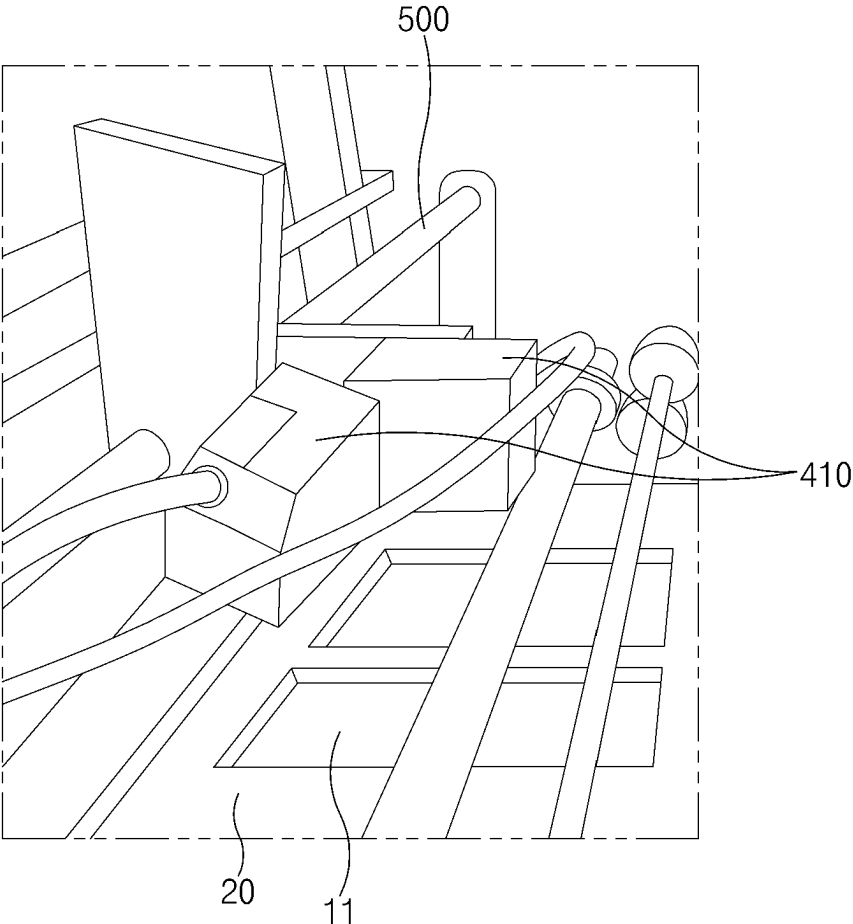

FIG.5

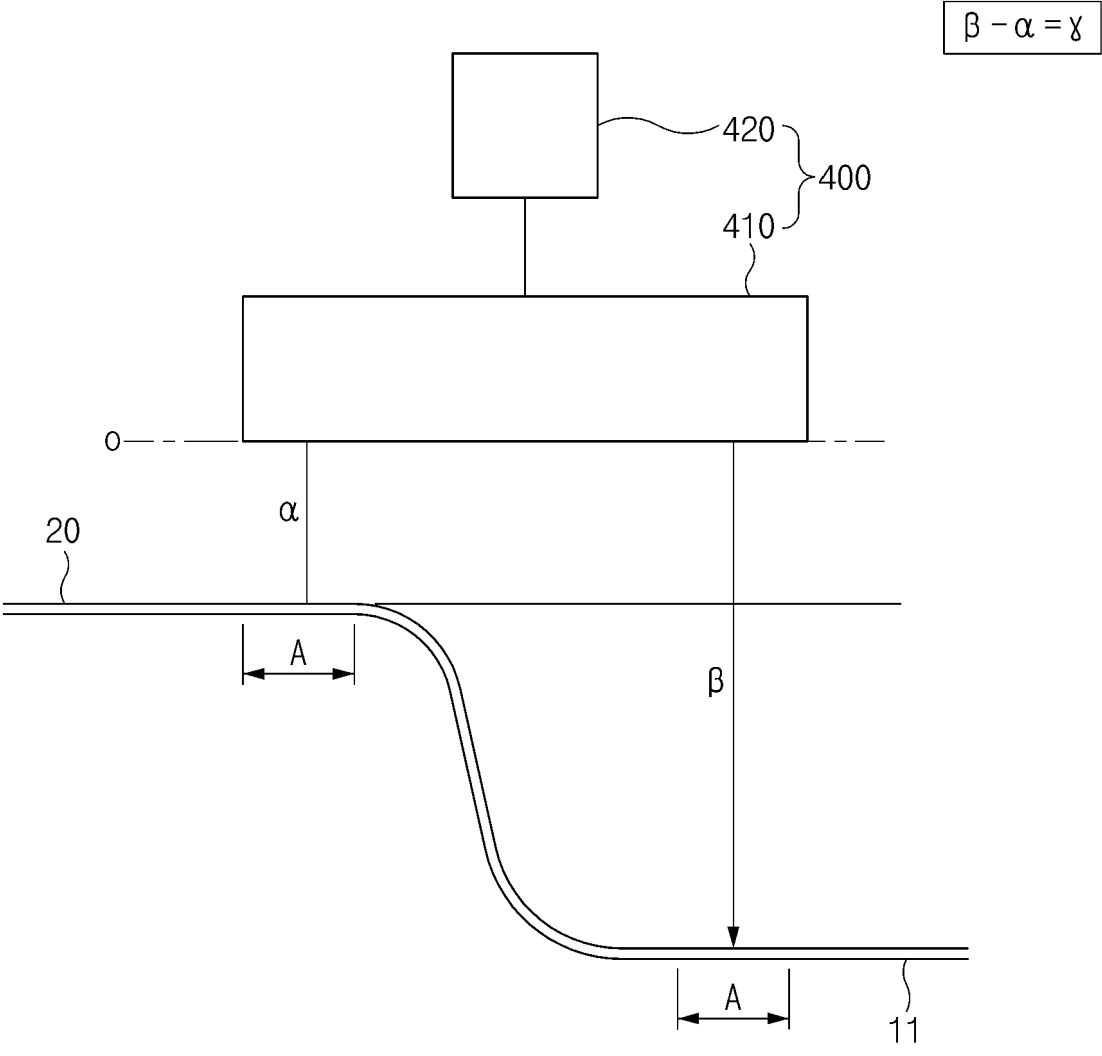

FIG.6

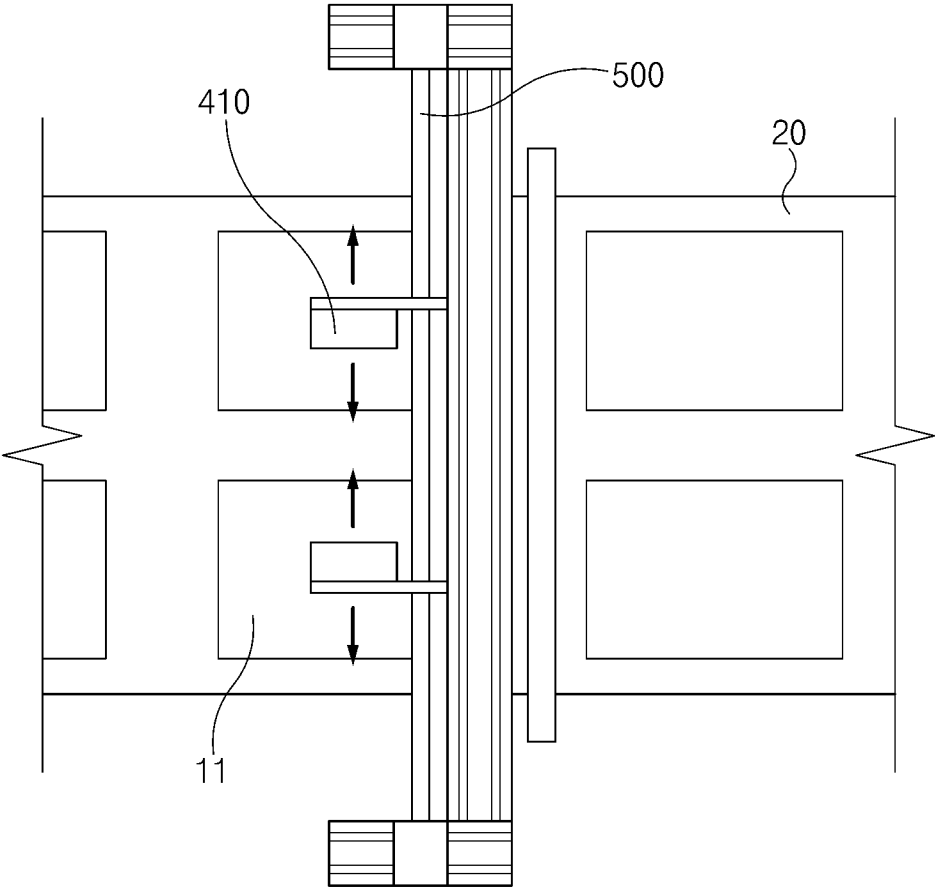

FIG.7

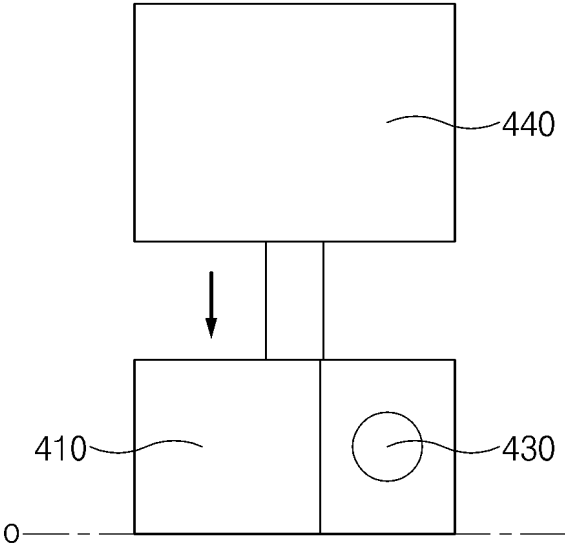

FIG.8

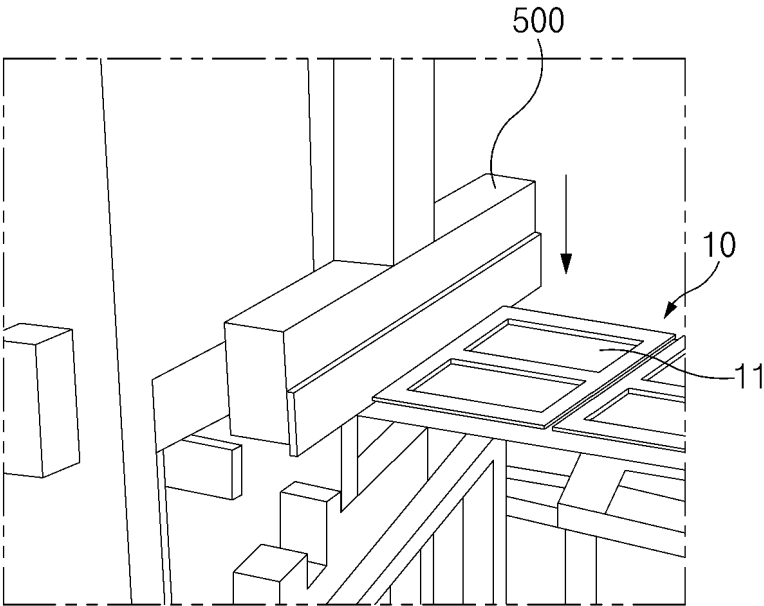

FIG.9

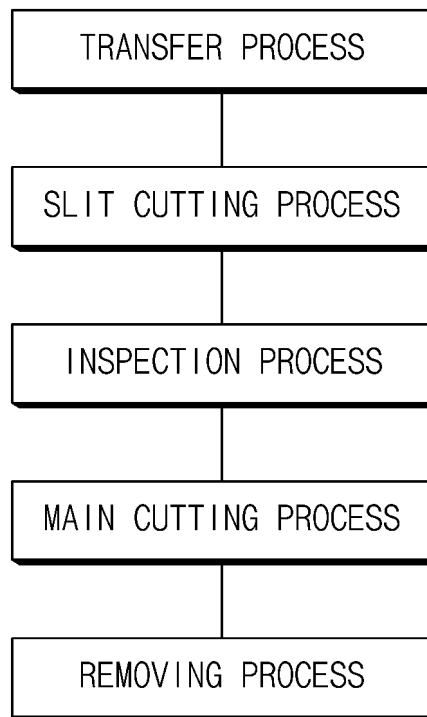

FIG.10

REFERENCES CITED IN THE DESCRIPTION

This list of references cited by the applicant is for the reader's convenience only. It does not form part of the European patent document. Even though great care has been taken in compiling the references, errors or omissions cannot be excluded and the EPO disclaims all liability in this regard.

Patent documents cited in the description

- KR 20150026172 A [0008]
- WO 2021112481 A1 [0008]