

(19) World Intellectual Property Organization  
International Bureau



(43) International Publication Date  
12 March 2009 (12.03.2009)

PCT

(10) International Publication Number  
**WO 2009/031865 A2**

(51) International Patent Classification:  
*F03B 7/00* (2006.01)

(74) Agent: **JANG, Soo-Young**; Rm. 1610, Hyundai Venture-  
tel, 642-1 Yeoksam 1-dong, Gangnam-gu, Seoul 135-910  
(KR).

(21) International Application Number:  
PCT/KR2008/005274

(81) Designated States (unless otherwise indicated, for every  
kind of national protection available): AE, AG, AL, AM,  
AO, AT, AU, AZ, BA, BB, BG, BH, BR, BW, BY, BZ, CA,  
CH, CN, CO, CR, CU, CZ, DE, DK, DM, DO, DZ, EC, EE,  
EG, ES, FI, GB, GD, GE, GH, GM, GT, HN, HR, HU, ID,  
IL, IN, IS, JP, KE, KG, KM, KN, KP, KZ, LA, LC, LK, LR,  
LS, LT, LU, LY, MA, MD, ME, MG, MK, MN, MW, MX,  
MY, MZ, NA, NG, NI, NO, NZ, OM, PG, PH, PL, PT, RO,  
RS, RU, SC, SD, SE, SG, SK, SL, SM, ST, SV, SY, TJ, TM,  
TN, TR, TT, TZ, UA, UG, US, UZ, VC, VN, ZA, ZM, ZW.

(22) International Filing Date:  
8 September 2008 (08.09.2008)

(25) Filing Language: Korean

(26) Publication Language: English

(30) Priority Data:  
10-2007-0091840  
7 September 2007 (07.09.2007) KR  
10-2008-0088022  
8 September 2008 (08.09.2008) KR

(84) Designated States (unless otherwise indicated, for every  
kind of regional protection available): ARIPO (BW, GH,  
GM, KE, LS, MW, MZ, NA, SD, SL, SZ, TZ, UG, ZM,  
ZW), Eurasian (AM, AZ, BY, KG, KZ, MD, RU, TJ, TM),  
European (AT, BE, BG, CH, CY, CZ, DE, DK, EE, ES, FI,  
FR, GB, GR, HR, HU, IE, IS, IT, LT, LU, LV, MC, MT, NL,  
NO, PL, PT, RO, SE, SI, SK, TR), OAPI (BF, BJ, CF, CG,  
CI, CM, GA, GN, GQ, GW, ML, MR, NE, SN, TD, TG).

(71) Applicant and  
(72) Inventor: **PARK, Jongwon** [KR/KR]; 176, Gomo-ri, Jil-  
lye-myeon, Gimhae-si, Gyeongsangnam-do 621-881 (KR).

[Continued on next page]

(54) Title: WHEEL HAVING NABI BLADE

[Fig. 1]

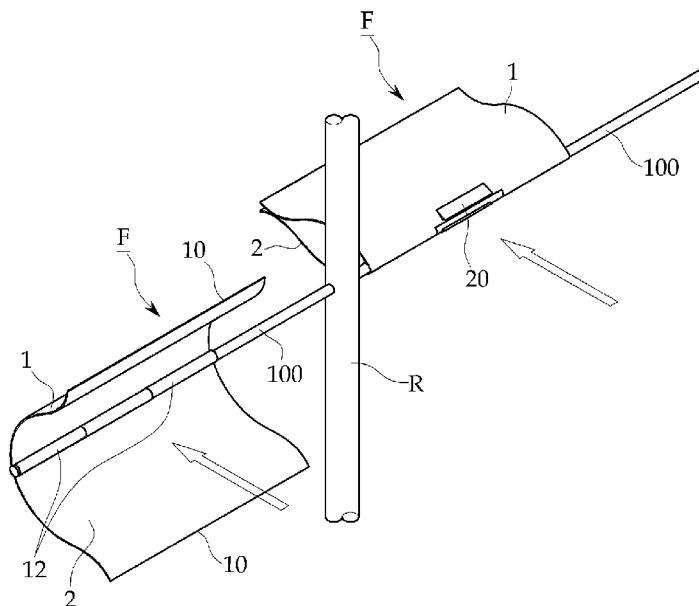

(57) Abstract: The present invention discloses a wheel having a NABI blade for a power generation apparatus whose shape is variably changed according to a rotational position corresponding to a flow of external force in nature. The wheel having the NABI blade for the power generation apparatus includes a rotational shaft; an arm installed on the rotational shaft in a right angle; and a plurality of blades that is foldably installed on the arm, sequentially changes its shape according to a rotational position, and has a bucket shape upon opening.

WO 2009/031865 A2



**Published:**

- *without international search report and to be republished upon receipt of that report*

## Description

### WHEEL HAVING NABI BLADE

#### Technical Field

- [1] The present invention relates to a wheel for a power generation apparatus, and more specifically, to a wheel for a NABI blade for a power generation apparatus capable of obtaining maximum power through a shape conversion of moving energy without applying separate artificial energy.

#### Background Art

- [2] Many studies on new and renewable energy, such as water power, wind turbine, geothermal, solar photovoltaic, and small hydro other than energy using atomic energy or fossil fuel have been attempted, but are accompanied by high construction costs, environmental damage, and economical efficiency degradation of energy harvesting efficiency. In particular, in the water power generation that generates power by rotating a turbine using position energy generated by falling running water from an upper of a dam to a lower of a dam, high-efficiency power generation can be achieved using specific gravity and flow velocity of water as compared with wind power generation.
- [3] However, the method of the water power generation in the related art inevitably needs the building of the dam incurring enormous expenses and damages a natural ecosystem by interrupting the flow of the river or stream. Therefore, a need exists for a method of water power generation of low expense without leading to the environmental damage.

#### Disclosure of Invention

##### Technical Problem

- [4] The present invention proposes to solve the problems in the related art. It is an object of the present invention to provide a wheel having a NABI blade for a power generation apparatus capable of obtaining maximum power (rotatory power) with a very economical and eco-friendly method from moving energy, such as water, wind.
- [5] It is another method of the present invention to provide a wheel having a NABI blade for a power generation apparatus capable of maximizing power (rotatory power) obtained from moving energy in nature, such as running water or wind.
- [6] It is still another object of the present invention to provide a wheel having a NABI blade for a power generation apparatus, which can be easily installed and performed without experiencing a significant effect from an installation position or condition.

##### Technical Solution

- [7] In order to achieve the above-mentioned objects, there is provided a wheel having a NABI blade for a power generation apparatus including: a rotational shaft; an arm

installed on the rotational shaft in a right angle; and a plurality of blades that is foldably installed on the arm, sequentially changes its shape according to a rotational position, and has a bucket shape upon opening.

- [8] The blade is configured to have a streamline when each blade is folded.
- [9] Each blade is configured as first and second loading blades, such that they can be hinge-coupled to the arm and can be folded and opened.
- [10] Each of the first and second loading blades is opened independently when the front thereof receives the moving energy upon viewing from the opened inlet side of the blade and is closed independently when the rear thereof receives the moving energy.
- [11] The first and second loading blades whose cross section is a wave shape are formed to be opposite to each other.
- [12] The hinge-coupled position of the first and second loading blades is formed with an open stopper that is limited not to be opened at a predetermined angle.
- [13] The blade is further installed with a guide blade with an angle from the outermost position of the blade toward the rotational shaft so as to exert a function of confining the moving energy receiving the moving energy in the bucket shape when receiving the moving energy and to more easily perform the rotation of the wheel.
- [14] The guide blade is tiltly installed toward the rotational shaft and the front end thereof is positioned to be distantly spaced from the rotational shaft and the rear end thereof is positioned to be adjacent to the rotational shaft.
- [15] The guide blade is integrally installed with the arm at the outermost position of the blade or the inner surface of the blade upwardly or downwardly.
- [16] The guide blade is integrally installed with the arm at the inner surface of the first or second loading blade or the outer sides of the first or second blades upwardly or downwardly and the first or second loading blade opposed to each other is inserted with the guide blade to form a guided slit.
- [17] Each of the coupling parts of the first and second loading blades is formed with insertion hollow parts in which the arm is slidably fitted.
- [18] Each of the first and second loading blades is formed with the insertion hollow part so that each blade is slidable at the hinged-coupling part with the arm.
- [19] The inlet side ends of the first and second loading blade are formed with ends bent outwardly so that the front surfaces of the first and second loading blades receive the moving energy when viewing from the inlet side at which the blade is opened.
- [20] The inner surfaces of the inlet sides of the first and second loading blades are formed with a plurality of opening plates in one body.
- [21] A spring is functionally installed on the hinge or the arm so that the first and second loading blades are easily opened if the front surfaces of the first and second blades receive the moving energy when viewing from the inlet side at which the blade is

opened.

[22] At least one check valve is installed on a rear surface of each of the first and second loading blades so that the first and second loading blades are easily opened if the front surfaces of the first and second blades receive the moving energy when viewing from the inlet side at which the blade is opened.

[23] Each arm is functionally connected to an auxiliary arm.

[24] The one surface of the respective first and second loading blades is installed with a ring or a clip that is operated by the external force and performs a role of binding not to open the respective loading blades any more when the first and second loading blades are closed in order for a worker to stop the rotation of the wheel in a repair or an emergency.

[25] A portion of the rotational shaft is installed with a brake lining in order for a worker to stop the rotation of the wheel in a repair or an emergency.

### **Advantageous Effects**

[26] The wheel having the NABI blade for the power generation apparatus according to the present invention includes at least two blades whose shape is variably changed according to the rotational position corresponding to the flow of the external force in nature such that it has a structure receiving a maximum load and a structure receiving a minimum load, respectively, making it possible to minimize the yield loss of the natural moving energy, such as water power, tidal power, wind power and generate the maximum power. In particular, in the water power generation, the present invention can easily obtain the power without having the dam or the reservoir.

### **Brief Description of the Drawings**

[27] The above and other objects, features and advantages of the present invention will become apparent from the following description of preferred embodiments given in conjunction with the accompanying drawings, in which:

[28] FIG. 1 is a perspective view showing a first embodiment of a wheel having a NABI blade for a power generation apparatus according to the present invention;

[29] FIG. 2 is a side view showing the first embodiment of the wheel having the NABI blade for the power generation apparatus according to the present invention;

[30] FIG. 3 is a perspective view showing a second embodiment of a wheel having a NABI blade for a power generation apparatus according to the present invention;

[31] FIG. 4 is a side view showing the second embodiment of the wheel having the NABI blade for the power generation apparatus according to the present invention;

[32] FIG. 5 is an operational state view showing an example of the second embodiment of the wheel having the NABI blade for the power generation apparatus according to the present invention;

- [33] FIGS. 6 and 7 are views showing a changed example of the second embodiment of the wheel having the NABI blade for the power generation apparatus according to the present invention;
- [34] FIG. 8 is a view showing another embodiment of a wheel having a NABI blade for a power generation apparatus according to the present invention;
- [35] FIG. 9 is a view showing still another embodiment of a wheel having a NABI blade for a power generation apparatus according to the present invention; and
- [36] FIG. 10 is a view showing still yet another embodiment of a wheel having a NABI blade for a power generation apparatus according to the present invention.
- [37] [Detailed Description of Main Elements]
- [38] 1: FIRST LOADING BLADE
- [39] 2: SECOND LOADING BLADE
- [40] 3: GUIDE PLATE
- [41] 6: OPENING PLATE
- [42] 7: SPRING
- [43] 8: CHECK VALVE
- [44] 10: BENT END
- [45] 12: INSERTION HOLLOW PART
- [46] 20: OPEN STOPPER
- [47] 40: SLIT

### **Best Mode for Carrying Out the Invention**

- [48] The present inventors completes the present invention based on the recognition that the maximum power (rotatory power) can be obtained a difference in loads generated from the moving energy when the shapes of a plurality of blades obtaining power (rotatory power) by receiving moving energy in nature flowing in one direction, such as running water, wind power, tidal power are changed according to the rotational position.
- [49] Hereinafter, a wheel having a NABI blade for a power generation apparatus according to the present invention will be described with reference to the accompanying drawings.
- [50] A NABI blade according to the present invention is referred by changing its shape according to the rotational position through the operation that the blade is opened or closed like an operation of wings of a butterfly
- [51] FIG. 1 is a perspective view showing a first embodiment of a wheel having a NABI blade for a power generation apparatus according to the present invention and FIG. 2 is a side view showing the first embodiment of the wheel having the NABI blade for the power generation apparatus according to the present invention.

- [52] As shown in FIGS. 1 and 2, the first embodiment of the wheel having the NABI blade for the power generation apparatus according to the present invention includes a rotational shaft R, an arm installed on the rotational shaft in a right angle, and a plurality of blades F foldably installed on the arm 100.
- [53] The rotational shaft R is installed or fixed in a vertical direction or a horizontal direction with respect to one direction of the moving energy and the upper and lower ends thereof is rotatably installed on a frame (not shown) by installing a bearing on the upper and lower ends. Further, the rotational shaft R can be connected to various power generation facility and used for generating electricity or energy using a separate power transfer apparatus. The wheel having the NABI blade for the power generation apparatus according to the present invention may be mounted on any generating plants or energy conversion apparatuses. The generating plants and energy conversion apparatuses are already known and therefore, the concrete description thereof will not be repeated.
- [54] The arm 100, which is a circular bar shape, may be installed on an outer side of the rotational shaft R in a horizontal direction. The installation number may be increased or reduced at any time if necessary. In particular, a structure in various forms capable of supporting stress generated from the blade is preferred. When the length of the arm is long, an auxiliary arm connecting and supporting between arms may further be installed.
- [55] The shape of each blade F is sequentially changed according the rotational position. In particular, when the blade F is opened, it is preferable to have a bucket shape containing water.
- [56] The bucket shape of the blade has much velocity (flow velocity) and volume of moving energy in nature, such as water or fluid so that it can obtain the maximum power (rotatory power) from the same moving energy.
- [57] The blade F is configured of first and second loading blades 1, 2 so that it is hinge-coupled to the arm 100 to be folded or opened. In other words, the first and second loading blades 1, 2 have a foldable structure therebetween. Therefore, the first and second blades 1, 2 are opened maximally at a position where the inlet side of the blade F is opposite to the flow of fluid to obtain a maximum load and the first and second loading blades 1, 2 of the blade F are folded at a position where the hinge coupling part of the blade F is opposite to the flow of fluid to obtain a minimum load. Consequently, the blade F has a structure where the blade F generating power receives the maximum load and the blade F not generating power receives the minimum load.
- [58] The first and second loading blades 1, 2 whose cross section is a wave shape are formed to be opposite to each other. Therefore, it is preferable that the blade F has a streamlined shape when the first and second blades 1, 2 are folded.

- [59] Also, each of the hinge coupling part of the first and second loading blades 1, 2 may further be formed with an insertion hollow part 12 into which the arm 100 is slidably fitted. Thereby, the first and second loading blades 1, 2 can be slid to the arm 100 any one time.
- [60] As shown in FIG. 2, the hinge-coupled position of the first and second loading blades 1, 2 is formed with an open stopper 20 so that the first and second loading blades 1, 2 are not opened above a predetermined angle.
- [61] Also, each of the inlet-side ends of the first and second loading blades 1, 2 is formed with ends 10 bent outwardly so that the first and second loading blades 1, 2 can easily be opened when the bent end 10 contacts fluid.
- [62] FIG. 3 is a perspective view showing a second embodiment of a wheel having a NABI blade for a power generation apparatus according to the present invention and FIG. 4 is a side view showing the second embodiment of the wheel having the NABI blade for the power generation apparatus according to the present invention.
- [63] As shown in FIGS. 3 and 4, the wheel having the NABI blade for the power generation apparatus according to the second embodiment has a guide blade 3 that is further installed inside of one side of the blade F. The guide blade 3 is integrally installed upwardly in the inner surface of the second loading blade 2. Also, a slit 40 is formed into the inner surface of the first loading blade 1 so that the guide blade 3 is inserted and guided.
- [64] The guide blade 3 is applied with much load to perform a role of generating the maximum power (rotary power) by sufficiently confining fluid in the inside of the first and second loading blades 1, 2 in the state where the blade F1 is opened. In other words, the guide blade can expand by a receiving function of the moving energy and can increase the rotatory power.
- [65] In order to help the understanding, in the description of the second embodiment of the present invention, a left blade is defined by a sign, 'F1' and a right blade is defined by a sign, 'F2'.
- [66] Since the guide blade 3 is tiltedly installed with an angle to the flow direction of fluid, as shown in FIG. 3, if the insertion hollow part is formed in the first and second loading blades to be fitted into the outside of the arm 100, the left blade F1 can be slid to a side apart from the rotational axis R beyond the arm 100. On the other hand, the right blade F2 is slid to a side adjacent to the rotational shaft R beyond the arm 100.
- [67] The blade F1 is positioned at the outermost side of the arm 100 in a state where the first and second loading blades 1, 2 are opened through the above-mentioned operation to make resistance against fluid large, making it possible to obtain the maximum power (rotary power) and the blade F2 is positioned at the innermost side of the arm 100 in a state where the first and second loading blades 1, 2 are folded, making it possible to

largely reduce resistance force against fluid.

[68] As shown in FIG. 4, it is preferred that the guide blade 3 is tiltly formed as going from the front end to the rear end. However, the guide blade 3 is not necessarily formed to be tilted and may be formed in a right angle.

[69] The 'front end' is a direction into where the fluid is entered and the 'rear end' defines the opposite direction.

[70] The guide blade 3 attached to the inner surface of the first and second loading blade 1, 2, which is installed upwardly by penetrating through the slit 40, is moved forwardly and backwardly within the slit 40 according to the rotational movement of the blade F1, F2.

[71] Therefore, the length of the slit 40 should be formed to be more lengthened than the length of the width of the guide blade 3 in consideration of the opened and closed angle of the first and second loading blades 1, 2 and can variously be changed in consideration of the opened angle of the first and second loading blades 1, 2.

[72] Also, it is preferable that the structure and angle of the guide blade 3 are set in order to further increase the rotatory power as a guide flag when the first and second loading blades 1, 2 are rotated based on the rotational axis R, excepting that the angle of the guide blade 3 is used as the slide usage.

[73] Further, it is preferable that the guide blade 3 has a height enough to be projected to the upper direction of the first loading blade when the blade F1 is completely opened. Since the guide blade 3 can be rotated only by the length of the slit 40, the extent where the first and second loading blades 1, 2 are opened can be controlled.

[74] FIG. 5 is an operational state view showing an example of the second embodiment of the wheel having the NABI blade for the power generation apparatus according to the present invention.

[75] Referring to FIG. 5, describing the operation relation of the present invention, in the left based on FIG. 5, the first and second loading blades 1, 2 are folded when the blade F impacts on the fluid, such that the fluid pressure is operated to generate power (rotatory power) in a state where they are opened. At this time, the fluid pressure applied to the inside of the blade F1 pushes the guide blade 3 together, so that the blade F1 is moved left in a horizontal direction so that it is pushed at a distant position from the rotational shaft R. The blade F is distant from the rotational shaft R so that the fluid pressure applied to the blade F1 becomes further large.

[76] Continuously, the pressure of fluid is applied to the rear surface of the blade F1 while the blade F1 is rotated, such that the blade is slowly closed. Therefore, the blade is slowly closed to form the blade F2.

[77] Meanwhile, when the blade F2 is positioned at the right based on FIG. 5, the fluid applies a pressure to the rear of the blade F2, such that the first and second loading

blades 1, 2 are completely folded. Since the resistance against the flow of fluid is small in the state where the blade F2 is completely folded, the load applied to the blade F2 is minimized.

[78] Further, the pressure of fluid is applied to other sides of the guide blade 3 by the tilted angle of the guide blade 3 to move at the blade F2 into the left direction (rotational shaft direction), thereby positioning the position adjacent to the rotational shaft R. The blade F2 is positioned to be adjacent to the rotational shaft R, making it possible to largely reduce the resistance force of the blade F2 against the flow of fluid.

[79] FIGS. 6 and 7 are views showing a changed example of the second embodiment of the wheel having the NABI blade for the power generation apparatus according to the present invention.

[80] As shown in FIG. 6, a guide blade 3b is installed on the end of the arm 100.

[81] As shown in FIG. 7, a guide blade 3c is mounted on the end of any one of the first and second loading blades 1, 2.

[82] The shape and installation angle of the guide blades 3b, 3c shown in FIGS. 6 and 7 are the same as the guide plate 3 and the role and action thereof are the same. Therefore, the repeated description thereof will be omitted.

[83] Meanwhile, FIG. 8 is a view showing another embodiment of a wheel having a NABI blade for a power generation apparatus according to the present invention.

[84] The inner surfaces of the first and second loading blades 1, 2 are formed with a plurality of opening plates to be opposite to each other at a position adjacent the bent end 10, such that the opening plates 6 contact each other to form a gap when the first and second loading blades 1, 2 are folded.

[85] The opening plate 6 is installed to more facilitate the open of the front end of the first and second loading blades 1, 2. The shape of the opening plate is not significantly limited. As a material, a kind of steel, a kind of rubber, or silicon, etc. is preferred.

[86] The plurality of opening plates 6 are formed at a predetermined interval, such that the fluid through the gap can be introduced. The open of the first and second loading blades 1, 2 can more rapidly be performed by the opening plate 6.

[87] Meanwhile, FIG. 9 is a view showing still another embodiment of a wheel having a NABI blade for a power generation apparatus according to the present invention.

[88] As shown in FIG. 9, if the front surface of the first and second loading blades 1, 2 receives the moving energy when viewing from the inlet side at which the blade is opened, the first and second loading blades 1, 2 are more easily opened, such that the spring 7 can functionally be installed on the hinge or the arm 100.

[89] The spring 7 is suitable for a torsion spring and both ends thereof is installed to be elastically supported on the inner surface of the first and second loading blades 1, 2.

[90] Meanwhile, FIG. 10 is a view showing still yet another embodiment of a wheel

having a NABI blade for a power generation apparatus according to the present invention.

- [91] As shown in FIG. 10, if the front surface of the first and second loading blades 1, 2 receives the moving energy when viewing from the inlet side at which the blade is opened, the first and second loading blades 1, 2 are more easily opened, such that at least one check valve 8 may be installed on the rear surfaces of the first and second loading blade 1, 2.
- [92] Such a check valve 8 forms a through hole 81 in the first and second loading blades 1, 2 and is configured by hinge-coupling a disk 82 to the inner surface of the first and second loading blades 1, 2 to interrupt the through hole 81.
- [93] Therefore, when receiving the load of fluid, the check valve is closed to interrupt the pass of fluid, such that it pushes the first and second loading blades 1, 2 to help the open thereof and when not receiving the load of fluid, the check valve is opened to passes through water and distribute load, making it possible to make the load difference large.
- [94] Also, the one surface of the respective first and second loading blades can be installed with a ring or a clip that performs a role of binding so that the first and second loading blades are not opened in order for a worker to stop the rotation of the wheel in a repair or an emergency.
- [95] Also, a usual brake apparatus can be installed on a portion of the rotational shaft R in order to a worker to stop the rotation of the wheel in a repair or an emergency.
- [96] Those skilled in the art will appreciate that the conceptions and specific embodiments disclosed in the foregoing description may be readily utilized as a basis for modifying or designing other embodiments for carrying out the same purposes of the present invention. Those skilled in the art will also appreciate that such equivalent embodiments do not depart from the spirit and scope of the invention as set forth in the appended claims.
- [97]

## Claims

- [1] A wheel having a NABI blade for a power generation apparatus including:  
a rotational shaft;  
an arm installed on the rotational shaft in a right angle; and  
a plurality of blades that is foldably installed on the arm, sequentially changes its shape according to a rotational position, and has a bucket shape upon opening.
- [2] The wheel having a NABI blade according to claim 1, wherein the blade is configured to have a streamline when each blade is folded.
- [3] The wheel having a NABI blade according to claim 1, wherein each blade is configured as first and second loading blades, such that they can be hinge-coupled to the arm and can be folded and opened.
- [4] The wheel having a NABI blade according to claim 3, wherein each of the first and second loading blades is opened independently when the front thereof receives the moving energy upon viewing from the opened inlet side of the blade and is closed independently when the rear thereof receives the moving energy.
- [5] The wheel having a NABI blade according to claim 3, wherein the first and second loading blades whose cross section is a wave shape are formed to be opposite to each other.
- [6] The wheel having a NABI blade according to claim 3, wherein the hinge-coupled position of the first and second loading blades is formed with an open stopper that is limited not to be opened at a predetermined angle.
- [7] The wheel having a NABI blade according to claim 3, wherein the blade is further installed with a guide blade for expanding a receiving function of moving energy and increasing a rotatory power in the blade.
- [8] The wheel having a NABI blade according to claim 3, wherein the hinge coupling parts of the first and second loading blades or the arm and the hinge coupling portions are formed with insertion hollow parts in which the arm is slidably fitted.
- [9] The wheel having a NABI blade according to claim 3, wherein the first and second loading blade is further formed with ends bent outwardly to the inlet side end so that they are easily opened if the front surfaces of the first and second loading blades are formed with the moving energy.
- [10] The wheel having a NABI blade according to claim 3, wherein the inner surfaces of the inlet sides of the first and second loading blades are further formed with a plurality of opening plates.
- [11] The wheel having a NABI blade according to claim 3, wherein the first and second loading blades is further installed with a spring so that they are easily

opened if the front surface thereof receive the moving energy.

[12] The wheel having a NABI blade according to claim 3, wherein the first and second loading blade is further installed with a check valve.

[13] The wheel having a NABI blade according to claim 3, wherein each arm is further installed with an auxiliary arm.

[Fig. 1]

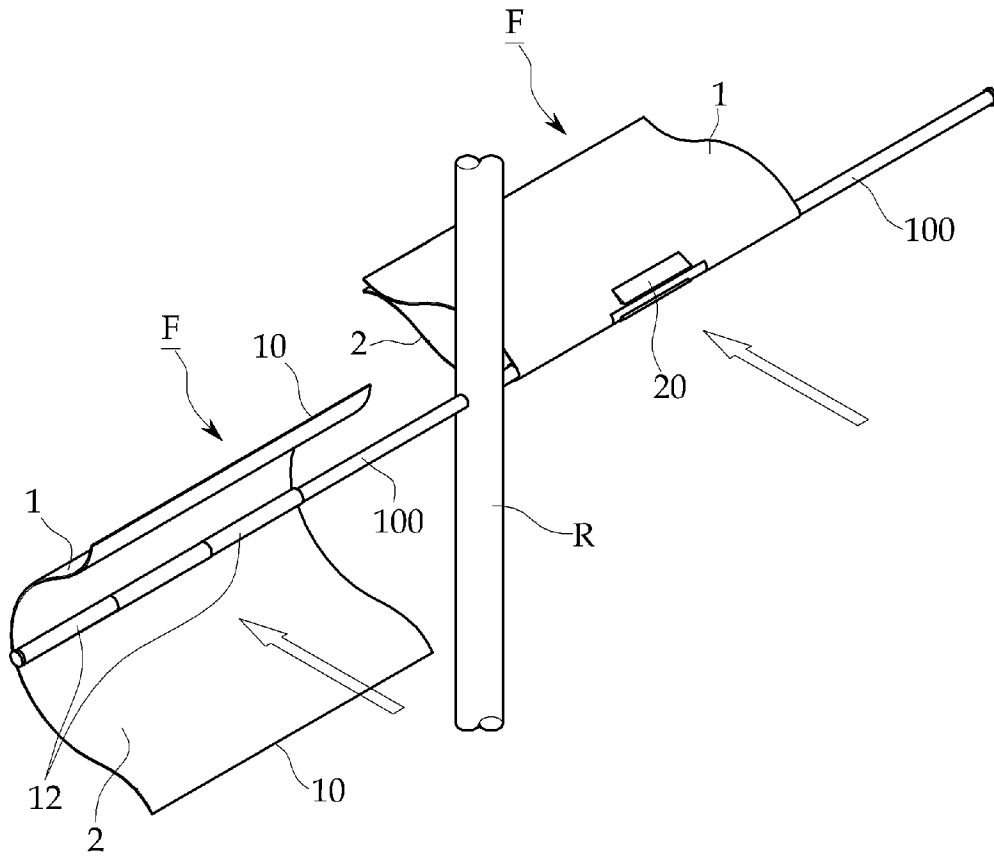

[Fig. 2]

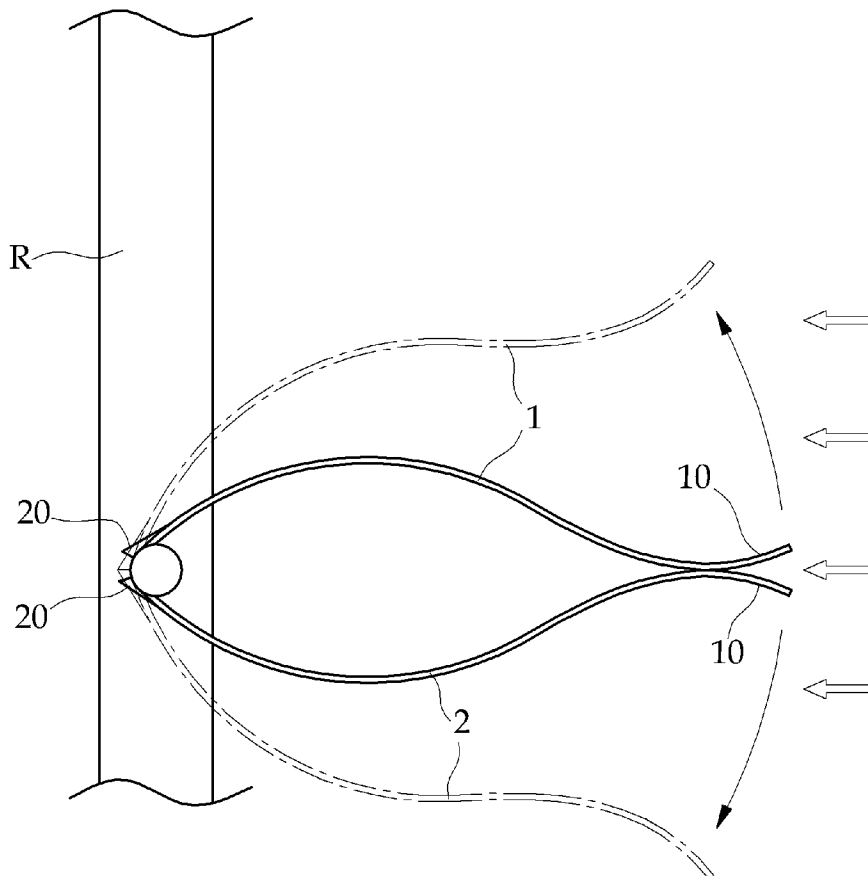

[Fig. 3]

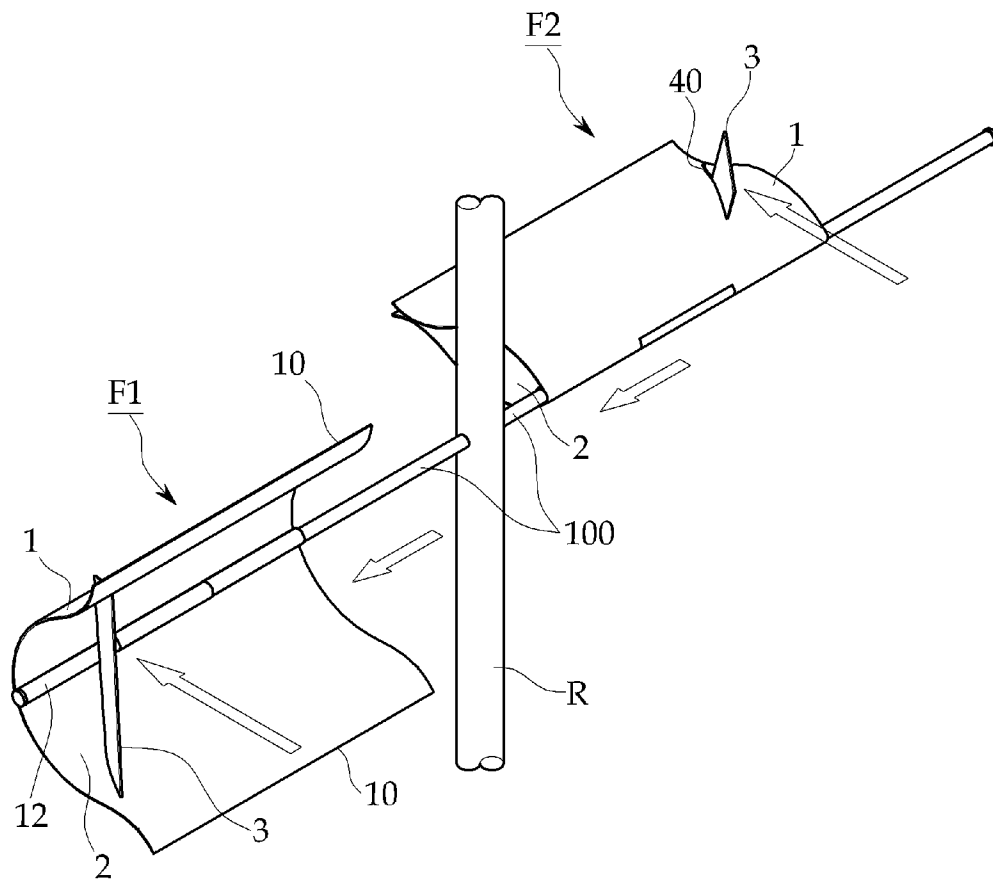

[Fig. 4]

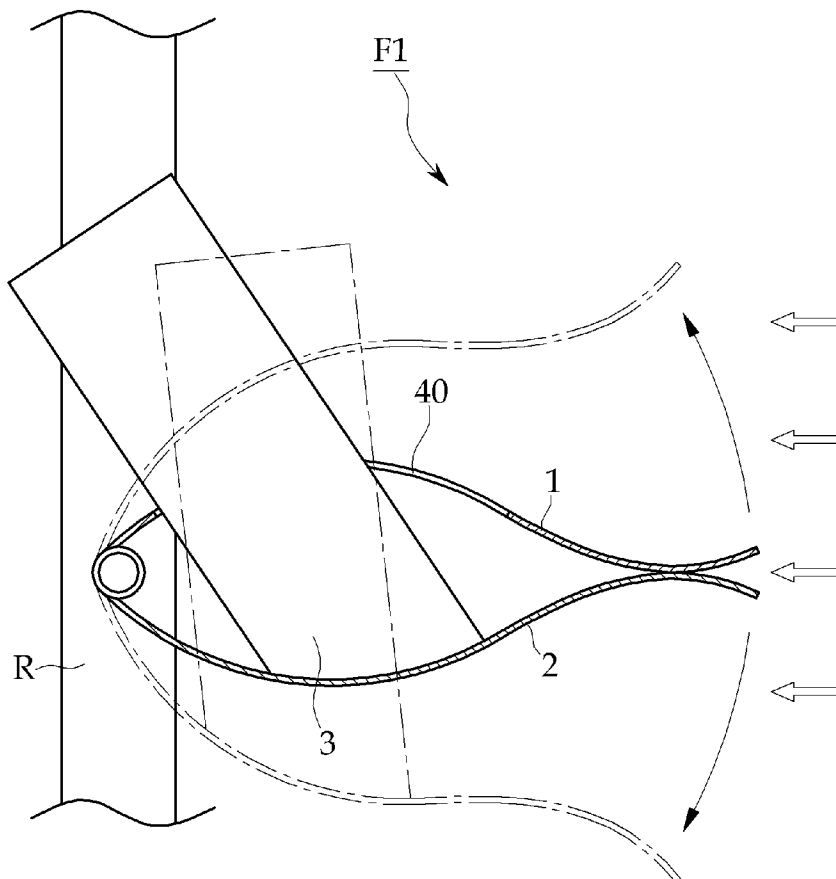

[Fig. 5]

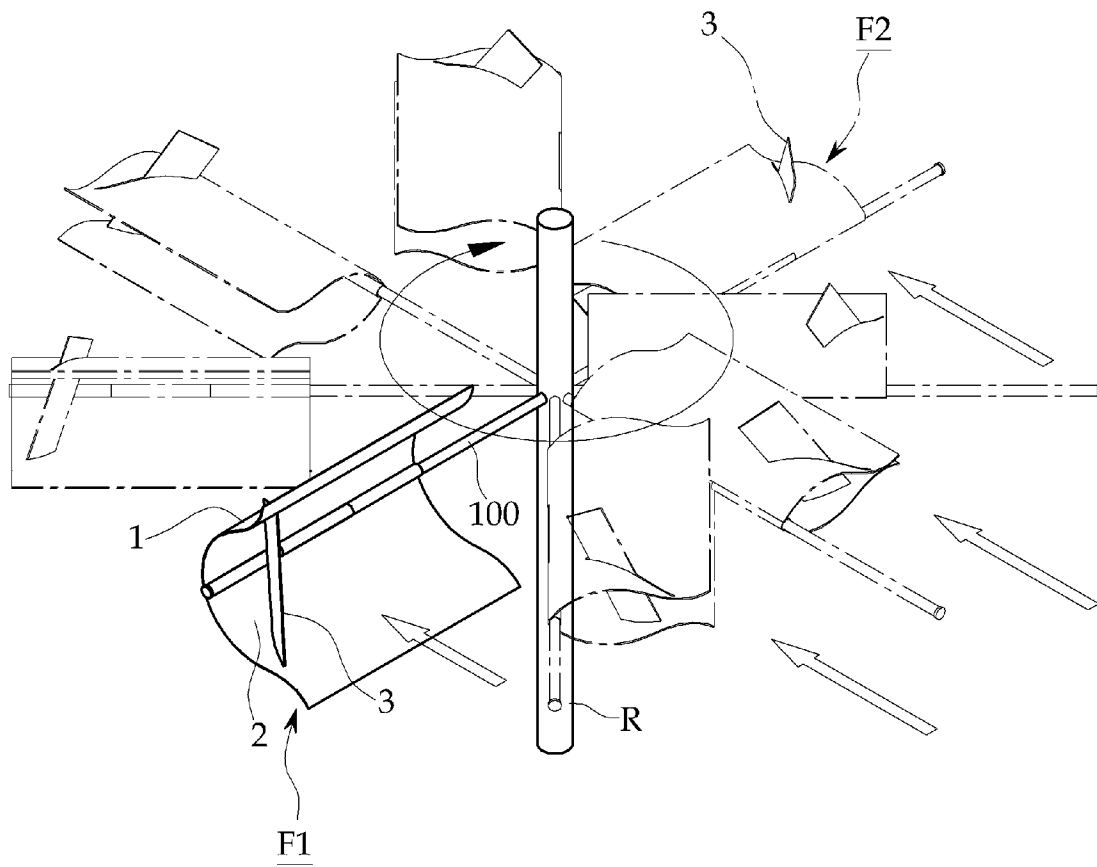

[Fig. 6]

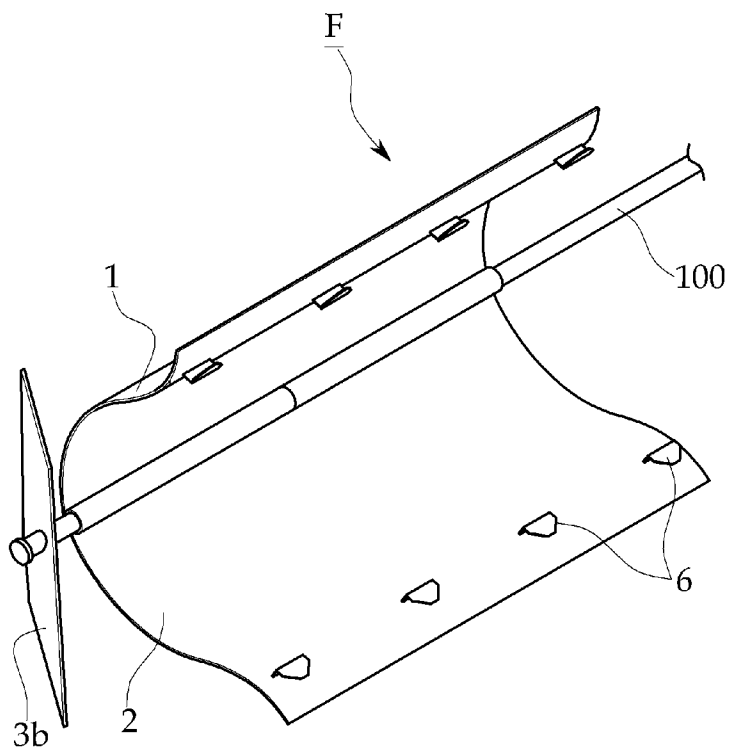

[Fig. 7]

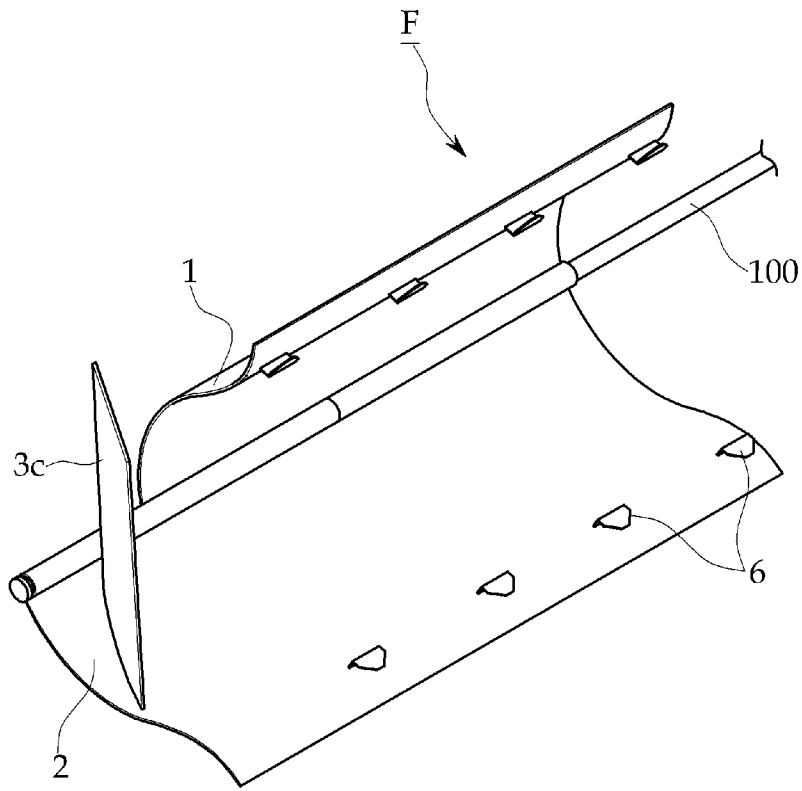

[Fig. 8]

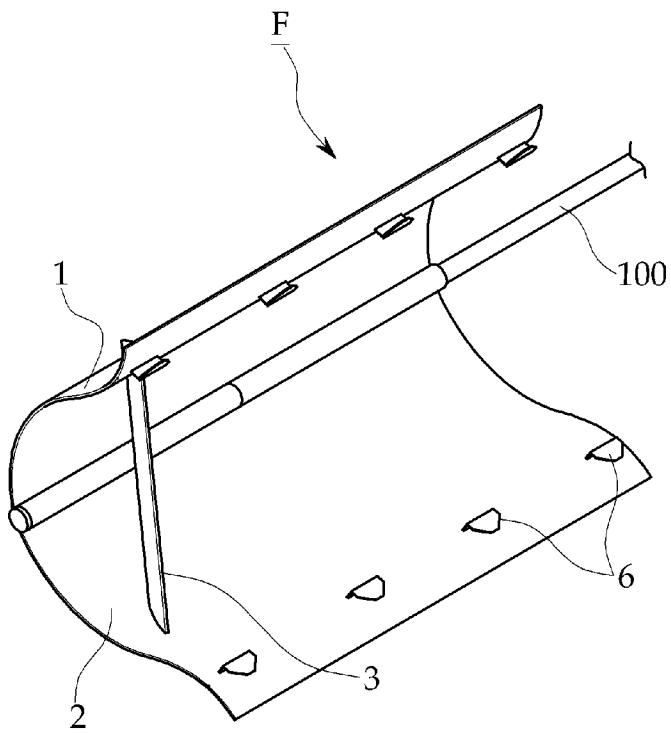

[Fig. 9]

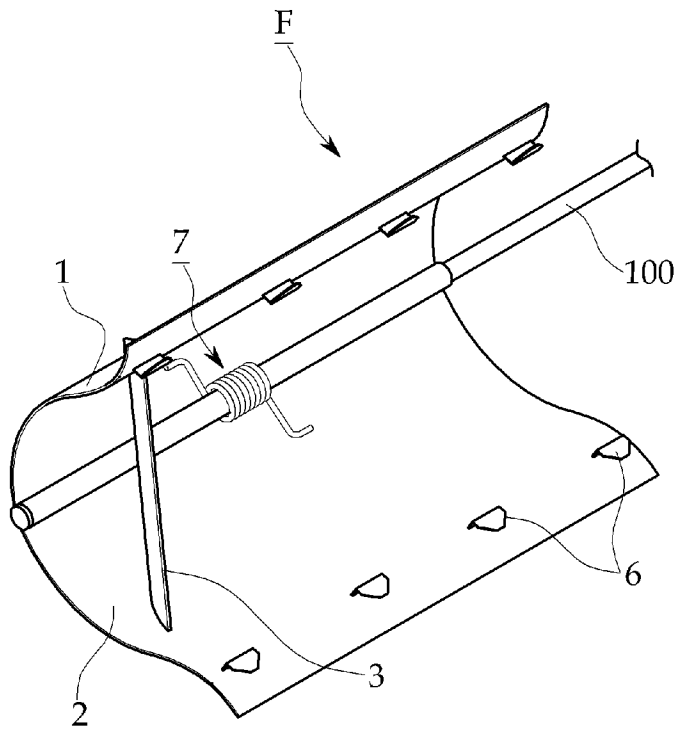

[Fig. 10]

