



US 20070208378A1

(19) **United States**

(12) **Patent Application Publication**
Bonutti et al.

(10) **Pub. No.: US 2007/0208378 A1**

(43) **Pub. Date: Sep. 6, 2007**

(54) **SUTURE ANCHOR AND METHODS FOR IMPLANTING SAME**

(76) Inventors: **Peter M. Bonutti**, Effingham, IL (US);
Mark V. Brillhart, Effingham, IL (US)

part of application No. 07/833,085, filed on Feb. 10, 1992, now abandoned, which is a division of application No. 07/545,919, filed on Jun. 28, 1990, now Pat. No. 5,163,960.

Publication Classification

Correspondence Address:

**PAUL D. BIANCO: FLEIT, KAIN, GIBBONS,
GUTMAN, BONGINI, & BIANCO P.L.
21355 EAST DIXIE HIGHWAY
SUITE 115
MIAMI, FL 33180 (US)**

(51) **Int. Cl.**
A61B 17/04 (2006.01)
(52) **U.S. Cl.** **606/232**

(21) Appl. No.: **11/747,304**

(22) Filed: **May 11, 2007**

(57) **ABSTRACT**

Related U.S. Application Data

(60) Continuation of application No. 10/295,127, filed on Nov. 15, 2002, now Pat. No. 7,217,290, which is a continuation of application No. 09/737,380, filed on Dec. 15, 2000, now Pat. No. 6,503,267, which is a continuation of application No. 09/362,279, filed on Jul. 27, 1999, now Pat. No. 6,203,565, which is a continuation of application No. 09/267,555, filed on Mar. 12, 1999, now Pat. No. 6,059,817, which is a division of application No. 09/019,511, filed on Feb. 5, 1998, now Pat. No. 5,928,267, which is a division of application No. 08/782,595, filed on Jan. 13, 1997, now Pat. No. 5,735,875, which is a division of application No. 08/453,631, filed on May 30, 1995, now Pat. No. 5,593,425, which is a continuation-in-

Surgical devices such as implants or suture fastenings are assembled from a plurality of discrete components, one of which components includes a heat bondable plastic material for bonding the components together. At least two components are bonded to each other by the applying heat to the heat bondable plastic material of one component. The heat bondable plastic material is preferably a polymeric or composite material suitable for surgical applications and implantation in humans, and may be a biodegradable material. A laser may be used as the heat source. The present invention is advantageously embodied in heat bonded fastenings for sutures or K-wires, in which a variety of different suture anchors are usable, including expandable distal suture anchors. Other embodiments include a metal bone plate which is held to bone by a metal bone screw and a nut of bondable material bonded to the plate to secure the connection; a piece of bondable material bonded to a metal prosthesis to custom fit the prosthesis; and a surgical implant custom formed by bonding together a plurality of discrete elements one or more of which is bondable.

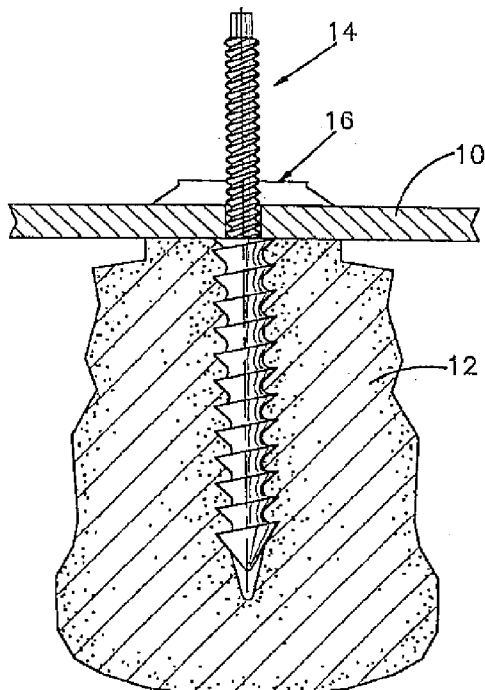

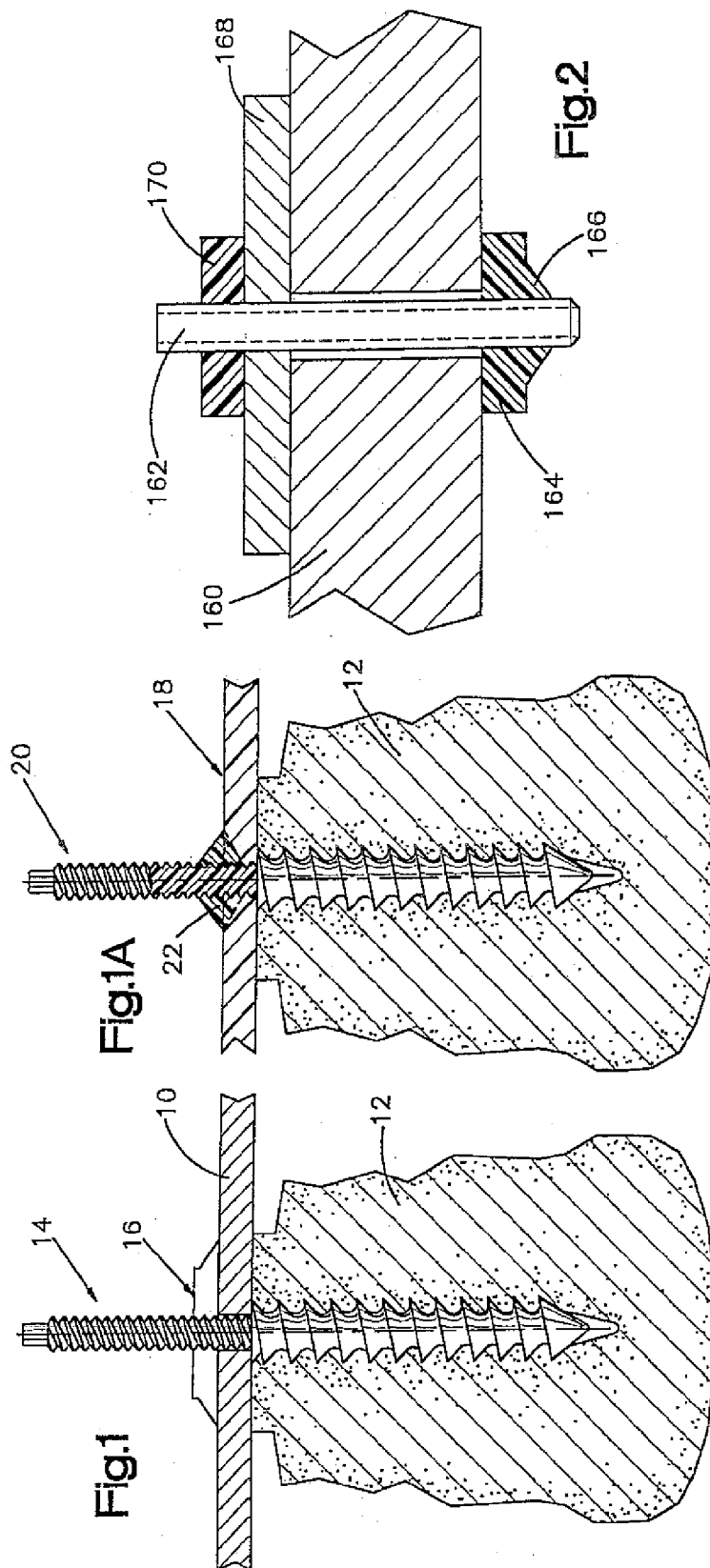

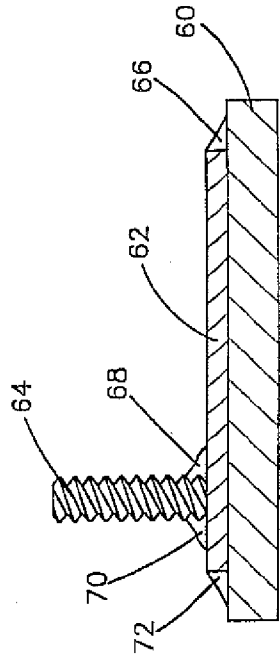
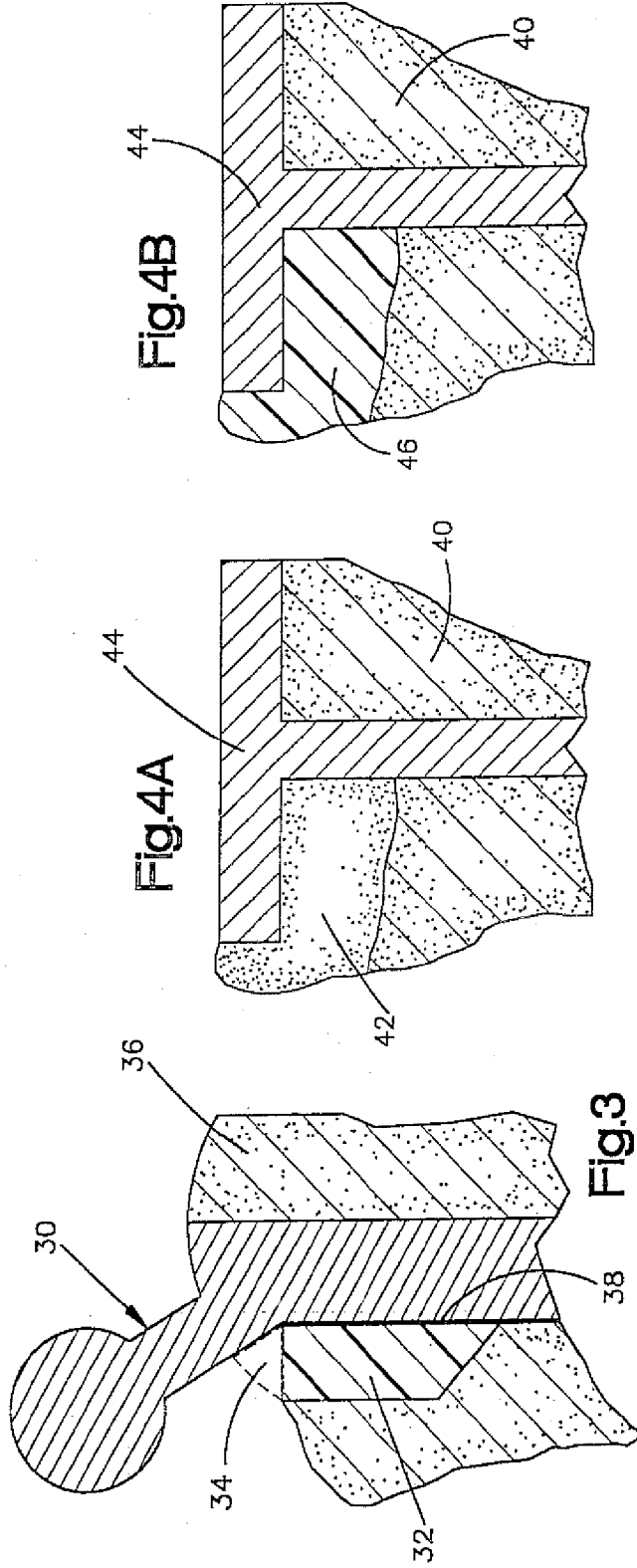

Fig. 5

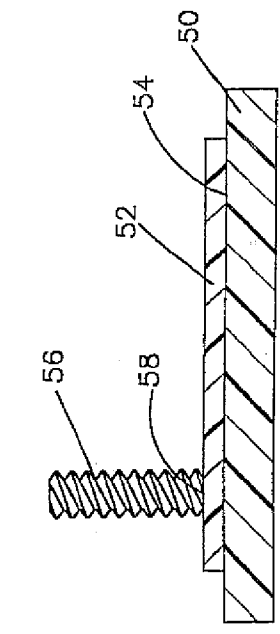
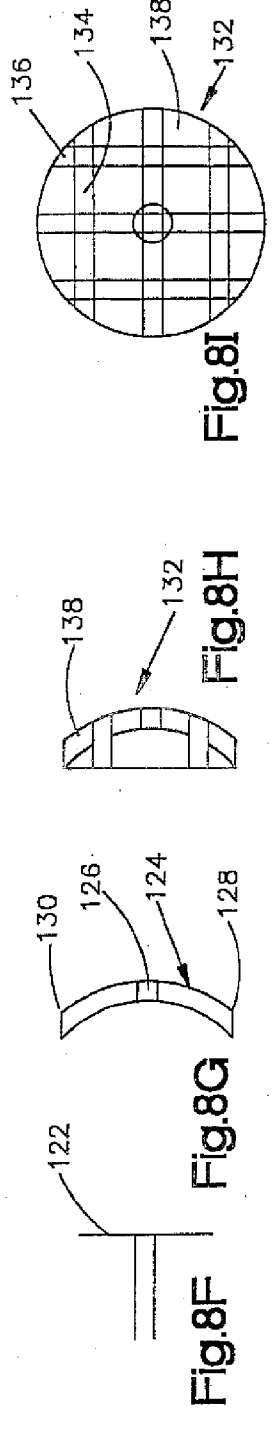
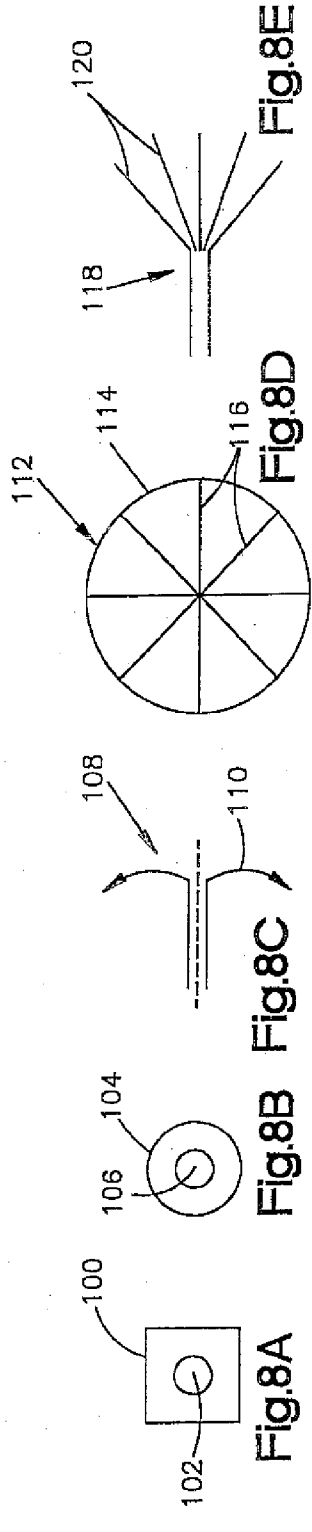
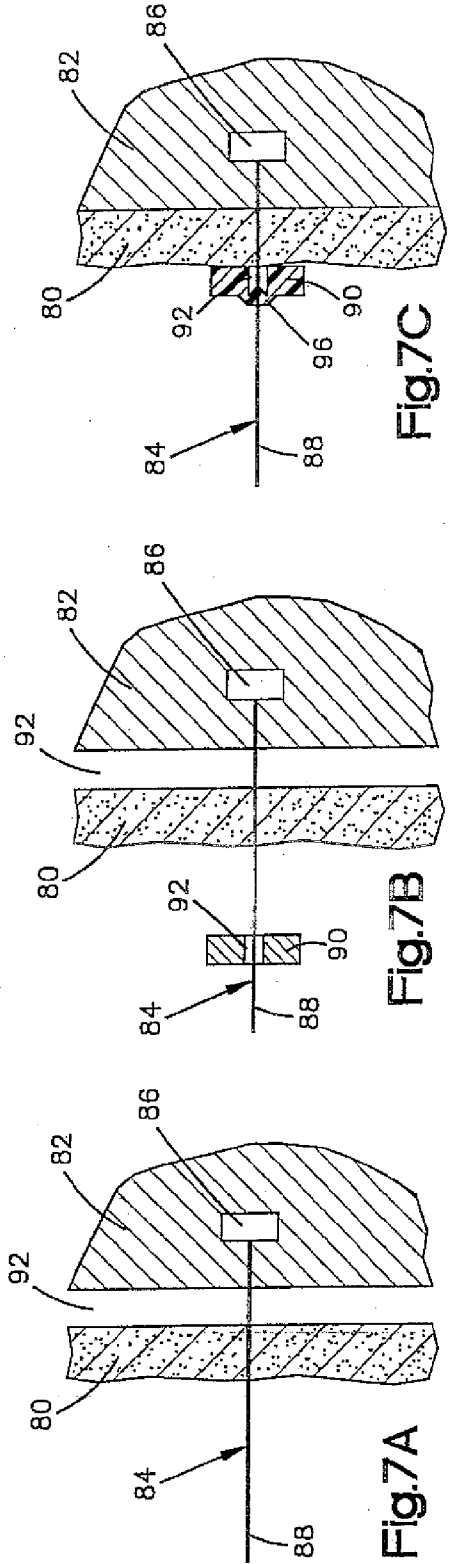
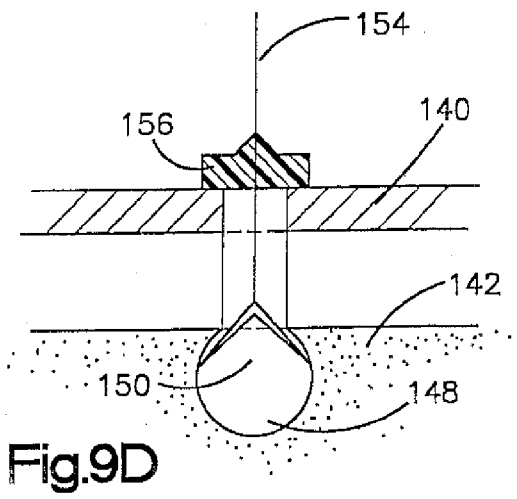
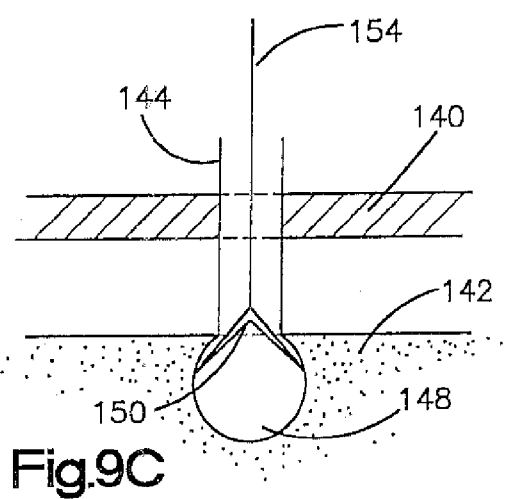
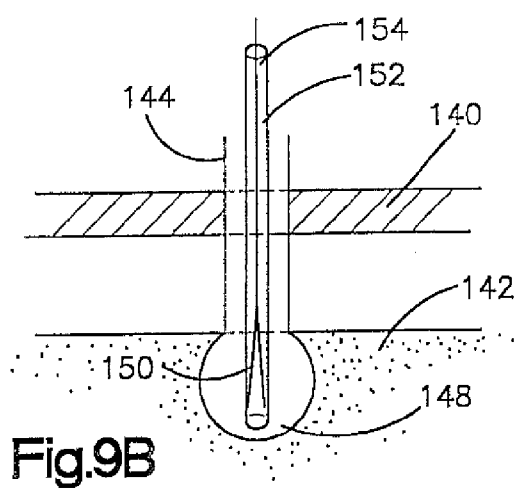
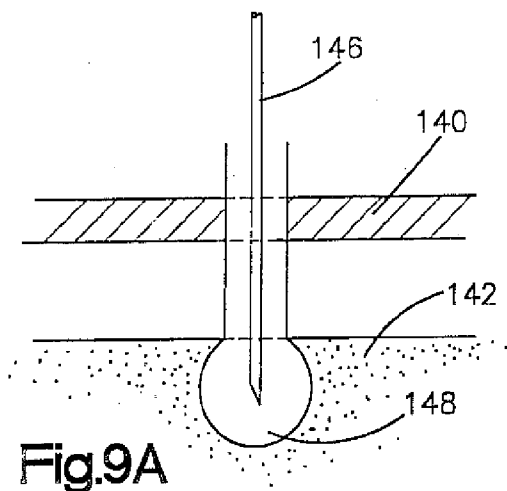

Fig. 6





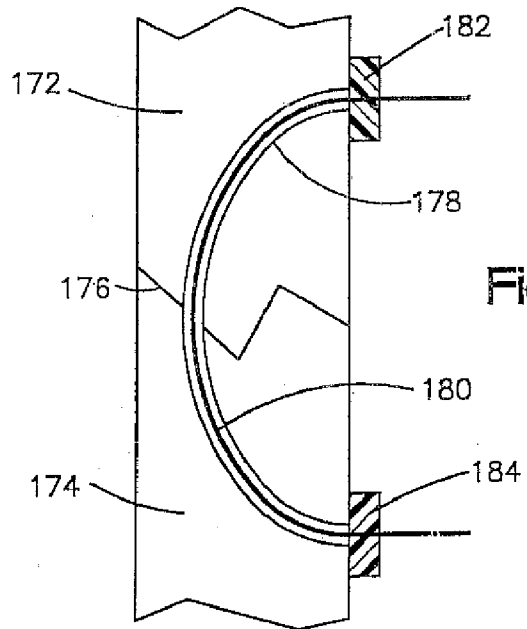

Fig.10

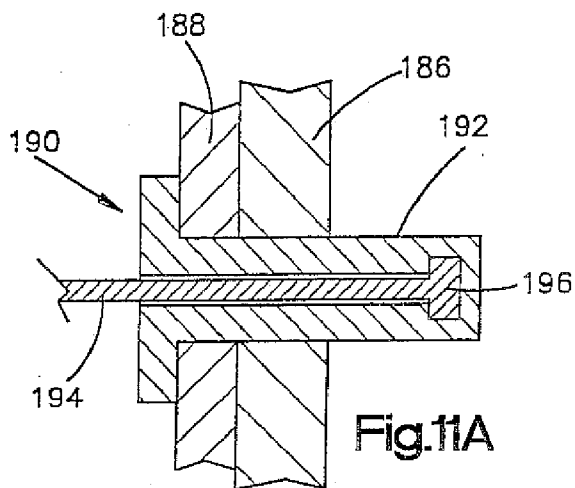

Fig.11A

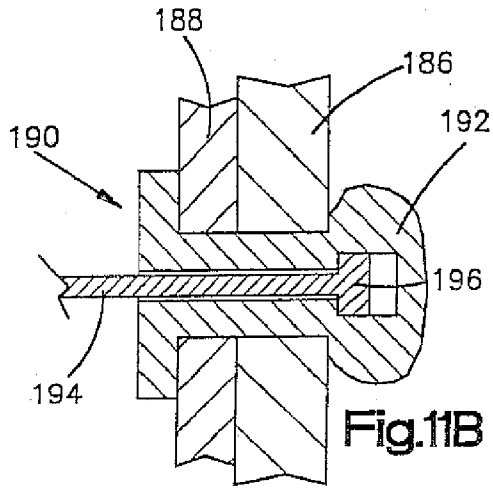

Fig.11B

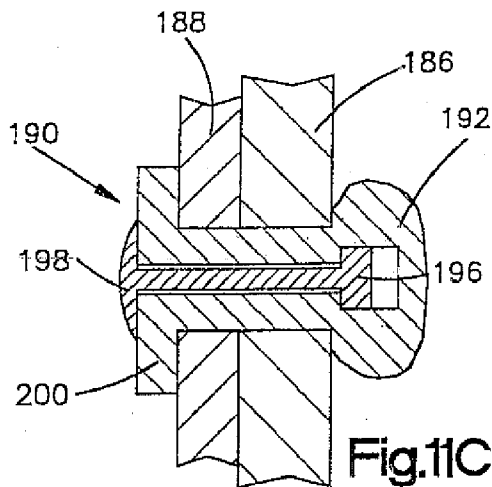

Fig.11C

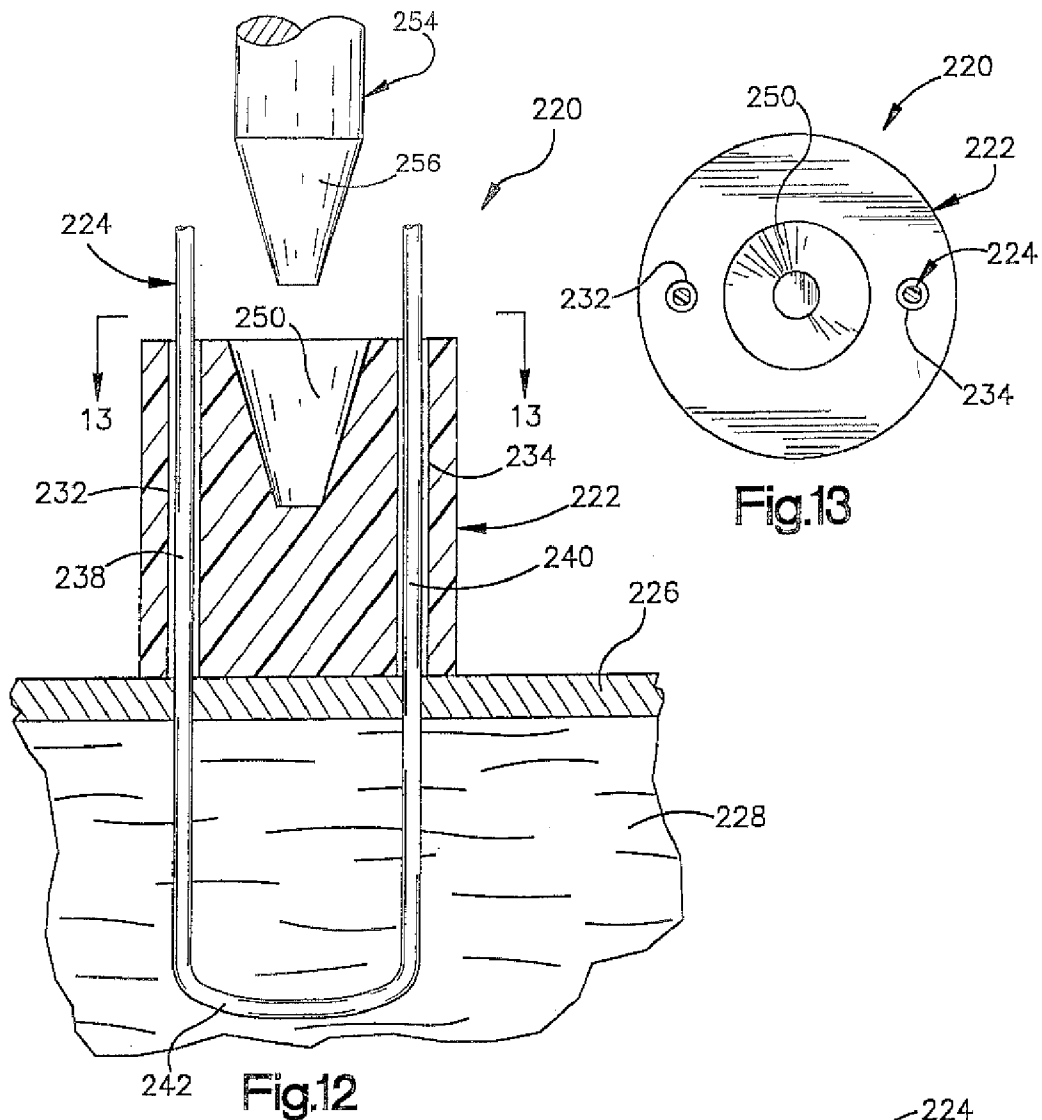

Fig.13

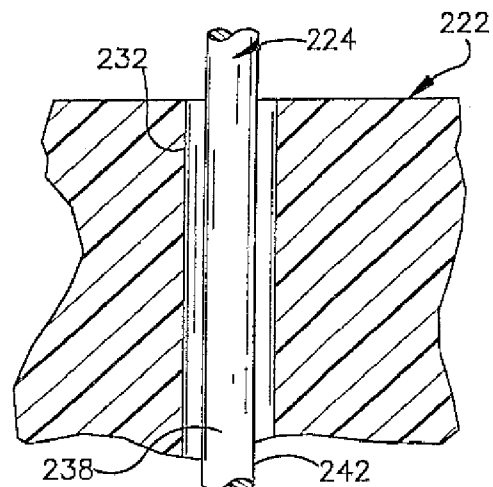

Fig.14

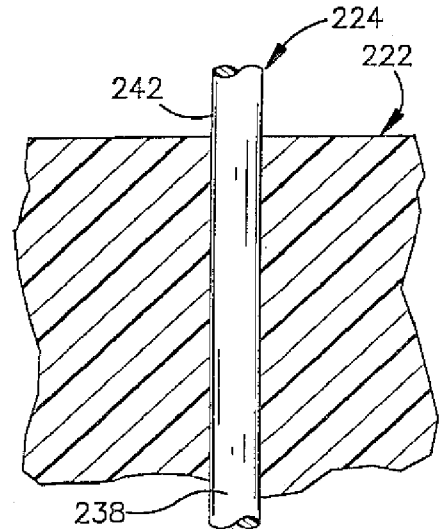

Fig.15

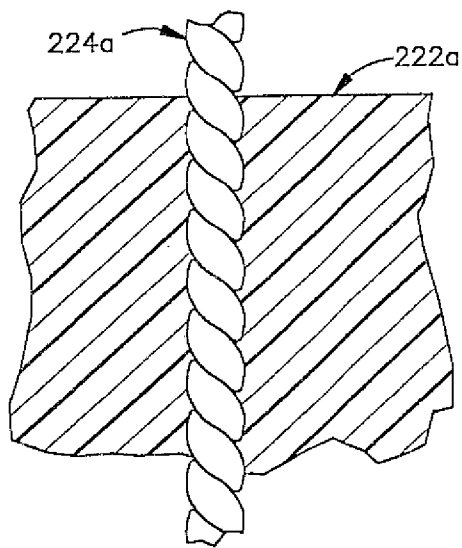

Fig.16

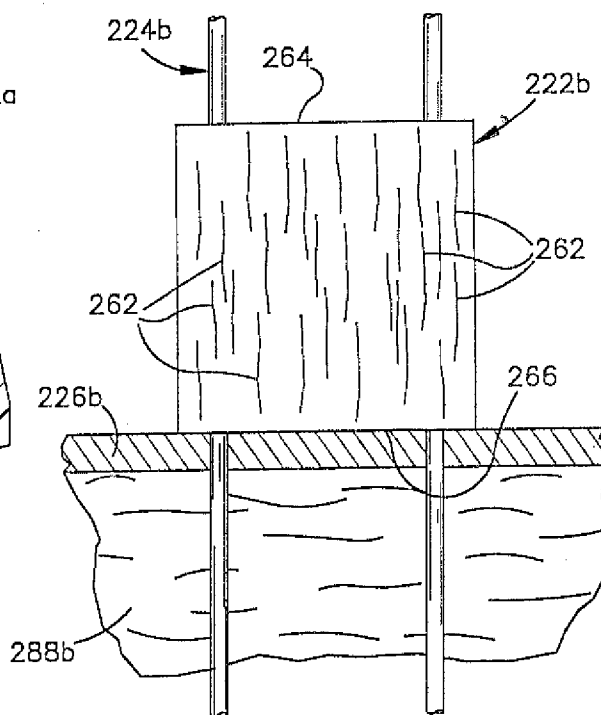

Fig.17

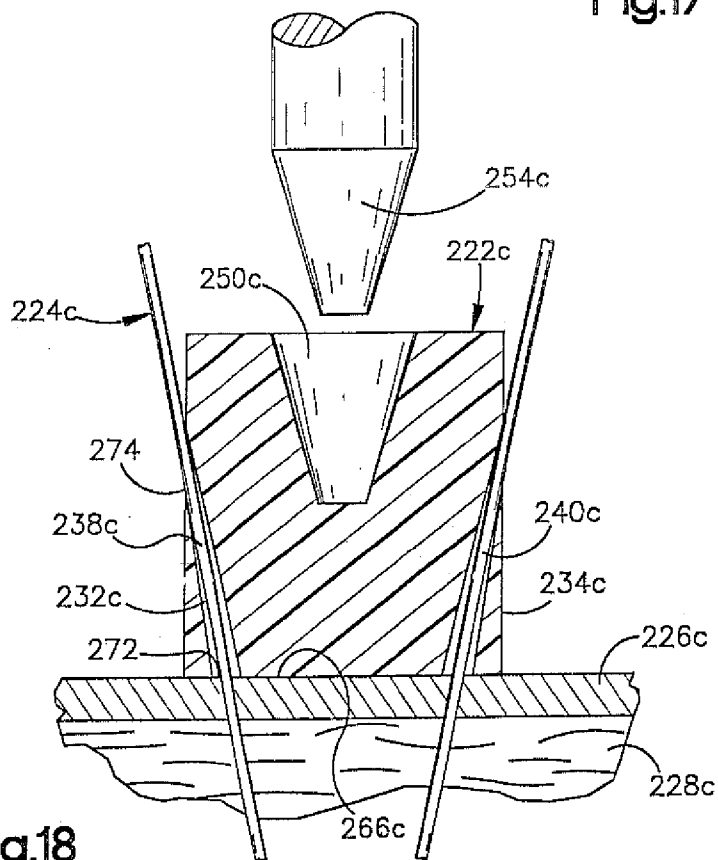

Fig.18

SUTURE ANCHOR AND METHODS FOR IMPLANTING SAME

CROSS-REFERENCE TO RELATED APPLICATIONS

[0001] This application is a continuation of U.S. patent application Ser. No. 10/295,127, filed Nov. 15, 2002, which in turn is a continuation of U.S. patent application Ser. No. 09/737,380, filed Dec. 15, 2000 (now U.S. Pat. No. 6,503,267). The aforementioned application Ser. No. 09/737,380 is itself a continuation of U.S. patent application Ser. No. 09/362,279, filed Jul. 27, 1999 (now U.S. Pat. No. 6,203,565 B1). The aforementioned application Ser. No. 09/362,279 is itself a continuation of U.S. patent application Ser. No. 09/267,555, filed Mar. 12, 1999 (now U.S. Pat. No. 6,059,817). The aforementioned application Ser. No. 09/267,555 is itself a divisional U.S. patent application Ser. No. 09/019,511, filed Feb. 5, 1998 (now U.S. Pat. No. 5,928,267). The aforementioned application Ser. No. 09/019,511 is itself a divisional of U.S. patent application Ser. No. 08/782,595, filed Jan. 13, 1997 (now U.S. Pat. No. 5,735,875). The aforementioned application Ser. No. 08/782,595 is itself a divisional of U.S. patent application Ser. No. 08/453,631, filed May 30, 1995 (now U.S. Pat. No. 5,593,425). The aforementioned application Ser. No. 08/453,631 is itself continuation-in-part of U.S. patent application Ser. No. 07/833,085 filed Feb. 10, 1992 (now abandoned). The aforementioned application Ser. No. 07/833,085 is itself a divisional of U.S. patent application Ser. No. 07/545,919, filed Jun. 28, 1990 (now U.S. Pat. No. 5,163,960). The benefit of the earlier filing dates of the aforementioned applications is hereby claimed.

FIELD OF THE INVENTION

[0002] The present invention relates to surgical devices such as implants or suture fastenings.

BACKGROUND OF THE INVENTION

[0003] Mundell U.S. Pat. No. 4,506,681 shows the use of a prosthesis which includes a biodegradable thermoplastic material molded around electric resistance elements to allow for heating to soften to mold to a particular shape.

[0004] Polonsky U.S. Pat. No. 4,662,068 discloses cutting off most of the protruding ends of a plastic suture and heating them to secure the ends together.

[0005] Jacobs U.S. Pat. No. 4,750,492 shows crimping or clipping a biodegradable fastener or retainer on the end of a biodegradable suture.

[0006] The compound methyl methacrylate is an acrylic resin monomer which is sometimes used in surgery to fasten or grout implants of metal to bone, or hip or knee replacements to bone. It is usable only for bone to metal applications. Tissue reacts to it and in soft tissue it creates a fibrous scar. Further, it is not biodegradable.

SUMMARY OF THE INVENTION

[0007] The present invention includes an assembly for use in surgical applications in humans. The assembly may include two components, at least one of which comprises a heat bondable material. The first and second components are bond to each other by the application of heat to the heat

bondable material, to make the heat bondable material soften, become tacky, and bond to the other component.

[0008] If only one of the components comprises a heat bondable material, the application of heat to the heat bondable material of that component causes the heat bondable material to soften and bond to the other component.

[0009] If both of the components comprise a heat bondable material, the application of heat to the heat bondable material of the components causes the heat bondable material of at least one and preferably each component to soften and bond to the other component.

[0010] The assembly can also include a first component, a second component, and a third component separate from the first and second components and comprising a heat bondable material. The application of heat to the heat bondable material of the third component causes the heat bondable material to soften and bond to the first and second components to interconnect the first and second components.

[0011] The heat bondable material is preferably a polymeric or composite material suitable for surgical applications and implantations in humans, and may be a biodegradable material where such is called for by the application.

[0012] The present invention may advantageously be embodied in heat bonded fastenings for sutures or K-wires, in which a variety of different suture anchors are usable, including expandable distal suture anchors. Such suture fastenings are easier to form and stronger than conventional tied knots. Other examples of assemblies embodying the present invention may include a metal bone plate which is held to bone by a metal bone screw and a nut of bondable material bonded to the plate to secure the connection; a wedge of bondable material bonded to a metal prosthesis to custom flit the prosthesis; and a surgical implant custom formed by bonding together a plurality of discrete elements one or more of which is bondable. Such embodiments are further described below.

[0013] The present invention may also provide a method of suturing body tissue. A portion of a suture is inserted into an opening in a retainer formed of a plastic material. At least a portion of the retainer is heated to a temperature in a transition temperature range of the plastic material forming the retainer. The suture is maintained at a temperature below the transition temperature range of a plastic material forming the suture while the retainer is heated. The plastic material of the retainer flows around the plastic material of the suture. A bonding of the plastic material of the retainer to the plastic material of the suture is effected by cooling the plastic material of the retainer to a temperature below its transition temperature range. The foregoing steps are performed without significant deformation of the plastic material of the suture.

BRIEF DESCRIPTION OF THE DRAWINGS

[0014] Further features of the present invention will become apparent to those skilled in the art to which the present invention relates from reading the following specification with reference to the accompanying drawings, in which:

[0015] FIG. 1 is an illustration of a metal bone plate which is held to bone by a metal bone screw and a nut of bondable

material bonded to the plate to secure the connection in accordance with one of the features of the present invention;

[0016] FIG. 1A is an illustration of a bone plate of bondable material which is held to bone by a bone screw and nut both of bondable material and bonded to each other to secure the connection;

[0017] FIG. 2 illustrates the use of a bonded fastening in accordance with one of the features of the present invention to obtain increased holding power on a fastener extending through a bone;

[0018] FIG. 3 is an illustration of a wedge of bondable material bonded to a metal hip prosthesis to custom fit the prosthesis;

[0019] FIGS. 4A and 4B are illustrations of a wedge of bondable material bonded to a metal tibial prosthesis to custom fit the prosthesis;

[0020] FIG. 5 is an illustration of a surgical implant custom formed by bonding together a plurality of discrete bondable elements;

[0021] FIG. 6 is an illustration of the use of a third component of bondable material to custom form a surgical implant by bonding together a plurality of discrete elements;

[0022] FIGS. 7A-7C are illustrations of a bonded suture fastening in accordance with one of the features of the present invention;

[0023] FIGS. 8A-8I are schematic illustrations of a variety of different suture anchors usable in bonded suture fastenings;

[0024] FIGS. 9A-9D are illustrations of an expandable distal suture anchor usable in bonded suture fastenings;

[0025] FIG. 10 illustrates the use of a curved hole in tissue parts to be joined with bonded fastenings on either end of the joining element;

[0026] FIG. 11A-11C are illustrations of a bonded rivet in accordance with one of the features of the present invention;

[0027] FIG. 12 is a schematic sectional view illustrating the manner in which a suture is placed relative to body tissue and extends into openings in a retainer;

[0028] FIG. 13 is a plan view, taken generally along the line 13-13 of FIG. 12, further illustrating the construction of the retainer;

[0029] FIG. 14 is an enlarged fragmentary sectional view of a portion of FIG. 13;

[0030] FIG. 15 is an enlarged fragmentary sectional view, generally similar to FIG. 14, illustrating the manner in which the retainer is bonded to the suture without significant deformation of the suture;

[0031] FIG. 16 is a fragmentary sectional view generally similar to FIG. 15, illustrating the manner in which the retainer is bonded to a braided suture;

[0032] FIG. 17 is a schematic illustration, generally similar to FIG. 12, schematically illustrating the orientation of polymer chains relative to the retainer; and

[0033] FIG. 18 is a fragmentary sectional view, generally similar to FIG. 12, illustrating a second embodiment of the retainer.

DETAILED DESCRIPTION OF THE INVENTION

[0034] In this application, the term “bondable” or “bondable material” is used to refer to any material, suitable for use in surgical applications, which can be softened and made flowable by the application of heat, and which, when softened, will become tacky and bond to other materials and will flow to fill available space. Thus, the material may be thermoplastic, but it may also exhibit tackiness or bonding ability when in its plastic form. Many materials suitable for surgery are made of or incorporate such heat bondable materials. Many biodegradables, polymers such as polyethylene, and composites fall in this class. They can be joined by heat bonding at reasonably low temperatures which can be applied in the operating room safely, unlike the very high temperatures needed to melt metal. Composite materials can include reinforced plastics, or polymers which are laminated or layered or reinforced with one or more other materials such as nylon, graphite fibers, Kevlar® fibers, stainless steel fibers, etc. Many sutures are made of polymers which are suitable for use herein. Selection of such material is within the ordinary skill of the art.

[0035] Various components of at least some embodiments of the invention are formed of a plastic material. A plastic material is a material which contains one or more polymers and which may also contain other materials such as fillers, solvents, plasticizers, lubricants, accelerators, dyes, etc. An interconnection or bond between plastic materials occurs as a result of molecular attraction (adhesion) and/or mechanical force resulting from shrinking of the plastic material. A transition temperature range of the plastic material is a temperature range at which the plastic material changes from a solid condition in which it has a fixed form to a viscous condition in which the material readily flows and is soft enough to be molded.

[0036] Any suitable heat generating apparatus can be used to heat and soften or spot weld the material, such as a hot air gun, a small welding or soldering gun, or a Bovie tip. Also usable are lasers, which are commonly provided in operating rooms. Lasers are especially desirable because they are precise and controlled in their application, can generate sufficient heat very quickly, and cause less thermal necrosis because there is less misdirected heat. The heating operation can be done pre-operatively to form an assembly; can be done outside the body but in the operating room to customize implants at the time of surgery; or can be done during surgery, in the body, when the bond is needed within the human body.

First Embodiment

[0037] FIGS. 1 and 2 illustrate heat bonded assemblies including existing surgical objects such as plates, screws, etc. In FIG. 1, a bone plate 10 is secured to bone material 12 by a bone screw 14. The bone plate 10 and the bone screw 14 are both made of metal. Ordinarily, the bone screw 14 would be secured to the bone plate 10 by a metal nut threaded onto the bone screw 14 and run up adjacent the bone plate 10. However, such a connection can loosen and

thus destroy the integrity of the assembly. Accordingly, in accordance with the present invention, a nut **16** is provided which is made of or includes a bondable material. The nut **16** is threaded on the bone screw **14** into abutting engagement with the bone plate **10**. Then, the bondable material of the nut **16** is heated and softened to flow about the joint between the nut **16** and the bone plate **10**, to bond the nut **16** to the bone plate **10**. The nut **16** can also be bond to the bone screw **14** if desired for a stronger connection.

[0038] FIG. 1A illustrates an assembly similar to FIG. 1 in which a bone plate **18** and a bone screw **20** both made of or including bondable material are provided. The nut **16** (FIG. 1) is not used. Instead, the bone screw **20** is bonded directly to the bone plate **18** at an area **22**.

[0039] As noted, ordinarily a bone plate is held to bone via a threaded fastener such as the bone screw **14** or **20** in FIG. 1. However, the bone is alive and is constantly remodeling the threads on the bone screw. As this happens, the fastener loses its purchase or holding power in the bone, and the screw can pull loose. Accordingly, it would be desirable to obtain more purchase by a different kind of fastener.

[0040] FIG. 2 illustrates the use of a bonded fastening in accordance with the present invention to obtain increased holding power. The fastener extends completely through a tissue mass such as a bone **160**, for example to secure a plate in position against the bone. An elongate fastener **162**, which may be metal or may be made of or include a bondable material, is inserted through an opening in the bone **160**. A distal fastener **164** is secured to the distal end of the screw **162** by a plug of bonded material **166**. The plate **168** is then placed over the bone screw, and a proximal fastener **170** made of or including a bondable material is bonded to either or both of the screw **162** and the plate **168**. The elongate fastener **162** may optionally also be threaded in the portion engaging the bone **160**. The elongate fastener **162** may optionally also be threaded in the portion engaging the fastener **164** and/or the fastener **170**.

[0041] The bonded fastenings obtained thereby are stronger than is possible with either a threaded connection or a tied or crimped connection. Further, there is no reliance on a threaded connection between bone and fastener which will inevitably weaken over time. Also, bone screws are threaded and are always straight. The elongate fastener **162** need not be straight because it need not be threaded. Thus, it can be curved, or angled, as needed or desired to fit any particular application. In combination with the bonded connection of the fasteners at the ends of the elongate fastener, such a structure is a vast improvement over a typical metal threaded fastener.

[0042] FIGS. 3 and 4 illustrate surgical assemblies in which an existing surgical prosthesis or implant has been modified to better fit the particular application. Such prostheses or implants come from a manufacturer in only a limited range of sizes and shapes. However, the particular bone into which a prosthesis or implant is to be inserted may have defects or size discrepancies which would make it impossible to obtain a good fit with even the closest fitting prosthesis or implant.

[0043] In accordance with one of the features of the invention, the shape and size of a prosthesis or implant are modified to fit a particular bone. A femoral prosthesis **30**

illustrated in FIG. 3 has been modified with the addition of a wedge **32** including heat bondable material in order to better fit a gap **34** in the bone **36**. The wedge **32** is custom shaped to fit the gap **34** exactly. The connection **38** between the wedge **32** and the prosthesis **30** is secured by heating and softening the wedge **32** so that the material of the wedge **32** adheres or bonds to the prosthesis **30**. The assembly of the heat bondable wedge **32** and the femoral prosthesis **30** fits the femur **36** much more properly than would the prosthesis alone. This assembly can easily be made right in the operating room at the time of the joint reduction, allowing the surgeon to customize or equilibrate at the time of surgery.

[0044] Similarly, in FIG. 4, a tibia **40** is shown to have an area of defect **42** which makes it impossible to properly fit a tibial component **44**. Accordingly, as seen in FIG. 4B, an element **46** including a heat bondable material is shaped with heat as by a laser in the operating room to fit the defect **42**. The element **46** is then bonded to the tibial component **44** prior to placement thereof in the bone **40**. The assembly of the tibial component **40** and the element **46** provides a proper fit in the tibia **40**. There is no other suitable way of matching the requirements of bone and joint in the operating room.

[0045] The bone components shown in FIGS. 3 and 4 are only an illustration of the many kinds of objects which can be used to form assemblies embodying the present invention. It can thus be seen, as illustrated in FIGS. 3 and 4, that the present invention gives the surgeon the ability to immediately modify the shape and size of almost any existing surgical part including a prosthesis, in order to better fit the particular application for use in the body. This is accomplished by heat bonding a piece of bondable material onto the prosthesis, to make an assembly designed for the particular application. The piece can be custom shaped in the operating room to fit the application exactly by heating and bonding of a polymer or composite.

[0046] FIGS. 5 and 6 illustrate schematically some custom fabricated implants which can be constructed in accordance with the present invention. In FIG. 5, a relatively thick plate **50** is joined to a relatively thin plate **52**. Both the plate **50** and the plate **52** are made of or include a bondable material. The plates **50** and **52** are joined at the area of the joint **54** between them, by bonding in accordance with the present invention. A third element such as a stud **56** may be added, with bonding at the joint **58** therebetween. Thus, the surgeon has the ability to laminate pieces in surgery and does not have to rely on pre-made hardware.

[0047] It should be understood that the illustration in FIG. 5 of plates and a stud is not limiting, but is only illustrative of the almost limitless number of surgical devices which can be constructed in accordance with the present invention. Items such as rods, bars, plates, or any type of construct usable in medical/surgical applications object can be custom shaped or built up in accordance with the present invention. They can be made of polymers or composites which can easily be cut with a laser and also softened to custom fit. They can be made of or include a biodegradable material in those instances where it is desired that the material be replaced, over time, with natural tissue ingrowth. They can also include tissue ingrowth promoters, antibiotics, or other additives as desired.

[0048] Rather than having one or both of the components to be joined made of a bondable material, a third component can be used to join them, with the third component being made of or including a heat bondable material. The third component is non-flowable and non-adherent at room temperature before use. When it is softened by heating and applied to the first and second components, it bonds to both components to interconnect them. A laser is ideal for heating the interpositional bonding material because of the accuracy available with the laser. As an example, FIG. 6 illustrates an assembly similar to FIG. 5 in which a plate 60 and a plate 62 and a stud 64 are joined by the use of additional bonding material at locations 66, 68, 70, and 72. In this case, the plates 60 and 62 and the stud 64 need not be made of heat bondable materials.

[0049] For example, a total hip or knee replacement is possible using components bonded together by heat. If some or all of the parts are made of heat bondable material such as polymers or composites, an assembly as described herein can be produced simply by the application of heat to bond the parts together as desired. If the replacement does not fit the existing bone exactly, it can be customized at the time of surgery by cutting as with a laser, by adding as by bonding, or by heating to bond wedges or pieces to it.

[0050] It can be seen that the present invention also provides the capability for forming a custom-fit surgical implant for bonding to a bone or to a bone prosthesis which comprises a component at least partially formed of a heat-bondable material which has been custom-shaped by the application of heat to said heat-bondable material. In this instance, the aforementioned laser is most suitable for forming the implant. The lasers which are commonly found in operating rooms can cut, shape and otherwise form almost any suitable material used herein, including polymers, biodegradable materials, and even composites including reinforcing materials. The implant can include several components each having heat-bondable material, or several components only one of which includes a heat-bondable material, or it can be a single component which is custom made for a particular application. Such use of heat to form implants provides the surgeon with greatly extended capabilities in the operating room and does not limit him to preformed implants or prostheses.

Second Embodiment

[0051] It is difficult to tie a suture knot to itself or to slide it down through deep tissue in a limited working area (as in fiber optic surgery). Typically, the surgeon can often not work in a straight line but needs to use a suture loop (going through the tissue twice) to bring tissue together. Any such increase in the amount of tissue through which the suture must pass increases damage to tissue. Furthermore, mechanical tying or crimping of sutures or K-wires, especially of polymers or biodegradables which are generally smooth, does not produce connections which are as strong as desirable, and suture connections sometimes may come untied as a result.

[0052] In accordance with one of the features of the present invention, surgical connections for holding adjoining tissues together are secured by melting a fastener or anchor on the end of a suture, rather than by tying or by clipping the anchor on the end of the suture. (The term

“suture” is used herein to refer to a suture, a K-wire, or any similar surgical connector.) The anchor is pushed over the free end of the suture down to the tissue, drawing the tissues together. Either the anchor alone or the anchor and the suture are melted together to lock them into position.

[0053] With the fasteners of the present invention, therefore, a surgeon has more control since he can apply more pressure to push the tissues together and it is easier to appose the tissues; the tension on the repaired tissues is more controllable, predictable, and reproducible; and the fasteners can be used in a smaller working space. Further, a melted anchor provides a stronger bond than the mechanical interlock of a suture knot, because it will not unravel or come apart as a surgical knot may. It takes less time to fasten than it does to tie a suitable knot. There is improved contact between the tissues being joined because of the better suture connection. The straight line suture fastening also avoids buckling of the tissue edges caused by force vectors not extending in the direction of the suture.

[0054] Since he only needs one free suture end to make a secure connection, the surgeon does not need to use a suture loop to bring tissue together, but can work in a straight line. This lessens damage to tissue because a straight line connection is easier to obtain than a loop in a limited space. Also, it improves tissue apposition and approximation when a straight line fastening is pulled together rather than a loop which tends to buckle or pucker tissue at the edges because of the force vectors not directed along the length of the suture.

[0055] The fasteners can be used for the fixation of soft tissue, tendon, ligament, meniscus, muscle, fascia, vessels, nerves or bones to each other. They can be used, for example, to hold a rotator cuff to bone, or to join fracture fragments of bone to bone. The anchors can be custom molded, specially made at the time of surgery (or preoperatively) to conform exactly to the tissue or bone application.

[0056] One anchor is secured to the distal end of the suture. (Alternatively, it may be preformed or connected on the suture in any known manner of connection.) The suture is then positioned in the tissues to be joined, a second anchor is slid over the free end, pulled down to close the gap, and melt it in place.

[0057] As illustrated in FIG. 7, two pieces of tissue 80 and 82 are to be joined using a suture 84. A distal anchor 86 is located on the end of the suture 84. The suture is then inserted through the tissues 82 and 80 so that a free end 88 of the suture 84 protrudes at the proximal end. A fastener 90 having an opening 92 therein is slid over the wire 84 and pulled down tight as shown in FIG. 7C to close the gap 94 between the tissues 80 and 82.

[0058] The fastener 90 is made of a heat bondable plastic material. (The suture can also be made of heat bondable plastic material which is bonded to secure the connection.) The fastener 90 is then bonded at an area 96 to the protruding free end 88 of the suture 84. In FIG. 7C, it can be seen that the fastener 90 is bonded to the suture 84 without significant deformation of the suture. Alternatively, the fastener 90 can be bonded along the length of the opening 92 to the suture 84. The protruding end of the suture 84 is then cut off. Applicant has found through testing that while a simple mechanical connection such as a knot or a crimped connec-

tor is not strong enough to hold in some circumstances, the bonded connection illustrated in FIG. 7 overcomes this difficulty and will hold.

[0059] FIG. 8 illustrates a few of the many fasteners which can be used in accordance with the present invention. FIG. 8A shows a simple square fastener 100 having a suture receiving opening 102 therein. The fastener 104 is round and has an opening 106 therein. The fastener 108 shown in FIG. 8C includes a plurality of barbs 110 for better gripping in the tissue against which it engages. The fastener 112 shown in FIG. 8 is umbrella-like in shape, having an outer rib 114 and a plurality of radially extending ribs 116.

[0060] The fastener 118 shown in FIG. 8E is filamentous, having a plurality of protruding filaments 120. The fastener 122 shown in FIG. 8F is a T-snap. The fastener 124 shown in FIG. 5G is curved or cupped about the opening 126 so that its ends 128 and 130 will flatten as pressure is applied upon drawing tight the suture. The fastener 132 shown in FIGS. 5H and 5I is reinforced with transverse ribs 134 and longitudinal ribs 136 for better strength. The ribs 134 and 136 protrude axially from the main body 138 of the fastener. Finally, any anchor or fastener can be specially made, that is, custom molded at the time of the surgery or preoperatively to conform exactly to the tissue against which it will be abutting.

[0061] FIG. 9 illustrates the use of an expandable distal suture anchor for bonded suture fastenings in accordance with the present invention. In particular, FIG. 9 illustrates the use of a bonded assembly to secure a tendon 140 to bone 142. To make the assembly, initially, a cannula or sleeve 144 is inserted through the tendon to the bone. A gouge 146 is then used to gouge out an opening 148 in the soft cancellous tissue under the cortical bone. An expandable anchor 150, confined in a sleeve 152 and having a suture 154 extending proximally from the sleeve 152, is inserted through the cannula 144 into the opening 148 in the bone. The sleeve 152 is then withdrawn, allowing the anchor 150 to expand within the opening 148, blocking removal of the suture.

[0062] A fastener 156 made of or including a bondable plastic material is then slid distally over the suture 154 into engagement with the tendon 140, and then further, pushing the tendon 140 into engagement with the bone 142. The anchor 156 is then bonded to the suture 154, providing a connection which is stronger than that of any tied knot. In FIG. 9D, it can be seen that the fastener 156 is bonded to the suture 154 without significant deformation of the suture. In a similar manner, an expandable anchor as illustrated herein can be used with a bonded fastening in any application in which the anchor must be placed in a blind location. This method can work also especially well with a barbed or umbrella-like anchor as illustrated in FIG. 8C or 8D.

[0063] FIG. 10 illustrates the use of bonded fastenings in accordance with the present invention in conjunction with a curved opening in tissue parts to be joined. Illustrated in FIG. 10 are two portions 172 and 174 of a fractured bone with their ends abutting at a joint 176. It is possible to secure together the bone ends with a suture which extends axially through the fractured ends of the bone, while accessing the joint only from one side of the bone. A curved opening 178 is drilled through the first bone part 172 and the second bone part 174, beginning at the proximal end of the first bone part 172, extending through the joint 176, and exiting at the

proximal face of the second bone part 174. A suture 180 is then passed through the opening 178. A first fastener 182 made of or including a bondable plastic material is then bonded onto the protruding end of the suture 180. The suture is then pulled tight, and a second fastener 184 also made of or including a bondable material is pulled down tight against the proximal face of the second bone part 174 and bonded by heating in location to the suture 180. In FIG. 10, it can be seen that the fasteners 182 and 184 are bonded to the suture 180 without significant deformation of the suture.

[0064] FIG. 11 illustrates the use of a bonded fastening in accordance with a feature of the present invention in conjunction with a rivet type fastening. To secure together two adjoining masses 186 and 188, a sleeve 190 is inserted through an opening in the tissues until the distal end 192 of the sleeve projects behind the tissue 186. A mandrel 194 in the sleeve 190 has a headed portion 196 at its distal end 192. The mandrel 194 is then pulled outwardly, while the sleeve 190 is held in place, spreading the distal end 192 of the sleeve to lock the sleeve in place behind tissue 186. The protruding end of the mandrel 194 is then cut off flush with and bonded by heating as at 198 to the head end 200 of the sleeve. This type of bonded connection can be used in various applications where the surgeon is connecting two tissue masses with access only from one side thereof.

[0065] The present invention also is embodied in a method of making an assembly for use in surgical applications in humans. The method comprises the steps of providing a first component which comprises a heat bondable plastic material; providing a second component; and bonding the first and second components to each other by the application of heat to the heat bondable material to make the heat bondable material bond to the other component. In the method, the second component may be a surgical prosthesis or implant, or it may be a bone plate or bone screw. The heat bondable plastic material used in the method may be a polymer, a composite, or a biodegradable material.

[0066] The present invention also is embodied in a method of fastening a suture or K-wire to hold together adjoining tissue masses in a human surgical application. The method comprises the steps of inserting the suture into the desired location in the tissue masses, placing in position on the suture a suture fastener, and bonding the suture to the fastener by applying heat to one or both of the fastener and the suture to bond the fastener to the suture. Further, the fastener may be mechanically crimped first and then heat bonded to provide the benefits of both types of fastenings.

[0067] The present invention is also embodied in a kit of components for forming an assembly by heat bonding for use in surgical applications in humans and incorporating at least one heat bondable material. The kit comprises a first component and a second component comprising a heat bondable material, with the first and second components bondable to each other upon the application of heat to the second component to make the heat bondable material of the second component bond to the first component. The kit may further include heat generating means for generating heat to bond said first component to said second component. The components and the heat generating means are as described above with respect to the assemblies.

Method and Apparatus for Suturing Body Tissue

[0068] An apparatus 220 for use in suturing human body tissue (FIG. 12) includes a retainer or crimp 222 and a suture

224. The suture **224** extends through a layer **226** of skin into body tissue **228** disposed beneath the skin. Although the suture **224** as been illustrated in FIG. **12** in association with soft body tissue **226** and **228**, it is contemplated that the suture **224** could be used in association with relatively hard body tissue, such as bone. The suture **224** may be placed in many different locations in the human body for many different purposes. For example the suture **224** may be used with a suture anchor in the manner disclosed in U.S. Pat. No. 5,403,348 issued Apr. 4, 1995 and entitled Suture Anchor.

[**0069**] The retainer **222** is formed of a plastic material. The suture **224** is also formed of a plastic material. The retainer **222** is bonded to the suture **224** without significant deformation of the suture. This enables the retainer **222** to securely hold the suture relative to the body tissue **226** and **228** without impairing the strength of the suture. Although the retainer **222** has been shown in FIG. **12** as being connected with opposite end portions of a single suture **224**, the retainer could be connected with end portions of two separate sutures.

[**0070**] In the illustrated embodiment of the invention, the retainer **222** has a generally cylindrical configuration (FIGS. **12** and **13**). The retainer **222** has a pair of linear cylindrical passages **232** and **234** through which the suture **224** extends. Thus, a portion **238** of the suture **224** extends through the passage or opening **232**. A portion **240** of the suture extends through the passage or opening **234** (FIG. **12**).

[**0071**] In the suture arrangement illustrated in FIG. **12**, a connector portion **242** of the suture **224** interconnects the two portions **238** and **240**. If desired, the connector portion **242** of the suture **224** could extend through a suture anchor. It is contemplated that the connector portion **242** of the suture **224** could extend around ligaments or other human body tissue. It is contemplated that the retainer **222** could be used to interconnect sutures in a series of sutures.

[**0072**] After the two portions **238** and **240** of the suture **224** have been inserted into the passages or opening **232** and **234** in the retainer **222**, the retainer and suture are interconnected to hold the suture against movement relative to the body tissue. To interconnect the retainer and the portion **238** of the suture **224**, the plastic material of the retainer **222** is heated to a temperature in a transition temperature range of the plastic material of the retainer **222**. The plastic material of the suture **224** is maintained at a temperature below the transition temperature range of the plastic material forming the suture.

[**0073**] Thus, in the specific embodiment of the invention illustrated in FIGS. **12-15**, the plastic material of the suture **224** has a transition temperature range which is above 190° Celsius. The specific retainer **222** illustrated in FIGS. **12-15** has a transition temperature range which is below 190° Celsius. However, it should be understood that at least a portion of or even the entire transition temperature range for the suture **224** could be coextensive with the transition temperature range for the retainer **222**. In fact, the transition temperature range of the suture could extend below the transition temperature range of the retainer. However, it is believed that it will be advantageous to have a higher transition temperature range for the suture than for the retainer.

[**0074**] Once the plastic material of the retainer **222** has been heated to a temperature in the transition temperature

range for the plastic material of the retainer, the plastic material of the retainer flows around the plastic material of the suture **224**. This occurs while the plastic material of the suture **224** is maintained at a temperature below the transition temperature range of the plastic material of the suture. Thus, the portion of the plastic material of the retainer **222** forming the passage **232** (FIG. **14**) is heated to a temperature in its transition temperature range. The plastic material of the retainer **222** then flows inwardly around the portion **238** of the suture **224** to eliminate the passage **232** (FIG. **15**).

[**0075**] As this occurs, the portion **238** of the suture **224** maintains its original configuration and is not significantly deformed. Thus, an outer side surface **242** of the suture **224** has the same cylindrical configuration along the length of the suture both in the areas where the outer side surface of the suture is exposed to the heated material of the retainer **224** and in the areas where the suture is not exposed to the heated material of the retainer **222**. By maintaining the configuration of the portion **238** of the suture exposed to the heated material of the retainer **222** constant, the suture **224** is not weakened in the areas where it is exposed to the heated material of the retainer.

[**0076**] After the material of the retainer **222** has been heated and flows around the portions **238** and **240** of the suture **224**, in the manner illustrated schematically for the portion **238** of the suture in FIG. **15**, the heated plastic material of the retainer is cooled to a temperature below the transition temperature range of the plastic material of the retainer. As the plastic material of the retainer is cooled to a temperature below its transition temperature range, the plastic material of the retainer bonds to the suture **224**. Thus, the plastic material of the retainer **222** bonds to the portion **238** of the suture **224** and bonds to the portion **240** of the suture.

[**0077**] As the plastic material of the retainer **222** is cooled and bonds to the outer side surface **242** of the suture **224**, a secure interconnection occurs between the material of the retainer **222** and the material of the suture **224** at the portions **238** and **240** of the suture. The interconnection between the material of the retainer **222** and the material of the portion **238** and **240** of the suture is the result of both molecular attraction (adhesion) of the material of the retainer **222** to the material of the suture **224** and due to a mechanical interconnection between the material of the retainer **222** and the material of the suture **224**. Thus, as the material of the retainer **222** cools, it mechanically grips the suture **224** so that the suture is held against movement relative to the retainer by interfacial forces between the material of the retainer and the material of the suture. Thus, there is a fusing of the material of the retainer **222** to the material of the suture **224** along the portions **238** and **240** of the suture.

[**0078**] The suture **224** is formed of a plastic material which may be a biopolymer. In one specific embodiment of the invention, the suture is formed of polyglycolide (P-G) ($C_4H_4O_4$) which is commercially available under the trademark Dexon. Polyglycolide is a crystalline material (40-55% crystallinity) that melts at about 225° Celsius. Although the suture **224** is a monofilament suture having a continuous cylindrical outer side surface **242**, it is contemplated that this suture could be formed in a different manner. For example, the suture could be a braided suture.

[**0079**] It is also contemplated that the suture **224** may be formed of a high glycolide-based copolymer, specifically a

10/90 P-LL/G (10% poly l-lactide and 90% glycolide) which is commercially available under the trademark "Vicryl". "Vicryl" is a crystalline material that melts at about 205° Celsius. "Vicryl" can be used for either a monofilament or braided suture.

[0080] The retainer 222 is also a plastic material which may be a biopolymer. In one specific embodiment of the invention, the retainer 222 is formed of poly dl lactide (P-DLL) ($C_6H_8O_4$) and is amorphous and has a processing temperature of approximately 120° Celsius. The transition temperature range of poly di lactide will vary depending upon the specific characteristics of the material. However, the retainer 222 of FIGS. 12-15 had a transition temperature range of from about 75° Celsius to about 120° Celsius.

[0081] In another specific embodiment of the invention, the retainer 222 is formed of poly dl lactide (P-DLL) ($C_6H_8O_4$) and poly l lactide (P-LL) ($C_6H_8O_4$) copolymer and is a material having a melt temperature of approximately 165° Celsius. The transition temperature range of the poly dl lactide and poly l lactide copolymer will vary depending upon the specific characteristics of the copolymer and is from about 75° Celsius to about 180° Celsius. In still another specific embodiment of the invention, the retainer 222 is formed of poly l lactide (P-LL) and has a melt temperature of approximately 145°-185° Celsius. A transition temperature range of poly l lactide is from about 70° Celsius to about 185° Celsius.

[0082] It is contemplated that the retainer 222 may be formed of many different types of plastic materials. However, it is believed that biopolymers may be preferred. It is contemplated that polymers of lactic acid, lactides l-lactides, and isomers of lactic acids and/or lactides may be preferred. Of course, the suture 224 can also be formed of many different types of plastic materials.

[0083] Although it is presently preferred to form the suture 224 and retainer 222 of different materials, the suture and retainer could be formed of the same material if desired. By forming the suture 224 of a material having a transition temperature range which is at least partially above the transition temperature range of the retainer 222, bonding of the retainer to the suture without significant deformation of the suture is facilitated.

[0084] In the embodiment of the retainer 222 illustrated in FIGS. 12 and 13, the plastic material of the retainer 222 is heated to a temperature in its transition temperature range by applying heat to a portion of the retainer disposed between the two passages 232 and 234. This results in a central portion of the plastic material forming the retainer 222 being heated into its transition temperature range while the outer circumference of the cylindrical retainer 222 is maintained at a temperature below the transition temperature range of the plastic material of the retainer.

[0085] In the specific embodiment of the retainer 222 illustrated in FIGS. 12 and 13, a generally conical recess 250 is formed in the central portion of the retainer 222. The recess 250 (FIG. 13) is spaced equal distances from the passages 232 and 234 and has a central axis which is parallel to the central axes of the passages 232 and 234. The central axis of the recess 250 is coincident with a central axis of the cylindrical retainer 222. In this specific embodiment of the invention, a heater element 254 having a conical end portion

256 is used to heat the retainer 222. Of course, other devices, such as a laser, could be used to heat the retainer 222.

[0086] After the portions 238 and 240 of the suture 224 have been inserted into the openings or passages 232 and 234 and the suture and retainer moved to the desired positions relative to the body tissue 226 and 228, the heater element 254 is inserted into the recess 250. Heat is conducted from the heater element 224 to the plastic material in the central portion of the retainer 222. The plastic material in the central portion of the retainer 222 is heated into its transition temperature range. As this occurs, the plastic material in the central portion of the retainer 222 changes from a solid condition in which it has a fixed form to a viscous condition. The plastic material adjacent to the cylindrical outer side surface of the retainer is not heated into the transition temperature range and maintains its original configuration.

[0087] When the plastic material in the central portion of the retainer 222 has been heated into the transition temperature range and has a viscous condition, the material readily flows and molds itself around the outer side surface 242 (FIG. 15) of the suture 224. As this occurs, the configuration of the suture 224 remains unaltered and there is no significant deformation of the suture 224. The heating element 254 is then removed from the recess 250 and the plastic material of the retainer 222 is cooled to a temperature below the transition temperature of the material. As the plastic material of the retainer 222 is cooled to a temperature below its transition temperature, the plastic material bonds to the suture 224 to provide a solid interconnection between the retainer and the suture.

[0088] In the embodiment of the invention illustrated in FIGS. 12-15, the suture 224 is a monofilament suture. In the embodiment of the invention illustrated in FIG. 16, the suture is a braided suture. Since the embodiment of the invention illustrated in FIG. 16 is generally similar to the embodiment of the invention illustrated in FIGS. 12-15, similar numerals will be utilized to designate similar components, the suffix letter (a) being associated with the embodiment of the invention illustrated in FIG. 16 to avoid confusion.

[0089] A retainer 222a formed of a plastic material is bonded to a suture 224a by heating the plastic material of the retainer 222a into its transition temperature range. After the plastic material of the retainer 222a has flowed around the suture 224a while the plastic material of the suture is at a temperature below the transition temperature range of the plastic material of the suture, the plastic material of the retainer is cooled to a temperature below the transition temperature range of the plastic material of the retainer. As the plastic material of the retainer 222a is cooled, a secure bond is obtained between the plastic material of the retainer 222a and the suture 224a. This secure bond is obtained without significant deformation of the suture 224a.

[0090] In accordance with a feature of the embodiment of the invention illustrated in FIG. 16, the suture 224a is a braided suture. Thus, the suture 224a is formed by plurality of monofilament strands which are intertwined to form the braided suture 224a. When the plastic material of the retainer 222a is heated to a temperature above its transition temperature, the plastic material of the retainer 222a flows between and around the strands of the braided suture 224a.

Upon cooling of the plastic material of the retainer **222a** to a temperature below its transition temperature, a secure bond is obtained between the material of the retainer **222a** and the strands of the braided suture **224a**.

[0091] In the embodiment of the invention illustrated in FIG. 17, the polymer chains of the plastic material forming the retainer are oriented relative to the suture. The orientation of the polymer chains of the retainer are such that the bonding which is obtained between the suture and the retainer includes a mechanical interconnection due to contracting of the polymer chains as the plastic material of the retainer is heated. Since the embodiment of the invention illustrated in FIG. 17 is generally similar to the embodiment of the invention illustrated in FIGS. 12-15, similar numerals will be utilized to designate similar components, the suffix letter "b" being associated with the numerals of FIG. 17 in order to avoid confusion.

[0092] The retainer **222b** has a generally cylindrical configuration. The suture **224b** has portions which extend through the retainer **222b**. Portions of the suture **224b** are disposed in passages (not shown) corresponding to the passages **232** and **234** of FIG. 12. The retainer **222b** and suture **224b** are formed of the same plastic materials as the retainer **222** and suture **224** of FIGS. 12-15.

[0093] In accordance with a feature of the embodiment of the invention illustrated in FIG. 17, the retainer **222b** has polymer chains, illustrated schematically by lines **262**, which are disposed in a predetermined orientation relative to the retainer **222b**. In the illustrated embodiment of the invention, the polymer chains **262** are orientated with their longitudinal axes extending parallel to the central axis of the cylindrical retainer **222b** and parallel to the longitudinal axes of the portions of the suture **224b** disposed within passages in the retainer.

[0094] Upon heating of the central portion of the retainer **222b**, the polymer chains **262** of the plastic material in the central portion of the retainer **222b** contract in an axial direction. Thus, the distance between circular end surfaces **264** and **266** of the retainer **222b** decreases to a greater extent and the outside diameter of the retainer **222b**. This results in a mechanical gripping of the portions of the suture **224b** disposed within the retainer **222b** by the plastic material of the retainer.

[0095] In the embodiments of the invention illustrated in FIGS. 12-17, portions of the suture are disposed in cylindrical passages which extend through the retainer and have central axes which are parallel to a central axis of the retainer. In the embodiment of the invention illustrated in FIG. 18, portions of the suture extend through retainer passages which are skewed relative to the central axis of the retainer. Since the embodiment of the invention illustrated in FIG. 18 is generally similar to the embodiments of the invention illustrated in FIGS. 12-17, similar numerals will be utilized to designate similar components, the suffix letter "c" being associated with the numerals of FIG. 18 to avoid confusion.

[0096] In the embodiment of the invention illustrated in FIG. 18, a cylindrical retainer **222c** is formed of a plastic material. A pair of passages **232c** and **234c** are formed in the retainer **222c**. A suture **224c**, formed of a plastic material, has portions **238c** and **240c** which are received in the

passages or openings **232c** and **234c**. A central recess **250c** is formed in the retainer **222c** to receive a heater element **254c** when the plastic material of the retainer **222c** is to be heated. The retainer **222c** and suture **224c** are formed of the same plastic materials as the retainer **222** and suture **224** of FIGS. 12-15.

[0097] In accordance with a feature of the embodiment of the invention illustrated in FIG. 18, the passages **232c** and **234c** have central axes which are skewed in an acute angle to the central axis of the retainer **222c**. Thus, the suture **224c** is inserted into the passage **232c** through a circular opening **272** in a circular end surface **266c** of the retainer **222c**. The passage **232c** has axially tapering side surface which forms a portion of a cone. The axially tapering configuration of the side surface of the passage **232c** enables the side surface of the passage to securely grip the suture **224c** at a location where an oval opening **274** is formed in the cylindrical outer side surface of the retainer **222c**. The longitudinal central axis of the passage **232c** is skewed at an acute angle relative to the central axis of the cylindrical retainer **222c**.

[0098] The portion **240c** of the suture **224c** is inserted into the passage **234c**. The passage **234c** has the same tapered configuration as the passage **232c**. The longitudinal central axis of the passage **234c** is skewed at an acute angle to the central axis of the cylindrical retainer **222c**. The longitudinal central axis of the passage **234c** is also skewed at an acute angle to the central axis of the passage **232c**.

[0099] During use of the apparatus illustrated in FIG. 18, the suture **224c** is placed in a desired position relative to body tissue **226c** and **228c**. The portions **238c** and **240c** are then inserted through the passages **232c** and **234c** in the retainer **222c**. The suture **224c** is then tightened to position the retainer **222c** relative to the body tissue **226c** and **228c**.

[0100] Once this has been done, the material of the retainer **222c** is heated by inserting a heater element **254c** into the recess **250c** in the central portion of the retainer **222c**. In this specific embodiment of the retainer **222c** illustrated in FIG. 18, the polymer chains of the plastic material forming the retainer **222c** are oriented with their longitudinal axes extending parallel to the longitudinal central axis of the retainer **222c**, in the same manner as illustrated schematically by the lines **262** for the retainer **222b** in FIG. 17. Therefore, upon heating of the retainer **222c**, the polymer chains contract to grip the portions **232c** and **234c** under the influence of forces extending transversely to the longitudinal central axes of the portion **238c** and **240c** of the suture **224c**.

[0101] As the material in the central portion of the retainer **222c** is heated into its transition temperature range, the material of the retainer flows around the portions **238c** and **240c** of the suture **224c** disposed in the passages **232c** and **234c**. The temperature of the material forming the retainer **222c** is maintained at a temperature which is below the transition temperature for the plastic material of the suture **224c**. Therefore, the plastic material of the retainer **222c** flows around the plastic material of the suture **224c** without significant deformation of the suture.

[0102] A secure bonding of the plastic material of the retainer **222c** to the plastic material of the suture **224c** is obtained by cooling the material of the retainer to a temperature below its transition temperature. This secure bond-

ing is obtained without significant deformation of the suture 224c so that the suture maintains its strength and is capable of holding the body tissue 226c and 228e in a desired manner.

[0103] From the foregoing, it is apparent that the apparatus and methods of the embodiments of the invention illustrated in FIGS. 12-18 may be used in suturing body tissue. A portion 238 of a suture 224 is inserted into an opening in a retainer 222 formed of a plastic material. At least a portion of the retainer 222 is heated to a temperature in a transition temperature range of the plastic material forming the retainer. The suture 224 is maintained at a temperature below the transition temperature range of a plastic material forming the suture while the retainer 222 is heated. The plastic material of the retainer 222 flows around the plastic material of the suture 224. A bonding of the plastic material of the retainer 222 to the plastic material of the suture 224 is effected by cooling the plastic material of the retainer to a temperature below its transition temperature range. The foregoing steps are performed without significant deformation of the plastic material of the suture 224. It should be understood that the plastic materials of the sutures and retainers of the embodiments of the invention illustrated in FIGS. 16-18 are interconnected in the same manner as the embodiment of FIGS. 12-15.

[0104] From the above description of the invention, those skilled in the art will perceive improvements, changes and modifications. Such improvements, changes and modifications within the skill of the art are intended to be covered by the appended claims.

What is claimed is:

1. A method of implanting a suture anchor in tissue comprising:

- positioning the suture anchor in tissue, a distal portion of the suture anchor having a mandrel connected thereto;
- moving the mandrel relative to a proximal portion of the suture anchor to increase the diameter of at least a portion of the suture anchor thereby locking the suture anchor to the tissue; and

removing at least a portion of the mandrel from the suture anchor.

2. The method of claim 1 further including the step of holding the proximal portion of the suture anchor in place while moving the mandrel.

3. The method of claim 2 wherein the mandrel is moved proximally to increase the diameter of the at least a portion of the suture anchor.

4. The method of claim 1 further including the step of creating an opening in the tissue.

5. The method of claim 4 wherein the suture anchor is positioned in the opening while the suture anchor has an inactivated diameter.

6. The method of claim 5 wherein the mandrel is moved to give the at least a portion of the suture anchor an activated diameter thereby locking the suture anchor in the opening, the activated diameter being greater than the inactivated diameter.

7. The method of claim 1 wherein the tissue is bone.

8. The method of claim 7 further including the step of holding the proximal portion of the suture anchor in place while moving the mandrel.

9. The method of claim 8 wherein the mandrel is moved proximally to increase the diameter of the at least a portion of the suture anchor.

10. The method of claim 7 further including the step of creating an opening in the bone tissue.

11. The method of claim 10 wherein the suture anchor is positioned in the opening while the suture anchor has an inactivated diameter.

12. The method of claim 11 wherein the mandrel is moved to give the at least a portion of the suture anchor an activated diameter thereby locking the suture anchor in the opening, the activated diameter being greater than the inactivated diameter.

* * * * *