

April 30, 1935.

R. LEDERFEIND

1,999,242

POWDER BOX

Filed Oct. 27, 1934

Fig. 1.

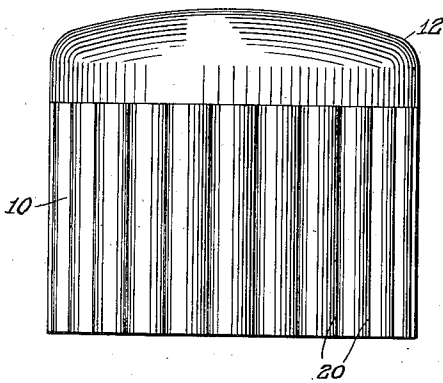

Fig. 2.

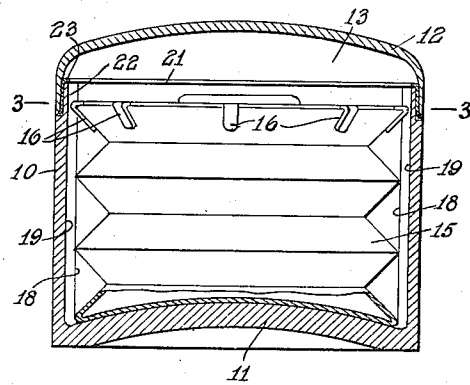
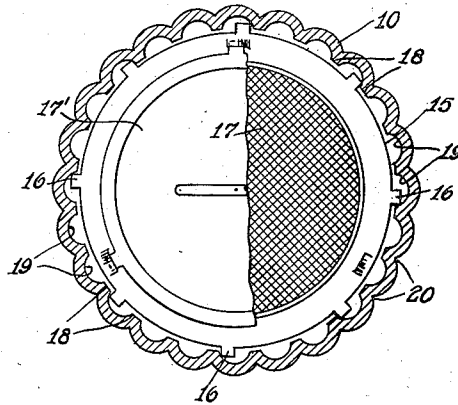

Fig. 3.



INVENTOR  
ROBERT LEDERFEIND  
BY *Paul Schmitt*  
ATTORNEY

# UNITED STATES PATENT OFFICE

1,999,242

## POWDER BOX

Robert Lederfeind, Long Beach, N. Y.

Application October 27, 1934, Serial No. 750,248

5 Claims. (Cl. 132-82)

The invention relates to powder cases or boxes especially adapted for enclosing a loader or filler element, containing powder or similar material in loose form, together with a puff or similar element designed to apply the powder material.

In a copending application for Letters Patent of the United States, Serial No. 700,950, filed Dec. 5, 1933, as well as in a further copending application Serial No. 738,267, filed Aug. 3, 1934, both assigned to applicant, there is disclosed a loader element comprising a seamless, one-piece, elastic rubber receptacle having at its outer end closure means for the receptacle outlet, the closure means in the latter application embodying tabs which clamp the elastic container material between superposed rings adapted to affording closing means for the receptacle outlet.

The present invention has for an object the provision of a box or case of thin, though substantial, material to enclose a loader element of the aforesaid nature and, particularly, to secure such element against rotational movement within its box, more especially when manipulating an associated cover element by partial rotation thereof, to allow of withdrawing powder from the loader element, as well as to reseal the loader.

A further object of the invention resides in the provision of a box or case which may be inexpensively finished to provide a pleasing appearance, for example by constructing the same of plastics or molded material such as a phenolic condensation product.

A still further object of the invention resides in the provision of a box in which a loader element of the nature of that set forth in the aforesaid application Serial #738,267 may be conveniently housed and accommodated, and the frictional resistance to collapse materially reduced through minimizing of actual lateral contact with the adjacent inner surface of the case.

Still another object of the invention resides in a construction of the box which will admit of convenient sealing of its contents against tampering.

In carrying out the invention, a box is provided of a more or less flexible material such as to allow of slight deformation to thereby securely hold to the top of the box a suitable lid or cover member. Around its inner wall, moreover, the box is provided with vertically disposed ribs or projections, spaced more or less to conform to the positions of the aforesaid tabs clamping the closure means at the outlet of the loader element which the box is designed to receive. These ribs thus provide channels into which the tabs aforesaid fit themselves to secure the loader element against rota-

tional movement relative to its surrounding case or box, said tabs being held against the sides of the ribs. These latter, in addition to anchoring the loader against undue movement during use, serve to stiffen the box of which they are an integral part, so that the same may be made relatively thin; and, if desired for appearance sake and greater degree of flexibility, the box may be fluted or indented longitudinally over its exterior wall opposite the said ribs.

The nature of the invention, however, will best be understood when described in connection with the accompanying drawing, in which:

Fig. 1 is a front elevation of the novel box.

Fig. 2 is a vertical section therethrough with loader element in position; and with the material constituting the box shown on an exaggerated scale.

Fig. 3 is a horizontal section, taken on the line 3-3, Fig. 2, but with the box cover and temporary seal removed.

Referring to the drawing, 10 designates an outer casing or box which may be variously shaped, for example, of cylindrical conformation and provided with the convex bottom 11 to assist in directing powder toward a sieve over the top of a loader element resting thereon and hereinafter more fully described. The said box is preferably composed of molded material, as a plastic such as a phenolic condensation product; and its walls are made relatively thin to be more or less flexible. A lid or cover 12 of the same material is arranged to fit over the outer end of the box and may be concaved interiorly to provide a space 13 above the box to receive a puff or like element (not shown) and manipulated in well-known manner for withdrawing powder from the interior of said box.

Furthermore, the box is designed more especially to receive a loader element for the powder rather than to receive the powder directly. Thus, a loader element 15 of the nature of that disclosed in the aforesaid applications and of a diameter somewhat less than that of the box 10, particularly one provided with a plurality of top-securing tabs 16 at its outer end, is to be mounted within said box to rest upon the bottom 11 thereof. As shown, a sieve member 17 closes the top of the loader element, being held thereto by the tabs as is more fully set forth in the aforesaid application Serial #738,267; and a cover element 17' is arranged to be removably associated therewith in any suitable manner to close the loader element when not in use.

Heretofore, it has been found that such loader

element would have a tendency to be displaced angularly or have a rotational movement within the box, particularly when removing the said cover element or replacing the same. With the loader element provided with the tabs 16, these tabs may be caused to act as restraining means in conjunction with vertically disposed ribs 18 which project inwardly from the inner wall of the box to provide a series of longitudinal channels 19 into which the respective tabs are located when inserting a loader into its box. The said ribs, furthermore, serve as bearing surfaces for the outer surface of the loader element, displacing it somewhat from the inner wall of the box and thus minimizing contact resistance to collapse of the said loader element when exerting pressure thereon, for example, by a powder puff when it is desired to withdraw some of the powder contents.

The said ribs, for example, may conveniently be provided in the molding of the box and simultaneously, if desired, with the provision of vertical indentations or flutings 20 in the outer wall of the box and located opposite the said ribs. This will provide for a more or less flexible wall, sufficiently stiffened by the said ribs, to satisfactorily retain the cover 12 to the box, and particularly to accommodate a clamping ring for a temporary seal.

Thus, in shipping or in storing the box with loader element mounted therein, it is desirable to provide a temporary seal over the sieve 17 with cover 17' and top of said box. This may be accomplished conveniently by means of a thin sheet of rupturable material, such as transparent cellulose material, and formed into a cap 21 which is then fitted over the shouldered rim 22 of said box, and is permanently held thereat as by a rigid metal clamping ring 23 forced over its flange.

To obtain access to the loader element, it will then be necessary, of course, first to break the aforementioned seal, which seal not only protects the contents against atmospheric conditions until they are ready for use, but insures against tampering therewith. Cover 12 then fits over the clamping ring 23 shouldering on said rim, and as both the cap and the box are of more or less flexible material, a satisfactory fit is secured therebetween.

I claim:

1. A box for receiving a loader element comprising a one-piece, elastic rubber receptacle and containing powder to be dispensed from said box,

the top of the receptacle being provided with closure means having outwardly and downwardly extending tabs, and the said box being channelled longitudinally over its inner face to receive the said tabs and anchor the loader element against rotational movement.

2. A box for receiving a loader element comprising a one-piece, elastic rubber receptacle and containing powder to be dispensed from said box, the top of the receptacle being provided with closure means having outwardly and downwardly extending tabs, and the said box being indented inwardly and longitudinally to provide inwardly projecting longitudinal ribs affording channels to receive the said tabs and anchor the loader element against rotational movement.

3. A box of flexible material for receiving a loader element comprising a one-piece, elastic rubber receptacle and containing powder to be dispensed from said box, the top of the receptacle being provided with closure means having outwardly and downwardly extending tabs, and the said box being channelled longitudinally over its inner face to receive the said tabs and anchor the loader element against rotational movement.

4. A box for receiving a loader element comprising a one-piece, elastic rubber receptacle and containing powder to be dispensed from said box, the top of the receptacle being provided with closure means having outwardly and downwardly extending tabs, the said box being channelled longitudinally over its inner face to receive the said tabs and anchor the loader element against rotational movement, a rupturable sealing element fitted over the rim of the box, and a clamping member mounted thereover to permanently secure the sealing element to the top of the box.

5. A box for receiving a loader element comprising a one-piece, elastic rubber receptacle and containing powder to be dispensed from said box, the top of the receptacle being provided with closure means having outwardly and downwardly extending tabs, the said box being channelled longitudinally over its inner face to receive the said tabs and anchor the loader element against rotational movement, a rupturable sealing element fitted over the shouldered rim of the box, and a clamping ring surrounding a flanged portion of said sealing element to permanently secure the same to the rim.

ROBERT LEDERFEIND.