

(19) World Intellectual Property
Organization
International Bureau



(43) International Publication Date
8 July 2004 (08.07.2004)

PCT

(10) International Publication Number
WO 2004/057196 A1

- (51) International Patent Classification⁷: **F04F 5/54**, Alexander, Guy [GB/GB]; 11 Elm Tree Cottages, Water End Road, Potten End, Berkhamstead HP4 2SH (GB).
5/24, 5/48
- (21) International Application Number: PCT/GB2003/005552
- (22) International Filing Date: 18 December 2003 (18.12.2003)
- (25) Filing Language: English
- (26) Publication Language: English
- (30) Priority Data: 0229604.4 19 December 2002 (19.12.2002) GB
- (71) Applicant (for all designated States except US): **PUR-SUIT DYNAMICS PLC** [GB/GB]; Unit 1, Anglian Business Park, Orchard Road, Royston, Hertfordshire SG8 5TW (GB).
- (72) Inventors; and
- (75) Inventors/Applicants (for US only): **FENTON, Marcus, Brian, Mayhall** [GB/GB]; 2 Bushmead Road, Eaton Socon, St Neots, Cambridgeshire PE19 8BP (GB). **WALLIS**,
- (74) Agent: **BUTLER, Lance**; Barker Brettell, 10-12 Priests Bridge, London SW15 5JE (GB).
- (81) Designated States (national): AE, AG, AL, AM, AT, AU, AZ, BA, BB, BG, BR, BW, BY, BZ, CA, CH, CN, CO, CR, CU, CZ, DE, DK, DM, DZ, EC, EE, EG, ES, FI, GB, GD, GE, GH, GM, HR, HU, ID, IL, IN, IS, JP, KE, KG, KP, KR, KZ, LC, LK, LR, LS, LT, LU, LV, MA, MD, MG, MK, MN, MW, MX, MZ, NI, NO, NZ, OM, PG, PH, PL, PT, RO, RU, SC, SD, SE, SG, SK, SL, SY, TJ, TM, TN, TR, TT, TZ, UA, UG, US, UZ, VC, VN, YU, ZA, ZM, ZW.
- (84) Designated States (regional): ARIPO patent (BW, GH, GM, KE, LS, MW, MZ, SD, SL, SZ, TZ, UG, ZM, ZW), Eurasian patent (AM, AZ, BY, KG, KZ, MD, RU, TJ, TM), European patent (AT, BE, BG, CH, CY, CZ, DE, DK, EE, ES, FI, FR, GB, GR, HU, IE, IT, LU, MC, NL, PT, RO, SE, SI, SK, TR), OAPI patent (BF, BJ, CF, CG, CI, CM, GA, GN, GQ, GW, ML, MR, NE, SN, TD, TG).
- Published: — with international search report

[Continued on next page]

(54) Title: A PUMPING SYSTEM

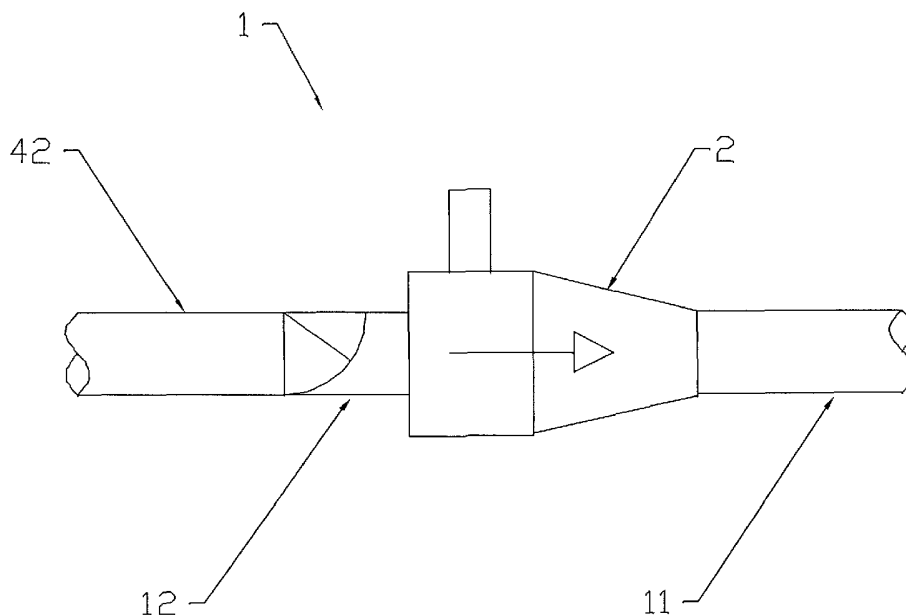

(57) Abstract: In a pumping system incorporating a fluid mover provided with a through passage (6) for a working fluid having an inlet (8) and an outlet (10) with an annular nozzle (4) let into the passage for the introduction of a transport fluid there is provided a pressure relief means (12) operable during start-up to facilitate the attainment of the desired pressure gradient across the pump.

WO 2004/057196 A1



For two-letter codes and other abbreviations, refer to the "Guidance Notes on Codes and Abbreviations" appearing at the beginning of each regular issue of the PCT Gazette.

A PUMPING SYSTEM

5 [0001] This invention concerns improvements in or relating to
pumping systems and in particular has reference to pumping
systems having essentially no moving parts.

10 [0002] In our co-pending UK International Patent Application No
PCT/GB2003/004400 wherein there is described a pump in which
the motive force is provided by the use of a condensable fluid,
e.g. steam, introduced into a through-housing open at each end,
the fluid to be pumped being induced through the housing by the
condensable fluid which possesses such properties that a
supersonic shock wave is created and upon condensation of the
15 steam an implosive force is generated giving rise to momentum
transfer and therefore impulsive thrust to the working fluid to be
pumped. Since no moving parts are involved in the pump *per*
se its operation is not adversely affected by extraneous influences
or contaminatory material which would cause damage in
20 conventional pumping mechanisms. However, since there are
no moving parts it is necessary to provide an easy way of
initiating operation of the pump.

25 [0003] An object of the present invention is to provide an improved
pumping system whereby the start-up of the system is facilitated.

30 [0004] According to a first aspect of the invention, there is provided
a pumping system comprising a fluid flow line including a pump
having a hollow body provided with a straight-through passage of
substantially constant cross section, an inlet at one end of the
passage and an outlet at the other end of the passage for the entry

and discharge respectively of a working fluid, a nozzle substantially circumscribing and opening into said passage intermediate the inlet and outlet ends thereof, an inlet communicating with the nozzle for the introduction of a condensable transport fluid, a mixing chamber being formed within the passage downstream of the nozzle, the nozzle being so disposed and configured that in use a supersonic shock wave is created within the mixing chamber by the introduction of the transport fluid, and pressure relief means associated with the fluid flow line actuatable for the purpose of system start-up whereby pressure is modulated so as to provide a desired pressure gradient across the pump.

[0005] According to a second aspect of the present invention a method of start-up for a pumping system according to the first aspect includes the steps of introducing the transport fluid to the nozzle to effect energy transfer to the working fluid, actuating pressure relief means to reduce pressure across the pump thereby to facilitate start-up by modulating the pressure prevailing within the fluid flow line whereby flow of the working fluid is induced through the passage, and deactivating the pressure relief means upon attainment of a desired pressure gradient across the pump.

[0006] The pressure relief means is conveniently provided to reduce the pressure head in the fluid flow line of the pumping system whether it operates on negative upstream pressure, positive downstream pressure or equalised pressure.

[0007] The pressure relief means may be in the form of a uni-directional valve disposed upstream of the inlet to the passage

which in practice by dint of its function enables the attainment of the desired pressure gradient across the pump.

5 [0008] Advantageously the transport fluid may be a condensable fluid such as steam which condenses during contact with the working fluid being pumped through the system and implodes causing low pressure conditions which enhance the suction effect and thus thrust of working fluid through and from the pump. In this connection the contents of our co-pending PCT Application
10 hereinbefore mentioned are imported into this specification as appropriate whereby the explanation of the pump configuration and its mode of operation is set out in detail.

15 [0009] The provision of the uni-directional or one-way valve upstream as defined lies in its function during start-up in that the initial introduction of the transport fluid can give rise to a back-flow thereof towards the inlet of the pump. The action of the uni-directional valve is to prevent such back-flow and to allow the build up of the pressure flow of the transport fluid in the
20 pumping direction. Once the parametric conditions have reached an appropriate level the uni-directional valve automatically opens and the working fluid is drawn therethrough.

25 [0010] In a modification of the invention there is provided a further pressure relief means, e.g. in the form of a second uni-directional valve, located downstream of the nozzle adapted to allow flow in the downstream direction only. In the case where the transport fluid is a condensable fluid this second valve performs a dual function in that during start-up it permits
30 condensation of the condensable fluid thereby generating a vacuum condition causing the upstream uni-directional valve to

open thus initiating flow through the pump and also prevents any flow back of fluid extraneous to the pump.

5 [0011] In a further modification of the pumping system of the present invention the pressure relief means is provided in the form of a by-pass for the fluid flow line and arranged as between downstream and upstream sides of the pump in the circumstance of an expected large back-pressure on the pump or large inertial losses in the pressure head pipework to overcome, to enable the
10 initiation of flow through the pump during start-up. The by-pass may be constituted by suitable piping and provided with a valve for the control of flow therethrough. Any transport and working fluid mixture passing through the by-pass may be exhausted to atmosphere or fed to the upstream or suction side of
15 the pump.

[0012] In a still further embodiment pressure relief means in the form of a bleed or suction pipe is provided for a priming fluid to prime the pump on the suction side during start-up or indeed
20 continuously in the event that the working fluid burden on the pump is significant. For example the working fluid may be a fluid with high viscosity or it may be a mixture of gas, *e.g.* air, and a liquid and in these instances the provision of a priming fluid during start-up would prove advantageous in initiating flow
25 through the pump. A continual or continuous bleed of such priming fluid may also be contemplated in the event that maintenance of the pumping rate becomes difficult by virtue of the working fluid properties. The priming fluid may be of any suitable type and from a convenient source, preferably in liquid
30 form. The priming fluid may be water or any other liquid compatible with the pumping system of the invention and

environmental regulations. The priming fluid may be a treatment fluid, for example a dispersant or a diluent. The priming fluid may be the same type of fluid as the working fluid.

5 [0013] In another embodiment of the present invention the pressure relief means may be constituted by a header tank and priming fluid may be provided from the header tank which may be automatically controlled to provide priming fluid over a set time thereafter to be discontinued. In the alternative or in addition
10 another header tank may be provided with an outflow controllable at a rate determined by an operator or by prevailing conditions within the system.

[0014] By way of example only, a number of embodiments of a
15 pumping system according to the invention is described below with reference to the accompanying drawings in which:

[0015] Figure 1 is a diagram of a fluid mover in the form of a pump;

20 [0016] Figure 2 is a diagram of a first embodiment;

[0017] Figure 3 is a diagram of a second embodiment;

[0018] Figure 4 is a diagram of a third embodiment;

25

[0019] Figure 5 is a diagram of a fourth embodiment;

[0020] Figure 6 is a diagram of a fifth embodiment;

30 [0021] Figure 7 is a diagram of a sixth embodiment;

[0022] Figure 8 is a diagram of a seventh embodiment; and

[0023] Figure 9 is a diagram of an eighth embodiment.

5

[0024] In the drawing of Figure 1 there is shown a pump 2 of the kind described in our co-pending International Patent Application No PCT/GB2003/004400 in which a nozzle 4 is provided circumscribing and opening into a passage 6 having an upstream inlet 8 and a downstream outlet 10 leading to a discharge pipe 11, shown in Figure 2. In operation a working fluid is pumped through the pump 2 with a transport fluid, for example steam, being introduced through the nozzle 4 into the passage 6 to generate a shockwave. The steam condenses and implodes causing a region of low pressure that enhances flow and increases the thrust in the fluid.

10

15

[0025] Referring now to Figure 2 a first embodiment of the system of the present invention is illustrated and includes pressure relief means in the form of a one-way valve 12 in modular form upstream of the inlet 8 and in the fluid flow line of the pumping system 1. With this valve 12 included in the fluid flow line, part of which is shown at 42, during start-up of the system the valve is closed thereby preventing the back-flow of the transport fluid issuing from the nozzle 4 through the passage 6. Once the forward flow of transport fluid has been established, the suction would actuate the valve 12 and enable full fluid flow through pipe 42. Equally upon shut-down, the cessation of transport fluid flow would occasion a loss of suction and the valve would shut thus preventing any backflow along the passage 6 into pipe 42.

20

25

30

[0026] In Figure 3 a second one-way valve 14 in modular form is provided downstream of the pump 2 with a pipe section 15 connected to the outlet of the pump and as part of the fluid flow line, and may be operable in unison with the valve 12 during the start-up procedure of the system 1. In this instance backflow into the pump 2 is prevented prior to the establishment of proper flow conditions within the system. As the required pumping pressure is being attained the valve 14 gradually opens and is fully open upon establishment of the designed pressure. This valve, as with the valve 12, could be used to give a throttling effect and thus provides a further control in the flow through the system 1 in addition to that provided by the transport fluid issuing from the nozzle 4.

15

[0027] In one mode of operation of the start-up of the pumping system of the invention in which the two one-way valves are provided, the flow of transport fluid, in this example steam, is introduced to the nozzle 4 and its pressure would ensure the closure of the one-way valve 12 whilst the steam pressure opens the other one-way valve 14 to fill the intervening passage and pipework with steam. Upon rapidly stopping the steam supply flowing through the nozzle 4 the steam condenses within the pump 2 and the pipe 15 and in so doing causes a vacuum which effectively pulls the valve 12 open, thus initiating flow therethrough and into the pump. If then the steam supply is re-established at this stage the pump would then be primed with fluid having some velocity and operation of the pump 2 could then proceed in normal manner with the pull in one direction only from inlet to outlet.

20

25

30

[0028] A further possible inclusion in the fluid flow line of the pumping system 1 of the invention is a modular header tank 20 as shown in Figure 4 provided with a ball cock 22 for the supply thereto of a priming fluid. The tank 20 has an outlet controllable by a valve 24 leading to a Tee-piece 26 attachable to the inlet or suction side of the pump 2. The purpose of the header tank 20 would be to provide a renewable supply of a priming fluid during start-up principally or also during the operation of the system dependent upon requirements. The fluid would be induced through the pump and provide an initial priming thereof. Once proper flow of the working fluid had been established by virtue of the issuance of the transport fluid from the nozzle 4, the flow of priming fluid would be discontinued unless a bleed of priming fluid into the system proved to be beneficial. In this event, the valve 24 would be used to control the seeding of the working fluid.

[0029] An alternative form of modular header tank is shown at 30 in Figure 5 which in operation is charged with a predetermined volume of priming fluid and is provided with an automatic shut-off that may be in the form of a plug 32. Once the contents of the tank 30 have been discharged the plug 32 blocks the outlet 34 thereof. It is to be understood that any alternative control other than the plug may be deployed for this purpose.

[0030] A fifth embodiment of pumping system according to the invention is shown in Figure 6 in which a bleed pipe 40 is provided as an element in the pumping system 1 and may communicate with a suitable source of priming fluid diagrammatically shown at 44, the function being to provide priming fluid during start-up. The source of the priming fluid

may be a distinct reservoir provided for that purpose or may be the body of working fluid or may be a convenient local supply of fluid.

5 [0031] A suction pipe 42 is conveniently provided and is attachable to the pump 2 as an inlet conduit and as part of the fluid flow line. It may in certain applications constitute an inlet nozzle for engaging in the fluid material to be transported which may be lying on a surface, for example a solid or liquid surface, or
10 indeed below water level, e.g the sea bed. Essentially the pipe is a pick-up for the material to be transported wherever it may be lying.

[0032] A sixth embodiment of the present invention is shown in
15 Figure 7 and essentially comprises a combination of the second embodiment with the third, the fourth or the fifth embodiment such that in the event a priming fluid is employed, the one-way valve 12 is deployed upstream of the pump 2. The adoption of any one of the combinations indicated will be dictated by the
20 particular requirements of the pumping system and the fluids passing therethrough. For example in the event that a header tank or bleed pipe is included in the pumping system of the invention, it may be convenient to employ a one-way valve between the header tank and the pump. During the start-up mode the one-way
25 valve takes on a dual function in terms of stopping flowback of fluid upstream and also for the purpose described in relation to the first embodiment.

[0033] As shown in Figure 8 for start-up the system in a further
30 arrangement includes a by-pass 46 connected *via* a valve 48 and a Tee-piece 49 into the downstream side of the pump 2. The by-

pass 46 may be connected into the upstream side of the pump 2 via a conduit 45 or may discharge to atmosphere through a conduit 47 into a suitable reservoir. The use of this arrangement is intended when a large back-pressure or large inertial losses within the downstream or pressure head side of the pump are likely to be encountered, the by-pass providing a time delay to enable the pump to generate and establish sufficient pressure to overcome the back-pressure or the pressure head losses in the downstream pipework.

5

10

[0034] Referring now to Figure 9 there is illustrated a combination of the embodiments shown in Figures 4, 5, 6 and 7 to give comprehensive start-up capabilities dependent upon the specific requirements of the pumping system particularly with regard to expected parametric conditions and the characteristics of the fluid being pumped, be they liquids or liquids with solids. For example the valve 14 and the header or the bleed may be used in combination with the valve 48 whereby once flow is established through the pump 2, the valve 48 may be progressively closed. Such gradual closure may be controlled to coincide with the release of fluid from the header or the bleed, thereby ensuring even greater positive priming of the pump. A circuit of this character would be used for pumping particularly difficult fluids or fluids/solids mixtures or in a system in which high downstream pressure is likely to be encountered

15

20

25

[0035] All the features of the pumping system of the present invention are of modular form and may be included or withdrawn dependent upon the prevailing conditions with regard *inter alia* to the properties of the working fluid. Accordingly the system of the invention may include a combination of one or more of the

30

11

elements described together with the one-way valve 12 upstream of the pump 2 to facilitate start-up as shown in Figure 9. Different fluid circuits and modes of operation will be adopted to match requirements.

5

[0036] It will be understood that the priming fluid may be of any suitable type and may be the working fluid or a fluid drawn from an extraneous source.

10

CLAIMS

- 5 1. A pumping system comprising a fluid flow line **characterised**
by the inclusion of a pump having a hollow body provided with
a straight-through passage of substantially constant cross
section, an inlet at one end of the passage and an outlet at the
other end of the passage for the entry and discharge
10 respectively of a working fluid, a nozzle substantially
circumscribing and opening into said passage intermediate the
inlet and the outlet ends thereof, an inlet communicating with
the nozzle for the introduction of a condensable transport fluid,
a mixing chamber being formed within the passage downstream
15 of the nozzle, the nozzle being so disposed and configured that
in use a supersonic shock wave is created within the mixing
chamber by the introduction of the transport fluid, and pressure
relief means associated with the fluid flow line actuatable for the
purpose of system start-up whereby pressure is modulated to
20 provide the desired pressure gradient across the pump.
2. A pumping system according to Claim 1 **characterised in that**
the pressure relief means is provided to reduce the pressure
head in the fluid flow line when in use operating on negative
25 upstream pressure, positive downstream pressure or equalised
pressure.
3. A pumping system according to Claim 1 or 2 **characterised in**
that the pressure relief means is in the form of a uni-
directional valve disposed in the fluid flow line upstream of the
30 inlet to the passage of the pump.

4. A pumping system according to any one of the preceding claims **characterised in that** a further pressure relief means is located downstream of the nozzle.
- 5
5. A pumping system according to Claim 4 **characterised in that** the further pressure relief means is in the form of a unidirectional valve.
- 10
6. A pumping system according to Claim 1 **characterised in that** the pressure relief means is in the form of a controllable bypass for the fluid flow line arranged as between downstream and upstream sides of the pump.
- 15
7. A pumping system according to Claim 1 **characterised in that** the pressure relief means is in the form of a bleed provided for a priming fluid to prime the pump.
- 20
8. A pumping system according to Claim 1 **characterised in that** the pressure relief means is constituted by a header tank provided in association with the fluid flow line upstream of the pump for the provision of priming fluid to the pump.
- 25
9. A pumping system according to Claim 8 **characterised in that** the header tank is provided with a controllable discharge means.
- 30
10. A pumping system according to Claim 1 **characterised in that** the pressure relief means comprises a combination of a unidirectional valve disposed in the fluid flow line upstream of the inlet to the passage of the pump, a bleed provided for a

priming fluid to prime the pump or a header tank provided in association with the fluid flow line upstream of the pump for the provision of priming fluid to the pump.

- 5 11. A method of start-up for a pumping system as claimed in any one of the preceding claims **characterised** by the steps of introducing transport fluid to the nozzle to effect energy transfer to the working fluid, actuating the pressure relief means to reduce pressure across the pump thereby to facilitate start-up by modulating the pressure prevailing within the fluid flow line whereby flow of the working fluid is induced through the passage of the pump, and deactivating the pressure relief means upon attainment of a desired pressure gradient across the pump.
- 10
- 15 12. A method according to Claim 11 when dependent on Claim 2 or 3 **characterised in that** the pressure relief means is adapted to prevent back-flow within the fluid flow line during start-up.
- 20 13. A method according to Claim 11 when dependent upon Claim 4 **characterised in that** the supply of transport fluid is initiated and the further pressure relief means is adapted to open upon the initial injection of the transport fluid, the supply of transport fluid is stopped to promote condensation of the transport fluid during start-up thereby to generate a vacuum to induce fluid flow through the first mentioned pressure relief means.
- 25
- 30 14. A method according to Claim 11 when dependent upon Claim 6 **characterised in that** working fluid is by-passed to compensate for back-pressure or inertial losses.

- 5
15. A method according to Claim 11 when dependent on Claim 6 **characterised in that** working fluid and transport fluid are by-passed to compensate for back-pressure or inertial losses.
- 10
16. A method according to Claim 11 when dependent on Claim 10 **characterised in that** working fluid and/or transport fluid and/or priming fluid are by-passed to compensate for back-pressure or inertial losses.
- 15
17. A method according to Claim 14 **characterised in that** the by-passed fluid is exhausted to atmosphere or recirculated into the fluid flow line upstream of the pump.
- 20
18. A method according to Claim 11 when dependent on Claim 7 **characterised in that** a priming fluid is introduced through the bleed for priming the pump during start-up.
- 25
19. A method according to Claim 18 **characterised in that** the introduction of the priming fluid is continuous or intermittent.
- 30
20. A method according to Claim 18 or 19 **characterised in that** the priming fluid is a diluent.
21. A method according to Claim 18 or 19 **characterised in that** the priming fluid is a dispersant.
22. A method according to Claim 18 or 19 **characterised in that** the priming fluid is the same type of fluid as the working fluid.

23. A method according to Claim 22 **characterised in that** the priming fluid is water.
24. A method according to any one of Claims 11 to 23
5 **characterised in that** the transport fluid is a condensable fluid.
25. A method according to Claim 24 **characterised in that** the condensable fluid is steam.
- 10 26. A method according to any one of the preceding Claims 11 to 25 **characterised in that** the working fluid is a liquid or a mixture or liquids and solids.

1/9

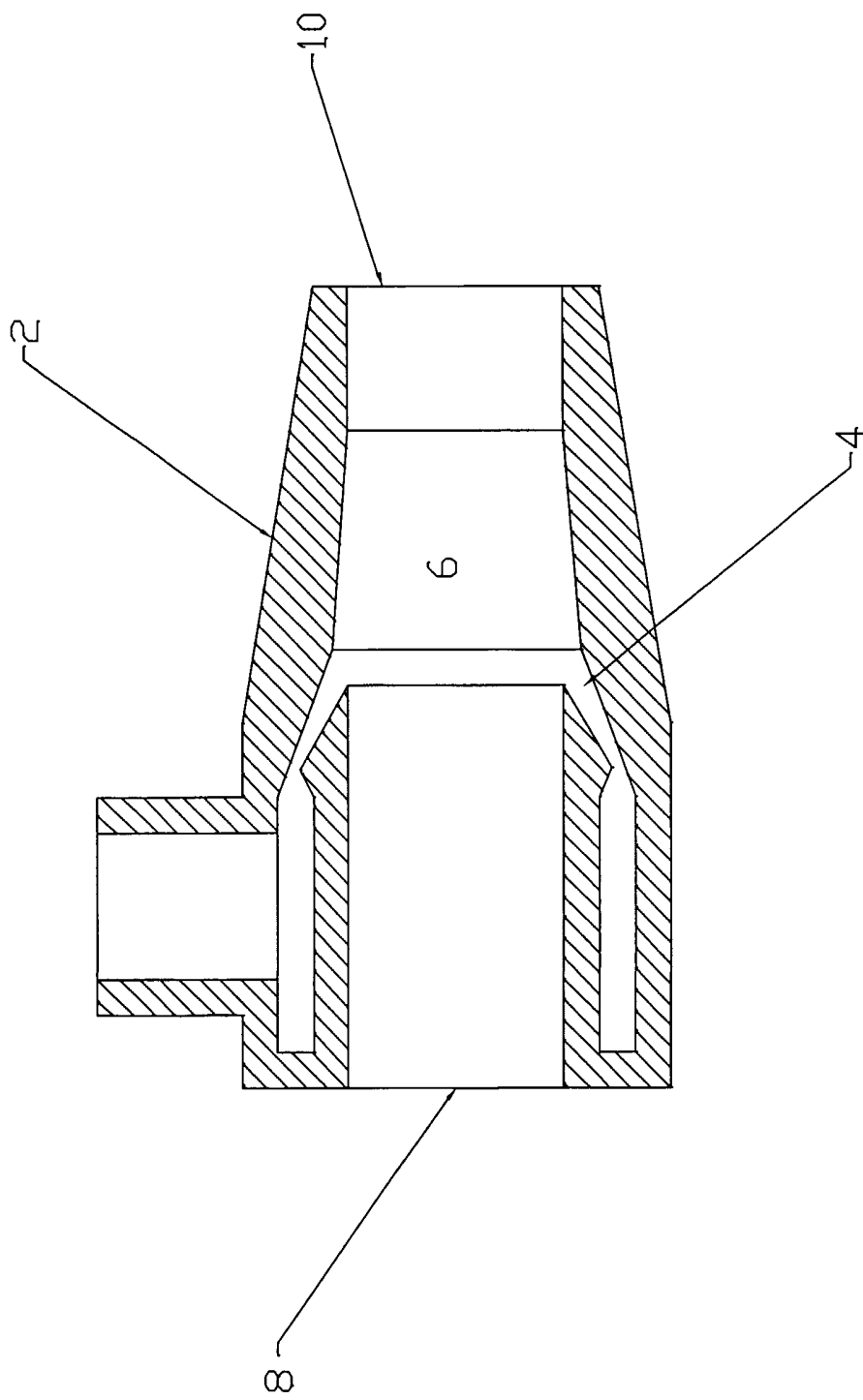

Figure 1

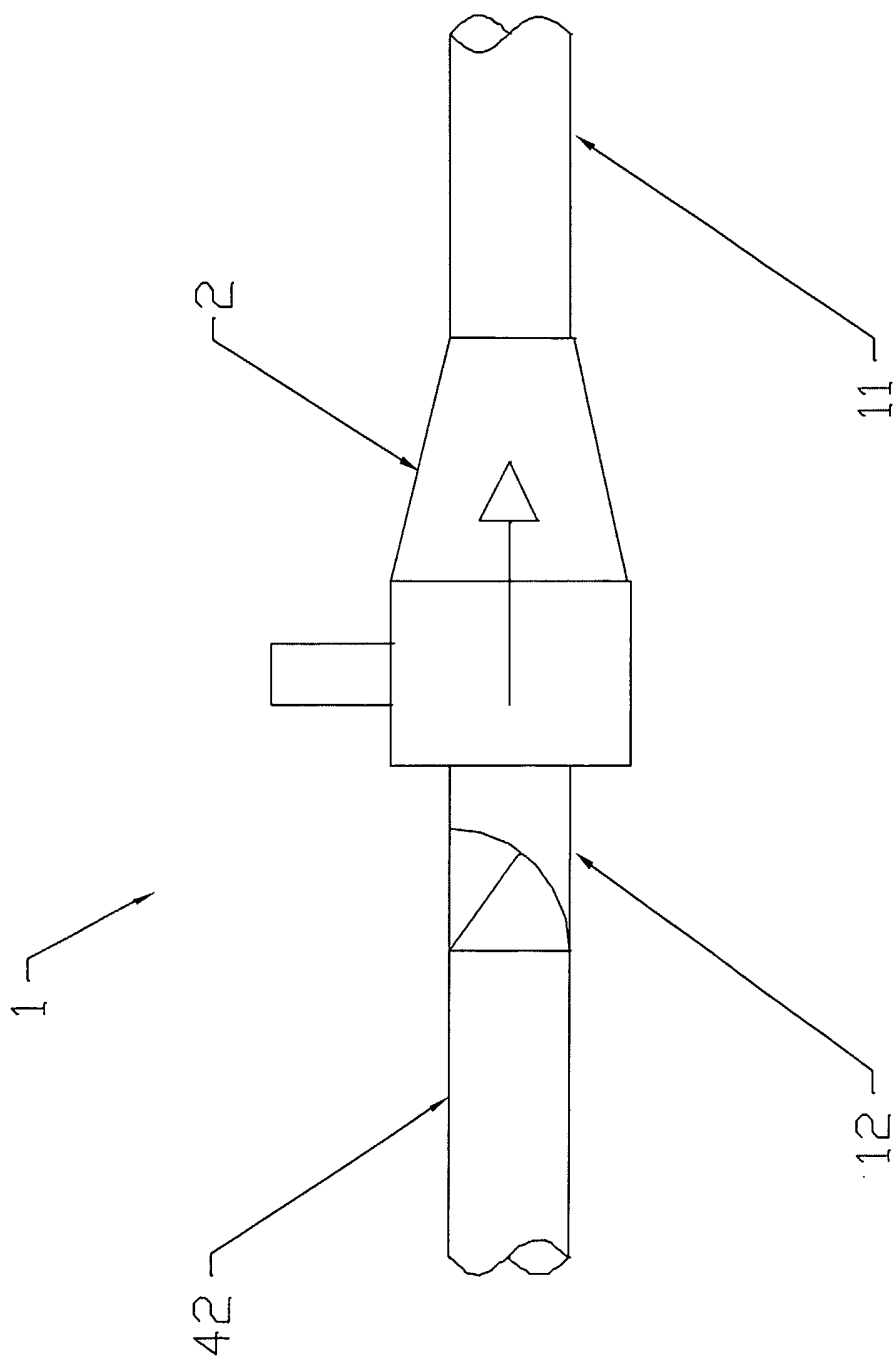

Figure 2

3/9

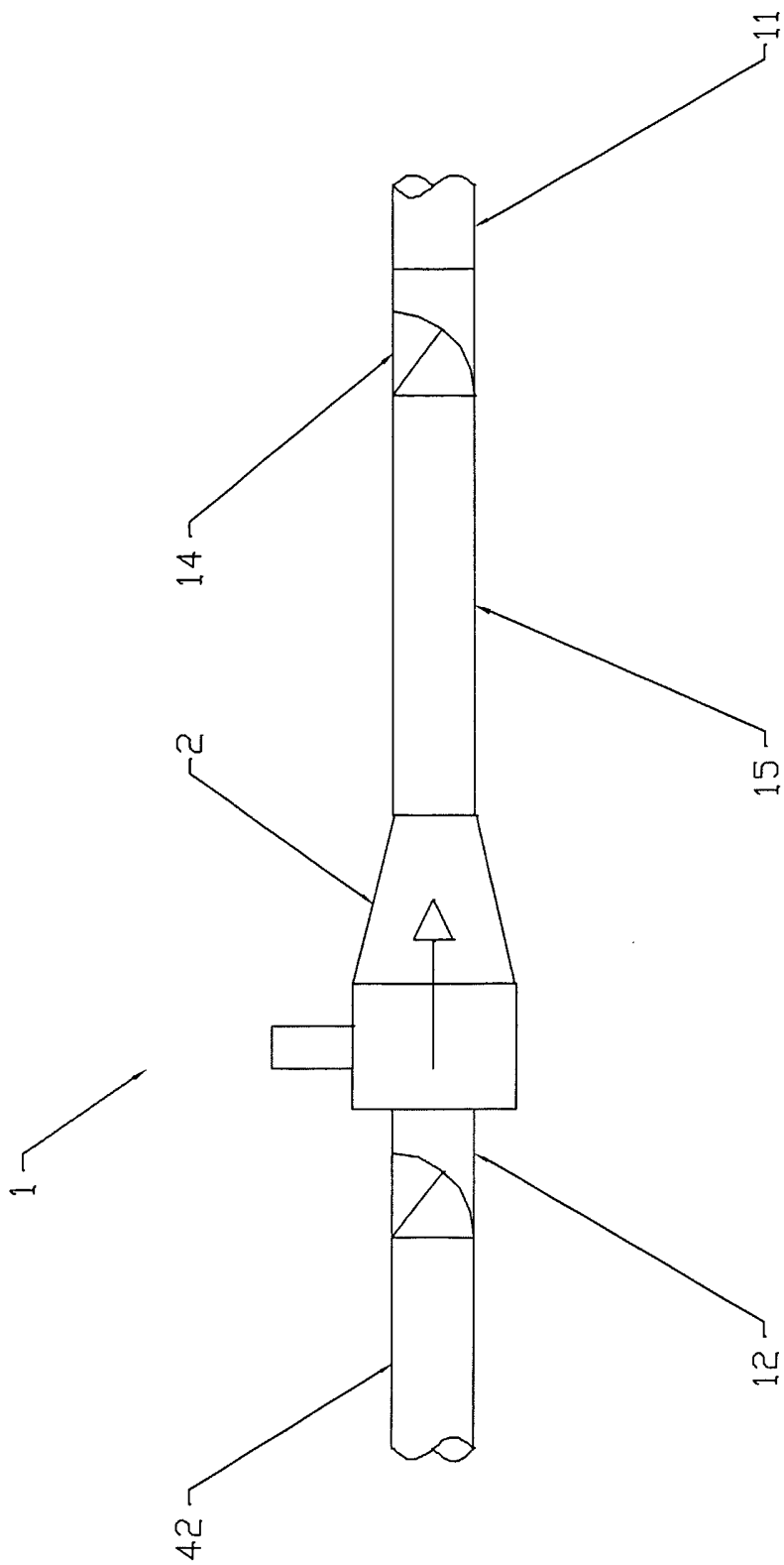

Figure 3

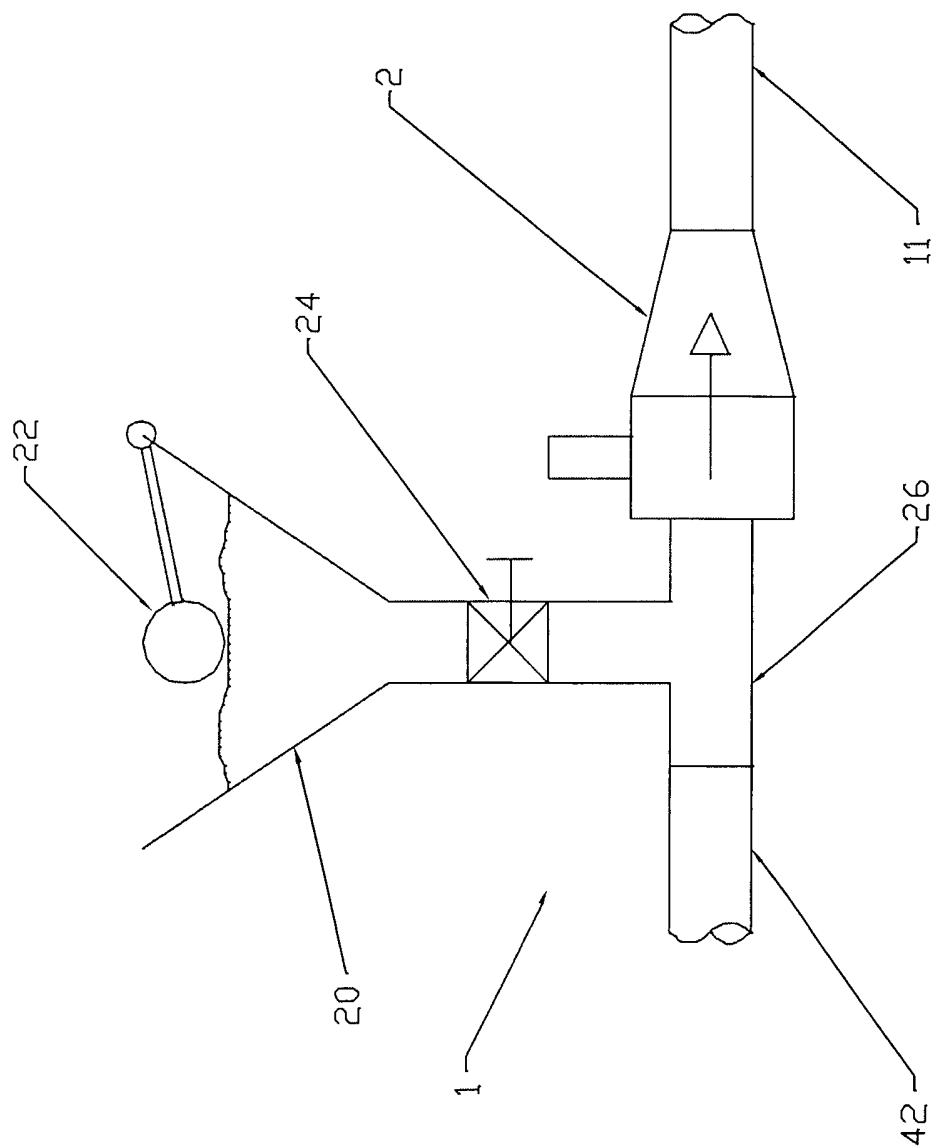

Figure 4

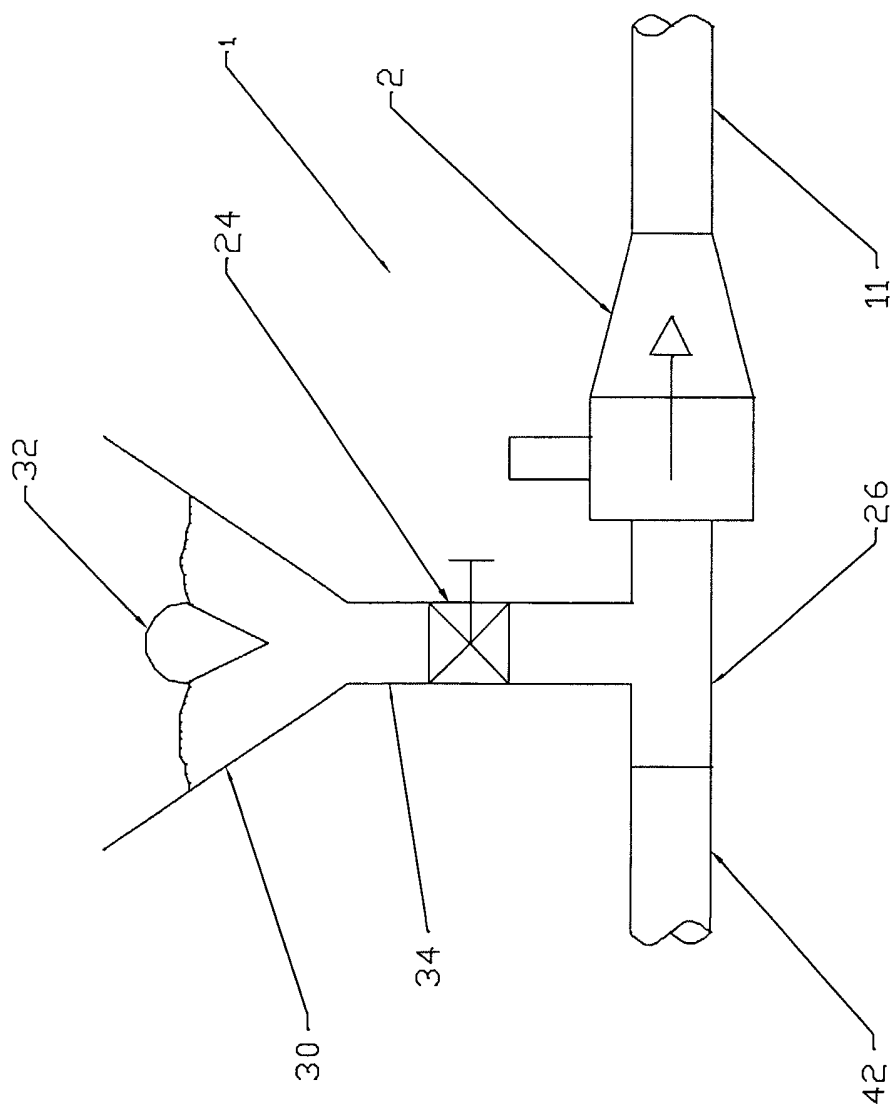

Figure 5

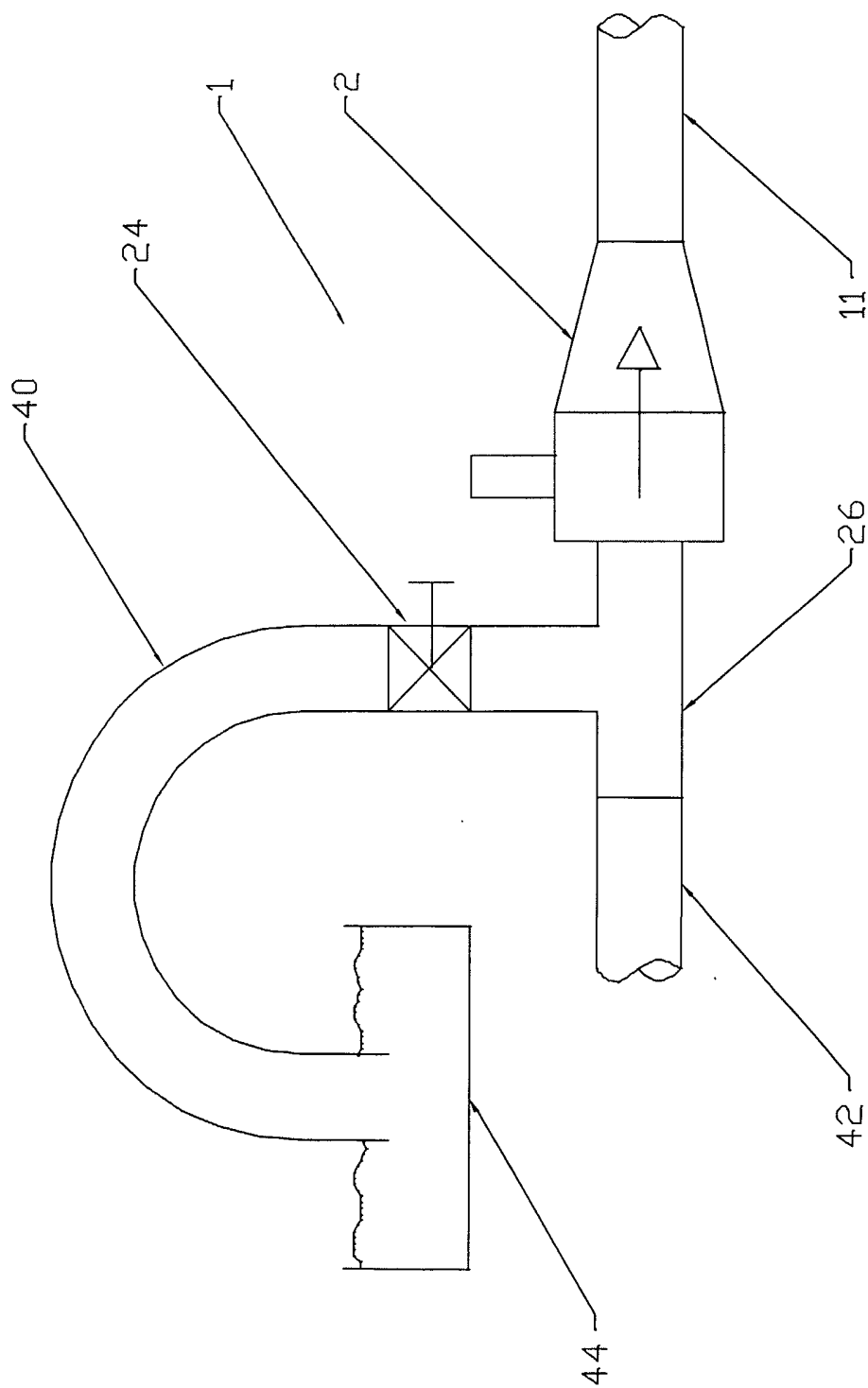

Figure 6

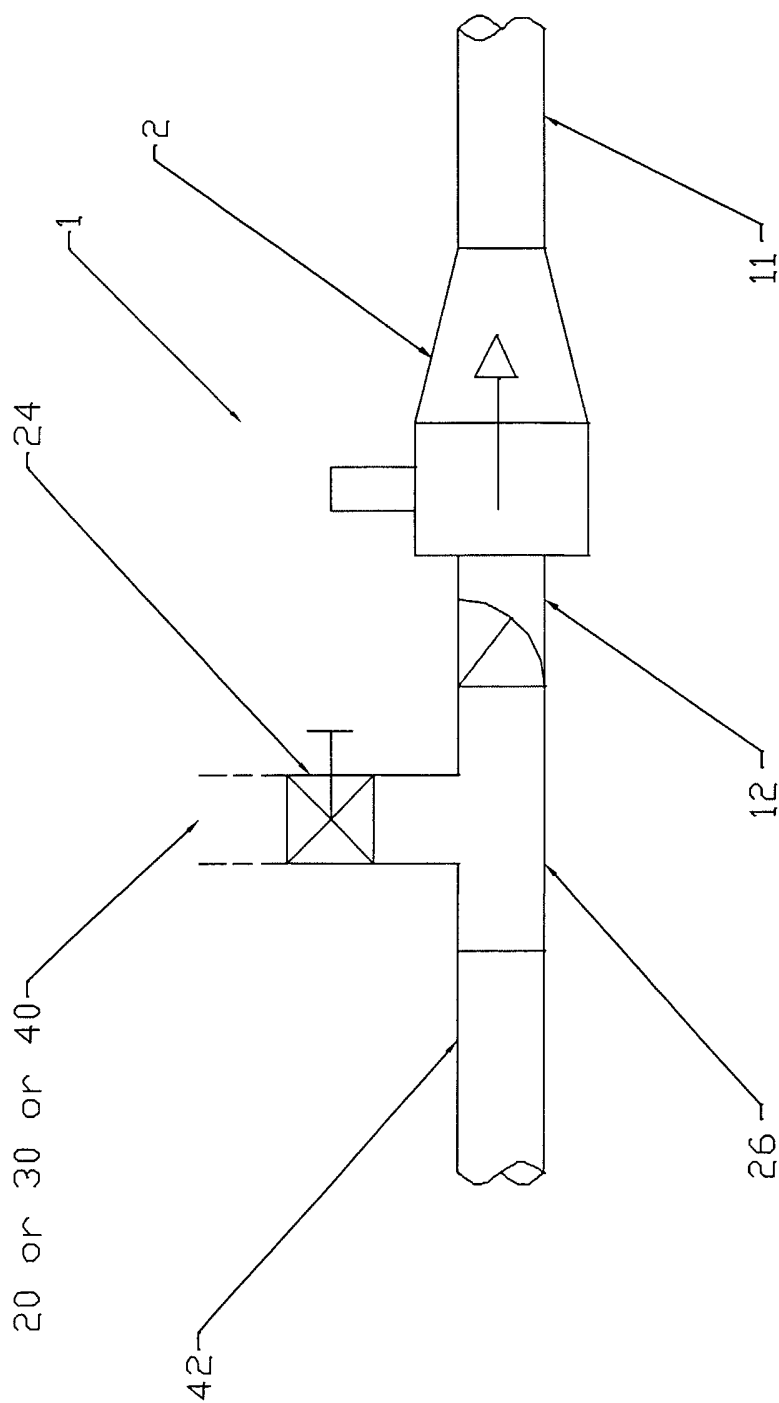

Figure 7

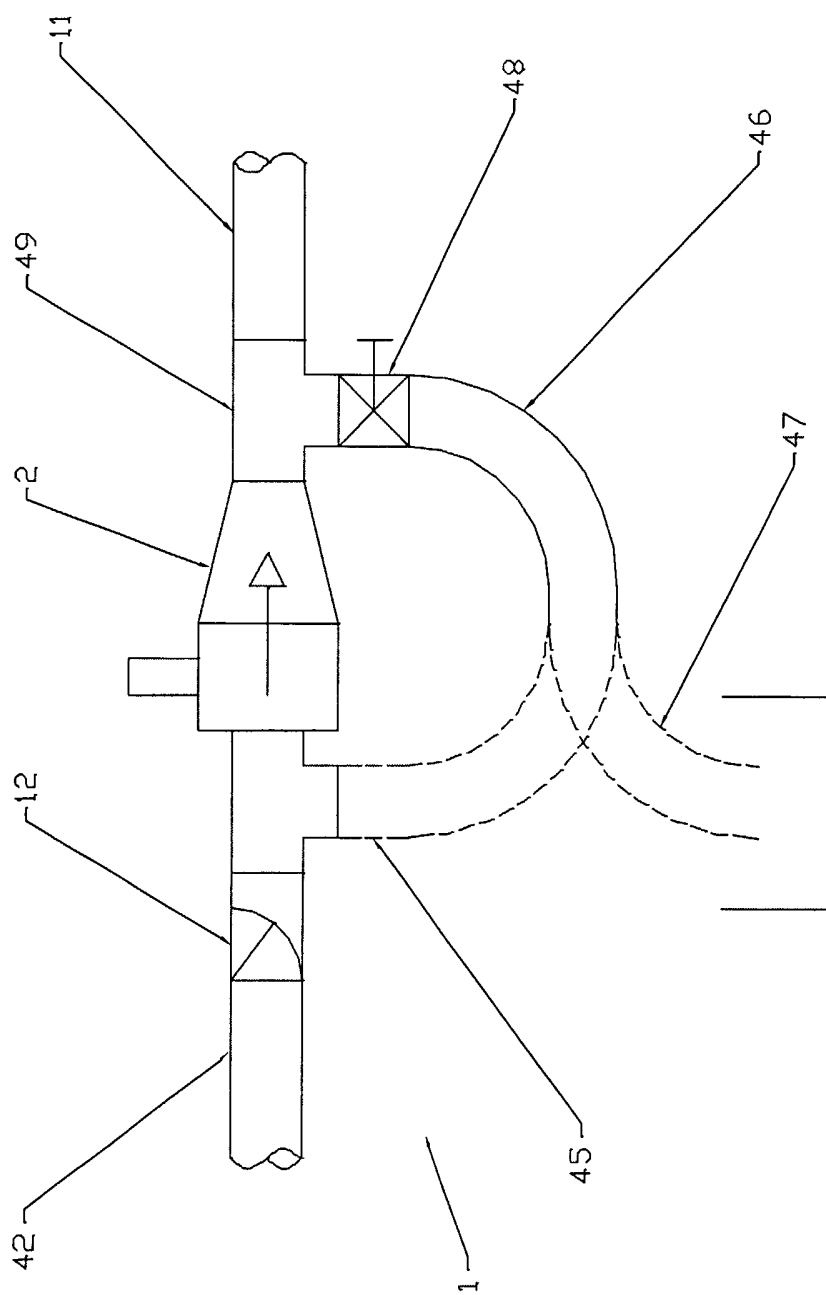

Figure 8

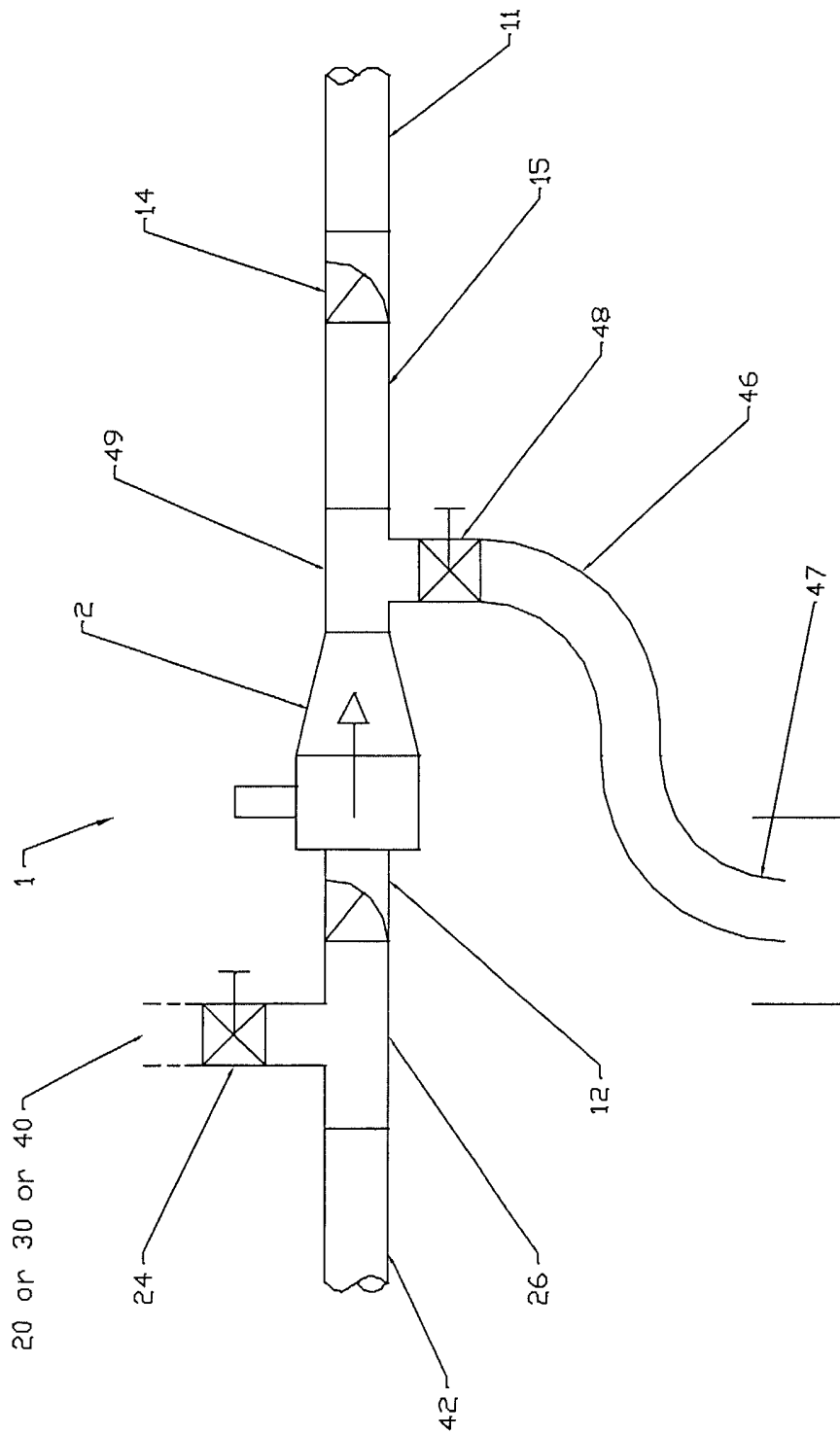

Figure 9

INTERNATIONAL SEARCH REPORT

PCT/GB 03/05552

| | | | | |
|--|---|--|---|---|
| A. CLASSIFICATION OF SUBJECT MATTER IPC 7 F04F5/54 F04F5/24 F04F5/48 | | | | |
| According to International Patent Classification (IPC) or to both national classification and IPC | | | | |
| B. FIELDS SEARCHED | | | | |
| Minimum documentation searched (classification system followed by classification symbols) IPC 7 F04F | | | | |
| Documentation searched other than minimum documentation to the extent that such documents are included in the fields searched | | | | |
| Electronic data base consulted during the international search (name of data base and, where practical, search terms used) EPO-Internal, PAJ, WPI Data | | | | |
| C. DOCUMENTS CONSIDERED TO BE RELEVANT | | | | |
| Category ° | Citation of document, with indication, where appropriate, of the relevant passages | Relevant to claim No. | | |
| Y | US 3 664 768 A (MAYS JOHN C ET AL) 23 May 1972 (1972-05-23) abstract column 3, line 23 -column 4, line 25 figures 1,4 --- | 1-5, 11-14, 24,25 | | |
| Y | US 4 725 201 A (NICODEMUS CARL D) 16 February 1988 (1988-02-16) abstract column 2, line 13 -column 3, line 51 figure 1 --- -/-- | 1-5, 11-14, 24,25 | | |
| <table style="width: 100%; border: none;"> <tr> <td style="width: 50%; border: none;"><input checked="" type="checkbox"/> Further documents are listed in the continuation of box C.</td> <td style="width: 50%; border: none;"><input checked="" type="checkbox"/> Patent family members are listed in annex.</td> </tr> </table> | | | <input checked="" type="checkbox"/> Further documents are listed in the continuation of box C. | <input checked="" type="checkbox"/> Patent family members are listed in annex. |
| <input checked="" type="checkbox"/> Further documents are listed in the continuation of box C. | <input checked="" type="checkbox"/> Patent family members are listed in annex. | | | |
| ° Special categories of cited documents : | | | | |
| <table style="width: 100%; border: none;"> <tr> <td style="width: 50%; border: none;"> *A* document defining the general state of the art which is not considered to be of particular relevance *E* earlier document but published on or after the international filing date *L* document which may throw doubts on priority claim(s) or which is cited to establish the publication date of another citation or other special reason (as specified) *O* document referring to an oral disclosure, use, exhibition or other means *P* document published prior to the international filing date but later than the priority date claimed </td> <td style="width: 50%; border: none;"> *T* later document published after the international filing date or priority date and not in conflict with the application but cited to understand the principle or theory underlying the invention *X* document of particular relevance; the claimed invention cannot be considered novel or cannot be considered to involve an inventive step when the document is taken alone *Y* document of particular relevance; the claimed invention cannot be considered to involve an inventive step when the document is combined with one or more other such documents, such combination being obvious to a person skilled in the art. *&* document member of the same patent family </td> </tr> </table> | | | *A* document defining the general state of the art which is not considered to be of particular relevance *E* earlier document but published on or after the international filing date *L* document which may throw doubts on priority claim(s) or which is cited to establish the publication date of another citation or other special reason (as specified) *O* document referring to an oral disclosure, use, exhibition or other means *P* document published prior to the international filing date but later than the priority date claimed | *T* later document published after the international filing date or priority date and not in conflict with the application but cited to understand the principle or theory underlying the invention *X* document of particular relevance; the claimed invention cannot be considered novel or cannot be considered to involve an inventive step when the document is taken alone *Y* document of particular relevance; the claimed invention cannot be considered to involve an inventive step when the document is combined with one or more other such documents, such combination being obvious to a person skilled in the art. *&* document member of the same patent family |
| *A* document defining the general state of the art which is not considered to be of particular relevance *E* earlier document but published on or after the international filing date *L* document which may throw doubts on priority claim(s) or which is cited to establish the publication date of another citation or other special reason (as specified) *O* document referring to an oral disclosure, use, exhibition or other means *P* document published prior to the international filing date but later than the priority date claimed | *T* later document published after the international filing date or priority date and not in conflict with the application but cited to understand the principle or theory underlying the invention *X* document of particular relevance; the claimed invention cannot be considered novel or cannot be considered to involve an inventive step when the document is taken alone *Y* document of particular relevance; the claimed invention cannot be considered to involve an inventive step when the document is combined with one or more other such documents, such combination being obvious to a person skilled in the art. *&* document member of the same patent family | | | |
| Date of the actual completion of the international search <p style="text-align: center; font-weight: bold;">26 March 2004</p> | | Date of mailing of the international search report <p style="text-align: center; font-weight: bold;">06/04/2004</p> | | |
| Name and mailing address of the ISA European Patent Office, P.B. 5818 Patentlaan 2 NL - 2280 HV Rijswijk Tel. (+31-70) 340-2040, Tx. 31 651 epo nl, Fax: (+31-70) 340-3016 | | Authorized officer <p style="text-align: center; font-weight: bold;">Kolby, L</p> | | |

INTERNATIONAL SEARCH REPORT

PCT/GB 03/05552

| C.(Continuation) DOCUMENTS CONSIDERED TO BE RELEVANT | | |
|--|---|------------------------------|
| Category * | Citation of document, with indication, where appropriate, of the relevant passages | Relevant to claim No. |
| A | EP 0 326 901 A (INTERATOM) 9 August 1989 (1989-08-09) abstract column 2, line 7 -column 3, line 20 figures ---- | 1-5, 11-13, 24,25 |
| A | US 1 415 406 A (LEIGH SCANES ARTHUR EDWIN) 9 May 1922 (1922-05-09) column 2, line 86 -column 3, line 49 figure 1 ---- | 1,2,6, 11,14, 16,24,25 |
| A | US 4 951 713 A (JORDAN FOSTER A ET AL) 28 August 1990 (1990-08-28) abstract column 3, line 52 -column 9, line 41 figures ---- | 1,2,6, 11-14, 24,25 |
| A | US 4 569 635 A (NICODEMUS CARL D) 11 February 1986 (1986-02-11) abstract column 2, line 62 -column 6, line 48 figure 1 ---- | 1,2,11, 14,15,17 |
| A | PATENT ABSTRACTS OF JAPAN vol. 0164, no. 98 (M-1325), 15 October 1992 (1992-10-15) -& JP 04 184000 A (MITSUI ENG & SHIPBUILD CO LTD), 30 June 1992 (1992-06-30) abstract; figures ----- | 1,11 |

INTERNATIONAL SEARCH REPORT

Information on patent family members

PCT/GB 03/05552

| Patent document cited in search report | A | Publication date | Patent family member(s) | Publication date |
|---|---|------------------|-------------------------|------------------|
| US 3664768 | A | 23-05-1972 | NONE | |
| <hr style="border-top: 1px dashed black;"/> | | | | |
| US 4725201 | A | 16-02-1988 | NONE | |
| <hr style="border-top: 1px dashed black;"/> | | | | |
| EP 0326901 | A | 09-08-1989 | DE 8801397 U1 | 01-06-1989 |
| | | | AT 57995 T | 15-11-1990 |
| | | | DE 58900020 D1 | 06-12-1990 |
| | | | EP 0326901 A1 | 09-08-1989 |
| <hr style="border-top: 1px dashed black;"/> | | | | |
| US 1415406 | A | 09-05-1922 | NONE | |
| <hr style="border-top: 1px dashed black;"/> | | | | |
| US 4951713 | A | 28-08-1990 | NONE | |
| <hr style="border-top: 1px dashed black;"/> | | | | |
| US 4569635 | A | 11-02-1986 | AU 3211984 A | 04-03-1985 |
| | | | CA 1224095 A1 | 14-07-1987 |
| | | | EP 0156817 A1 | 09-10-1985 |
| | | | WO 8500641 A1 | 14-02-1985 |
| | | | US 4673335 A | 16-06-1987 |
| | | | US 4545739 A | 08-10-1985 |
| <hr style="border-top: 1px dashed black;"/> | | | | |
| JP 04184000 | A | 30-06-1992 | JP 2713814 B2 | 16-02-1998 |
| <hr style="border-top: 1px dashed black;"/> | | | | |