



US00RE48228E

(19) **United States**
(12) **Reissued Patent**
Matsui

(10) **Patent Number:** **US RE48,228 E**
(45) **Date of Reissued Patent:** **Sep. 29, 2020**

(54) **METHOD FOR MANUFACTURING LENS FOR ELECTRONIC SPECTACLES, LENS FOR ELECTRONIC SPECTACLES, AND ELECTRONIC SPECTACLES**

(58) **Field of Classification Search**
CPC G02C 7/101; G02C 7/088; G02C 7/083; G02F 1/0018

(Continued)

(71) Applicant: **Panasonic Corporation**, Kadoma-shi, Osaka (JP)

(56) **References Cited**

U.S. PATENT DOCUMENTS

(72) Inventor: **Masatomo Matsui**, Saitama (JP)

5,082,355 A * 1/1992 Warszawski 359/265
5,411,792 A 5/1995 Yukinobu et al.

(73) Assignee: **MITSUI CHEMICALS, INC.**, Tokyo (JP)

(Continued)

FOREIGN PATENT DOCUMENTS

(21) Appl. No.: **14/158,551**

GB 2306691 5/1997
JP 54-074546 U 5/1979

(22) Filed: **Jan. 17, 2014**

(Continued)

Related U.S. Patent Documents

OTHER PUBLICATIONS

Reissue of:

International Search Report of PCT/JP2008/003799, dated Apr. 7, 2009.

(64) Patent No.: **8,096,653**
Issued: **Jan. 17, 2012**
Appl. No.: **12/809,790**
PCT Filed: **Dec. 17, 2008**
PCT No.: **PCT/JP2008/003799**
§ 371 (c)(1),
(2) Date: **Jun. 21, 2010**
PCT Pub. No.: **WO2009/081542**
PCT Pub. Date: **Jul. 2, 2009**

Primary Examiner — Anjan K Deb
(74) *Attorney, Agent, or Firm* — Hamre, Schumann, Mueller & Larson, P.C.

(30) **Foreign Application Priority Data**

(57) **ABSTRACT**

Dec. 21, 2007 (JP) 2007-329719

A first recess (102) of a lower substrate (100) is coated with conductive ink to form a first auxiliary electrode layer (104), a lower electrode pattern (105) is formed thereon by vacuum deposition, a second recess (202) of an upper substrate (200) is coated with the conductive ink to form a second auxiliary electrode layer (204), an upper electrode pattern (205) is formed thereon by vacuum deposition, the upper and lower substrates are bonded to each other with an electric element (300) interposed between the lower substrate (100) and the upper substrate (100), and the upper and lower substrates are cut at positions on the overlap portion of the first auxiliary electrode layer (104) and the lower electrode pattern (105) and the overlap portion of the second auxiliary electrode layer (204) and the upper electrode pattern (205) so as to expose the cut surfaces of the substrates.

(51) **Int. Cl.**
G02C 7/02 (2006.01)
G02C 13/00 (2006.01)
(Continued)

(52) **U.S. Cl.**
CPC **G02C 5/00** (2013.01); **B29D 11/00634** (2013.01); **B29D 11/00817** (2013.01);
(Continued)

14 Claims, 33 Drawing Sheets

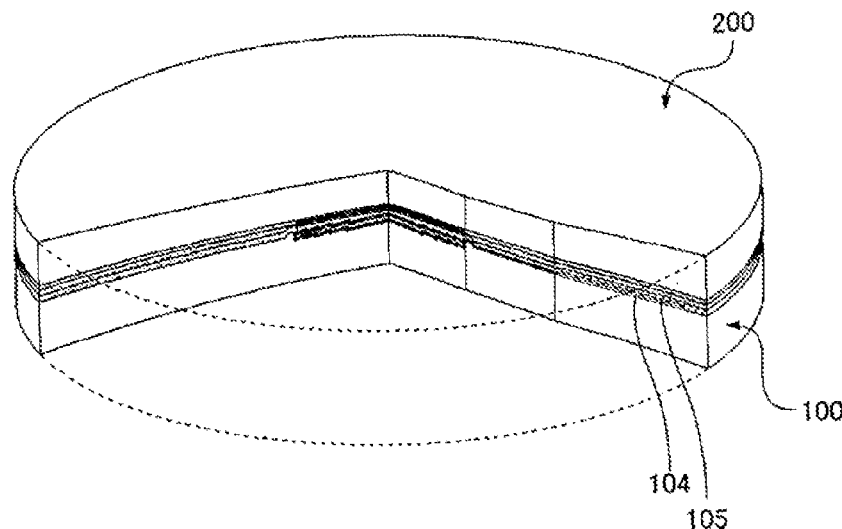

US RE48,228 E

- | | | |
|------|---|---|
| (51) | <p>Int. Cl.
 G02C 5/00 (2006.01)
 B29D 11/00 (2006.01)
 G02C 7/10 (2006.01)
 G02F 1/1345 (2006.01)
 G02C 7/08 (2006.01)</p> | <p>2007/0153356 A1 7/2007 McCabe et al.
 2007/0296918 A1 12/2007 Blum et al.
 2009/0201461 A1 8/2009 Kosa et al.
 2009/0251660 A1 10/2009 Figler et al.
 2009/0256977 A1 10/2009 Haddock et al.
 2010/0128188 A1* 5/2010 Choi et al. 349/15
 2010/0163754 A1* 7/2010 Van Herpen B32B 17/10036
 250/492.1</p> |
| (52) | <p>U.S. Cl.
 CPC G02C 7/02 (2013.01); G02C 7/083
 (2013.01); G02C 7/088 (2013.01); G02C
 7/101 (2013.01); G02F 1/1345 (2013.01);
 Y10T 29/49155 (2015.01)</p> | <p>2010/0177277 A1 7/2010 Kokonaski et al.
 2012/0075575 A1 3/2012 Matsui
 2012/0075576 A1 3/2012 Matsui
 2012/0075578 A1 3/2012 Matsui
 2012/0081659 A1 4/2012 Matsui
 2012/0154741 A1 6/2012 Sone et al.</p> |
| (58) | <p>Field of Classification Search
 USPC 351/159.03, 159.39; 359/254, 269, 271
 See application file for complete search history.</p> | |

FOREIGN PATENT DOCUMENTS

- | | | |
|------|--|---|
| (56) | <p align="center">References Cited</p> <p align="center">U.S. PATENT DOCUMENTS</p> <p>5,538,789 A * 7/1996 Capote B23K 35/0222
 252/512</p> <p>5,777,714 A 7/1998 Conway
 5,835,185 A * 11/1998 Kallman et al. 351/113
 5,995,271 A * 11/1999 Zieba et al. 359/265
 6,404,476 B1 6/2002 Mase
 6,491,394 B1 * 12/2002 Blum et al. 351/228
 7,052,290 B1 * 5/2006 Thornton 439/91
 7,290,875 B2 * 11/2007 Blum et al. 351/159
 7,297,627 B2 * 11/2007 Shah et al. 438/622
 7,425,066 B2 * 9/2008 Blum et al. 351/159.39
 7,632,540 B2 * 12/2009 Kumar et al. 427/162
 7,775,660 B2 * 8/2010 Stewart et al. 351/159.44
 8,096,653 B2 1/2012 Matsui
 2004/0084790 A1 5/2004 Blum et al.
 2004/0101232 A1 * 5/2004 Zhang et al. 385/16
 2005/0185135 A1 8/2005 Blum et al.
 2006/0056003 A1 3/2006 Tonar et al.
 2006/0273302 A1 * 12/2006 Birau et al. 257/40</p> | <p>JP 61-177428 8/1986
 JP 1-88927 6/1989
 JP 1-88927 U 6/1989
 JP 2-30921 2/1990
 JP 2-30921 U 2/1990
 JP 02-132210 U 11/1990
 JP 02-138720 U 11/1990
 JP 03-005135 U 1/1991
 JP 03-005136 U 1/1991
 JP 03-035521 U 4/1991
 JP 3-45515 4/1991
 JP 3-279914 12/1991
 JP 04231972 A * 8/1992 B32B 17/10036
 JP 07-209677 8/1995
 JP 2003-152401 5/2003
 JP 2005-519684 7/2005
 JP 2007-004083 1/2007
 WO WO 95/19588 7/1995
 WO WO 03/034138 4/2003
 WO WO 3032066 A1 * 4/2003 G02F 1/1347
 WO WO 03/077012 9/2003</p> |
|------|--|---|

* cited by examiner

FIG. 1

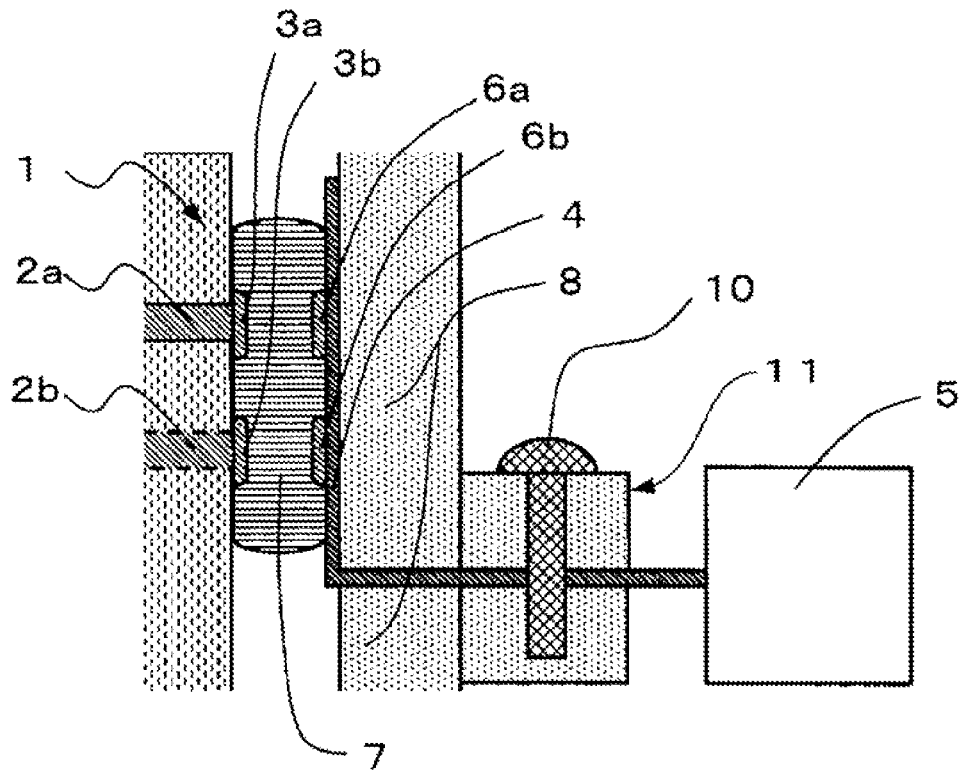

FIG. 2

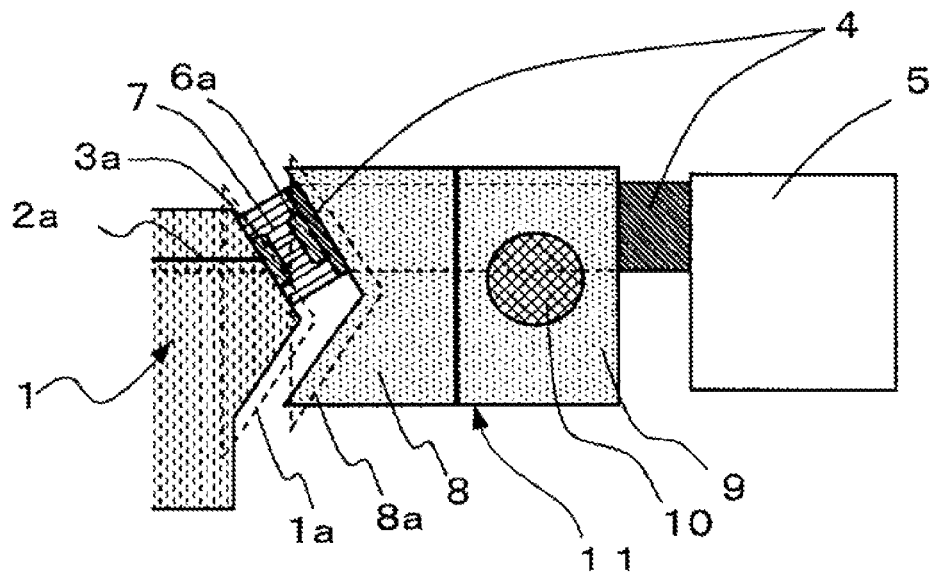

FIG. 3

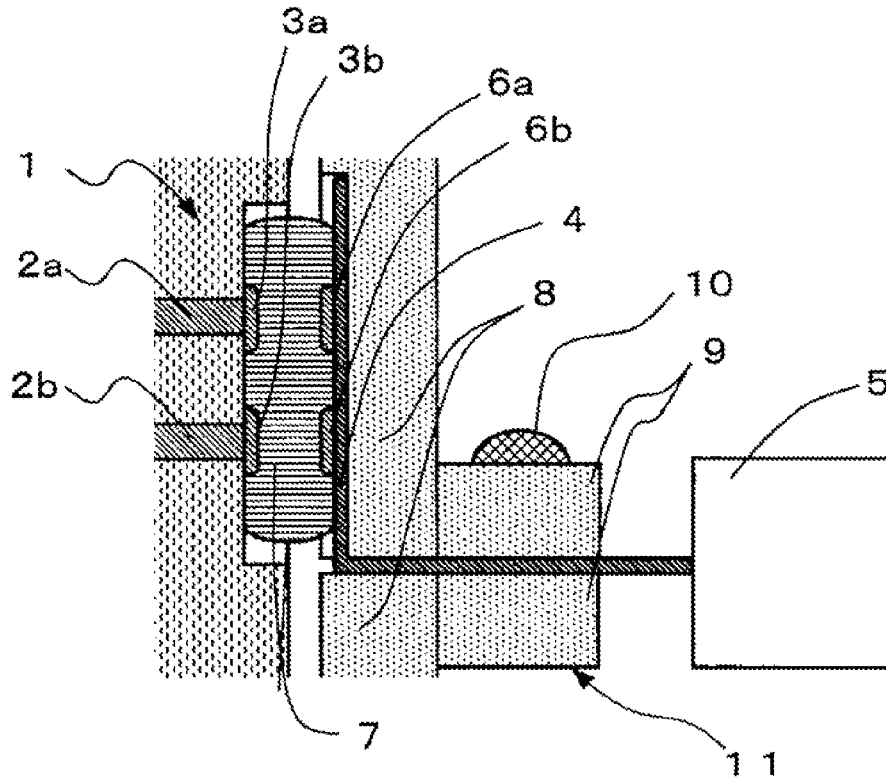

FIG. 4

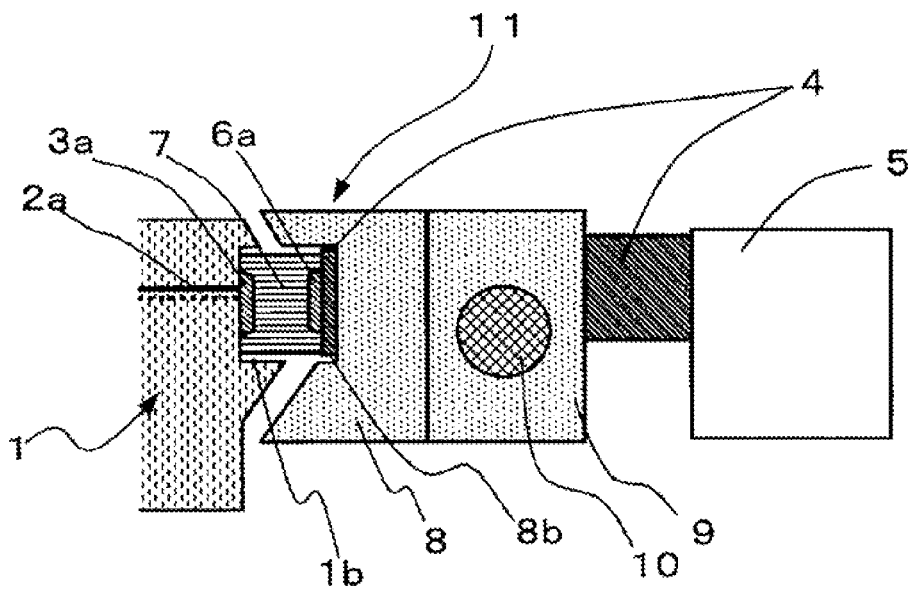
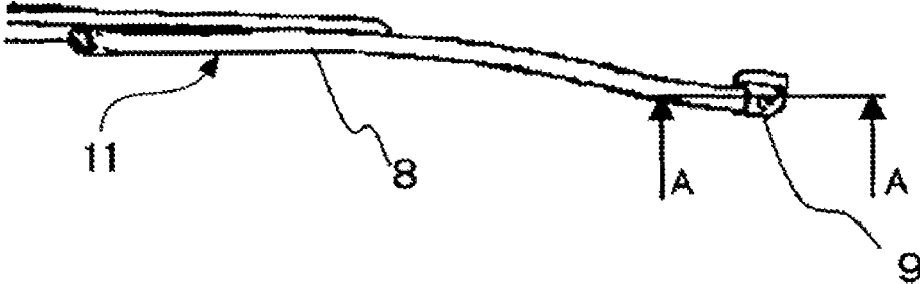

FIG. 5

(a)



(b)

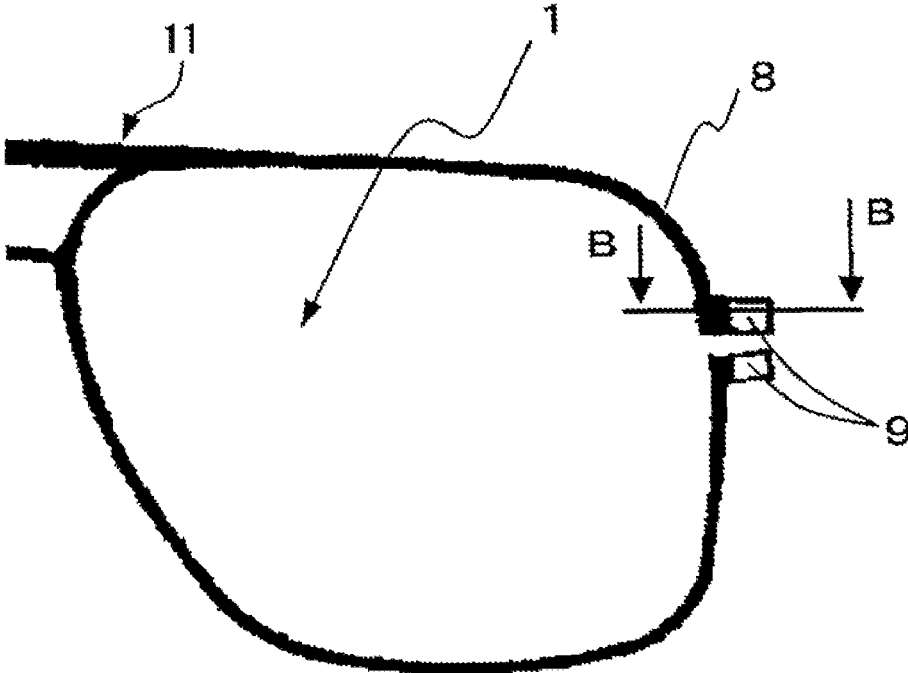

FIG. 6

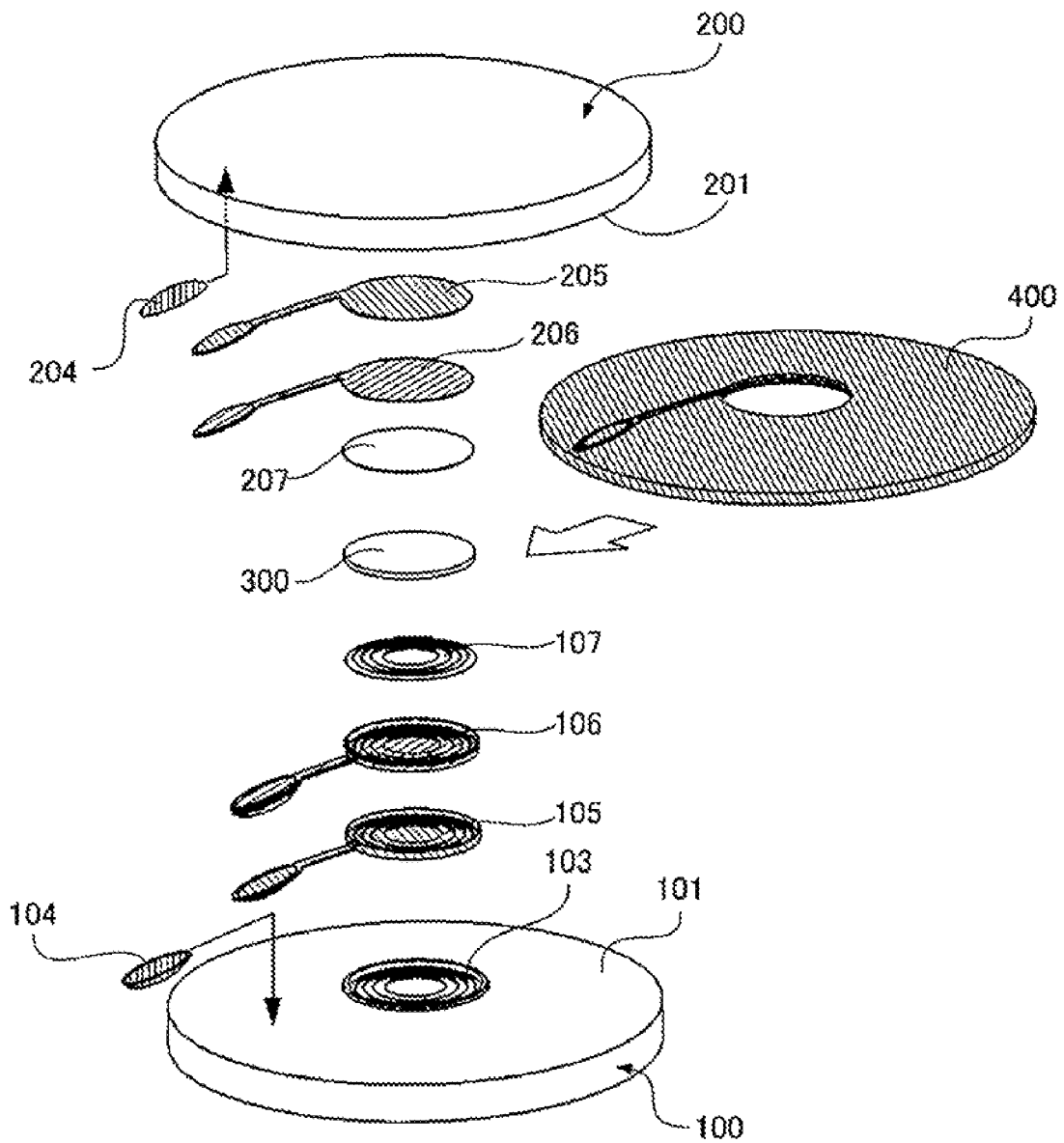

FIG. 7

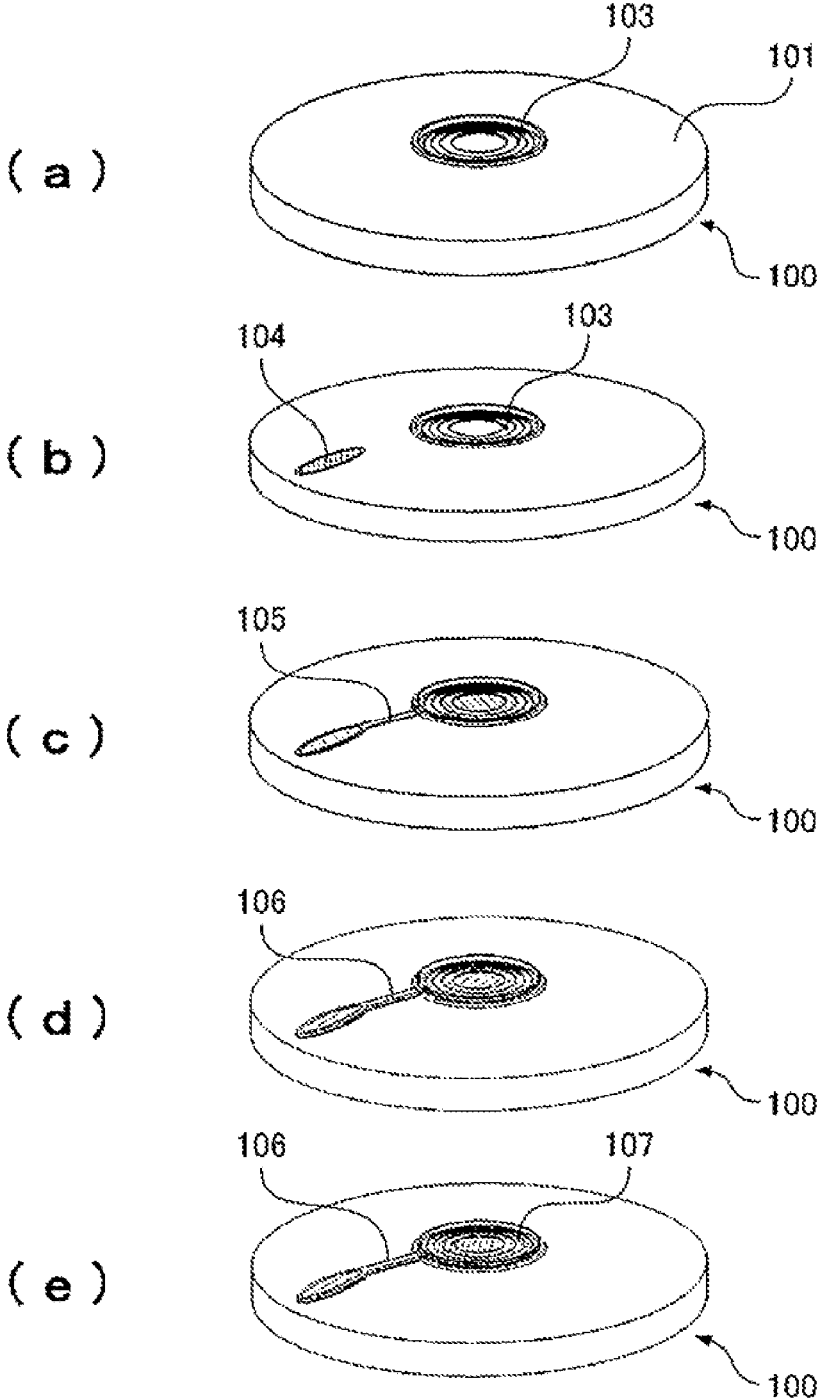

FIG. 8

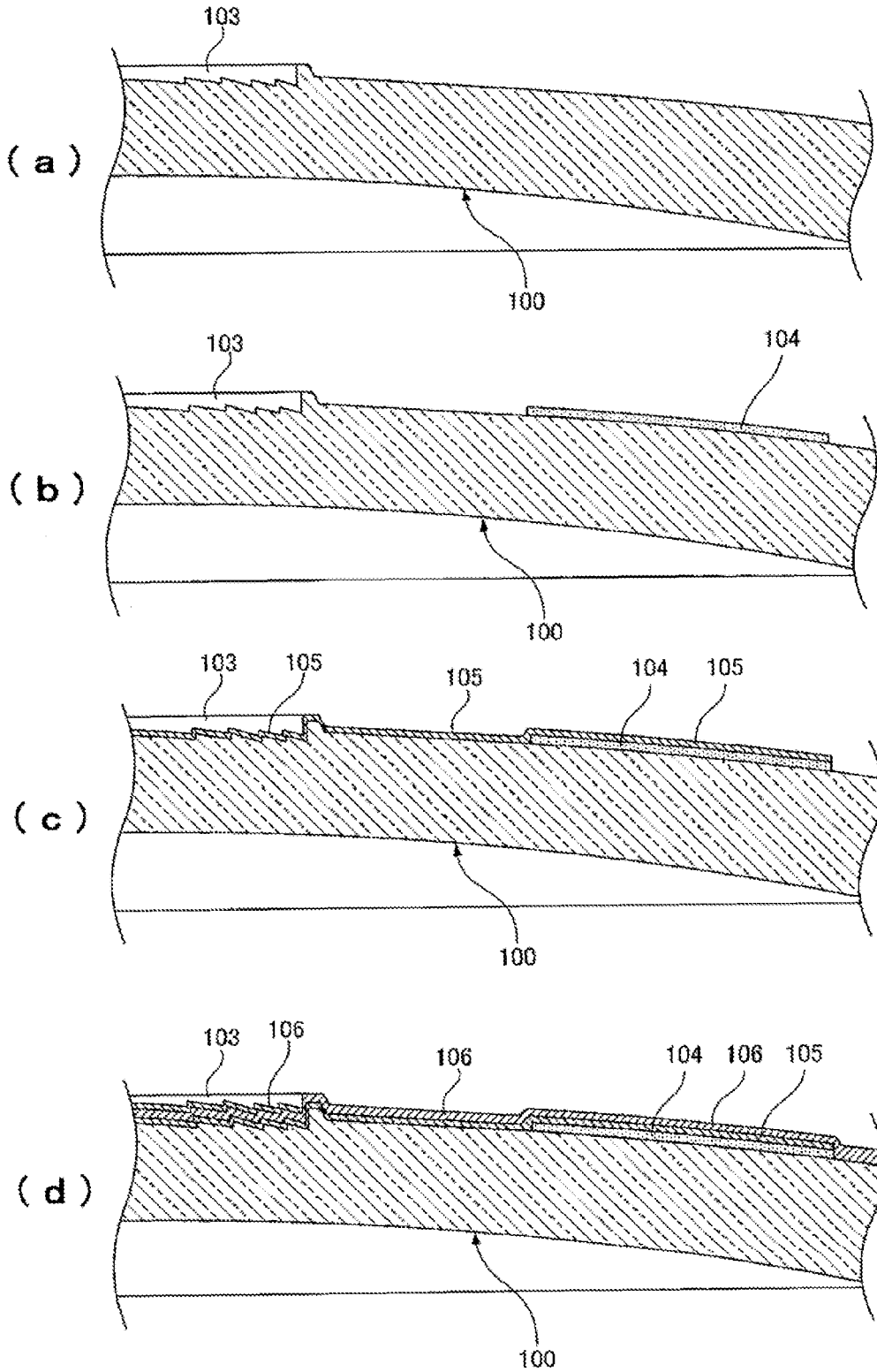

FIG. 9

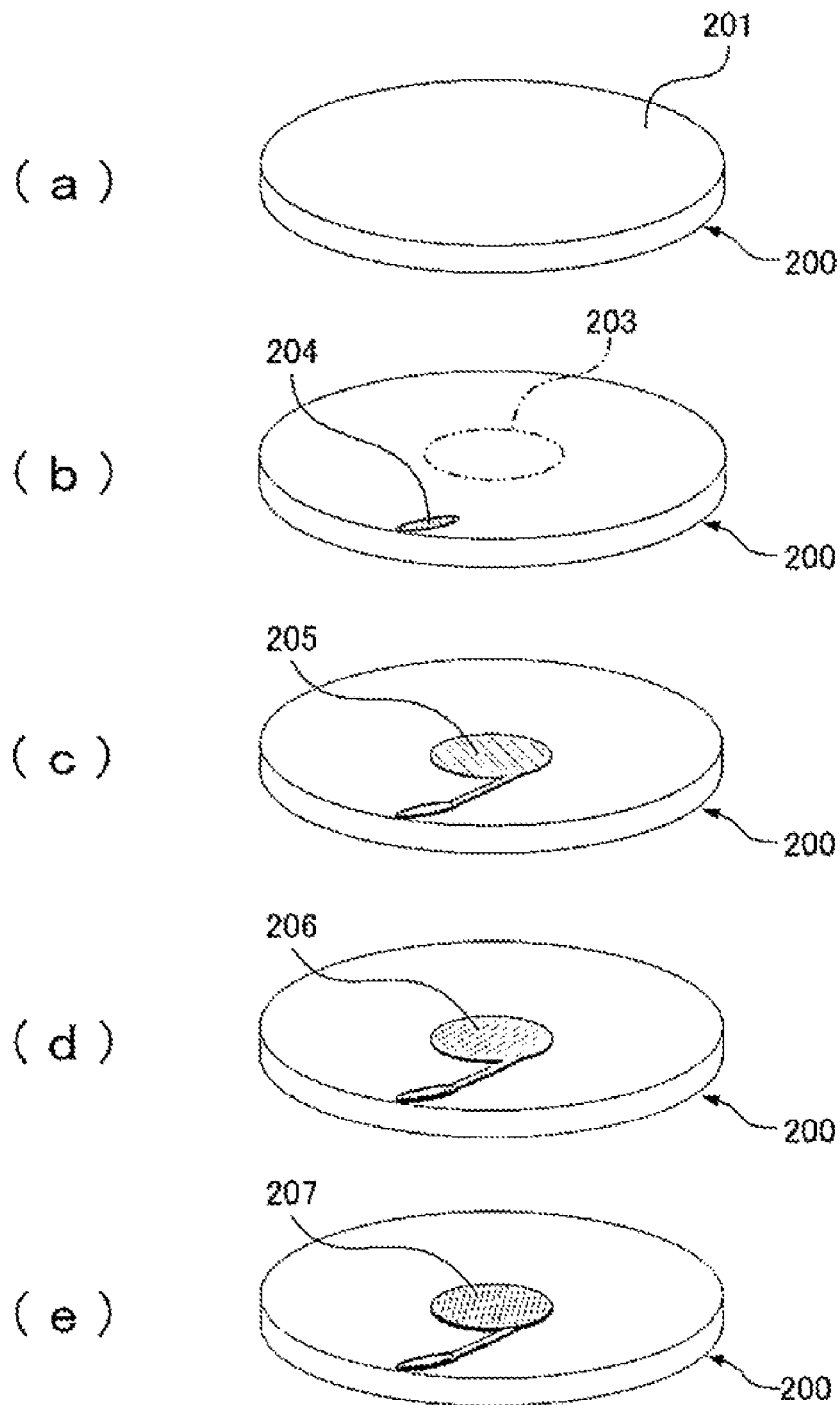

FIG. 10

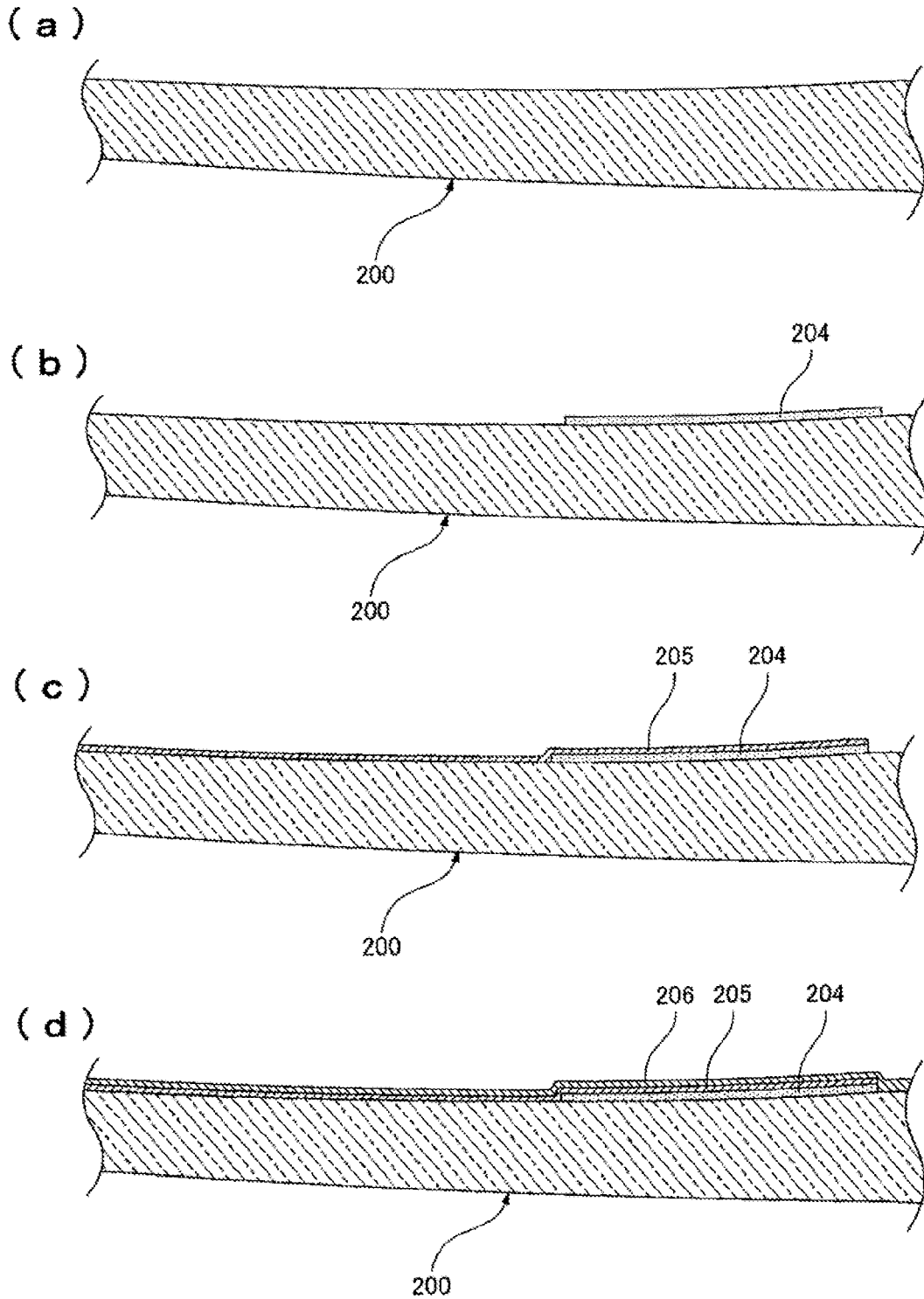

FIG. 11

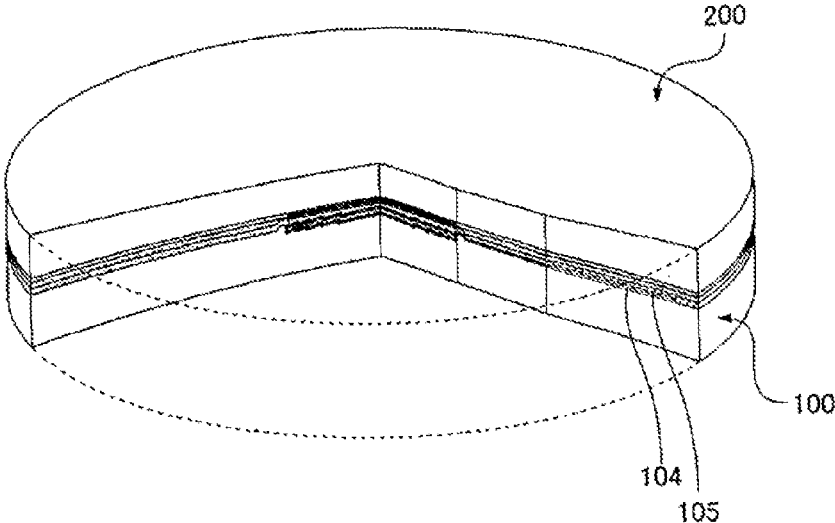

FIG. 12

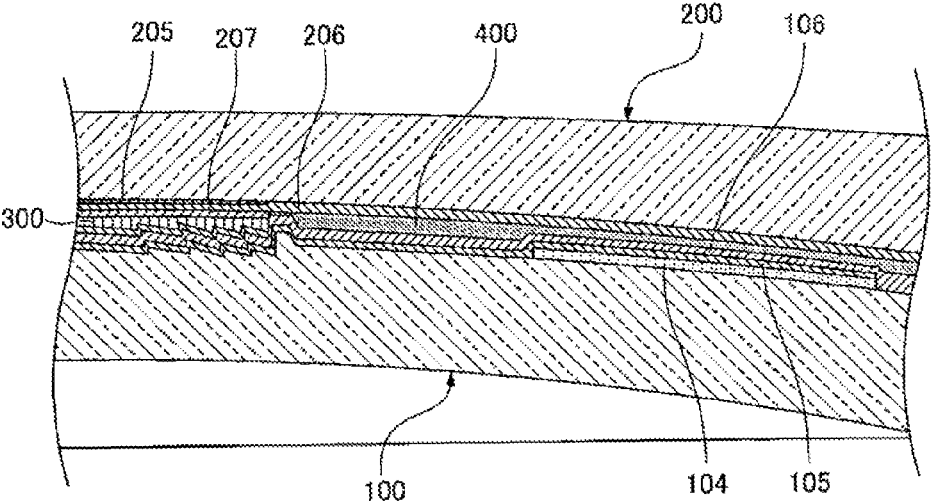

FIG. 13

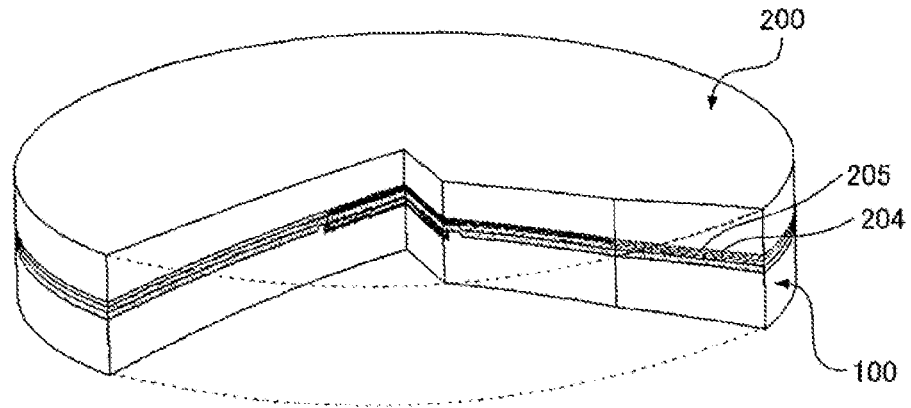

FIG. 14

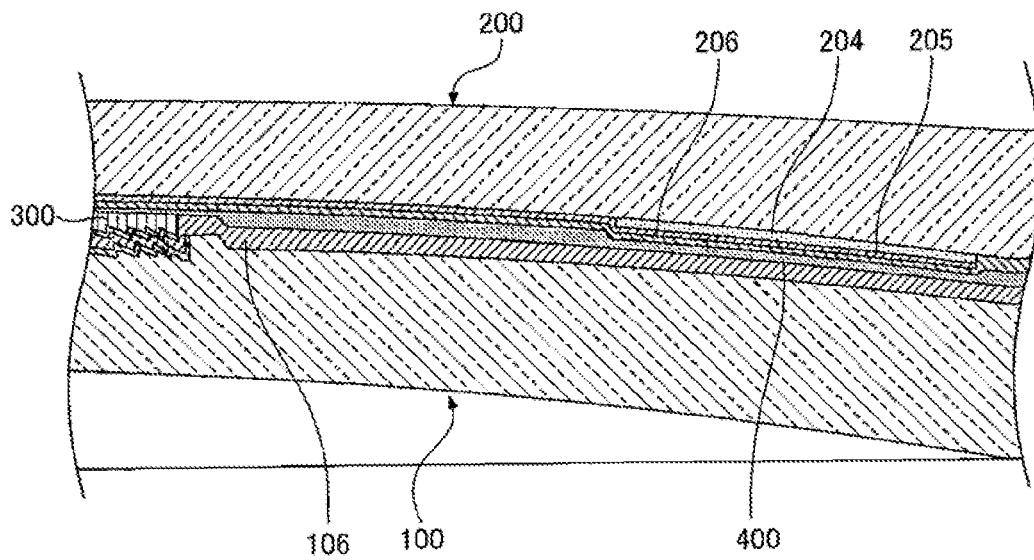

FIG. 15

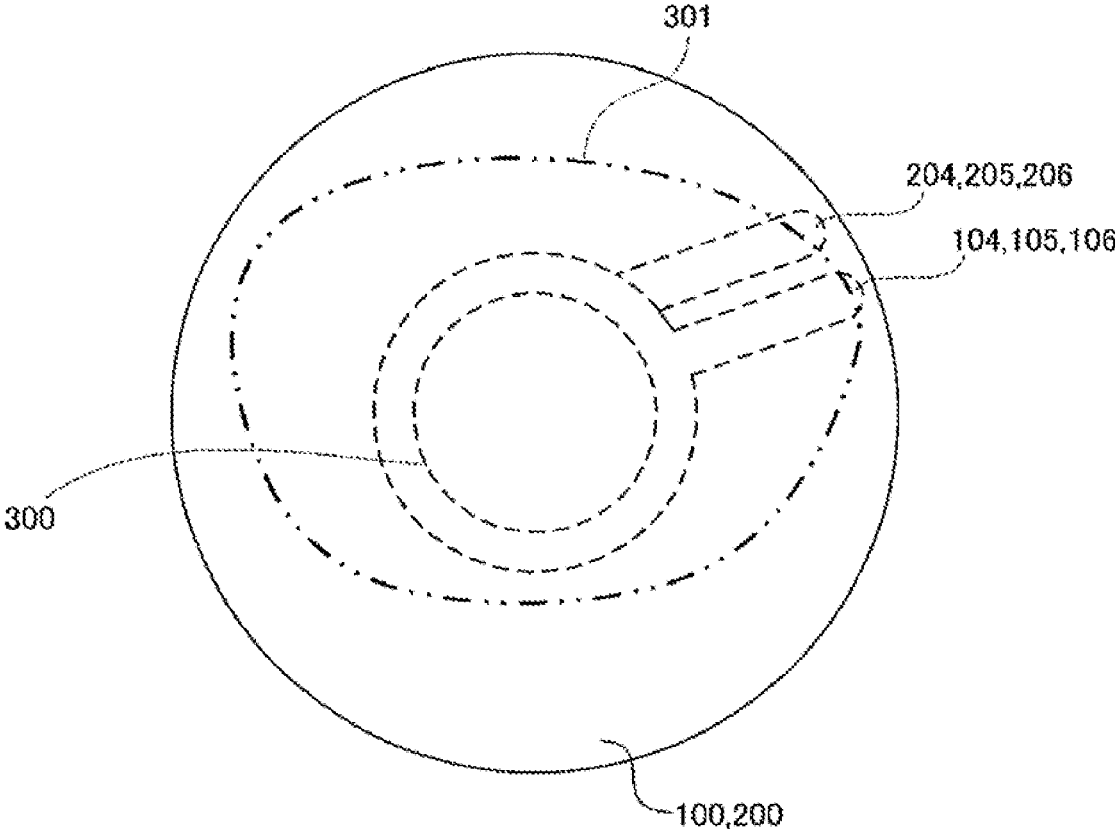

FIG. 16

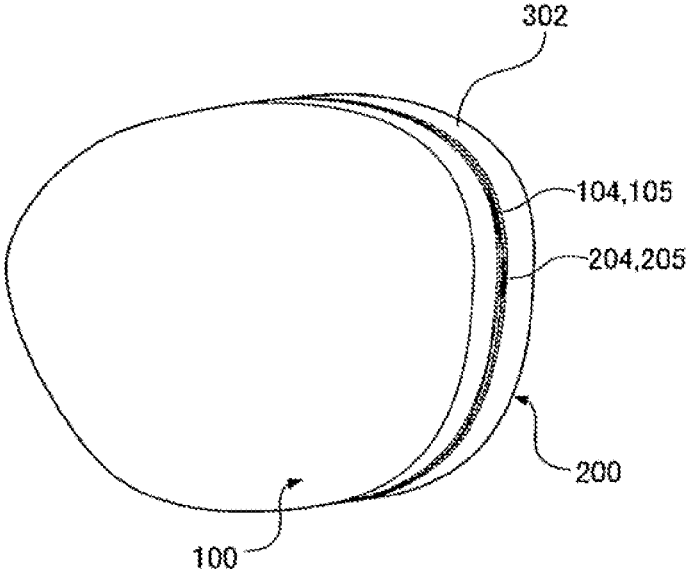

FIG. 17

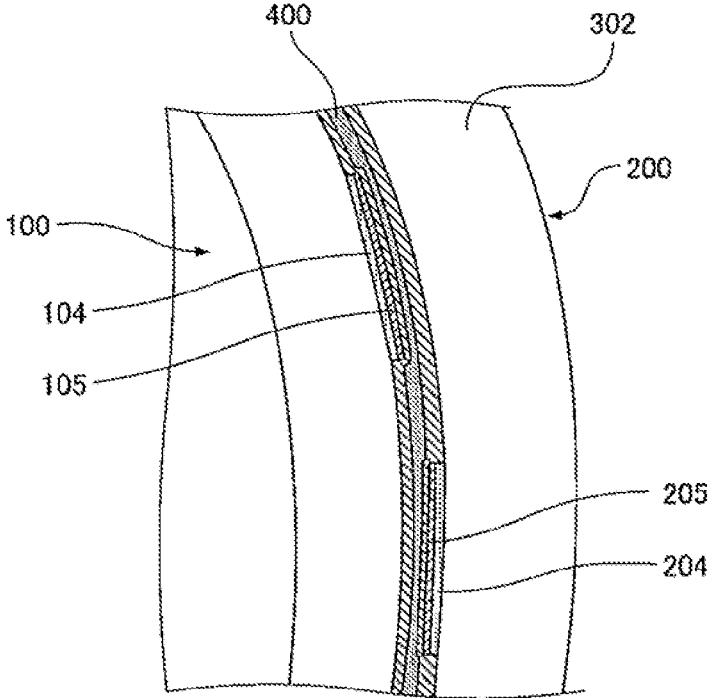

FIG. 18

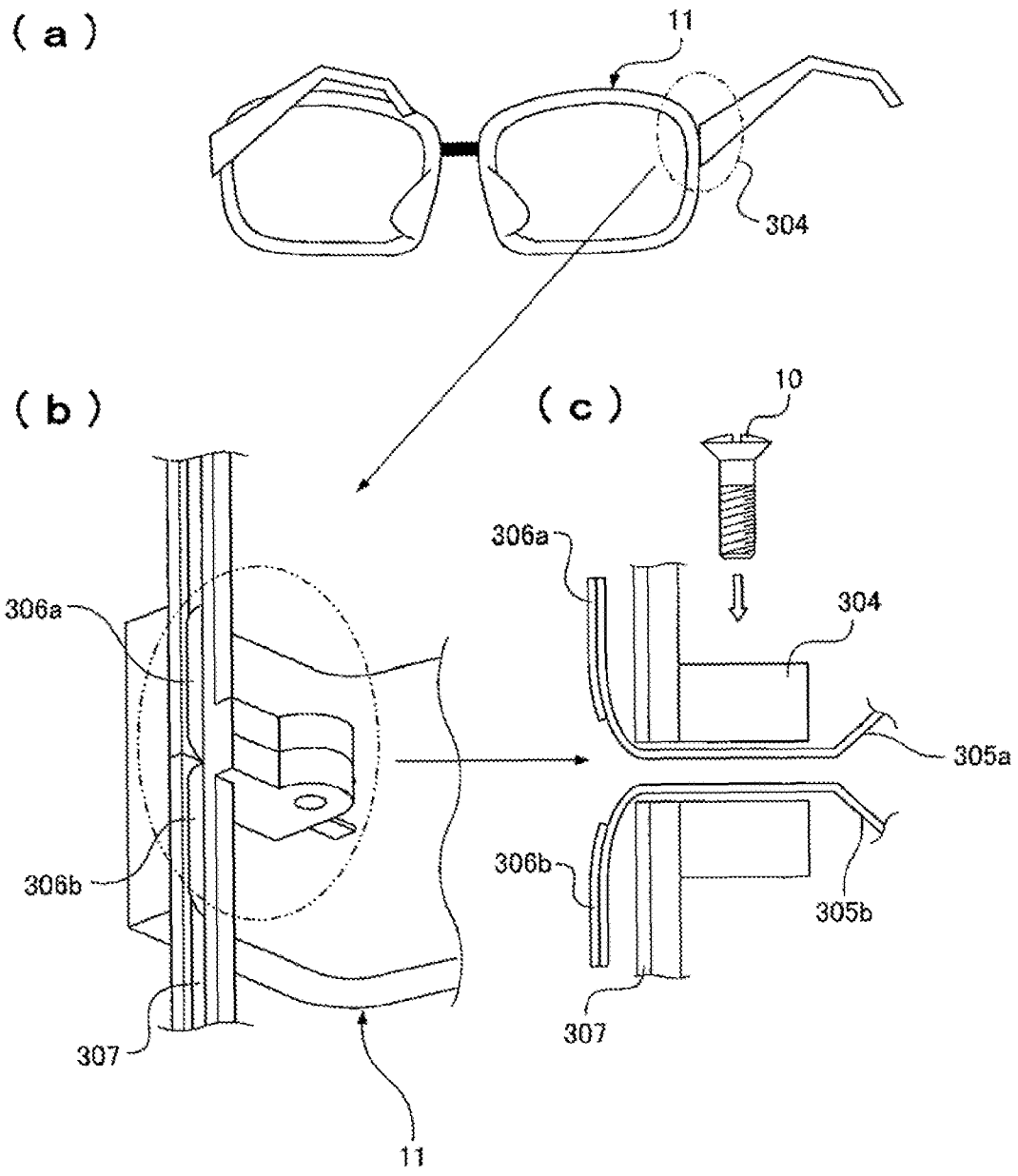

FIG. 19

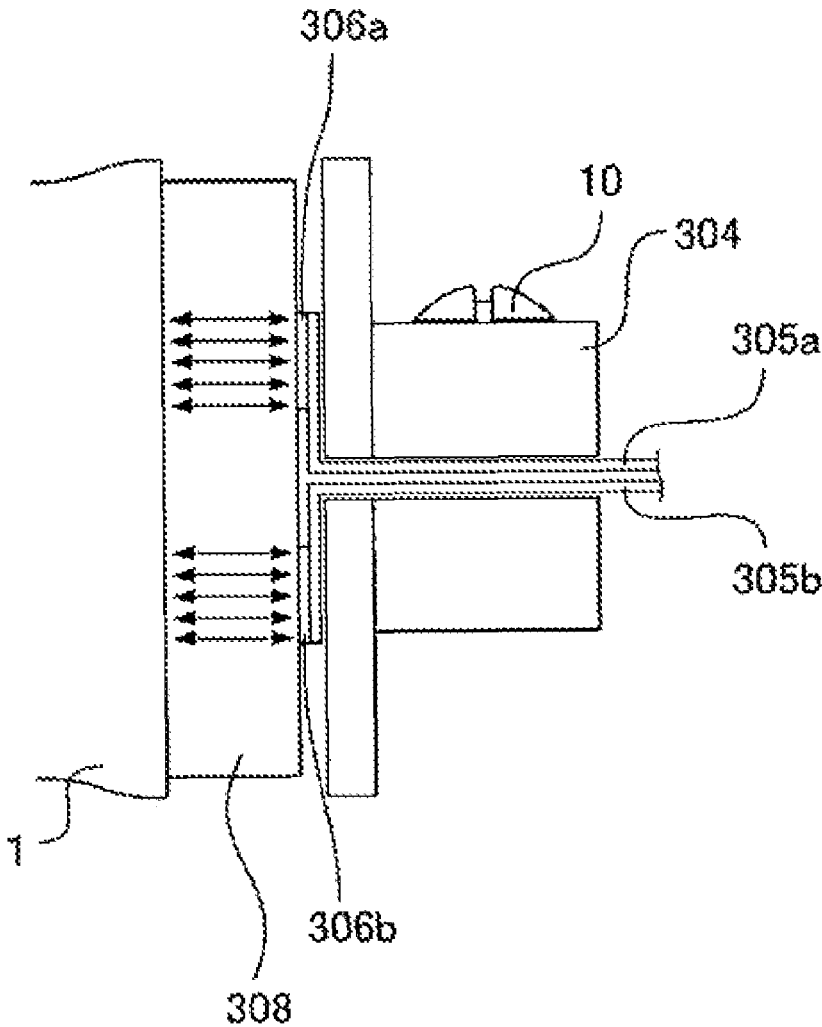

FIG. 20

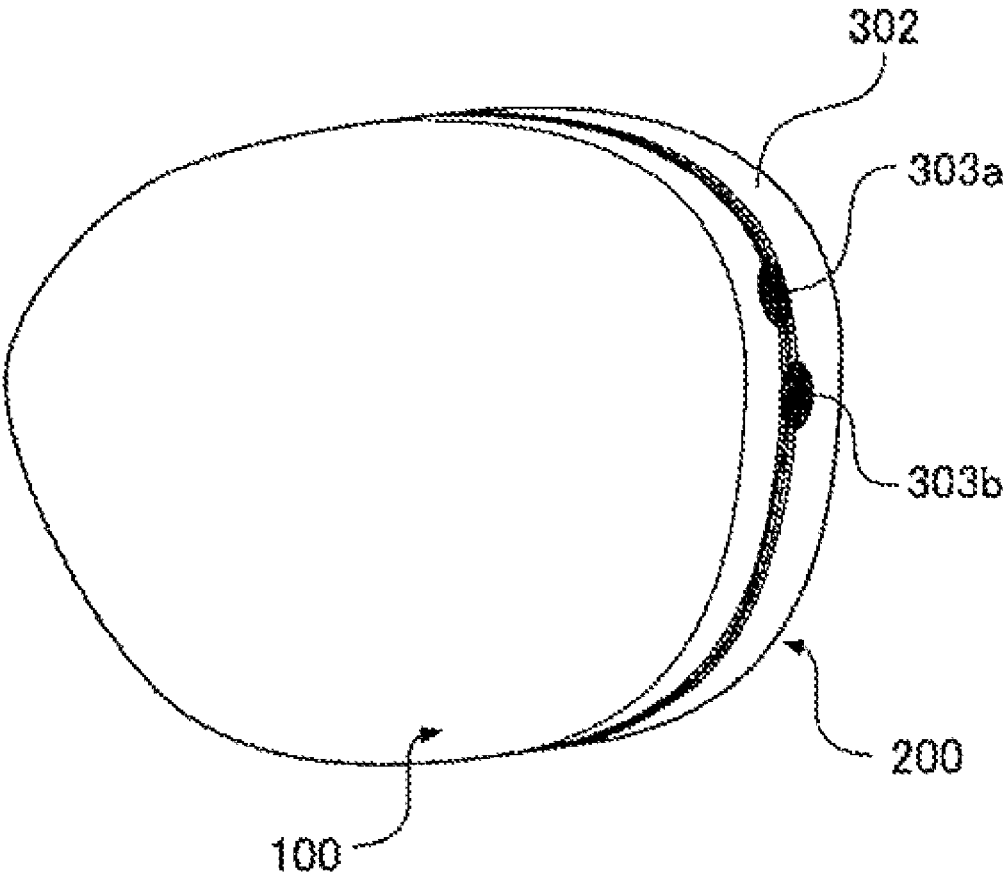

FIG. 21

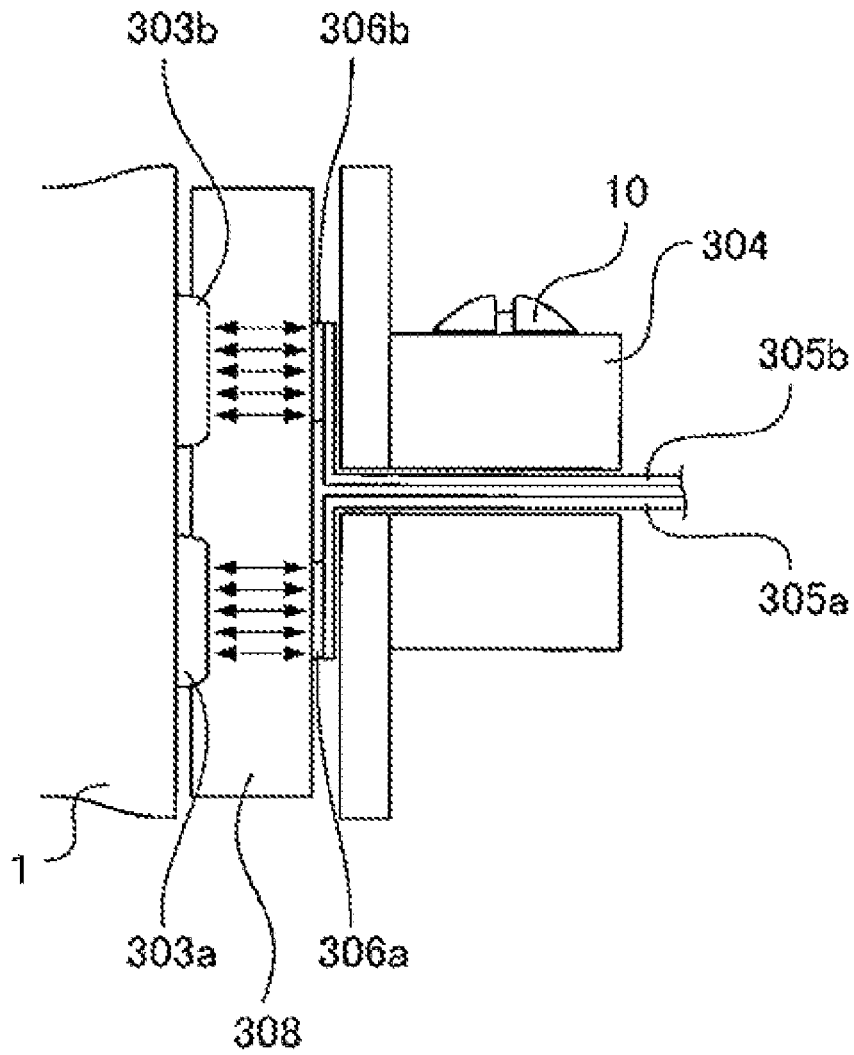

FIG. 22

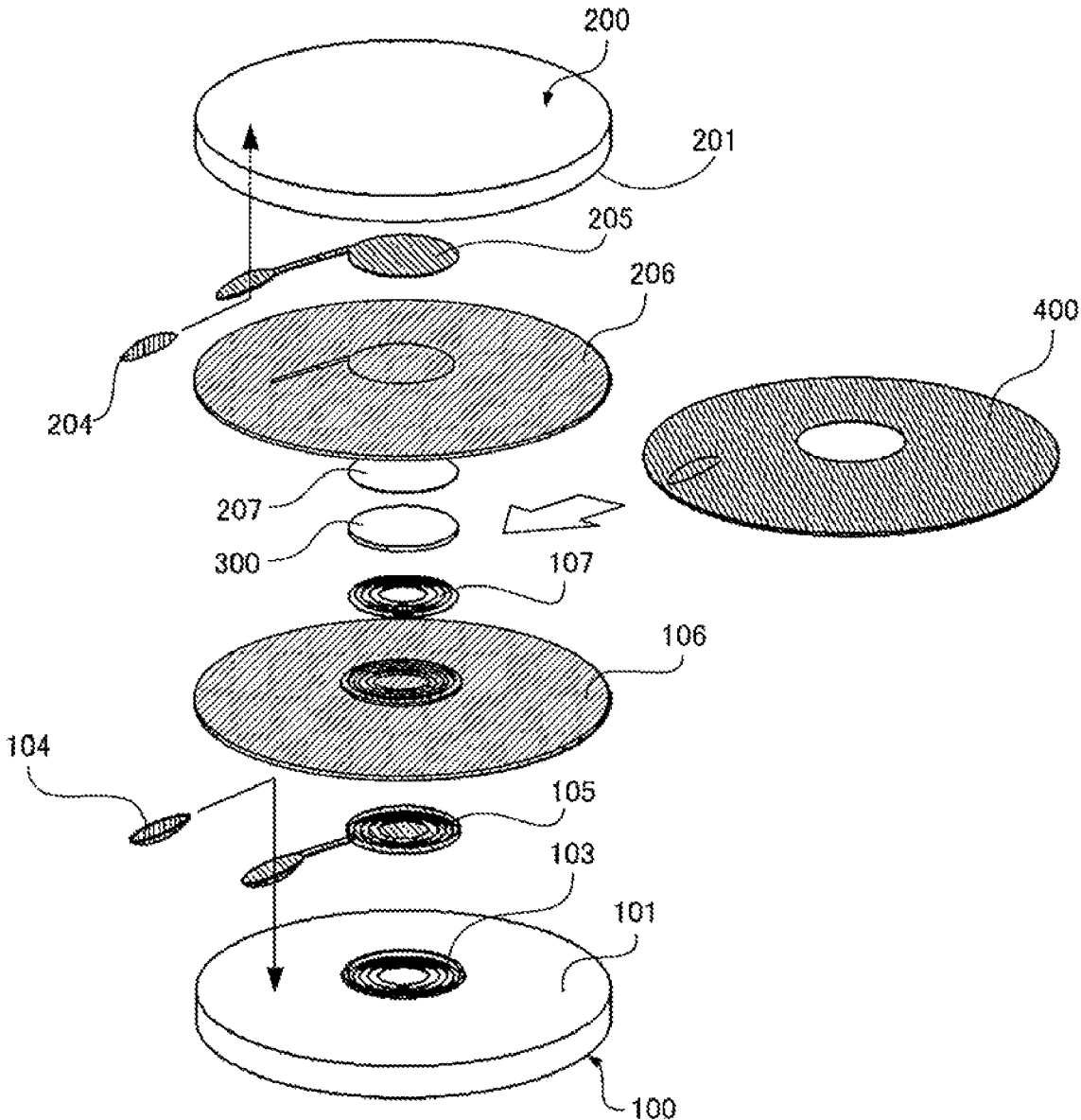

FIG. 23

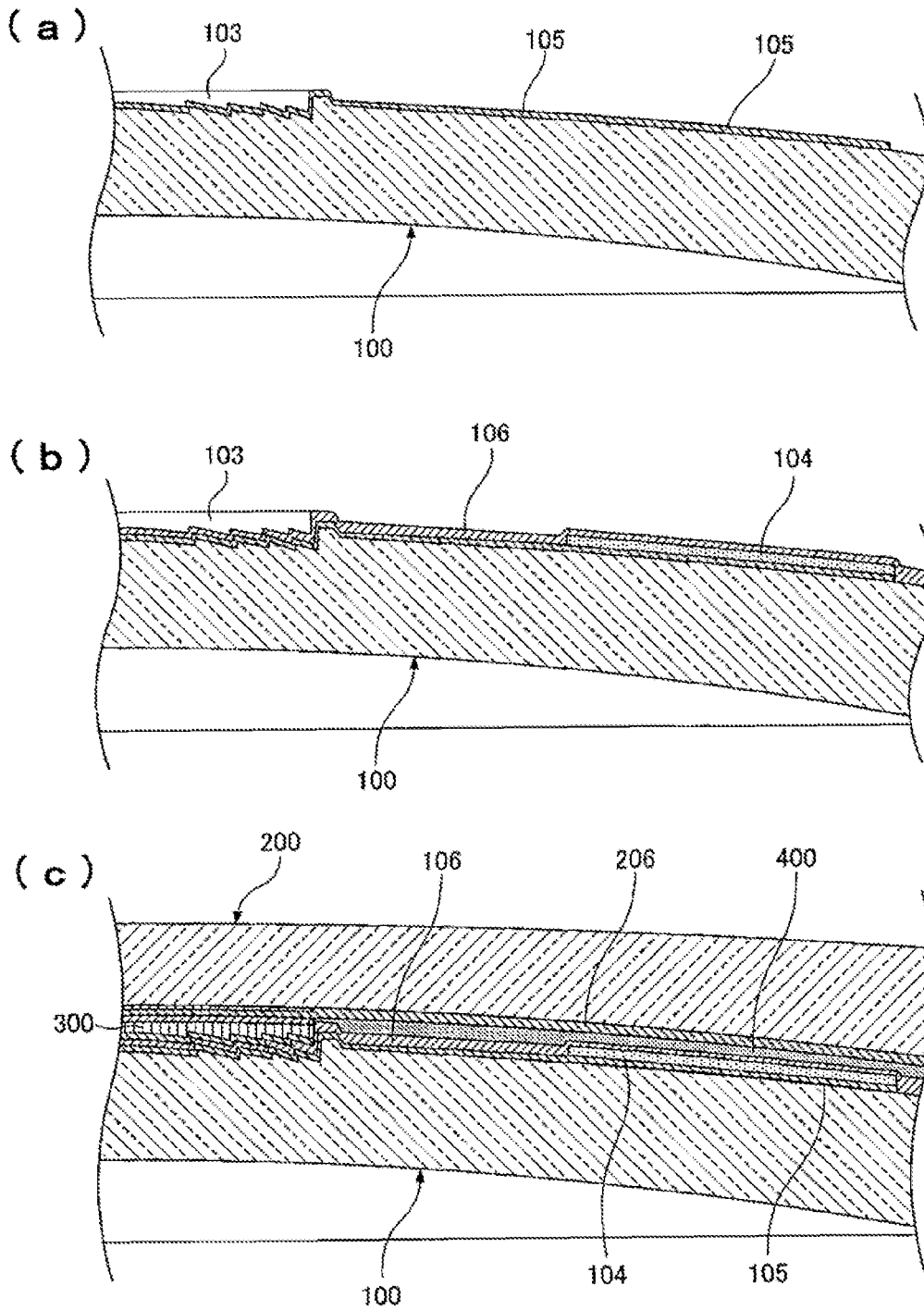

FIG. 24

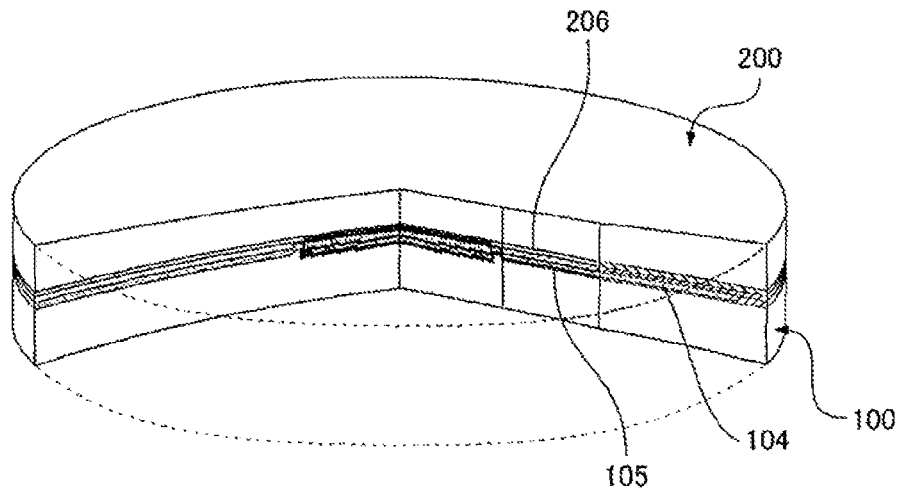

FIG. 25

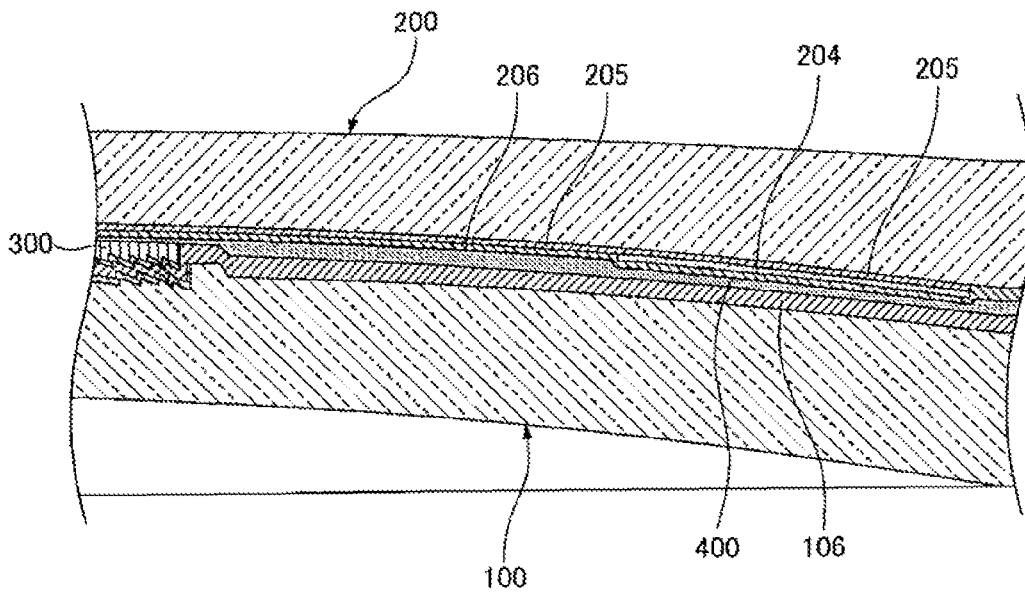

FIG. 26

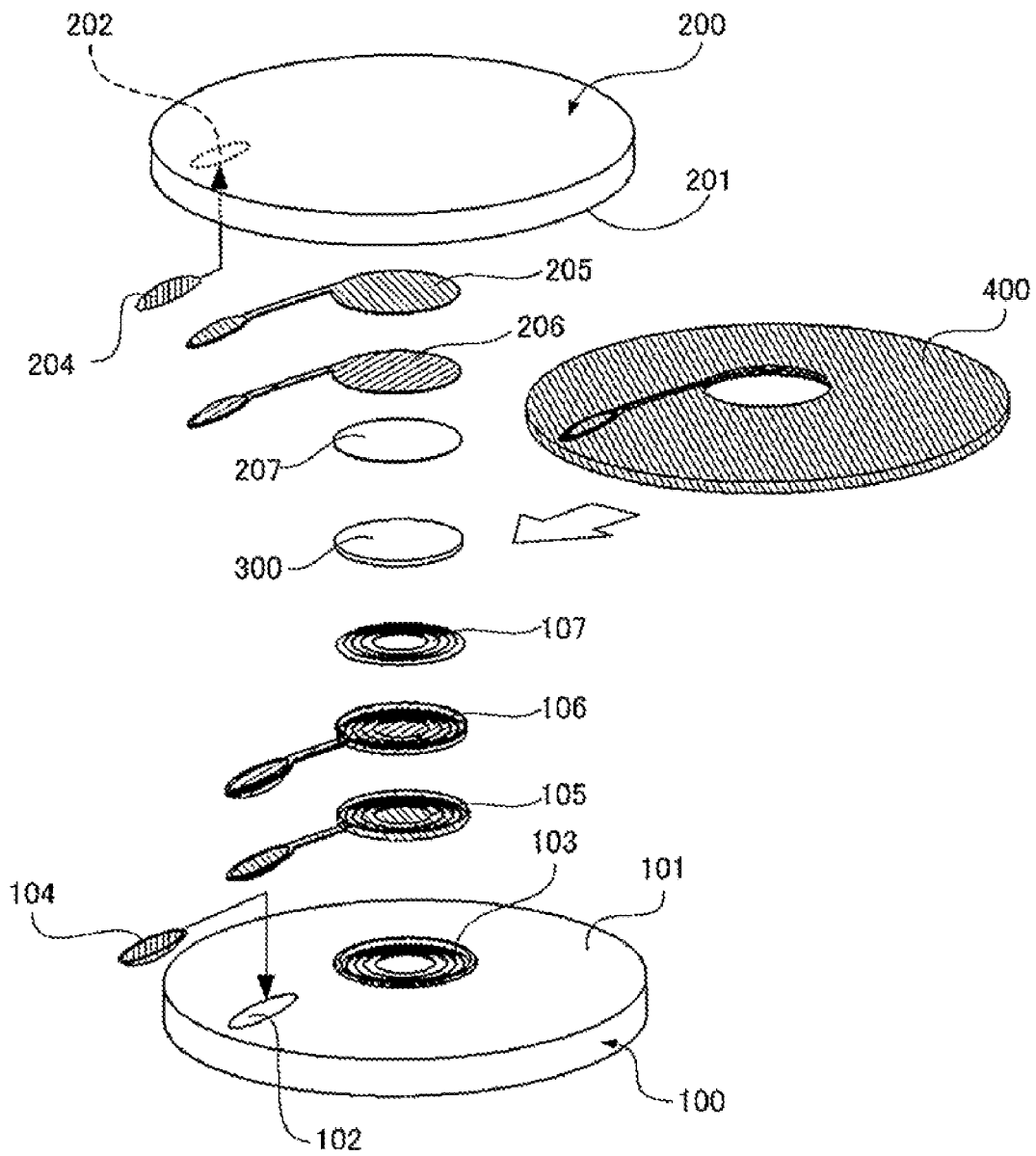

FIG. 27

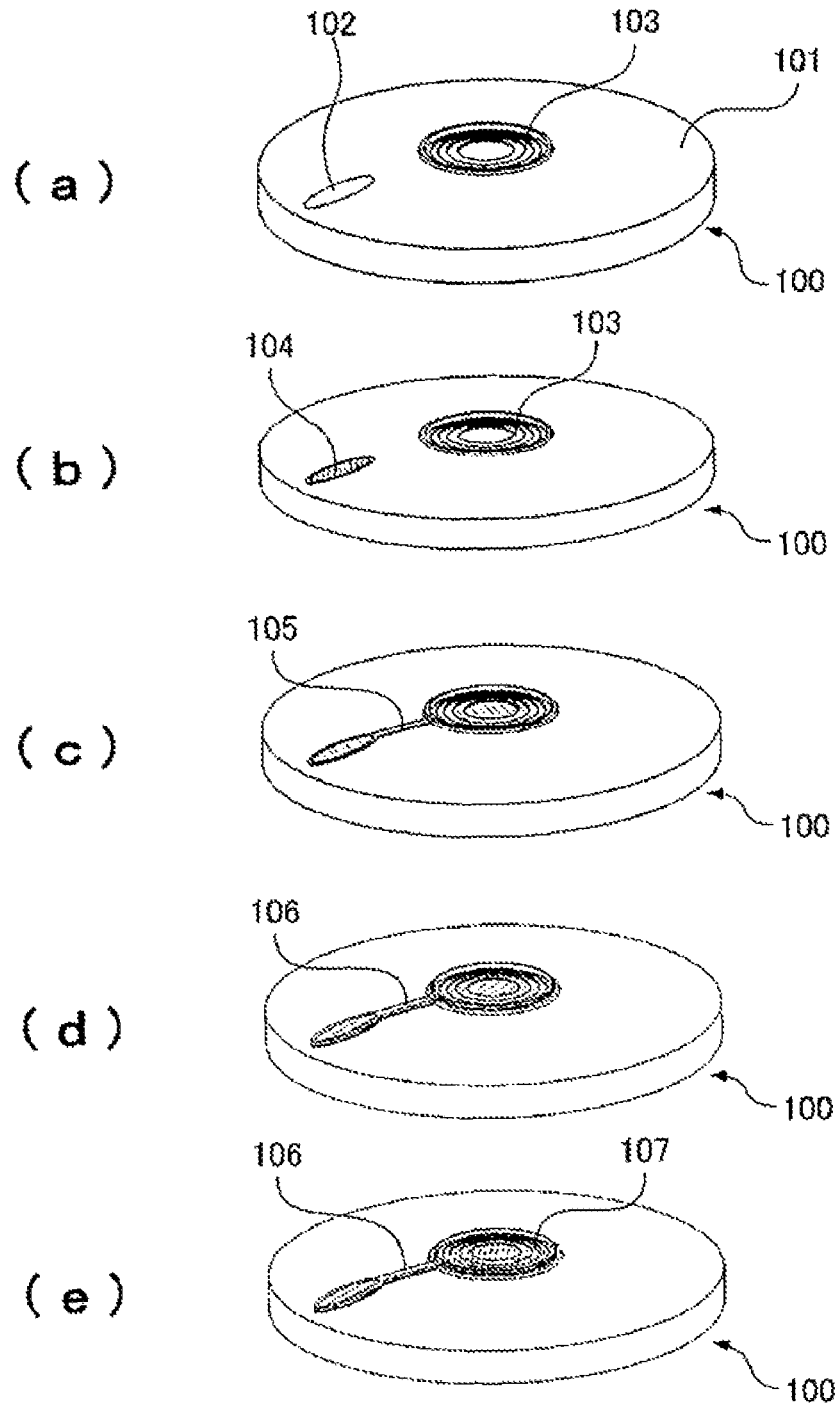

FIG. 28

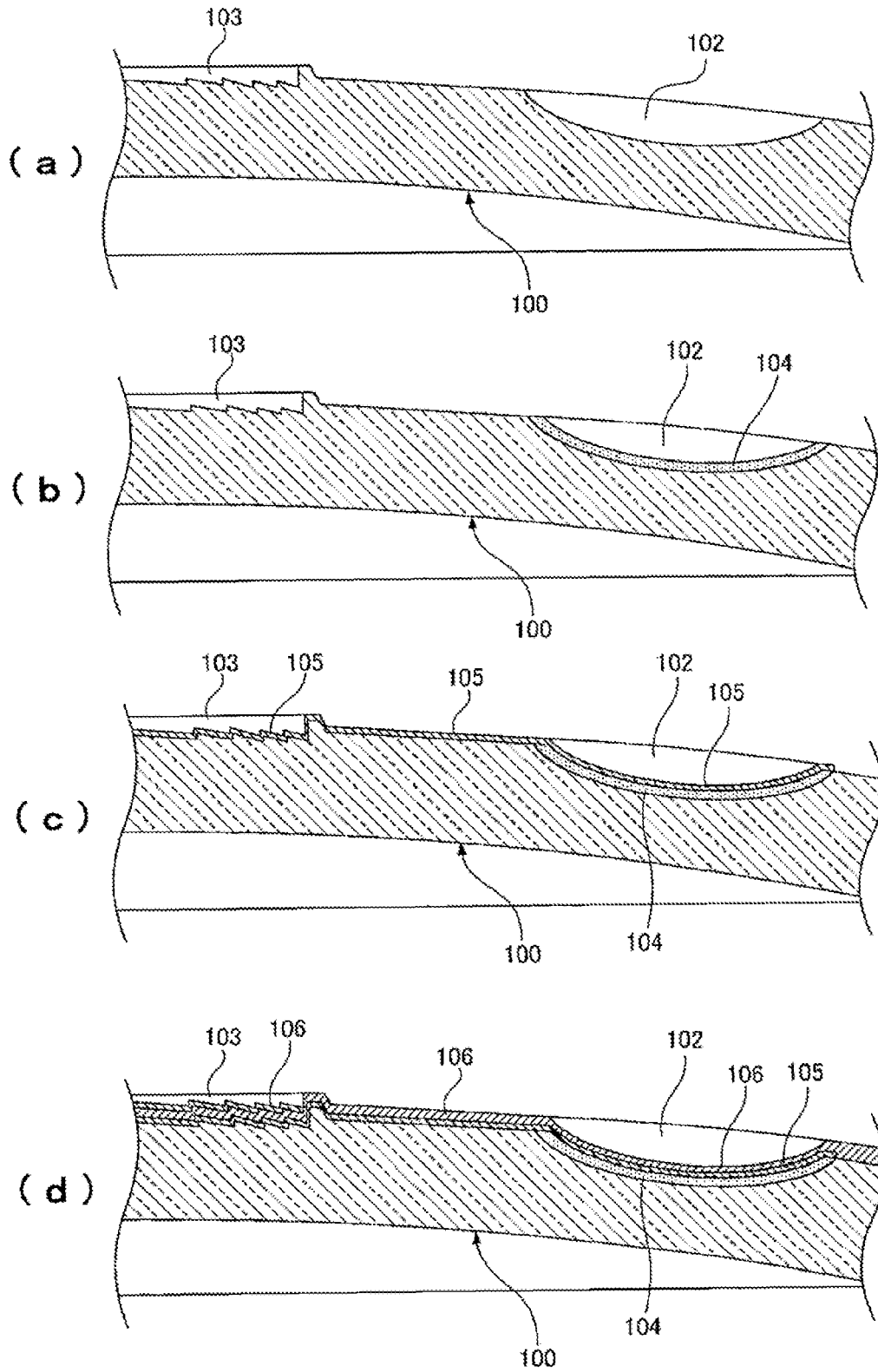

FIG. 29

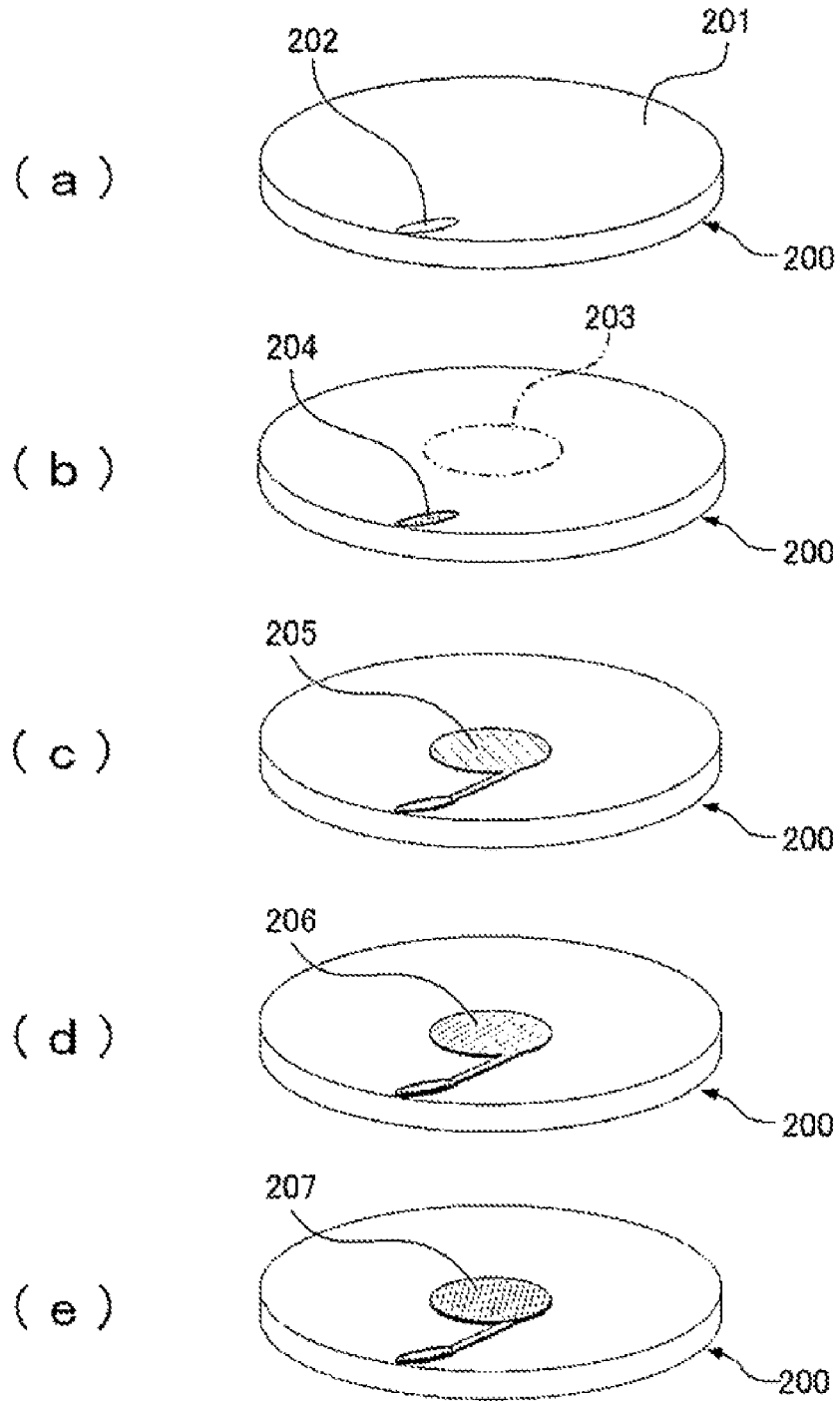

FIG. 30

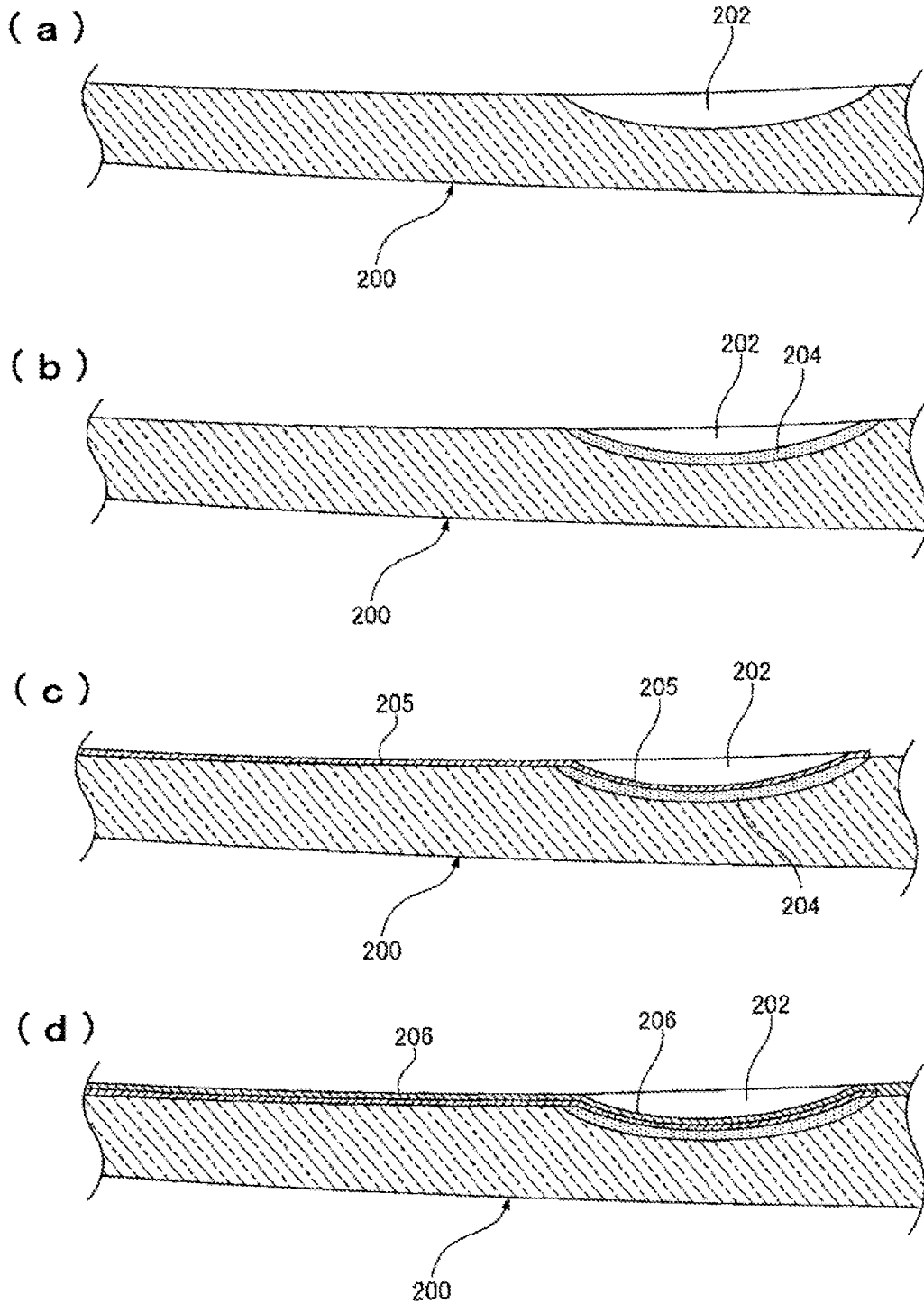

FIG. 31

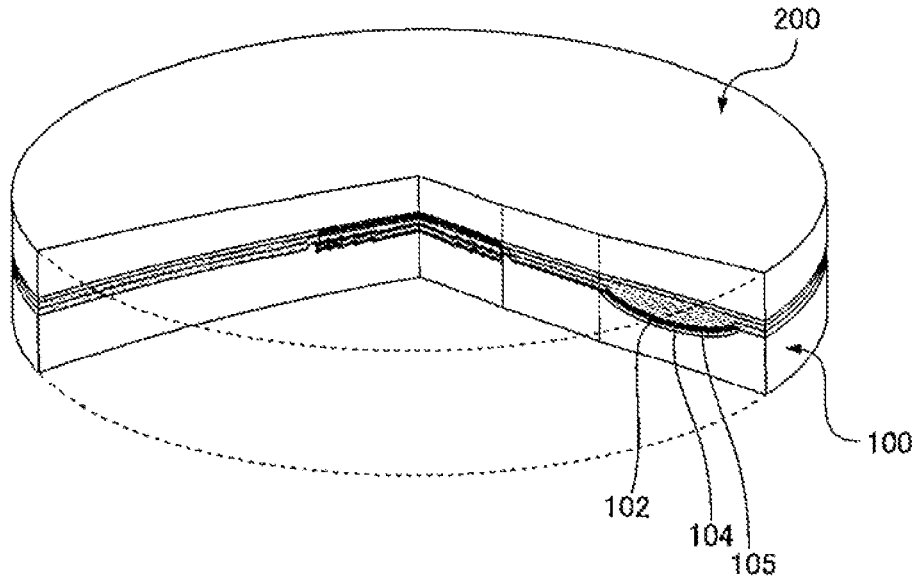

FIG. 32

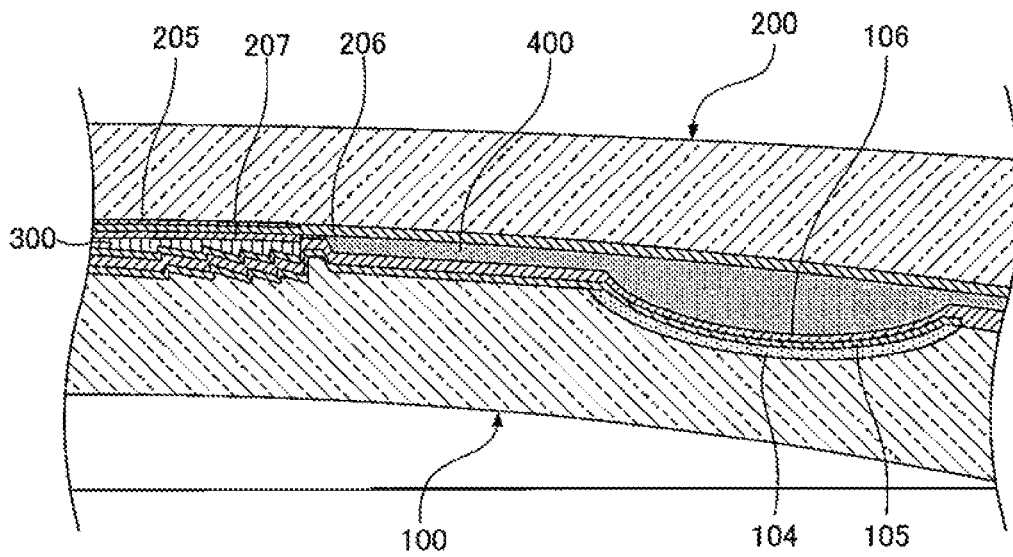

FIG. 33

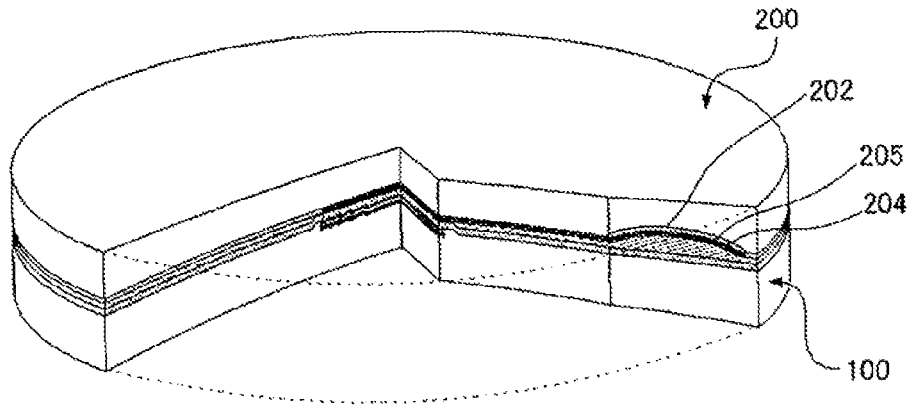

FIG. 34

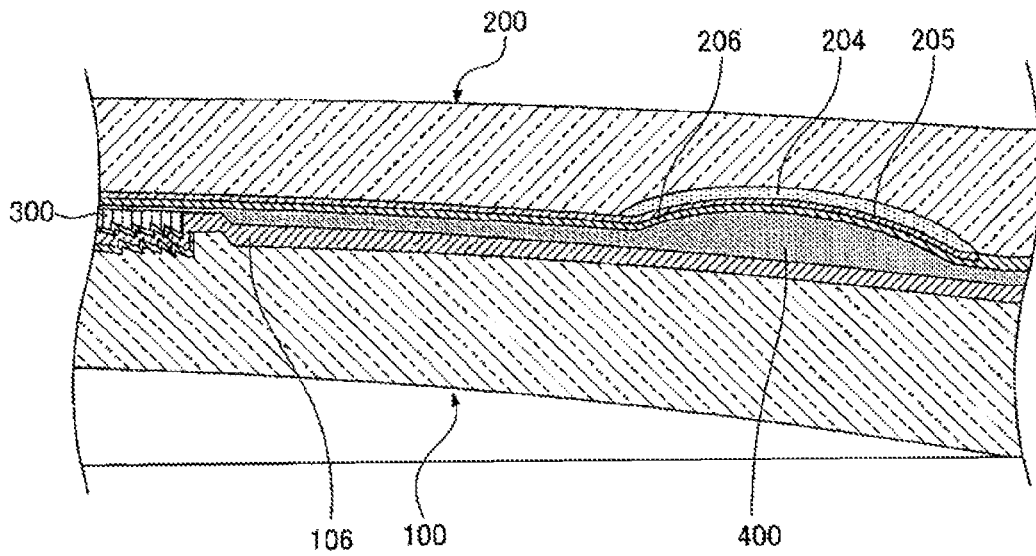

FIG. 35

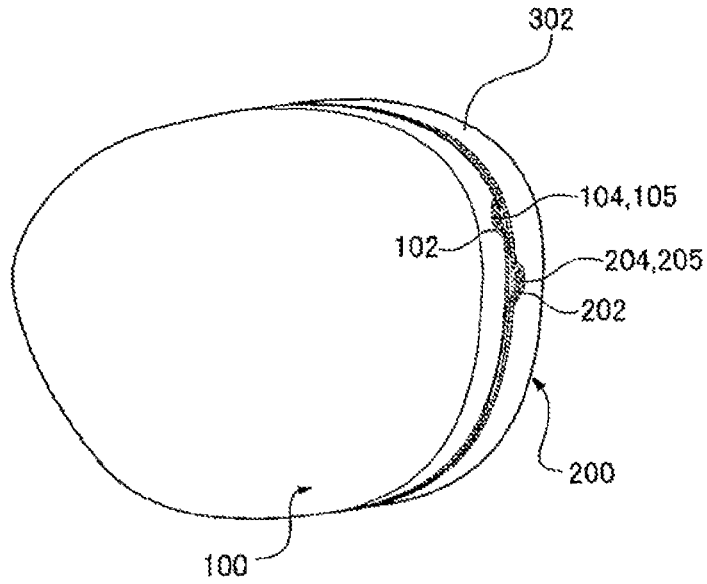

FIG. 36

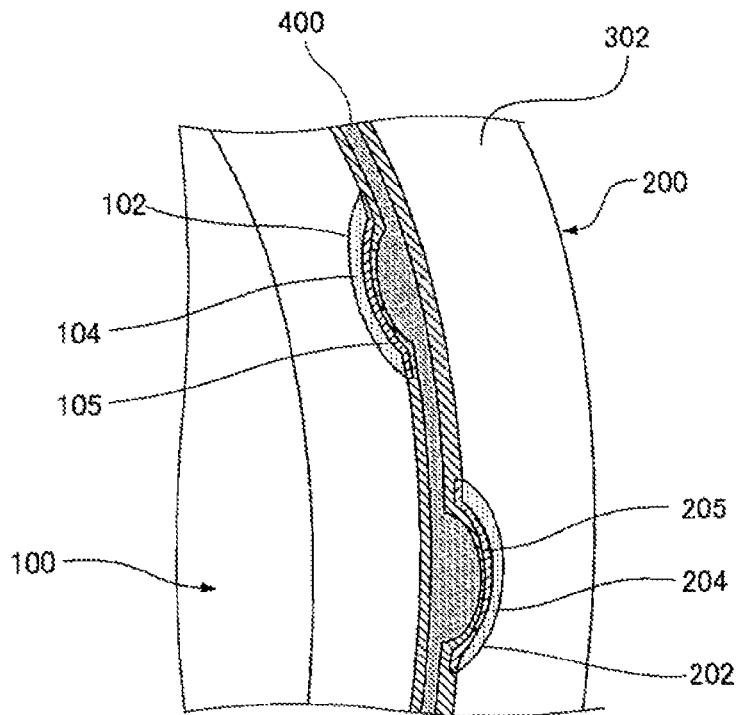

FIG. 37

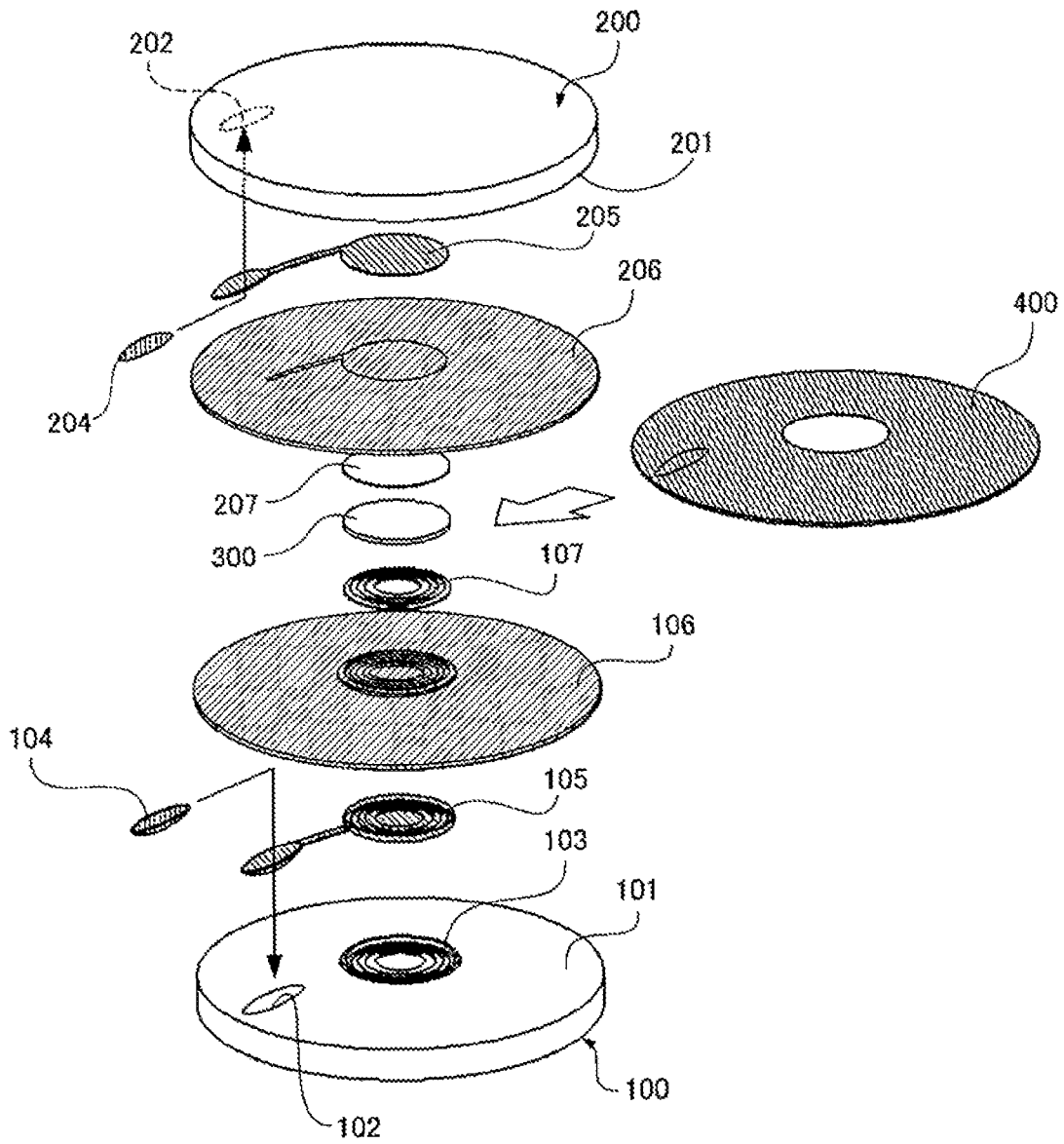

FIG. 38

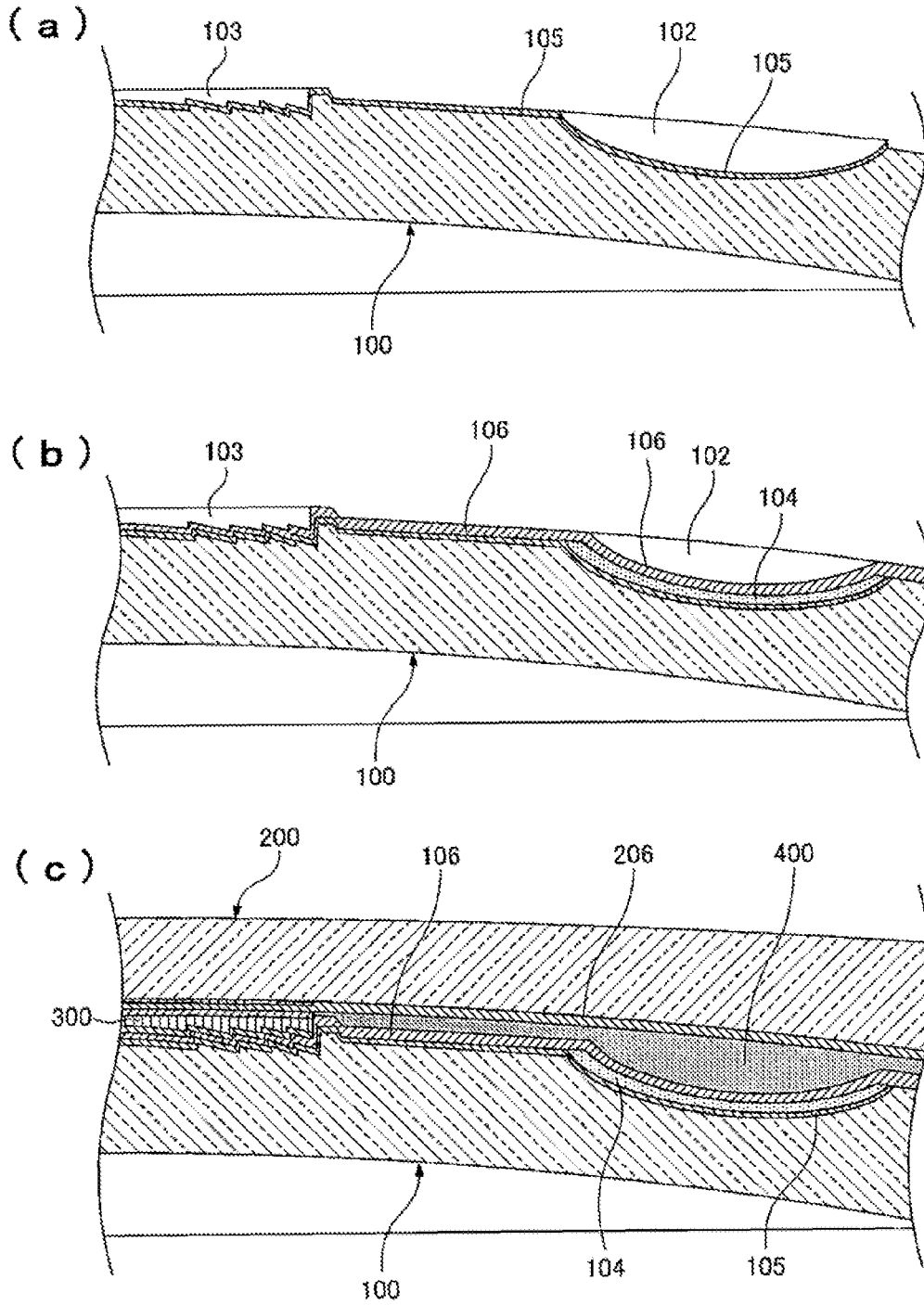

FIG. 39

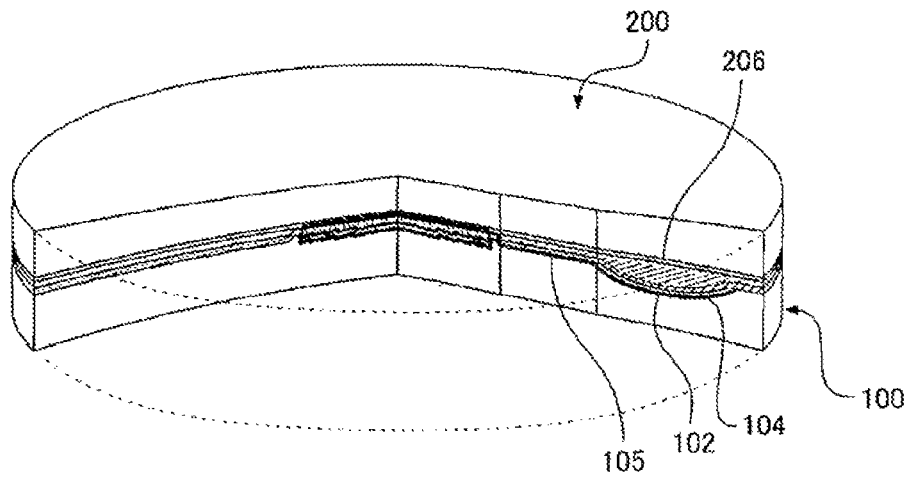

FIG. 40

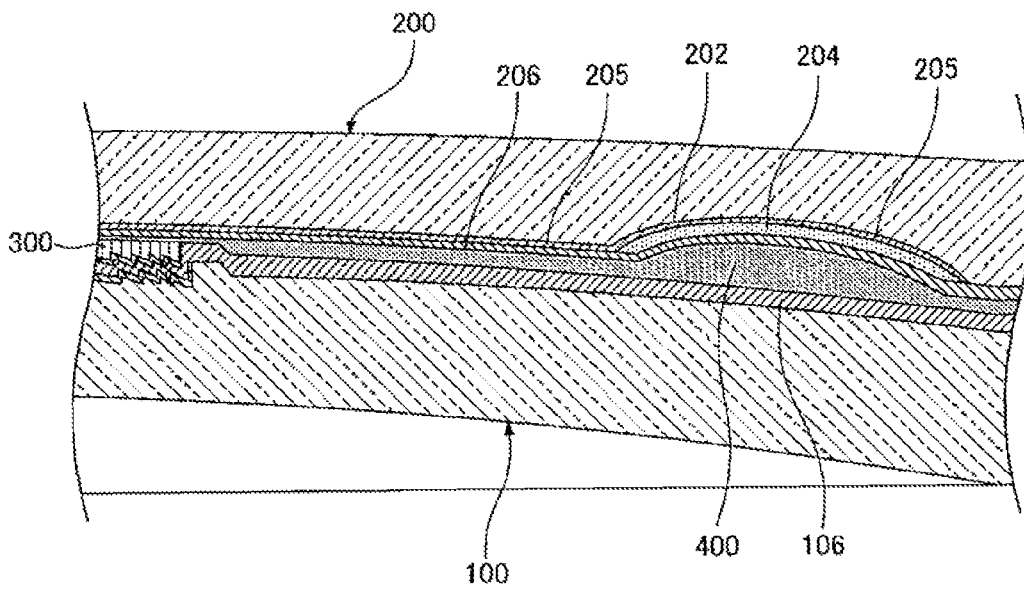

FIG. 41

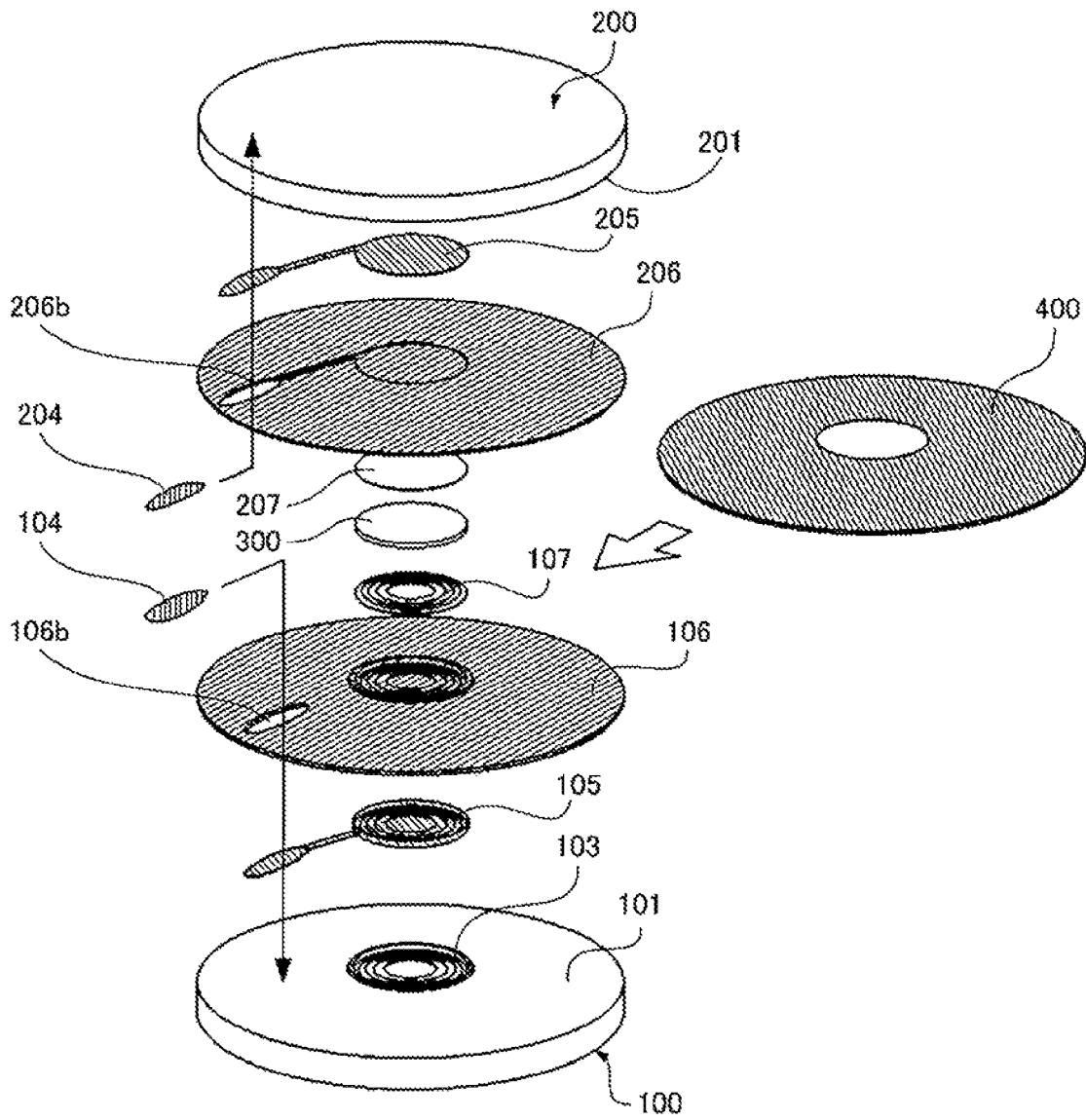

FIG. 42

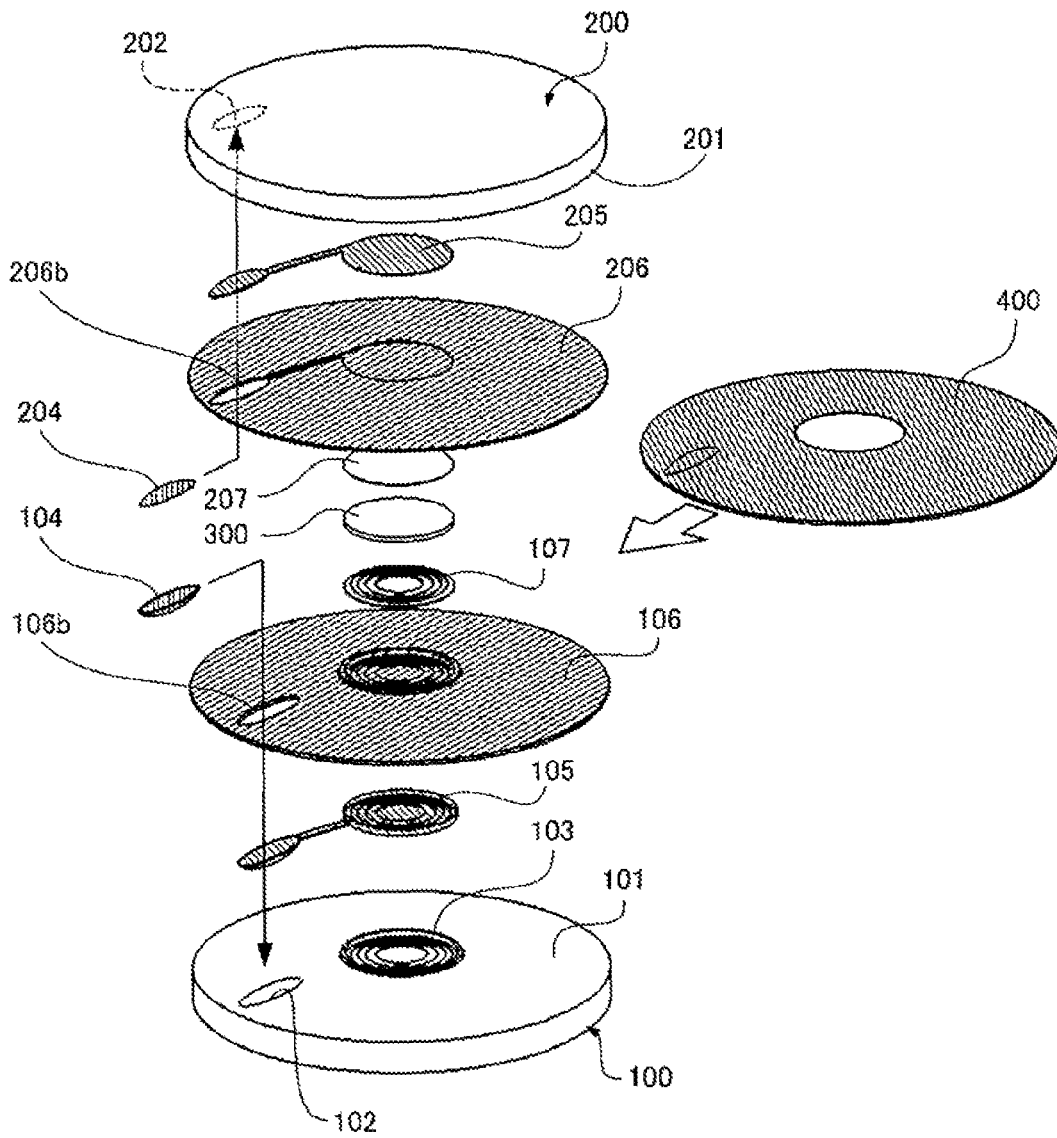

FIG. 43

PRIOR ART

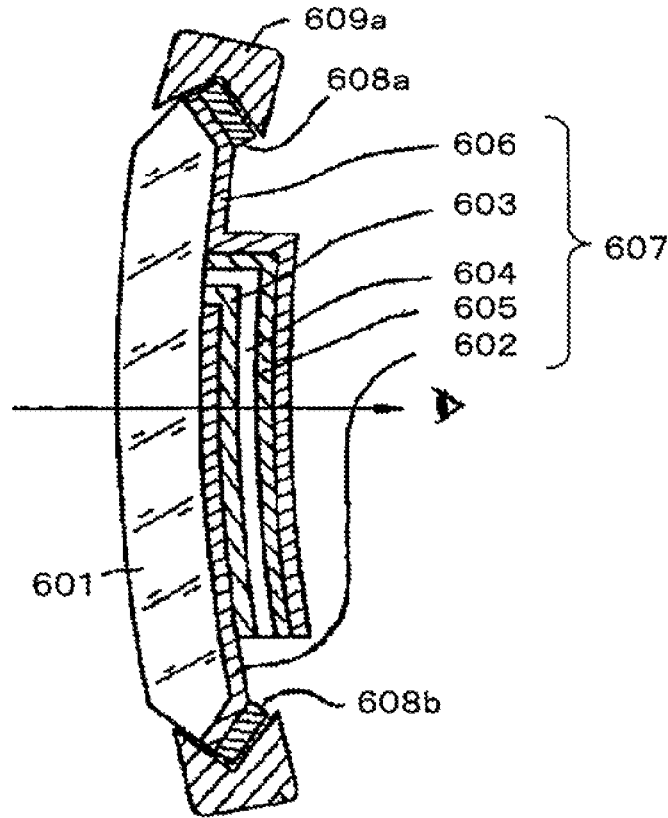
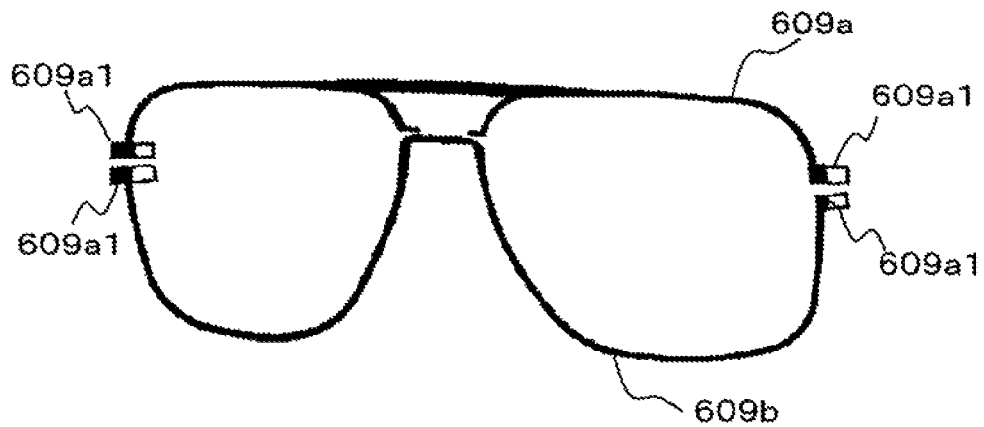

FIG. 44

PRIOR ART



1

**METHOD FOR MANUFACTURING LENS
FOR ELECTRONIC SPECTACLES, LENS
FOR ELECTRONIC SPECTACLES, AND
ELECTRONIC SPECTACLES**

Matter enclosed in heavy brackets [] appears in the original patent but forms no part of this reissue specification; matter printed in italics indicates the additions made by reissue; a claim printed with strikethrough indicates that the claim was canceled, disclaimed, or held invalid by a prior post-patent action or proceeding.

TECHNICAL FIELD

The present invention relates to electric wiring for an electric element of a lens part in electronic spectacles and proposes a structure capable of particularly improving the reliability of electric connection.

BACKGROUND ART

Electronic spectacles have been proposed in which electric elements such as an electrochromic (EC) element and a liquid crystal element are formed on or in a lens and the function of the lens is changed by supplying electric energy to the electric elements.

For example, electronic spectacles using EC elements are available.

In this example, an electrode wiring method for driving an EC element is shown in FIG. 43 that is a sectional view of a lens. As shown in FIG. 43, an EC element 607 formed on a substrate lens 601 is made up of a lower ITO transparent electrode 602, an Ir₂O₃/SnO₂ layer 603, a Ta₂O₅ layer 604, a WO₃ layer 605, and an upper ITO transparent electrode layer 606. Further, plated layers 608a and 608b of two-layer structures are formed on the outer periphery of the lens (the inclined surfaces of V-blocks) as electrodes for extraction from the electrode layers. The plated layers 608a and 608b are in electrical contact with the upper ITO transparent electrode layer 606 and the lower ITO transparent electrode layer 602, respectively. As shown in FIG. 44, the frame of the spectacles is made up of metallic upper and lower rims 609a and 609b sharing a current path. The upper and lower rims 609a and 609b are joined via an insulator such as a thin plastic sheet.

A method for joining the lens and the rims and connecting a control unit and the EC element 607 is disclosed in which the electrodes 608a and 608b formed on the outer periphery of the lens and the upper and lower rims 609a and 609b are brought into contact with each other and terminals from the control unit are fastened between rim locks 609a1 on the ends of the upper and lower rims 609a and 609b (e.g., see patent document 1). Patent document 1: Japanese Utility Model Laid-Open No. 2-138720

DISCLOSURE OF THE INVENTION

Problem to be Solved by the Invention

In the configuration of the prior art, however, the lower ITO transparent electrode 602 and the upper ITO transparent electrode layer 606, which are electrodes provided on the outer periphery of the lens, are electrically connected only through contact with the upper rim 609a and the lower rim 609b that act as rims. Thus the electrical connection may

2

become faulty when, for example, a screw (not shown) for fastening the rim locks 609a1 becomes loose.

In order to prevent the faulty electrical connection, it is necessary to increase the thickness of the ITO transparent electrode layer but a dry process such as [vacuum] vapor deposition cannot increase the thickness of the ITO transparent electrode layer. For this reason, the ITO transparent electrode layer is formed by using a wet process. In the wet process, however, ITO particles dispersed into an ink solvent increase the electrical resistance of the ITO transparent electrode layer, thereby degrading the operating characteristics of the element in the lens.

The present invention has been devised to solve the problem of the prior art. An object of the present invention is to provide electronic spectacles that can increase the reliability of electrical connection to an electronic circuit outside a lens without degrading the operating characteristics of an element in the lens of the electronic spectacles. Another object of the present invention is to provide a method for efficiently manufacturing the lens for electronic spectacles.

Means for Solving the Problem

A method for manufacturing a lens for electronic spectacles according to the present invention, in the fabrication of the lens containing an electric element between a lower substrate and an upper substrate, the method including: fabricating the lower substrate such that a first recess for lens electrode pads is formed on a surface of the lower substrate, the surface being opposed to the upper substrate, the first recess is coated with conductive ink to form a transparent first auxiliary electrode layer, and a transparent lower electrode pattern is formed on the electric element forming part of the lower substrate and the first auxiliary electrode layer by a [vacuum] vapor deposition method so as to connect the electric element forming part and the first auxiliary electrode layer; fabricating the upper substrate such that a second recess for the lens electrode pads is formed on a surface of the upper substrate, the surface being opposed to the lower substrate, the second recess is coated with conductive ink to form a transparent second auxiliary electrode layer, and a transparent upper electrode pattern is formed by the [vacuum] vapor deposition method on a part corresponding to the electric element forming part on the upper substrate and the second auxiliary electrode layer so as to connect the part corresponding to the electric element forming part and the second auxiliary electrode layer; and joining the upper and lower substrates with the electric element interposed between the electric element forming part of the lower substrate and the upper substrate.

A method for manufacturing a lens for electronic spectacles according to the present invention, in the fabrication of the lens containing an electric element between a lower substrate and an upper substrate, the method including: fabricating the lower substrate such that a first recess for lens electrode pads is formed on a surface of the lower substrate, the surface being opposed to the upper substrate, a lower electrode pattern is formed on the electric element forming part of the lower substrate and the first recess so as to connect the electric element forming part and the first recess, and the lower electrode pattern of the first recess is coated with conductive ink to form a transparent first auxiliary electrode layer; fabricating the upper substrate such that a transparent upper electrode pattern is formed by a [vacuum] vapor deposition method on a part corresponding to the electric element forming part on the upper substrate and a

3

second recess for the lens electrode pads so as to connect the part corresponding to the electric element forming part and the second recess, and the upper electrode pattern of the second recess is coated with conductive ink to form a transparent second auxiliary electrode layer; and joining the upper and lower substrates with the electric element interposed between the electric element forming part of the lower substrate and the upper substrate.

The method for manufacturing the lens for electronic spectacles further includes, after joining the upper and lower substrates, cutting the upper and lower substrates at positions on the first and second recesses to expose the cut surfaces of the first and second recesses on a lens end.

The method for manufacturing the lens for electronic spectacles further includes: after joining the upper and lower substrates, cutting the upper and lower substrates at positions on the first and second recesses to expose the cut surfaces of the first and second recesses on a lens end; and forming conductive paste on the exposed first and second recesses to form the lens electrode pad serving as an extraction electrode for the first auxiliary electrode layer and the lower electrode pattern and the lens electrode pad serving as an extraction electrode for the second auxiliary electrode layer and the upper electrode pattern.

A lens for electronic spectacles according to the present invention is a lens containing an electric element between two substrates, wherein a lens electrode pad on one end of an electrode for applying a voltage to the electric element is exposed on a lens end, and the lens electrode pad has the electrode formed in a recess on a bonded surface of one of the two substrates, the electrode being formed by stacking an auxiliary electrode layer formed of conductive ink and a lower electrode pattern formed by a [vacuum] *vapor* deposition method.

The recess is exposed on the lens end as a curved surface.

A method for manufacturing a lens for electronic spectacles according to the present invention, in the fabrication of the lens containing an electric element between a lower substrate and an upper substrate, the method including: fabricating the lower substrate such that a surface of the lower substrate is coated with conductive ink to form a transparent first auxiliary electrode layer for lens electrode pads, the surface being opposed to the upper substrate, and a transparent lower electrode pattern is formed by a [vacuum] *vapor* deposition method on the electric element forming part of the lower substrate and the first auxiliary electrode layer so as to connect the electric element forming part and the first auxiliary electrode layer; fabricating the upper substrate such that a surface of the upper substrate is coated with the conductive ink to form a transparent second auxiliary electrode layer for the lens electrode pads, the surface being opposed to the lower substrate, and a transparent upper electrode pattern is formed by the [vacuum] *vapor* deposition method on a part corresponding to the electric element forming part on the upper substrate and the second auxiliary electrode layer so as to connect the part corresponding to the electric element forming part and the second auxiliary electrode layer; and joining the upper and lower substrates with the electric element interposed between the electric element forming part of the lower substrate and the upper substrate.

A method for manufacturing a lens for electronic spectacles according to the present invention, in the fabrication of the lens containing an electric element between a lower substrate and an upper substrate, the method including: fabricating the lower substrate such that a transparent lower electrode pattern for applying a signal to the electric element

4

forming part of the lower substrate is formed by a [vacuum] *vapor* deposition method, and one end of the lower electrode pattern is coated with conductive ink to form a transparent first auxiliary electrode layer; fabricating the upper substrate such that a transparent upper electrode pattern is formed by the [vacuum] *vapor* deposition method, the upper electrode pattern applying a signal to a part corresponding to the electric element forming part on the upper substrate, and one end of the upper electrode pattern is coated with conductive ink to form a transparent second auxiliary electrode layer; and joining the upper and lower substrates with the electric element interposed between the electric element forming part of the lower substrate and the upper substrate.

The method for manufacturing the lens for electronic spectacles further includes, after joining the upper and lower substrates, cutting the upper and lower substrates at positions on the overlap portion of the first auxiliary electrode layer and the lower electrode pattern and the overlap portion of the second auxiliary electrode layer and the upper electrode pattern to expose the cut surfaces of the substrates.

The method for manufacturing the lens for electronic spectacles further includes: after joining the upper and lower substrates, cutting the upper and lower substrates at positions on the overlap portion of the first auxiliary electrode layer and the lower electrode pattern and the overlap portion of the second auxiliary electrode layer and the upper electrode pattern to expose the cut surfaces of the substrates; and forming conductive paste on the overlap portion of the first auxiliary electrode layer and the lower electrode pattern and the overlap portion of the second auxiliary electrode layer and the upper electrode pattern to form the lens electrode pad serving as an extraction electrode for the first auxiliary electrode layer and the lower electrode pattern and the lens electrode pad serving as an extraction electrode for the second auxiliary electrode layer and the upper electrode pattern.

A lens for electronic spectacles according to the present invention is a lens containing an electric element between two substrates, wherein an electrode for applying a voltage to the electric element has one end exposed on a lens end, and the one end of the electrode is formed by stacking an auxiliary electrode layer formed of conductive ink and a lower electrode pattern formed by a [vacuum] *vapor* deposition method.

A method for manufacturing a lens for electronic spectacles according to the present invention, in the fabrication of the lens containing an electric element between a lower substrate and an upper substrate, the method including: fabricating the lower substrate such that a transparent lower electrode pattern for applying a signal to the electric element forming part of the lower substrate is formed by a [vacuum] *vapor* deposition method, a lower insulating layer pattern is formed on the electric element forming part and the lower electrode pattern of the lower substrate except for a part to be coated with a first auxiliary electrode layer, and the hole of the lower insulating layer pattern is coated with conductive ink to form the transparent first auxiliary electrode layer; fabricating the upper substrate such that a transparent upper electrode pattern is formed by the [vacuum] *vapor* deposition method, the upper electrode pattern applying a signal to a part corresponding to the electric element forming part on the upper substrate, an upper insulating layer pattern is formed on the part corresponding to the electric element forming part on the upper substrate and on the upper electrode pattern except for a part to be coated with a second auxiliary electrode layer, and the hole of the upper insulating layer pattern is coated with conductive ink to form the

transparent second auxiliary electrode layer; and joining the upper and lower substrates with the electric element interposed between the electric element forming part of the lower substrate and the upper substrate.

A method for manufacturing a lens for electronic spectacles according to the present invention, in the fabrication of the lens containing an electric element between a lower substrate and an upper substrate, the method including: fabricating the lower substrate such that a first recess for lens electrode pads is formed on a surface of the lower substrate, the surface being opposed to the upper substrate, a lower electrode pattern is formed on the electric element forming part of the lower substrate and the first recess so as to connect the electric element forming part and the first recess, a lower insulating layer pattern is formed on the electric element forming part and the lower electrode pattern of the lower substrate except for a part to be coated with a first auxiliary electrode layer, and the hole of the lower insulating layer pattern is coated with conductive ink to form the transparent first auxiliary electrode layer; fabricating the upper substrate such that a transparent upper electrode pattern is formed by a [vacuum] *vapor* deposition method on a part corresponding to the electric element forming part on the upper substrate and a second recess for the lens electrode pads so as to connect the part corresponding to the electric element forming part and the second recess, an upper insulating layer pattern is formed on the upper electrode pattern and the part corresponding to the electric element forming part on the upper substrate, except for a part to be coated with a second auxiliary electrode layer, and the hole of the upper insulating layer pattern is coated with conductive ink to form the transparent second auxiliary electrode layer; and joining the upper and lower substrates with the electric element interposed between the electric element forming part of the lower substrate and the upper substrate.

Further, electronic spectacles of the present invention are electronic spectacles in which a lens containing an electric element is set in a spectacle frame, the lens having lens electrode pads exposed on the lens end, the lens electrode pads being disposed on one end of an electrode for applying a voltage to the electric element, the spectacle frame including an electric connector having one end connected to a control unit for controlling the electric element, the electric connector having wiring electrode pads disposed on the other end of the electric connector so as to correspond to the positions of the lens electrode pads of the lens, the electronic spectacles having anisotropic conductive rubber interposed between the wiring electrode pad of the electric connector and the lens electrode pad of the lens.

The electronic spectacles further include a rim-side spot facing in the rim of the spectacle frame, the electric connector being placed in the rim-side spot facing; and a lens-side spot facing on the lens end of the lens, the anisotropic conductive rubber being placed in the lens-side spot facing.

Further, the electric connector passes through the rim locks of the spectacle frame and is provided in the rim, and the wiring electrode pads are set inside the rim of the spectacle frame.

Advantage of the Invention

With this configuration, a lens for electronic spectacles has lens electrode pads exposed on a lens end and an electrode formed by stacking an auxiliary electrode layer formed of ITO ink and a lower electrode pattern obtained by ITO sputtering. Thus the electrode of an electrode pattern

can have a relatively small volume resistivity and a high light transmittance can be achieved without making the electrode pattern undesirably noticeable.

Further, a spectacle frame has an electric connector on which wiring electric pads are disposed at positions corresponding to the lens electrode pads of the lens, and anisotropic conductive rubber is interposed between the wiring electrode pads and the lens electrode pads. Thus it is possible to prevent disconnection caused by the loosening of a lens fastening part or a displacement of electric wiring and prevent electrical problems such as a short circuit caused by an electric leak.

BRIEF DESCRIPTION OF THE DRAWINGS

FIG. 1 is an enlarged view of the principle part of electronic spectacles according to a first embodiment of the present invention;

FIG. 2 is an enlarged view of the principle part of the electronic spectacles according to the first embodiment;

FIG. 3 is an enlarged view showing the principle part of electronic spectacles in which spot facings are formed according to a second embodiment of the present invention;

FIG. 4 is an enlarged view showing the principle part of the electronic spectacles in which spot facings are formed according to the second embodiment;

FIG. 5 shows a top view of the electronic spectacles and an enlarged view from a user;

FIG. 6 is an exploded image of a completed lens 1 according to a third embodiment of the present invention;

FIG. 7 is a perspective view showing a process of fabricating a lower substrate according to the third embodiment;

FIG. 8 is a sectional view showing the process of fabricating the lower substrate according to the third embodiment;

FIG. 9 is a perspective view showing a process of fabricating an upper substrate according to the third embodiment;

FIG. 10 is a sectional view showing the process of fabricating the upper substrate according to the third embodiment;

FIG. 11 is an enlarged perspective view in which a lens of the third embodiment is cut at a position on a first auxiliary electrode layer 104;

FIG. 12 is a sectional view in which the lens of the third embodiment is cut at the position on the first auxiliary electrode layer 104;

FIG. 13 is an enlarged perspective view in which the lens of the third embodiment is cut at a position on a second auxiliary electrode layer 204;

FIG. 14 is a sectional view in which the lens of the third embodiment is cut at the position on the second auxiliary electrode layer 204;

FIG. 15 is a plan view showing the cutting position of the lens according to the third embodiment;

FIG. 16 is an enlarged perspective view showing a lens end face of the cut lens according to the third embodiment;

FIG. 17 is an enlarged view showing the principle part of the third embodiment;

FIG. 18 shows a schematic view of a spectacle frame and an enlarged perspective view and a structural diagram of a lug of the spectacle frame according to the third embodiment;

FIG. 19 is a structural diagram showing that the lens is set in the spectacle frame according to the third embodiment;

FIG. 20 is an enlarged perspective view of another example in which silver paste is applied to a lens end face of the lens according to the third embodiment;

FIG. 21 is a structural diagram showing another example in which the lens is set in the spectacle frame according to the third embodiment;

FIG. 22 is an exploded image of a completed lens 1 according to a fourth embodiment of the present invention;

FIG. 23 is a sectional view showing a process of fabricating a lower substrate according to the fourth embodiment;

FIG. 24 is an enlarged perspective view in which a lens of the fourth embodiment is cut at a position on a first auxiliary electrode layer 104;

FIG. 25 is a sectional view in which the lens of the fourth embodiment is cut at a position on a second auxiliary electrode layer 204;

FIG. 26 is an exploded image of a completed lens 1 according to a fifth embodiment of the present invention;

FIG. 27 is a perspective view showing a process of fabricating a lower substrate according to the fifth embodiment;

FIG. 28 is a sectional view showing the process of fabricating the lower substrate according to the fifth embodiment;

FIG. 29 is a perspective view showing a process of fabricating an upper substrate according to the fifth embodiment;

FIG. 30 is a sectional view showing the process of fabricating the upper substrate according to the fifth embodiment;

FIG. 31 is an enlarged perspective view in which a lens of the fifth embodiment is cut at a position on a first recess 102;

FIG. 32 is a sectional view in which the lens of the fifth embodiment is cut at the position on the first recess 102;

FIG. 33 is an enlarged perspective view in which the lens of the fifth embodiment is cut at a position on a second recess 202;

FIG. 34 is a sectional view in which the lens of the fifth embodiment is cut at the position on the second recess 202;

FIG. 35 is a plan view showing the cutting position of the lens according to the fifth embodiment;

FIG. 36 is an enlarged perspective view showing a lens end face of the cut lens according to the fifth embodiment;

FIG. 37 is an exploded image of a completed lens 1 according to a sixth embodiment of the present invention;

FIG. 38 is a sectional view showing a process of fabricating a lower substrate according to the sixth embodiment;

FIG. 39 is an enlarged perspective view in which a lens of the sixth embodiment is cut at a position on a first recess 102;

FIG. 40 is a sectional view in which the lens of the sixth embodiment is cut at a position on a second recess 202;

FIG. 41 is an exploded image of a completed lens 1 according to a seventh embodiment of the present invention;

FIG. 42 is an exploded image of a completed lens 1 according to an eighth embodiment of the present invention;

FIG. 43 shows electronic spectacles of the prior art; and

FIG. 44 shows the electronic spectacles of the prior art.

BEST MODE FOR CARRYING OUT THE INVENTION

The following will specifically describe embodiments of electronic spectacles of the present invention in accordance with the accompanying drawings.

First Embodiment

FIGS. 5(a) and 5(b) show electronic spectacles.

FIG. 1 is a sectional view taken along line A-A of FIG. 5(a) and a sectional view of the joints of lens electrode pads and wiring electrode pads according to a first embodiment of the present invention.

FIG. 2 is a sectional view taken along line B-B of FIG. 5(b) and an image of the joint of the lens electrode pad and the wiring electrode pad.

The electronic spectacles of the present invention include a spectacle frame 11; a lens 1 that has an electric element (not shown) such as a liquid crystal and an electrochromic element and is set in a rim 8 of the spectacle frame 11; a control unit 5 that is provided beside the spectacle frame 11 and generates an electric signal for driving the electric element of the lens 1; an electric connector 4 that is provided beside the spectacle frame 11 and transmits a signal from the control unit 5; anisotropic conductive rubber 7 sandwiched between the lens 1 and the rim 8; and a screw 10 for fastening upper and lower rim locks 9 of the rim 8.

The lens 1 is fit into a groove 8a formed inside the rim 8. The lens 1 has electrode patterns 2a and 2b for transmitting the electric signal to the electric element and lens electrode pads 3a and 3b that are formed on a V-block 1a to increase the contact areas of the electrode patterns 2a and 2b on the ends of the electrode patterns 2a and 2b.

On one end of the electric connector 4 beside the spectacle frame 11, electrode pads 6a and 6b are formed so as to be electrically connected to the lens electrode pads 3a and 3b via the anisotropic conductive rubber 7.

The electrode patterns 2a and 2b are formed of extremely thin transparent electrodes such as ITO electrodes and are exposed to the outside on the V-block 1a provided on the outer sidewall of the lens 1. The electrode patterns 2a and 2b are only about 10 nm to 40 nm in thickness and are exposed to the outside as extremely thin lines of about 10 nm to 40 nm. Thus the electrode patterns 2a and 2b may be in poor electric contact with the anisotropic conductive rubber 7. For this reason, in the first embodiment, silver paste and nanoparticles are used for the electrode patterns 2a and 2b exposed to the outside of the lens 1 and the lens electrode pads 3a and 3b are formed on a plane of the V-block 1a to expand an electrode part.

In this case, the electrode patterns 2a and 2b are spaced only several μm apart in the thickness direction of the lens, the spacing being substantially equal to the thickness of the electric element. In order to form the lens electrode pads 3a and 3b respectively on the electrode patterns 2a and 2b, it is necessary to prevent the electrode patterns 2a and 2b on the end of the lens from overlapping each other in the thickness direction of the lens.

The electric signal generated from the control unit 5 made up of a power supply and an IC (integrated circuit) is transmitted to the wiring electrode pads 6a and 6b, which are shaped like the lens electrode pads 3a and 3b, through the electric connector 4 such as a flexible substrate, and then the electric signal is transmitted to the lens electrode pads 3a and 3b through the anisotropic conductive rubber 7.

The anisotropic conductive rubber 7 provided between the lens electrode pads 3a and 3b and the wiring electrode pads 6a and 6b is typical anisotropic conductive rubber that has a side wall surface coated with a rubber material such as silicone. The shape of the anisotropic conductive rubber 7 is set such that the anisotropic conductive rubber 7 serving as an elastic body is sufficiently compressed (deformed) in contact with the exposed surface of a conducting part when the rim locks 9 are fastened by the screw 10 to attach the lens.

Thus even when the screw **10** fastening the rim locks **9** becomes somewhat loose, the electronic spectacles configured thus can be used without electrical disconnection because the anisotropic conductive rubber **7** is elastically deformed.

Further, the lens electrode pads **3a** and **3b** and the wiring electrode pads **6a** and **6b** can be sealed by the compressive deformation of the anisotropic conductive rubber **7**, so that the electronic spectacles can be used even in the rain without causing short circuits.

Second Embodiment

As shown in FIG. **2**, an inverted-V protrusion called the V-block **1a** is formed on the outer periphery of the lens **1** and the V-groove **8a** is formed on the inner periphery of the rim **8** provided beside the spectacle frame **11**.

In the most typical method, the lens **1** is attached to the spectacle frame by fixing the V-block **1a** and the groove **8a** in engagement with each other. In this configuration, however, the screw **10** fastening the rim locks **9** applies a force diagonally to the anisotropic conductive rubber **7** and the electric connector **4**, so that the anisotropic conductive rubber **7** and the electric connector **4** may be displaced from the predetermined positions and result in poor assembly (fitting of the lens) and electrical connection.

A second embodiment configured as shown in FIGS. **3** and **4** has improved in that a force is not diagonally applied to an anisotropic conductive rubber **7** and an electric connector **4** during assembly.

FIG. **3** is an image of a sectional view showing the joints of the lens electrode pads and wiring electrode pads of electronic spectacles and FIG. **3** is equivalent to a sectional view taken along line A-A of FIG. **5(a)** in which the electronic spectacles are viewed from the top. FIG. **4** is an image showing the joints of the lens electrode pads and the wiring electrode pads of the electronic spectacles and FIG. **4** is equivalent to a sectional view taken along line B-B of FIG. **5(b)** in which the electronic spectacles are viewed from the front.

As shown in FIGS. **3** and **4**, a lens-side spot facing **1b** for the anisotropic conductive rubber **7** is formed around lens electrode pads **3a** and **3b** on a lens **1**. Further, on a spectacle frame **11**, a rim-side spot facing **8b** is formed on a part where an electric connector **4** is set inside a rim **8**.

The anisotropic conductive rubber **7** and the electric connector **4** are set thus in the spot facings **1b** and **8b**, respectively. Thus even a screw **10** fastening rim locks **9** hardly displaces the anisotropic conductive rubber **7** and the electric connector **4**, so that it is possible to stably assemble the electronic spectacles and prevent disconnection caused by a displacement of electric wiring.

To be specific, the lens-side spot facing **1b** and the rim-side spot facing **8b** are formed such that a load is applied perpendicularly to the bottoms of the lens-side spot facing **1b** and the rim-side spot facing **8b** when the rim locks **9** are fastened by the screw **10**. This configuration makes it possible to stably assemble the electronic spectacles and prevent disconnection caused by a displacement of the electric wiring.

In the foregoing embodiments, one end of the electric connector **4** may be connected to the control unit **5** and the wiring electrode pads **6a** and **6b** on the other end of the electric connector **4** may be set in the groove **8a** of the rim **8** so as to be opposed to the lens electrode pads **3a** and **3b**. For example, the electric connector **4** can be set around the rim locks **9** and the rim **8**.

In this example, as shown in FIGS. **1**, **2**, **3**, and **4**, the electric connector **4** is passed between the rim locks **9** and is placed in the groove **8a** or the spot facing **8b** inside the rim **8** to further stabilize the electric connection. Since the electric connector **4** is set between the rim locks, it is possible to prevent a displacement of the electric connector **4** during assembly and make the electric connector **4** undetachable.

To be specific, the electric connector **4** may be fixed between the rim locks **9** or grooves for the electric connector **4** may be formed on the rim locks **9**. Moreover, a positioning pin for the electric connector **4** may be provided in the rim locks **9** or the screw **10** may be used as a positioning pin. When grooves are formed, the groove patterns of the formed grooves may be used as positioning patterns, thereby preventing the electric connector **4** from being displaced or detached.

The electric connector **4** set between the rim locks **9** can achieve additional effect on appearance because the electric connector **4** is not exposed to the outside and does not interfere with the design of the spectacles.

In the present embodiment, the position of the control unit **5** is not limited as long as the control unit **5** is fixed inside a temple constituting the spectacles or at a lug on the spectacles. By setting the control unit **5** near the rim locks, the electric connector **4** can be shortened in length.

Third Embodiment

FIGS. **6** to **19** show a method for manufacturing a lens **1** for electronic spectacles.

FIG. **6** shows an exploded image of the completed lens **1** for better understanding of the manufacturing process. The lens **1** contains a liquid crystal **300** serving as an electric element between a lower substrate **100** and an upper substrate **200**. Reference numeral **400** denotes an adhesive layer for joining the lower substrate **100** and the upper substrate **200**.

FIGS. **7** and **8** show a process for fabricating the lower substrate **100**.

In FIG. **7(a)**, an electric element forming part **103** is formed on a surface **101** of the lower substrate **100** as shown in FIG. **8(a)**. The surface **101** is opposed to the upper substrate **200** and the liquid crystal **300** is placed later on the electric element forming part **103**.

In FIG. **7(b)**, the lower substrate **100** having a smooth surface is partially coated with conductive ink to form a first auxiliary electrode layer **104** as shown in FIG. **8(b)**. To be specific, ITO ink that is conductive ink is used. Regarding the physical property of the ITO ink, the ITO ink containing dispersed conductive particles has a large volume resistivity of about $2.4 \times 10^9 \Omega \cdot \text{cm}$ as compared with a conductive film formed by ITO sputtering with a volume resistivity of about 6 to $2 \times 10^{-4} \Omega \cdot \text{cm}$, whereas an ITO ink film formed with a thickness of $1 \mu\text{m}$ has a spectral transmittance substantially equal to the spectral transmittance of an ITO conductive film formed by sputtering with a thickness of 30 nm . Therefore, the conductive film of the ITO ink is more transparent than the ITO conductive film formed by sputtering, on the assumption that films are equal in thickness. The ITO ink can obtain a transmittance of about 80% even when the film is $1 \mu\text{m}$ in thickness. The ITO ink may be applied by an ink-jet method or a dispenser. Further, the ITO ink can be applied also by spin coating or dipping at a necessary point on the lower substrate **100** masked with tape and the like. The first auxiliary electrode layer **104** formed of the ITO ink is preferably at least $1 \mu\text{m}$ in thickness.

In FIG. 7(c), a lower electrode pattern **105** is formed on the electric element forming part **103** and the first auxiliary electrode layer **104** so as to connect the electric element forming part **103** and the first auxiliary electrode layer **104** as shown in FIG. 8(c). To be specific, ITO sputtering is performed using a mask pattern connecting the electric element forming part **103** and the first auxiliary electrode layer **104**. The lower electrode pattern **105** is about 10 nm to 40 nm in thickness.

In FIG. 7(d), a lower insulating layer pattern **106** is formed on the electric element forming part **103** and the lower electrode pattern **105** as shown in FIG. 8(d). To be specific, after ITO sputtering in FIG. 7(c), SiO₂ is continuously sputtered without removing the lower substrate **100** from a chamber (without exposing the lower substrate **100** to the atmosphere). Such sputtering can be performed by a sputtering apparatus having multiple targets in a single chamber and thus a special apparatus is not necessary.

In FIG. 7(e), an alignment layer **107** is applied to a part to be coated with the liquid crystal **300**, and rubbing is performed thereon.

FIGS. 9 and 10 show a process for fabricating the upper substrate **200**.

The upper substrate **200** having a smooth surface as shown in FIG. 9(a) is coated with conductive ink as shown in FIG. 10(b), so that a second auxiliary electrode layer **204** is formed as shown in FIG. 9(b). The conductive ink may be applied by an ink-jet method or a dispenser. Further, the conductive ink can be applied by spin coating or dipping at a necessary point on the upper substrate **200** masked with tape and the like. The second auxiliary electrode layer **204** is preferably at least 1 μm in thickness.

In FIG. 9(c), an upper electrode pattern **205** is formed on a part **203** and the second auxiliary electrode layer **204** so as to connect the part **203** and the second auxiliary electrode layer **204** as shown in FIG. 10(c). The part **203** corresponds to the electric element forming part **103** on the lower substrate **100**. To be specific, ITO sputtering is performed using a mask pattern connecting the part **203** and the second auxiliary electrode layer **204**. The upper electrode pattern **205** is about 10 nm to 40 nm in thickness.

In FIG. 9(d), an upper insulating layer pattern **206** is formed on the upper electrode pattern **205** as shown in FIG. 10(d). To be specific, after ITO sputtering in FIG. 9(c), SiO₂ is continuously sputtered without removing the upper substrate **200** from a chamber device (without exposing the upper substrate **200** to the atmosphere). Such sputtering can be performed by a sputtering apparatus having multiple targets in a single chamber and thus a special apparatus is not necessary.

In FIG. 9(e), an alignment layer **207** is applied onto the upper electrode pattern **205** so as to correspond to the part **203** and rubbing is performed thereon. The lower substrate **100** and the upper substrate **200** are bonded with an adhesive layer **400** in a state in which the liquid crystal **300** serving as the electric element is interposed between the electric element forming part **103** of the lower substrate **100** fabricated thus and the upper substrate **200**. To be specific, the liquid crystal **300** is applied by a dispenser or the ink jet method. After the liquid crystal **300** is applied, an adhesive (sealing agent) is applied around the liquid crystal **300** and then the lower substrate **100** and the upper substrate **200** are bonded with the adhesive layer **400**.

FIG. 11 is an enlarged perspective view in which the bonded lower substrate **100** and upper substrate **200** are cut at a position on the first auxiliary electrode layer **104**. FIG. 12 is an enlarged view of the principle part of FIG. 11. FIG.

13 is an enlarged perspective view in which the bonded lower substrate **100** and upper substrate **200** are cut at a position on the second auxiliary electrode layer **204**. FIG. 14 is an enlarged view of the principle part of FIG. 13.

As shown in FIG. 15, the lower substrate **100** and the upper substrate **200** that have been bonded thus are cut along a cutting line **301** according to the shape of the rim of the spectacle frame **11**. The cutting line **301** passes through the end of the first auxiliary electrode layer **104** and the end of the second auxiliary electrode layer **204**. Since the substrates are cut thus, as shown in FIG. 16, the end face of the overlap portion of the first auxiliary electrode layer **104** and the lower electrode pattern **105** and the end face of the overlap portion of the second auxiliary electrode layer **204** and the upper electrode pattern **205** are exposed on a lens end **302**. As shown in FIG. 17, the end faces of the first auxiliary electrode layer **104** and the lower electrode pattern **105** are exposed on the lower substrate **100** and the end faces of the second auxiliary electrode layer **204** and the upper electrode pattern **205** are exposed on the upper substrate **200**.

As shown in FIGS. 18 and 19, the electronic spectacles can be constructed using the lens of FIG. 16. The lenses **1** are set in the spectacle frame **11**.

As shown in FIG. 18(a), flexible wires **305a** and **305b** serving as an electric connector **4** are provided at a lug **304** of the spectacle frame **11**. The flexible wires **305a** and **305b** have one ends connected to the control unit **5** and wiring electrode pads **306a** and **306b** are formed on the other ends of the flexible wires **305a** and **305b**. As shown in FIG. 18(b), the wiring electrode pads **306a** and **306b** are set in a rim **307** of the spectacle frame **11**.

When the lens **1** is set in the rim **307**, anisotropic conductive rubber **308** is disposed as shown in FIG. 19 between the wiring electrode pads **306a** and **306b** and the first auxiliary electrode layer **104**, the lower electrode pattern **105**, the second auxiliary electrode layer **204**, and the upper electrode pattern **205** of the lens **1**. In this state, the lens **1** is supported by the rim **307** with a screw **10**, so that the wiring electrode pad **306a** is electrically connected to the lower electrode pattern **105** of the lens in a reliable manner via the anisotropic conductive rubber **308**. Further, the wiring electrode pad **306b** is electrically connected to the upper electrode pattern **205** of the lens in a reliable manner via the anisotropic conductive rubber **308**. This is because the first auxiliary electrode layer **104** formed on the lower electrode pattern **105** increases a contact area with the anisotropic conductive rubber **308** and improves electrical continuity. The second auxiliary electrode layer **204** has the same effect. With this configuration, a voltage for driving the liquid crystal **300** can be applied between the lower electrode pattern **105** and the upper electrode pattern **205** of the lens **1** from the control unit **5**.

In the case where the lower electrode pattern **105** is increased in thickness and the first auxiliary electrode layer **104** is not provided or in the case where the upper electrode pattern **205** is increased in thickness and the second auxiliary electrode layer **204** is not provided, as compared with the present embodiment, the resistance of the electrode can be reduced but light transmittance decreases without the first and second auxiliary electrode layers **104** and **204**. The light transmittance is an important factor of the electronic spectacles. Consequently, the lower electrode pattern **105** and the upper electrode pattern **205** can be easily visible in an undesirably noticeable manner. In contrast to this configuration, in the third embodiment, the lower electrode pattern **105** is reduced in thickness and the first auxiliary electrode layer **104** is stacked thereon to increase the overall thickness.

13

Further, the upper electrode pattern 205 is reduced in thickness and the second auxiliary electrode layer 204 is stacked thereon to increase the overall thickness. Thus the electrode can have a relatively low resistance and the lower electrode pattern 105 and the upper electrode pattern 205 are not noticeable. For this reason, the laminated structure of the first and second auxiliary electrode layers 104 and 204 is quite effective.

In the case where the lower substrate 100 and the upper substrate 200 are coated with the first and second auxiliary electrode layers 104 and 204 and then the lower electrode pattern 105 and the upper electrode pattern 205 are formed thereon, the lower insulating layer pattern 106 and the upper insulating layer pattern 206 can be formed, as previously mentioned, on the lower electrode pattern 105 and the upper electrode pattern 205 by continuous sputtering without removing the lower substrate 100 and the upper substrate 200 by opening the chamber to the atmosphere.

To be specific, in the case where the lower electrode pattern 105 and the upper electrode pattern 205 are formed on the lower substrate 100 and the upper substrate 200 and then the first and second auxiliary electrode layers 104 and 204 are applied thereon, it is necessary to form the lower insulating layer pattern 106 and the upper insulating layer pattern 206 after forming the lower electrode pattern 105 and the upper electrode pattern 205 by sputtering, opening the sputtering apparatus to the atmosphere to remove the lower substrate 100 and the upper substrate 200, and then changing the mask pattern. Thus vacuum drawing performed twice in the sputtering apparatus results in a complicated fabrication process.

In the third embodiment, the first and second auxiliary electrode layers 104 and 204 are first formed on the lower substrate 100 and the upper substrate 200. In this case, the lower electrode pattern 105 and the lower insulating layer pattern 106 can be formed on the lower substrate 100 without opening the sputtering apparatus to the atmosphere, and the upper electrode pattern 205 and the upper insulating layer pattern 206 can be formed on the upper substrate 200 without opening the sputtering apparatus to the atmosphere, thereby achieving a simple fabrication process.

As shown in FIGS. 20 and 21, it is more preferable to apply conductive paste on the first auxiliary electrode layer 104 and the second auxiliary electrode layer 204 because the conductive paste increases the contact area. To be specific, as shown in FIG. 20, silver pastes 303a and 303b are respectively applied as conductive pastes to the exposed end face of the overlap portion of the first auxiliary electrode layer 104 and the lower electrode pattern 105 and the end face of the overlap portion of the second auxiliary electrode layer 204 and the upper electrode pattern 205. Ideally, the silver paste 303a formed on the lens end 302 is electrically connected to the first auxiliary electrode layer 104 as well as the lower electrode pattern 105. In the present embodiment, the thin lower electrode pattern 105 is exposed on the lens end 302 and the first auxiliary electrode layer 104 having a larger thickness than the lower electrode pattern 105 is also exposed on the lens end 302. Thus even when the lower electrode pattern 105 is insufficiently exposed on the lens end 302, the silver paste 303a can be electrically connected to the lower electrode pattern 105 in a reliable manner via the thick first auxiliary electrode layer 104.

Similarly, it is ideal that the silver paste 303b formed on the lens end 302 is electrically connected to the second auxiliary electrode layer 204 as well as the upper electrode pattern 205. In the present embodiment, the thin upper electrode pattern 205 is exposed on the lens end 302 and the

14

second auxiliary electrode layer 204 having a larger thickness than the upper electrode pattern 205 is also exposed on the lens end 302. Thus even when the upper electrode pattern 205 is insufficiently exposed on the lens end 302, the silver paste 303b can be electrically connected to the upper electrode pattern 205 in a reliable manner via the thick second auxiliary electrode layer 204.

Fourth Embodiment

FIGS. 22 to 25 show a fourth embodiment of the present invention.

In the third embodiment, the lower substrate 100 is coated with the first auxiliary electrode layer 104 and then the lower electrode pattern 105 is formed thereon, and the upper substrate 200 is coated with the second auxiliary electrode layer 204 and then the upper electrode pattern 205 is formed thereon. The fourth embodiment is different only in that first and second auxiliary electrode layers 104 and 204 are applied later and other points are similar to those of the third embodiment.

FIG. 22 shows an exploded image of a completed lens 1 for better understanding of the manufacturing process.

In FIG. 23(a), a lower electrode pattern 105 is formed from an electric element forming part 103 of a lower substrate 100 to a part near the outer periphery of the lower substrate 100.

In FIG. 23(b), only one end of the lower electrode pattern 105 is coated with conductive ink to form the first auxiliary electrode layer 104. After that, a lower insulating layer pattern 106 is formed on the electric element forming part 103 and the first auxiliary electrode layer 104 from the lower electrode pattern 105. Further, as shown in FIG. 22, an alignment layer 107 is formed on the lower insulating layer pattern 106 so as to correspond to the position of the electric element forming part 103.

Also in this case, an upper substrate 200 is formed as in FIGS. 23(a) and 23(b). In other words, as shown in FIG. 22, an upper electrode pattern 205 is formed from a part corresponding to the electric element forming part 103 on the lower substrate 100 to a part near the outer periphery of the upper substrate 200, and the upper electrode pattern 205 is coated with conductive ink only near the outer periphery of the upper substrate 200 to form the second auxiliary electrode layer 204. Moreover, an upper insulating layer pattern 206 is formed on the upper electrode pattern 205 and an alignment layer 207 is formed thereon.

As shown in FIG. 23(c), the lower substrate 100 on which the first auxiliary electrode layer 104 is applied later to the lower electrode pattern 105 and the upper substrate 200 on which the second auxiliary electrode layer 204 is applied later to the upper electrode pattern 205 are bonded to each other with an adhesive layer 400 in a state in which a liquid crystal 300 is interposed between the lower substrate 100 and the upper substrate 200. FIG. 24 is an enlarged perspective view in which the bonded lower substrate 100 and upper substrate 200 are cut at a position on the first auxiliary electrode layer 104. FIG. 25 is an enlarged sectional view in which the bonded lower substrate 100 and upper substrate 200 are cut at a position on the upper electrode pattern 205.

Even in the case where the first and second auxiliary electrode layers 104 and 204 are applied later, as in the third embodiment, the end faces of the first auxiliary electrode layer 104 and the lower electrode pattern 105 of the lower substrate 100 are exposed on a lens end 302 of the lens 1 and the end faces of the second auxiliary electrode layer 204 and the upper electrode pattern 205 of the upper substrate 200

are exposed on the lens end **302** because the lower and upper substrates **100** and **200** are cut along a cutting line **301** as shown in FIG. **15**. Other points are similar to those of the third embodiment.

The lower insulating pattern **106** and the upper insulating pattern **206** may be formed over the substrates. Therefore, the lower insulating pattern **106** and the upper insulating pattern **206** can be formed by sputtering without using a mask.

Fifth Embodiment

In the third embodiment, the first auxiliary electrode layer **104** is formed on the smooth surface of the lower substrate **100** and the second auxiliary electrode layer **204** is formed on the smooth surface of the upper substrate **200**, whereas in a fifth embodiment, as shown in FIG. **26**, a first recess **102** is formed on a surface **101** of a lower substrate **100** and a second recess **202** is formed on a surface **201** of an upper substrate **200** such that first and second auxiliary electrode layers **104** and **204** can be correctly patterned at predetermined positions even when ITO ink having high wettability is used.

FIGS. **26** to **36** show a method for manufacturing a lens **1** for electronic spectacles.

FIG. **26** shows an exploded image of the completed lens **1** for better understanding of the manufacturing process. The lens **1** contains a liquid crystal **300** serving as an electric element between the lower substrate **100** and the upper substrate **200**. Reference numeral **400** denotes an adhesive layer for joining the lower substrate **100** and the upper substrate **200**.

FIGS. **27** and **28** show a process for fabricating the lower substrate **100**.

In FIG. **27(a)**, the first recess **102** and an electric element forming part **103** are formed on the surface **101** of the lower substrate **100** as shown in FIG. **28(a)**. The surface **101** is opposed to the upper substrate **200** and the liquid crystal **400** is placed on the electric element forming part **103** later. The first recess **102** is formed by transferring a convex formed on a resin molding die of the lower substrate **100**. The first recess **102** can be formed after molding. The first recess **102** is preferably about 0.5 mm to 2 mm in width and about 10 mm to 20 mm in length. Further, the first recess **102** has a depth of about several tens μm to several hundreds μm .

In FIG. **27(b)**, the first recess **102** is coated with conductive ink to form the first auxiliary electrode layer **104** as shown in FIG. **28(b)**. The first auxiliary electrode layer **104** is preferably at least 1 μm in thickness. To be specific, the first recess **102** is filled with ITO ink that is conductive ink. The ITO ink may be applied by an ink-jet method or a dispenser. The surface of the first recess **102** formed on the surface **101** of the lower substrate **100** is coated with the ITO ink to form the first auxiliary electrode layer **104**. Thus even when ITO ink having high wettability is used, it is possible to correctly pattern the first auxiliary electrode layer **104** at a predetermined position on the lower substrate **100**.

The first auxiliary electrode layer **104** can be formed also by spin coating or dipping in a state in which a part other than the first recess **102** is masked with tape and the like.

In FIG. **27(c)**, a lower electrode pattern **105** is formed on the electric element forming part **103** and the first auxiliary electrode layer **104**. The lower electrode pattern **105** connects the electric element forming part **103** and the first auxiliary electrode layer **104** so as to cover the first auxiliary electrode layer **104** as shown in FIG. **28(c)**. To be specific, ITO sputtering is performed using a mask pattern connecting

the electric element forming part **103** and the first recess **102**. The lower electrode pattern **105** is about 10 nm to 40 nm in thickness.

In FIG. **27(d)**, a lower insulating layer pattern **106** is formed on the electric element forming part **103** and the lower electrode pattern **105** as shown in FIG. **28(d)**. To be specific, after ITO sputtering in FIG. **27(c)**, SiO_2 is continuously sputtered without removing the lower substrate **100** from a chamber (without exposing the lower substrate **100** to the atmosphere). Such sputtering can be performed by a sputtering apparatus having multiple targets in a single chamber and thus a special apparatus is not necessary.

In FIG. **27(e)**, an alignment layer **107** is applied to a part to be coated with the liquid crystal **300**, and rubbing is performed thereon.

FIGS. **29** and **30** show a process for fabricating the upper substrate **200**.

In FIG. **29(a)**, the second recess **202** is formed on the surface **201** of the upper substrate **200** as shown in FIG. **30(a)**. The surface **201** is opposed to the lower substrate **100**. The second recess **202** is formed by transferring a convex formed on a resin molding die of the upper substrate **200**. The second recess **202** can be formed after molding. The second recess **202** is preferably about 0.5 mm to 2 mm in width and about 10 mm to 20 mm in length. Further, the second recess **202** has a depth of about several tens μm to several hundreds μm .

In FIG. **29(b)**, the second recess **202** is coated with conductive ink to form the second auxiliary electrode layer **204** as shown in FIG. **30(b)**. The second auxiliary electrode layer **204** is preferably at least 1 μm in thickness. To be specific, the second recess **202** is filled with ITO ink that is conductive ink. The ITO ink may be applied by the ink-jet method or a dispenser. The surface of the second recess **202** formed on the surface **201** of the upper substrate **200** is coated with the ITO ink to form the second auxiliary electrode layer **204**. Thus even when ITO ink having high wettability is used, it is possible to correctly pattern the second auxiliary electrode layer **204** at a predetermined position on the upper substrate **200**.

The second auxiliary electrode layer **204** can be formed also by spin coating or dipping in a state in which a part other than the second recess **202** is masked with tape and the like.

In FIG. **29(c)**, an upper electrode pattern **205** is formed on a part **203** corresponding to the electric element forming part **103** on the lower substrate **100** and the second auxiliary electrode layer **204** as shown in FIG. **30(c)**. The upper electrode pattern **205** connects the part **203** and the second auxiliary electrode layer **204** so as to cover the second auxiliary electrode layer **204**. To be specific, ITO sputtering is performed using a mask pattern connecting the part **203** and the second recess **202**. The upper electrode pattern **205** is about 10 nm to 40 nm in thickness.

In FIG. **29(d)**, an upper insulating layer pattern **206** is formed on the upper electrode pattern **205** as shown in FIG. **30(d)**. To be specific, after ITO sputtering in FIG. **29(c)**, SiO_2 is continuously sputtered without removing the upper substrate **200** from a chamber device (without exposing the upper substrate **200** to the atmosphere). Such sputtering can be performed by a sputtering apparatus having multiple targets in a single chamber and thus a special apparatus is not necessary.

In FIG. **29(e)**, an alignment layer **207** is applied to a part of the upper electrode pattern **205** so as to correspond to the part **203**, and rubbing is performed thereon.

17

The lower substrate **100** and the upper substrate **200** are bonded with the adhesive layer **400** in a state in which the liquid crystal **300** serving as the electric element is interposed between the electric element forming part **103** of the lower substrate **100** fabricated thus and the upper substrate **200**. To be specific, the liquid crystal **300** is applied by a dispenser or the ink-jet method. After the liquid crystal **300** is applied, an adhesive (sealing agent) is applied around the liquid crystal **300** and then the lower substrate **100** and the upper substrate **200** are bonded with the adhesive layer **400**.

FIG. **31** is an enlarged perspective view in which the bonded lower substrate **100** and upper substrate **200** are cut at a position on the first recess **102**. FIG. **32** is an enlarged view of the principle part of FIG. **31**. FIG. **33** is an enlarged perspective view in which the bonded lower substrate **100** and upper substrate **200** are cut at a position on the second recess **202**. FIG. **34** is an enlarged view of the principle part of FIG. **33**.

As in FIG. **15**, the lower substrate **100** and the upper substrate **200** that have been bonded thus are cut along a cutting line **301** according to the shape of a rim **8** of a spectacle frame **11**. In this case, the substrates **100** and **200** are cut at the first and second recesses **102** and **202** and the cut surfaces of the first and second recesses **102** and **202** are exposed on a lens end **302** as shown in FIG. **35**. As shown in FIG. **36**, on the exposed cut surfaces of the first and second recesses **102** and **202**, the end faces of the first auxiliary electrode layer **104** and the lower electrode pattern **105** of the lower substrate **100** are exposed and the end faces of the second auxiliary electrode layer **204** and the upper electrode pattern **205** of the upper substrate **200** are exposed.

As shown in FIGS. **18** and **19**, the electronic spectacles can be constructed using the lens of FIG. **35**. The lenses **1** are set in the spectacle frame **11**.

With this configuration, a voltage for driving the liquid crystal **300** can be applied between the lower electrode pattern **105** and the upper electrode pattern **205** of the lens **1** from the control unit **5**.

In the case where the first and second recesses **102** and **202** are coated with the first and second auxiliary electrode layers **104** and **204** and then the lower electrode pattern **105** and the upper electrode pattern **205** are formed thereon, the lower insulating layer pattern **106** and the upper insulating layer pattern **206** can be formed, as previously mentioned, on the lower electrode pattern **105** and the upper electrode pattern **205** by continuous sputtering without removing the lower substrate **100** and the upper substrate **200** from the chamber opened to the atmosphere.

To be specific, in the case where the lower electrode pattern **105** and the upper electrode pattern **205** are formed on the first and second recesses **102** and **202** and then the lower electrode pattern **105** and the upper electrode pattern **205** are coated with the first and second auxiliary electrode layers **104** and **204**, the lower electrode pattern **105** and the upper electrode pattern **205** are formed on the first and second recesses **102** and **202** by sputtering, the sputtering apparatus is opened to the atmosphere to remove the lower substrate **100** and the upper substrate **200**, the mask pattern is changed, and then the lower insulating layer pattern **106** and the upper insulating layer pattern **206** are formed. In another method, the lower electrode pattern **105** and the upper electrode pattern **205** are formed on the first and second recesses **102** and **202** by sputtering, the sputtering apparatus is opened to the atmosphere to remove the lower substrate **100** and the upper substrate **200**, the first and second auxiliary electrodes **104** and **204** are formed, and then sputtering is performed again. In both of the methods,

18

however, vacuum drawing performed twice in the sputtering apparatus results in a complicated fabrication process.

In the present embodiment, the first and second auxiliary electrode layers **104** and **204** are first applied. In this case, the lower electrode pattern **105** and the lower insulating layer pattern **106** can be formed on the lower substrate **100** without opening the sputtering apparatus to the atmosphere, and the upper electrode pattern **205** and the upper insulating layer pattern **206** can be formed on the upper substrate **200** without opening the sputtering apparatus to the atmosphere, thereby achieving a simple fabrication process.

As in FIGS. **20** and **21**, it is more preferable to apply silver pastes **303a** and **303b** that are conductive pastes onto the first auxiliary electrode layer **104** and the second auxiliary electrode layer **204** because the silver pastes **303a** and **303b** increase the contact areas. The same advantage can be achieved as in the foregoing embodiments.

Sixth Embodiment

In the fourth embodiment, the first auxiliary electrode layer **104** is formed on the smooth surface of the lower substrate **100** and the second auxiliary electrode layer **204** is formed on the smooth surface of the upper substrate **200**, whereas in a sixth embodiment, as shown in FIG. **37**, a first recess **102** is formed on a surface **101** of a lower substrate **100** and a second recess **202** is formed on a surface **201** of an upper substrate **200** such that first and second auxiliary electrode layers **104** and **204** can be correctly patterned at predetermined positions even when ITO ink having high wettability is used.

FIGS. **37** to **40** show the sixth embodiment of the present invention.

In the fifth embodiment, the first recess **102** is coated with the first auxiliary electrode layer **104** and then the lower electrode pattern **105** is formed thereon, and the second recess **202** is coated with the second auxiliary electrode layer **204** and then the upper electrode pattern **205** is formed thereon. The sixth embodiment is different only in that the first and second auxiliary electrode layers **104** and **204** are applied later. Other points are similar to those of the fifth embodiment.

FIG. **37** shows an exploded image of a completed lens **1** for better understanding of the manufacturing process.

In FIG. **38(a)**, a lower electrode pattern **105** is formed from an electric element forming part **103** to the first recess **102** of the lower substrate **100**.

In FIG. **38(b)**, the lower electrode pattern **105** is coated with conductive ink only in the first recess **102** to form the first auxiliary electrode layer **104**, and a lower insulating layer pattern **106** is formed so as to cover the first auxiliary electrode layer **104**, the lower electrode pattern **105**, and the electric element forming part **103**. As shown in FIG. **37**, an alignment layer **107** is formed on the lower insulating layer pattern **106** so as to correspond to the position of the electric element forming part **103**.

In this case, the upper substrate **200** is formed as in FIGS. **38(a)** and **38(b)**. In other words, as shown in FIG. **37**, an upper electrode pattern **205** is formed on a part corresponding to the electric element forming part **103** on the lower substrate **100**, the second recess **202**, and a part connecting the electric element forming part **103** and the second recess **202**. After that, the upper electrode pattern **205** is coated with conductive ink only in the second recess **202** to form the second auxiliary electrode layer **204**. Further, an upper insulating layer pattern **206** is formed so as to cover the

19

second auxiliary electrode layer **204** and the upper electrode pattern **205**. Moreover, an alignment layer **207** is formed thereon.

As shown in FIG. **38(c)**, the lower substrate **100** on which the first auxiliary electrode layer **104** is applied later onto the lower electrode pattern **105** in the first recess **102** and the upper substrate **200** on which the second auxiliary electrode layer **204** is applied later onto the upper electrode pattern **205** in the second recess **202** are bonded to each other with an adhesive layer **400** in a state in which a liquid crystal **300** is interposed between the lower substrate **100** and the upper substrate **200**. FIG. **39** is an enlarged perspective view in which the bonded lower substrate **100** and upper substrate **200** are cut at a position on the first recess **102**. FIG. **40** is an enlarged sectional view in which the bonded lower substrate **100** and upper substrate **200** are cut at a position on the second recess **202**.

Even when the first and second auxiliary electrode layers **104** and **204** are applied later onto the first and second recesses **102** and **202**, as in the fifth embodiment, the end faces of the first auxiliary electrode layer **104** and the lower electrode pattern **105** of the lower substrate **100** are exposed on a lens end **302** of the lens **1** and the end faces of the second auxiliary electrode layer **204** and the upper electrode pattern **205** of the upper substrate **200** are exposed on the lens end **302** because the lower and upper substrates **100** and **200** are cut along the cutting line **301** as in FIG. **35**. Other points are similar to those of the fifth embodiment.

In the sixth embodiment, the first auxiliary electrode layer **104** is formed on the recess of the lower electrode pattern **105** in the first recess **102** and the second auxiliary electrode layer **204** is formed on the recess of the upper electrode pattern **205** in the second recess **202**. Thus even when ITO ink having high wettability is used, it is possible to correctly pattern the first and second auxiliary electrode layers **104** and **204** at predetermined positions on the lower substrate **100** and the upper substrate **200**.

Further, the lower insulating pattern **106** and the upper insulating pattern **206** may be formed over the substrates, thereby forming insulating layers by sputtering without using a mask.

Seventh Embodiment

In the fourth embodiment, the first auxiliary electrode layer **104** is formed on the lower substrate **100** and then the lower insulating layer pattern **106** is formed thereon, and the second auxiliary electrode layer **204** is formed on the upper substrate **200** and then the upper insulating layer pattern **206** is formed thereon. A seventh embodiment is different only in that a hole **106b** (see FIG. **41**) is formed on a lower insulating layer pattern **106**, a hole **206b** (see FIG. **41**) is formed on an upper insulating layer pattern **206**, the lower insulating layer pattern **106** is formed before a first auxiliary electrode layer **104**, and the upper insulating layer pattern **206** is formed before a second auxiliary electrode layer **204**.

In the seventh embodiment, the hole **106b** of the lower insulating layer pattern **106** formed on a lower electrode pattern **105** is filled with conductive ink and the lower electrode pattern **105** is partially coated with the conductive ink. Thus even when ITO ink having high wettability is used, it is possible to correctly pattern the first auxiliary electrode layer **104** at a predetermined position. Similarly, the hole **206b** of the upper insulating layer pattern **206** formed on an upper electrode pattern **205** is filled with conductive ink and the upper electrode pattern **205** is partially coated with the conductive ink. Thus even when

20

ITO ink having high wettability is used, it is possible to correctly pattern the second auxiliary electrode layer **204** at a predetermined position. Other points are similar to those of the fourth embodiment.

Eighth Embodiment

In the sixth embodiment, the first auxiliary electrode layer **104** is formed on the lower substrate **100** and then the lower insulating layer pattern **106** is formed thereon, and the second auxiliary electrode layer **204** is formed on the upper substrate **200** and then the upper insulating layer pattern **206** is formed thereon. An eighth embodiment is different only in that a hole **106b** (see FIG. **42**) is formed on a lower insulating layer pattern **106**, a hole **206b** (see FIG. **42**) is formed on an upper insulating layer pattern **206**, the lower insulating layer pattern **106** is formed before a first auxiliary electrode layer **104**, and the upper insulating layer pattern **206** is formed before a second auxiliary electrode layer **204**.

In the eighth embodiment, the hole **106b** of the lower insulating layer pattern **106** formed on a lower electrode pattern **105** is filled with conductive ink and the lower electrode pattern **105** is partially coated with the conductive ink. Thus even when ITO ink having high wettability is used, it is possible to correctly pattern the first auxiliary electrode layer **104** at a predetermined position. Similarly, the hole **206b** of the upper insulating layer pattern **206** formed on an upper electrode pattern **205** is filled with conductive ink and the upper electrode pattern **205** is partially coated with the conductive ink. Thus even when ITO ink having high wettability is used, it is possible to correctly pattern the second auxiliary electrode layer **204** at a predetermined position. Other points are similar to those of the sixth embodiment.

In the fifth, sixth, and eighth embodiments, the first and second recesses **102** and **202** make it possible to correctly pattern highly wettable ink at the predetermined positions and prevent the ITO ink, which is conductive ink, from spreading to the bonded surfaces of the upper and lower substrates.

In the case where patterning is performed directly on the surfaces of the lower substrate **100** and the upper substrate **200** without providing the first and second recesses **102** and **202** as in the third, fourth, and seventh embodiments, a gap is formed between the bonded upper and lower substrates because of the thickness of the ITO ink that is conductive ink, thereby deforming the lens **1**. The fifth, sixth, and eighth embodiments make it possible to satisfactorily fabricate the lens **1** with less deformation.

In the fifth, sixth, and eighth embodiments, when the first and second recesses **102** and **202** are composed of flat surfaces in cross section, ink tends to gather at straight lines where the surfaces of the recess intersect with each other, so that the ink has a larger thickness in some portions than on the flat surfaces. In the portions where a liquid tends to gather, cracks are likely to occur owing to different dry states on the surface of an ITO ink film that is a conductive ink film, thereby increasing the resistance of a transparent conductive film formed of ITO ink. In order to solve this problem, the first and second recesses **102** and **202** of the fifth, sixth, and eighth embodiments are curved in cross section. When the first and second recesses **102** and **202** are not curved in cross section but are formed by joining flat surfaces in cross section, substantially the same effect can be expected by rounding the intersections of the flat surfaces.

In the third to eighth embodiments, the transparent first and second auxiliary electrode layers **104** and **204** are

formed by applying ITO ink that is conductive ink and the transparent lower electrode pattern **105** and upper electrode pattern **205** are formed by sputtering. The lower electrode pattern **105** and the upper electrode pattern **205** can be similarly formed by [vacuum] vapor deposition methods other than sputtering. The other [vacuum] vapor deposition methods include [CVD] PVD (*Physical Vapor Deposition*) methods such as resistance heating [vacuum] vapor deposition, electron beam [vacuum] vapor deposition, molecular beam epitaxy, ion plating and ion beam deposition, [PVD (*Physical Vapor Deposition*)] and chemical vapor deposition methods such as [ion beam deposition], thermal CVD (thermal Chemical Vapor Deposition), plasma CVD (plasma-enhanced chemical vapor deposition), optical CVD, epitaxial CVD, and atomic layer CVD.

Further, the transparent first and second auxiliary electrode layers **104** and **204**, the lower electrode pattern **105**, and the upper electrode pattern **205** are made of ITO (indium tin oxide) in the example of the foregoing explanation. The layers and patterns may be made of ITO substitute transparent electrode materials that include niobium-doped titanium dioxide ($Ti_{1-x}Nb_xO_2$; TNO) not containing indium but containing titanium as a major component, and ZnO.

In the third to eighth embodiments, the lower insulating layer pattern **106** and the upper insulating layer pattern **206** are provided. When the lower electrode pattern **105** and the upper electrode pattern **205** can be electrically insulated in a continuous manner by the adhesive layer **400** alone, at least one of the lower insulating layer pattern **106** and the upper insulating layer pattern **206** may be omitted.

INDUSTRIAL APPLICABILITY

Electronic spectacles according to the present invention ensure connection to an electric circuit and achieve higher reliability. Thus the present invention is useful for spectacles and sunglasses that use electric elements such as a liquid crystal element and an electrochromic element.

The invention claimed is:

[1. A method for manufacturing a lens for electronic spectacles,

in fabrication of the lens containing an electric element between a lower substrate and an upper substrate, the method comprising:

fabricating the lower substrate such that a first recess for lens electrode pads is formed on a surface of the lower substrate, the surface being opposed to the upper substrate,

the first recess is coated with conductive ink to form a transparent first auxiliary electrode layer, and

a transparent lower electrode pattern is formed on an electric element forming part of the lower substrate and the first auxiliary electrode layer by a vacuum deposition method so as to connect the electric element forming part and the first auxiliary electrode layer;

fabricating the upper substrate such that a second recess for the lens electrode pads is formed on a surface of the upper substrate, the surface being opposed to the lower substrate,

the second recess is coated with conductive ink to form a transparent second auxiliary electrode layer, and

a transparent upper electrode pattern is formed by the vacuum deposition method on a part corresponding to the electric element forming part on the upper substrate and the second auxiliary electrode layer so as to con-

nect the part corresponding to the electric element forming part and the second auxiliary electrode layer; and

joining the upper and lower substrates with the electric element interposed between the electric element forming part of the lower substrate and the upper substrate.]

2. [The method for manufacturing a lens for electronic spectacles according to claim **1**, further comprising.] *A method for manufacturing a lens for electronic spectacles, in fabrication of the lens containing an electric element between a lower substrate and an upper substrate, the method comprising:*

fabricating the lower substrate such that a first recess for lens electrode pads is formed on a surface of the lower substrate, the surface being opposed to the upper substrate;

coating the first recess with conductive ink to form a transparent first auxiliary electrode layer;

forming a transparent lower electrode pattern on an electric element forming part of the lower substrate and the first auxiliary electrode layer by a vapor deposition method so as to connect the electric element forming part and the first auxiliary electrode layer;

fabricating the upper substrate such that a second recess for the lens electrode pads is formed on a surface of the upper substrate, the surface being opposed to the lower substrate;

coating the second recess is coated with conductive ink to form a transparent second auxiliary electrode layer;

forming a transparent upper electrode pattern by the vapor deposition method on a part corresponding to the electric element forming part on the upper substrate and the second auxiliary electrode layer so as to connect the part corresponding to the electric element forming part and the second auxiliary electrode layer;

joining the upper and lower substrates with the electric element interposed between the electric element forming part of the lower substrate and the upper substrate; and

after joining the upper and lower substrates, cutting the upper and lower substrates at positions on the first and second recesses to expose cut surfaces of the first and second recesses on a lens end.

3. The method for manufacturing a lens for electronic spectacles according to claim **[1]** **2**, further comprising: after joining the upper and lower substrates, cutting the upper and lower substrates at positions on the first and second recesses to expose cut surfaces of the first and second recesses on a lens end; and

forming conductive paste on the exposed first and second recesses to form the lens electrode pad serving as an extraction electrode for the first auxiliary electrode layer and the lower electrode pattern and the lens electrode pad serving as an extraction electrode for the second auxiliary electrode layer and the upper electrode pattern.

[4. A method for manufacturing a lens for electronic spectacles,

in fabrication of the lens containing an electric element between a lower substrate and an upper substrate,

the method comprising:

fabricating the lower substrate such that a first recess for lens electrode pads is formed on a surface of the lower substrate, the surface being opposed to the upper substrate,

23

a lower electrode pattern is formed on an electric element forming part of the lower substrate and the first recess so as to connect the electric element forming part and the first recess, and

the lower electrode pattern of the first recess is coated with conductive ink to form a transparent first auxiliary electrode layer;

fabricating the upper substrate such that a transparent upper electrode pattern is formed by a vacuum deposition method on a part corresponding to the electric element forming part on the upper substrate and a second recess for the lens electrode pads so as to connect the part corresponding to the electric element forming part and the second recess, and

the upper electrode pattern of the second recess is coated with conductive ink to form a transparent second auxiliary electrode layer; and

joining the upper and lower substrates with the electric element interposed between the electric element forming part of the lower substrate and the upper substrate.]

5. [The method for manufacturing a lens for electronic spectacles according to claim 4, further comprising.] *A method for manufacturing a lens for electronic spectacles, in fabrication of the lens containing an electric element between a lower substrate and an upper substrate, the method comprising:*

fabricating the lower substrate such that a first recess for lens electrode pads is formed on a surface of the lower substrate, the surface being opposed to the upper substrate;

forming a lower electrode pattern on an electric element forming part of the lower substrate and the first recess so as to connect the electric element forming part and the first recess,

coating the lower electrode pattern of the first recess with conductive ink to form a transparent first auxiliary electrode layer;

fabricating the upper substrate such that a transparent upper electrode pattern is formed by a vapor deposition method on a part corresponding to the electric element forming part on the upper substrate and a second recess for the lens electrode pads so as to connect the part corresponding to the electric element forming part and the second recess;

coating the upper electrode pattern of the second recess with conductive ink to form a transparent second auxiliary electrode layer;

joining the upper and lower substrates with the electric element interposed between the electric element forming part of the lower substrate and the upper substrate; and

after joining the upper and lower substrates, cutting the upper and lower substrates at positions on the first and second recesses to expose cut surfaces of the first and second recesses on a lens end.

6. The method for manufacturing a lens for electronic spectacles according to claim [4] 5, further comprising: after joining the upper and lower substrates, cutting the upper and lower substrates at positions on the first and second recesses to expose cut surfaces of the first and second recesses on a lens end; and

forming conductive paste on the exposed first and second recesses to form the lens electrode pad serving as an extraction electrode for the first auxiliary electrode layer and the lower electrode pattern and the lens

24

electrode pad serving as an extraction electrode for the second auxiliary electrode layer and the upper electrode pattern.

[7. A method for manufacturing a lens for electronic spectacles, in fabrication of the lens containing an electric element between a lower substrate and an upper substrate, the method comprising:

fabricating the lower substrate such that a surface of the lower substrate is coated with conductive ink to form a transparent first auxiliary electrode layer for lens electrode pads, the surface being opposed to the upper substrate, and

a transparent lower electrode pattern is formed by a vacuum deposition method on an electric element forming part of the lower substrate and the first auxiliary electrode layer so as to connect the electric element forming part and the first auxiliary electrode layer;

fabricating the upper substrate such that a surface of the upper substrate is coated with the conductive ink to form a transparent second auxiliary electrode layer for the lens electrode pads, the surface being opposed to the lower substrate, and

a transparent upper electrode pattern is formed by the vacuum deposition method on a part corresponding to the electric element forming part on the upper substrate and the second auxiliary electrode layer so as to connect the part corresponding to the electric element forming part and the second auxiliary electrode layer; and

joining the upper and lower substrates with the electric element interposed between the electric element forming part of the lower substrate and the upper substrate.]

8. [The method for manufacturing a lens for electronic spectacles according to claim 7, further comprising.] *A method for manufacturing a lens for electronic spectacles, in fabrication of the lens containing an electric element between a lower substrate and an upper substrate, the method comprising:*

fabricating the lower substrate such that a surface of the lower substrate is coated with conductive ink to form a transparent first auxiliary electrode layer for lens electrode pads, the surface being opposed to the upper substrate;

forming a transparent lower electrode pattern by a vapor deposition method on an electric element forming part of the lower substrate and the first auxiliary electrode layer so as to connect the electric element forming part and the first auxiliary electrode layer;

fabricating the upper substrate such that a surface of the upper substrate is coated with the conductive ink to form a transparent second auxiliary electrode layer for the lens electrode pads, the surface being opposed to the lower substrate;

forming a transparent upper electrode pattern by the vapor deposition method on a part corresponding to the electric element forming part on the upper substrate and the second auxiliary electrode layer so as to connect the part corresponding to the electric element forming part and the second auxiliary electrode layer;

joining the upper and lower substrates with the electric element interposed between the electric element forming part of the lower substrate and the upper substrate; and

after joining the upper and lower substrates, cutting the upper and lower substrates at positions on an overlap portion of the first auxiliary electrode layer and the lower electrode pattern and an overlap portion of the

25

second auxiliary electrode layer and the upper electrode pattern to expose cut surfaces of the substrates.

9. The method for manufacturing a lens for electronic spectacles according to claim [7] 8, further comprising:

after joining the upper and lower substrates, cutting the upper and lower substrates at positions on an overlap portion of the first auxiliary electrode layer and the lower electrode pattern and an overlap portion of the second auxiliary electrode layer and the upper electrode pattern to expose cut surfaces of the substrates; and forming conductive paste on the overlap portion of the first auxiliary electrode layer and the lower electrode pattern and the overlap portion of the second auxiliary electrode layer and the upper electrode pattern to form the lens electrode pad serving as an extraction electrode for the first auxiliary electrode layer and the lower electrode pattern and the lens electrode pad serving as an extraction electrode for the second auxiliary electrode layer and the upper electrode pattern.

[10. A method for manufacturing a lens for electronic spectacles, in fabrication of the lens containing an electric element between a lower substrate and an upper substrate, the method comprising:

fabricating the lower substrate such that a transparent lower electrode pattern for applying a signal to an electric element forming part of the lower substrate is formed by a vacuum deposition method, and

one end of the lower electrode pattern is coated with conductive ink to form a transparent first auxiliary electrode layer;

fabricating the upper substrate such that a transparent upper electrode pattern is formed by the vacuum deposition method, the upper electrode pattern applying a signal to a part corresponding to the electric element forming part on the upper substrate, and

one end of the upper electrode pattern is coated with conductive ink to form a transparent second auxiliary electrode layer; and

joining the upper and lower substrates with the electric element interposed between the electric element forming part of the lower substrate and the upper substrate.]

11. [The method for manufacturing a lens for electronic spectacles according to claim 10, further comprising.] *A method for manufacturing a lens for electronic spectacles, in fabrication of the lens containing an electric element between a lower substrate and an upper substrate, the method comprising:*

fabricating the lower substrate such that a transparent lower electrode pattern for applying a signal to an electric element forming part of the lower substrate is formed by a vapor deposition method;

coating one end of the lower electrode pattern with conductive ink to form a transparent first auxiliary electrode layer;

fabricating the upper substrate such that a transparent upper electrode pattern is formed by the vapor deposition method, the upper electrode pattern applying a signal to a part corresponding to the electric element forming part on the upper substrate, and

coating one end of the upper electrode pattern with conductive ink to form a transparent second auxiliary electrode layer;

joining the upper and lower substrates with the electric element interposed between the electric element forming part of the lower substrate and the upper substrate; and

26

after joining the upper and lower substrates, cutting the upper and lower substrates at positions on an overlap portion of the first auxiliary electrode layer and the lower electrode pattern and an overlap portion of the second auxiliary electrode layer and the upper electrode pattern to expose cut surfaces of the substrates.

12. The method for manufacturing a lens for electronic spectacles according to claim [10] 11, further comprising:

after joining the upper and lower substrates, cutting the upper and lower substrates at positions on an overlap portion of the first auxiliary electrode layer and the lower electrode pattern and an overlap portion of the second auxiliary electrode layer and the upper electrode pattern to expose cut surfaces of the substrates; and

forming conductive paste on the overlap portion of the first auxiliary electrode layer and the lower electrode pattern and the overlap portion of the second auxiliary electrode layer and the upper electrode pattern to form the lens electrode pad serving as an extraction electrode for the first auxiliary electrode layer and the lower electrode pattern and the lens electrode pad serving as an extraction electrode for the second auxiliary electrode layer and the upper electrode pattern.

[13. A method for manufacturing a lens for electronic spectacles, in fabrication of the lens containing an electric element between a lower substrate and an upper substrate, the method comprising:

fabricating the lower substrate such that a transparent lower electrode pattern for applying a signal to an electric element forming part of the lower substrate is formed by a vacuum deposition method,

a lower insulating layer pattern is formed on the electric element forming part and the lower electrode pattern of the lower substrate except for a part to be coated with a first auxiliary electrode layer, and

a hole of the lower insulating layer pattern is coated with conductive ink to form the transparent first auxiliary electrode layer;

fabricating the upper substrate such that a transparent upper electrode pattern is formed by the vacuum deposition method, the upper electrode pattern applying a signal to a part corresponding to the electric element forming part on the upper substrate,

an upper insulating layer pattern is formed on the part corresponding to the electric element forming part on the upper substrate and on the upper electrode pattern except for a part to be coated with a second auxiliary electrode layer, and

a hole of the upper insulating layer pattern is coated with conductive ink to form the transparent second auxiliary electrode layer; and

joining the upper and lower substrates with the electric element interposed between the electric element forming part of the lower substrate and the upper substrate.]

[14. A method for manufacturing a lens for electronic spectacles, in fabrication of the lens containing an electric element between a lower substrate and an upper substrate, the method comprising:

fabricating the lower substrate such that a first recess for lens electrode pads is formed on a surface of the lower substrate, the surface being opposed to the upper substrate,

a lower electrode pattern is formed on an electric element forming part of the lower substrate and the first recess so as to connect the electric element forming part and the first recess,

27

a lower insulating layer pattern is formed on the electric element forming part and the lower electrode pattern of the lower substrate except for a part to be coated with a first auxiliary electrode layer, and

a hole of the lower insulating layer pattern is coated with conductive ink to form the transparent first auxiliary electrode layer;

fabricating the upper substrate such that a transparent upper electrode pattern is formed by a vacuum deposition method on a part corresponding to the electric element forming part on the upper substrate and a second recess for the lens electrode pads so as to connect the part corresponding to the electric element forming part and the second recess,

an upper insulating layer pattern is formed on the upper electrode pattern and the part corresponding to the electric element forming part on the upper substrate, except for a part to be coated with a second auxiliary electrode layer, and

a hole of the upper insulating layer pattern is coated with conductive ink to form the transparent second auxiliary electrode layer; and

joining the upper and lower substrates with the electric element interposed between the electric element forming part of the lower substrate and the upper substrate.]

15. A lens for electronic spectacles, the lens containing an electric element between two substrates, [wherein] *comprising:*

a first recess formed on one of the substrates; an electric element forming part formed on said one of the substrates apart from the first recess, with a liquid crystal element serving as the electric element placed on the electric element forming part; and

a lens electrode pad on one end of an electrode for applying a voltage to the electric element [is], *the lens electrode pad being exposed on a lens end, [and the lens electrode pad has the electrode formed in a recess on a bonded surface of one of the two substrates, the electrode being formed by stacking an auxiliary electrode layer formed of conductive ink and a lower electrode pattern formed by a vacuum deposition method]*

wherein the electrode is formed by stacking an auxiliary electrode layer formed of conductive ink and an electrode pattern formed by a vapor deposition method in the first recess,

wherein a second recess is formed on the other of the substrates at a position not facing the first recess, with a second electrode provided in the second recess, and wherein the electrode pattern extends to the electric element forming part.

16. The lens for electronic spectacles according to claim 15, wherein the *first recess* is exposed on the lens end as a curved surface.

[17. A lens for electronic spectacles, the lens containing an electric element between two substrates, wherein an electrode for applying a voltage to the electric element has one end exposed on a lens end, and the one end of the

28

electrode is formed by stacking an auxiliary electrode layer formed of conductive ink and a lower electrode pattern formed by a vacuum deposition method.]

[18. Electronic spectacles in which a lens containing an electric element is set in a spectacle frame,

the lens having lens electrode pads exposed on a lens end, the lens electrode pads being disposed on one end of an electrode for applying a voltage to the electric element, the spectacle frame including an electric connector having one end connected to a control unit for controlling the electric element, the electric connector having wiring electrode pads disposed on an other end of the electric connector so as to correspond to positions of the lens electrode pads of the lens,

the electronic spectacles having anisotropic conductive rubber interposed between the wiring electrode pad of the electric connector and the lens electrode pad of the lens.]

[19. The electronic spectacles according to claim 18, further comprising: a rim-side spot facing in a rim of the spectacle frame, the electric connector being placed in the rim-side spot facing; and

a lens-side spot facing on the lens end of the lens, the anisotropic conductive rubber being placed in the lens-side spot facing.]

[20. The electronic spectacles according to claim 18, wherein the electric connector passes through rim locks of the spectacle frame and is provided in the rim, and the wiring electrode pads are set in the rim of the spectacle frame.]

21. *The lens for electronic spectacles according to claim 15, wherein the electric element forming part is located at a center of the one substrate and the first recess is opened to an edge of the one substrate.*

22. *The lens for electronic spectacles according to claim 15, wherein the liquid crystal element is disposed at a center of the one substrate.*

23. *The lens for electronic spectacles according to claim 15, wherein the electrode pattern is formed over the electric element forming part and the first recess.*

24. *Electronic spectacles having a lens that contains an electric element, comprising:*

a substrate of the lens; an electric element forming part formed on the substrate and accepting the electric element;

a first recess apart from the accommodation recess on the substrate,

an auxiliary electrode layer formed of conductive material and disposed on the first recess; and

an electrode pattern formed by a vapor deposition method over the electric element and the auxiliary electrode layer;

wherein a second recess is formed on a second substrate of the lens at a position not facing the first recess, with a second electrode provided in the second recess, and wherein voltage is applied to the electric element via the auxiliary electrode layer and the electrode pattern.

* * * * *