

(19) World Intellectual Property Organization
International Bureau



(43) International Publication Date
11 March 2010 (11.03.2010)

(10) International Publication Number
WO 2010/028065 A2

- (51) **International Patent Classification:**
G02B 27/01 (2006.01)
- (21) **International Application Number:**
PCT/US2009/055758
- (22) **International Filing Date:**
2 September 2009 (02.09.2009)
- (25) **Filing Language:** English
- (26) **Publication Language:** English
- (30) **Priority Data:**
12/204,567 4 September 2008 (04.09.2008) US
- (71) **Applicant (for all designated States except US):** IN-NOVEGA INC. [US/US]; 4888 N.E. Sheltered Bay Lane, Hansville, Washington 98340 (US).
- (72) **Inventor; and**
- (75) **Inventor/Applicant (for US only):** SPRAGUE, Randall B. [US/US]; 4888 N.E. Sheltered Bay Lane, Hansville, Washington 98340 (US).
- (74) **Agents:** VIKSNINS, Ann S. et al.; Viksnins Harris & Padys PLLP, P.O. Box 111098, Saint Paul, Minnesota 55111-1098 (US).

- (81) **Designated States (unless otherwise indicated, for every kind of national protection available):** AE, AG, AL, AM, AO, AT, AU, AZ, BA, BB, BG, BH, BR, BW, BY, BZ, CA, CH, CL, CN, CO, CR, CU, CZ, DE, DK, DM, DO, DZ, EC, EE, EG, ES, FI, GB, GD, GE, GH, GM, GT, HN, HR, HU, ID, IL, IN, IS, JP, KE, KG, KM, KN, KP, KR, KZ, LA, LC, LK, LR, LS, LT, LU, LY, MA, MD, ME, MG, MK, MN, MW, MX, MY, MZ, NA, NG, NI, NO, NZ, OM, PE, PG, PH, PL, PT, RO, RS, RU, SC, SD, SE, SG, SK, SL, SM, ST, SV, SY, TJ, TM, TN, TR, TT, TZ, UA, UG, US, UZ, VC, VN, ZA, ZM, ZW.
- (84) **Designated States (unless otherwise indicated, for every kind of regional protection available):** ARIPO (BW, GH, GM, KE, LS, MW, MZ, NA, SD, SL, SZ, TZ, UG, ZM, ZW), Eurasian (AM, AZ, BY, KG, KZ, MD, RU, TJ, TM), European (AT, BE, BG, CH, CY, CZ, DE, DK, EE, ES, FI, FR, GB, GR, HR, HU, IE, IS, IT, LT, LU, LV, MC, MK, MT, NL, NO, PL, PT, RO, SE, SI, SK, SM, TR), OAPI (BF, BJ, CF, CG, CI, CM, GA, GN, GQ, GW, ML, MR, NE, SN, TD, TG).

Published:

- without international search report and to be republished upon receipt of that report (Rule 48.2(g))

(54) **Title:** METHOD AND APPARATUS TO PROCESS DISPLAY AND NON-DISPLAY INFORMATION

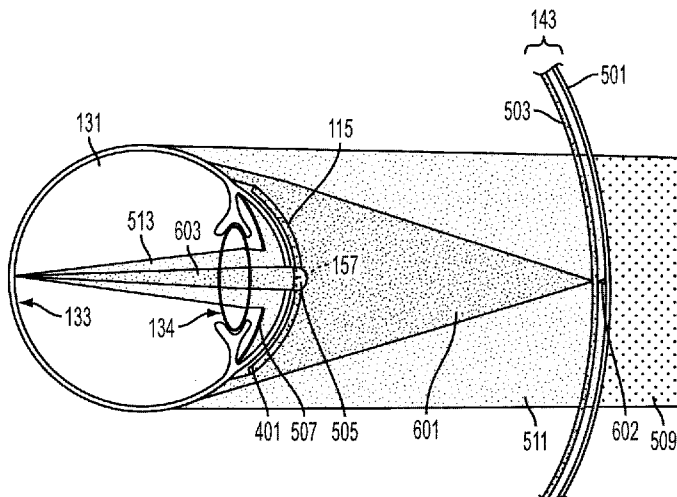

FIG. 7

(57) **Abstract:** In some embodiments, an apparatus includes a substrate including a display information optical path to receive display information and includes a non-display information optical path to receive non-display information. In some embodiments, the display information optical path includes a display information optical power. In some embodiments, the non-display information optical path includes one or more filters and a non-display information optical power.



WO 2010/028065 A2

METHOD AND APPARATUS TO PROCESS DISPLAY AND NON-DISPLAY INFORMATION

5

Priority of Invention

This application claims priority to United States Patent Application Number 12/204,567 that was filed on 04 September 2008. The entire content of this application is hereby incorporated herein by reference.

10

Field

The subject matter is related to optical processing of display information and non-display information.

Background

Current systems for optical processing of display information provided by a head-mounted display and non-display information provided by objects other than the head-mounted display may have characteristics that make them unattractive solutions for some applications. The twin requirements of a large field of view and a comfortable eye-to-system distance for the viewer results in multi-component optical systems where the final optical component has a large diameter. Such systems tend to be large and bulky and ill suited for applications where little space is available for processing the display information and the non-display information. For example, such systems are unattractive solutions for processing display and non-display information in a fighter pilot's helmet where the space for the optical system is limited.

20

Brief Description of the Drawings

An understanding of the apparatus and methods will now be had upon reference to the following detailed description, when read in conjunction with the accompanying drawings, where like reference characters refer to like parts throughout the several views, and in which:

25

Fig. 1A shows a block diagram of an apparatus to receive and process display information and non-display information in accordance with some embodiments;

30

Fig. 1B shows a block diagram of the apparatus (shown in Fig. 1A) coupled to a human visual system in accordance with some embodiments;

Fig. 1C shows a block diagram of an apparatus including the apparatus (shown in Fig. 1A), and further including a display to provide the display information in accordance with some embodiments;

35

Fig. 1D shows a block diagram of an apparatus including the apparatus

(shown in Fig. 1A), wherein at least one of the one or more filters (shown in Fig. 1A) includes a non-display path notch filter or a non-display path polarizing filter and further including the display (shown in Fig. 1C) to provide the display information (shown in Fig. 1A) in accordance with some embodiments;

5 Fig. 1E shows a block diagram of an apparatus including the apparatus (shown in Fig. 1A), wherein the one or more filters include a non-display path polarizing filter (shown in Fig. 1D) and further including the display (shown in Fig. 1C) in accordance with some embodiments;

Fig. 2A shows a block diagram of an apparatus to receive and process the display information and the non-display information in accordance with some embodiments;

10 Fig. 2B shows a block diagram of the apparatus (shown in Fig. 2A) coupled to the human visual system (shown in Fig. 1B) in accordance with some embodiments;

Fig. 2C shows a block diagram of an apparatus including the apparatus (shown in Fig. 2A), and further including the display (shown in Fig. 1C) to provide the display information in accordance with some embodiments;

15 Fig. 2D shows a block diagram of an apparatus including the apparatus (shown in Fig. 2A), wherein at least one of the one or more controllable optical materials includes a photochromic material or an electrochromic material and further including the display (shown in Fig. 1C) to provide the display information and one or more optical material activation signals in accordance with some embodiments;

20 Fig. 3 shows an apparatus including a substrate including an optical path having one or more zone plates to receive display information and non-display information in accordance with some embodiments;

Figs. 4A and 4B (diametrical section of contact lens shown in 4A) show illustrations of a contact lens including the display information optical path and the
25 non-display information optical path in accordance with some embodiments;

Fig. 5 shows an illustration of the display optically coupled by the contact lens to the human visual system to illustrate processing non-display information using wavelength filters in accordance with some embodiments;

30 Fig. 6 shows an illustration of the display optically coupled by the contact lens to the human visual system to illustrate processing display information using wavelength filters in accordance with some embodiments;

Fig. 7 shows an illustration of the display optically coupled by the contact lens to the human visual system to illustrate processing to combine non-display information and display information using wavelength filters in accordance with some embodiments;

Fig. 8 shows an illustration of the display optically coupled by the contact lens to the human visual system to illustrate processing non-display information using polarizing filters in accordance with some embodiments;

5 Fig. 9 shows an illustration of the display optically coupled by the contact lens to the human visual system to illustrate processing display information using polarizing filters in accordance with some embodiments;

Figs. 10A and 10B (diametrical section of illustration shown in 10A) show illustrations of a contact lens including one or more zone plate filters in accordance with some embodiments;

10 Fig. 11 shows an illustration of the display optically coupled by the contact lens to the human visual system to illustrate processing display information and non-display information using the one or more zone plate filters in accordance with some embodiments;

Fig. 12 shows an illustration of an apparatus including a substrate, a substantially transparent pixel unit, and an organic light emitting diode unit in accordance with some embodiments;

15 Fig. 13 shows a flow diagram of a method including enabling and disabling transmission of display information and transmission of non-display information in accordance with some embodiments; and

20 Fig. 14 shows a flow diagram of a method including polarizing display and non-display information and illuminating a contact lens with the polarized display and non-display information in accordance with some embodiments.

Description

The term substrate as used in the following description includes any material or substance used to form an optical component such as a contact lens. The term zone plate includes an optical component that focuses light by diffraction. The term display information optical path includes the optical path traversed in a substrate by display information. The term non-display information optical path includes the optical path traversed in a substrate by non-display information. The term optically coupled includes two or more optical components connect by an optical path.

30 The term non-display information path optical power includes the optical power provided in a substrate for an optical signal passing through the non-display information path. The term substantially zero power includes an optical power that has substantially no effect on an optical signal. The term normal power is the optical power necessary to provide correction in an optical system, such as a human visual system, for defects in the optical system. The term close power is the optical power necessary to provide correction in an optical system, such as a
35 human visual system, for viewing at a close distance.

The term electromagnetic radiation includes energy in the form of transverse electric and magnetic waves. The term electromagnetic radiation includes electromagnetic radiation in the visible spectrum. The term illuminating includes directing or transmitting electromagnetic radiation to a target.

5 The term filter includes apparatus or methods for selectively transmitting electromagnetic radiation. The term characteristic feature includes detectable traits, such as narrow bandwidth or polarization, by which signals can be distinguished.

The term notch filter includes a filter that blocks electromagnetic radiation over a substantially continuous narrow band of frequencies. The term non-display path notch filter
10 includes a notch filter included in the non-display path of a substrate.

The term bandpass filter includes a filter that transmits electromagnetic radiation over a substantially continuous but finite band of frequencies. The term display path bandpass filter includes a bandpass filter included in the display path of a substrate.

The term polarizing filter includes a filter that polarizes electromagnetic radiation. The
15 term display path polarizing filter includes a polarizing filter included in the display information path of a substrate. The term non-display path polarizing filter includes a polarizing filter included in the non-display information path of a substrate. The term shutter includes a controllable polarizing filter. The term substantially opaque filter includes a filter that blocks all or nearly all of the information received by the filter.

20 The term display includes any apparatus capable of generating information in the form of electromagnetic radiation. The term organic light emitting diode display includes one or more light-emitting diodes whose light emitting layer is includes a film of one or more organic compounds. The term display information includes information provided by a display.

The term controllable optical materials includes materials whose optical properties, such
25 as opacity, can be controlled. The term photochromic material includes materials whose optical properties can be controlled by an optical signal. The term electrochromic material includes an optical material whose properties can be controlled by an electrical signal. The term optical material activation signal includes signals to control the optical properties of a controllable optical material.

30 The term a pattern of pixel sites includes the organization of pixel sites on a substrate. The term substantial transparent pixel unit includes a portion of a display that transmits electromagnetic radiation generated outside the display. The term checkerboard pattern includes an alternating pattern similar to the pattern of a checkerboard.

In some embodiments, as illustrated and described herein, information provided by a
35 head-mounted display, referred to as display information, and information provided by objects

other than the head-mounted display, referred to as non-display information, are received at a contact lens included in a human visual system. A head-mounted display may include an organic light emitting diode display to provide the display information. The contact lens in combination with the human visual system provides images of the display information and the non-display information to the retina of the human visual system. The display information may include, for example, text information, non-text information or other visual information. The non-display information may include, for example, landscape information, non-landscape information, and other visual information.

The contact lens includes a display information optical path and a non-display information optical path. The display information optical path provides a contact lens transmission path between the head-mounted display and the human visual system for the display information transmitted by the head-mounted display. The display information optical path forms a substantially cylindrical central region of the contact lens. The display information optical path in the contact lens can provide power to assist the human visual system in focusing objects positioned close to the human lens.

The non-display information optical path provides a contact lens transmission path between the source of the non-display information and the human visual system for the non-display information. The non-display information optical path forms a substantially annular ring surrounding the cylindrical central region of the display information optical path. A filter is included in the non-display information optical path to substantially block display information from being transmitted through the non-display information optical path. The non-display information optical path in the contact lens may provide correction for defects, such as nearsightedness, farsightedness, and astigmatism in the human visual system.

The display information and the non-display information may be polarized to different polarizations to provide for distinguishing between the display information and the non-display information. Polarizing the display information and the non-display information enables independent processing of the display information and non-display information at the contact lens and enables time-domain multiplexing in the transmission of the display information and the non-display information to the contact lens. The time-domain multiplexed display information and non-display information when processed by the human visual system are perceived as a single image. Further detailed description of these and other embodiments is provided below.

Fig. 1A shows a block diagram of an apparatus 101 to receive and process display information 103 and non-display information 105 in accordance with some embodiments.

The apparatus 101 includes a substrate 107 including a display information optical path 109 to receive the display information 103 and including a non-display information optical path 111 to receive the non-display information 105. The display information optical path 109 includes a display information path optical power 113. The non-display information optical path 111 includes one or more filters 115 and a non-display information path optical power 117.

The substrate 107 is not limited to being formed from a particular material or combination of materials. Materials suitable for use in forming optical components, such as lenses, may be used in forming the substrate 107. Exemplary materials suitable for use in forming the substrate 107 include gels, such as silicone hydrogels, glasses, plastics, and polymers, such as polymethyl methacrylate and polycarbonate. The substrate 107 is not limited to a particular type of optical component. In some embodiments, the substrate 107 includes a substrate or blank suitable for forming one lens, such as a contact lens. In some embodiments, the substrate 107 includes one or more optical components or lenses, such as focusing lenses, formed from one or more optical materials. In some embodiments, the substrate 107 is formed from a flexible material conformable to the shape of a human cornea. In some embodiments, the substrate 107 is formed by filling a contact lens mold with one or more liquid polymers.

The display information 103 includes electromagnetic radiation, such as visible light, having at least one characteristic feature lacking in the non-display electromagnetic radiation of the non-display information 105. For example, in some embodiments, the display information 103 includes electromagnetic radiation having a narrow spectral bandwidth while the non-display information 105 includes electromagnetic radiation having a broad spectral bandwidth. Narrow spectral bandwidth and broad spectral bandwidth are relative terms. In some embodiments, for two signals, the signal having the narrower spectral bandwidth information is the signal having a narrow spectral bandwidth and the signal having the broader spectral bandwidth information is the signal having a broad spectral bandwidth. In some embodiments, narrow spectral bandwidth information includes information having a bandwidth of between about a few nanometers and a few tens of nanometers. In some embodiments, broad spectral bandwidth information includes information having a bandwidth greater than about a few tens of nanometers. Thus, the non-display electromagnetic radiation having a broad spectral bandwidth lacks the characteristic feature -- narrow spectral bandwidth -- included in the display information 103.

As a second example, in some embodiments, the display information 103 includes electromagnetic radiation having a display information polarization, such as right-handed circular polarization, and the non-display information 105 includes unpolarized information. Thus, the non-display information 105 including the non-display electromagnetic radiation

having the unpolarized information lacks the characteristic feature -- right handed circular polarization -- included in the display information 103.

The display information optical path 109 is included in the substrate 107 and is formed from an optical material or combination of materials. The display information optical path 109 is not limited to being formed from a particular optical material or combination of materials. Materials suitable for use in forming the substrate 107 are suitable for use in forming the display information optical path 109. The materials used to form the display information optical path 109 may differ from the one or more materials used to form the substrate 107.

In operation, the display information optical path 109 receives and transmits electromagnetic information, such as the display information 103. When coupled to a human visual system (as shown in Fig. 1B), the display information optical path 109 receives the display information 103 and assists the human visual system to substantially focus the display information 103 to a retina in the human visual system.

The non-display information optical path 111 is included in the substrate 107 and is formed from an optical material or combination of materials. The non-display information optical path 111 is not limited to being formed from a particular optical material or combination of materials. Materials suitable for use in forming the substrate 107 are suitable for use in forming the non-display information optical path 111. The materials used to form the non-display information optical path 111 may differ from the one or more materials used to form the substrate 107.

In operation, the non-display information optical path 111 receives the non-display information 105 and when coupled to a human visual system (as shown in Fig. 1B) substantially focuses the non-display information 105 to a retina in the human visual system. The non-display information 105 includes any information, such as visible objects, not included in the display information 103. In some embodiments, the non-display information 105 is provided from objects more distant from the human visual system than the source of the display information 103. For example, in some embodiments, the display information 103 is provided to a human visual system from a head-mounted display located between about 5 millimeters and about 200 millimeters from the cornea and the non-display information 105 is provided to the human visual system from a source located at a distance of greater than about 200 millimeters from the cornea.

The one or more filters 115 included in the non-display information optical path 111 substantially block the display information 103 while substantially transmitting the non-display information 105. Each of the one or more filters 115 is sensitive to a physical characteristic, such as wavelength, frequency, or polarization, of the display information 103. Thus, the one or

more filters 115 may include any filter or combination of filters or other optical components capable of substantially blocking the display information 103 while substantially transmitting the non-display information 105.

5 Optical power is the degree to which a lens or mirror converges or diverges light or electromagnetic radiation. A lens or mirror having substantially zero optical power neither converges nor diverges electromagnetic radiation. Normal power is the power necessary to provide correction in an optical system, such as a human visual system, for defects in the optical system. For example, normal power includes a power to correct for nearsightedness, farsightedness, or astigmatism in a human visual system. In some embodiments, a normal
10 power is between about .25 and about 10 diopters.

Close power is the power necessary to provide correction in an optical system, such as a human visual system, for viewing at a close distance. In a human visual system, a close distance is a distance of less than about 250 millimeters. For objects closer than about 250 millimeters, the human visual system cannot form a sharp image on the retina. A focusing lens can provide
15 close power to assist a human visual system in viewing objects at distances of less than about 250 millimeters. In some embodiments, the close power is between about 5 and about 200 diopters.

In some embodiments, the apparatus 101 includes combinations of optical powers. First, in some embodiments, the display information path optical power 113 includes substantially
20 zero power and the non-display information path optical power 117 includes substantially zero power. Second, in some embodiments, the display information path optical power 113 includes substantially zero power and the non-display information path optical power 117 includes a normal power. Third, in some embodiments, the display information path optical power 113 includes a close power and the non-display information path optical power 117 includes
25 substantially zero power. Fourth, in some embodiments, the display information path optical power 113 includes a close power and the non-display information path optical power 117 includes normal power.

Fig. 1B shows a block diagram of the apparatus 101 (shown in Fig. 1A) coupled to a human visual system 131 in accordance with some embodiments. The apparatus 101 (dashed
30 lines) includes the substrate 107 including the display information optical path 109 to receive the display information 103 and including the non-display information optical path 111 to receive the non-display information 105. The display information optical path 109 includes the display information path optical power 113. The non-display information optical path 111 includes the one or more filters 115 and the non-display information path optical power 117.

In some embodiments, the display information optical path 109 has an aperture 119. The aperture 119 may be sized to assist in focusing the display information 103. In some embodiments, the aperture 119 is sized to increase the depth of focus in the display information optical path 109. In some embodiments, the aperture 119 has a diameter of about one
5 millimeter.

In operation, the display information optical path 109 and the non-display information optical path 111 assist the human visual system 131 in forming a focused image of the display information 103 and a focused image of the non-display information 105 on a retina 133. The display information optical path 109 in cooperation with the human visual system 131, including
10 the human lens 134, substantially focuses the display information 103 to the retina 133 to form retinal display information image 135. The non-display information optical path 111 in cooperation with the human visual system 131, including the human lens 134, substantially focuses the non-display information 105 to the retina 133 to form retinal non-display information image 137. At least one of the one or more filters 115 in the non-display
15 information optical path 111 substantially blocks the display information 103 from entering the human visual system 131 from the non-display information optical path 111.

Fig. 1C shows a block diagram of an apparatus 141 including the apparatus 101 (shown in Fig. 1A), and further including a display 143 to provide the display information 103 in accordance with some embodiments. The apparatus 101 (dashed lines)
20 includes the substrate 107 including the display information optical path 109 to receive the display information 103 and including the non-display information optical path 111 to receive the non-display information 105. The display information optical path 109 includes the display information path optical power 113. The non-display information optical path 111 includes the one or more filters 115 and the non-display information path optical power 117.

In some embodiments, the display information 103 includes information provided by the display 143. The display 143 includes any device or system that provides information in the form of electromagnetic radiation, such as visible light. For example, in some embodiments, the display information 103 is provided by a device including a single two-state source of visible
25 light.

The display 143 is not limited to a particular type of display. In some embodiments, the display 143 includes micro-displays and other small displays, such as displays having a thickness of between about 100 microns and about two millimeters, flat screen displays, such as liquid crystal displays, and cathode ray tube displays. In some embodiments, the display 143 is mounted in an eyeglass frame. In operation, in some embodiments, the distance between the
30 display and a human cornea is between about 5 millimeters and about 200 millimeters.

The display information 103 provided by the display 143 may include a characteristic feature related to the wavelength of the display information 103. In some embodiments, the display information 103 provided by the display 143 includes information having a narrow spectral bandwidth. Exemplary displays that provide the display information 103 having a narrow spectral bandwidth include organic light emitting diode displays and electroluminescent displays.

The display 143 is not limited to providing the display information 103. In some embodiments, the display 143 is substantially occluded, partially occluded, or substantially transparent. For a partially occluded or substantially transparent display, the display 143 may transmit the non-display information 105 in addition to providing the display information 103. An organic light emitting diode display is an exemplary display capable of providing substantially transparent, partially occluded, and substantially occluded operation.

Fig. 1D shows a block diagram of an apparatus 151 including the apparatus 101 (shown in Fig. 1A), wherein at least one of the one or more filters 115 includes a non-display path notch filter 153 or a non-display path polarizing filter 155 and further including the display 143 to provide the display information 103 in accordance with some embodiments. The apparatus 101 (dashed lines) includes the substrate 107 including the display information optical path 109 to receive the display information 103 and including the non-display information optical path 111 to receive the non-display information 105. The display information optical path 109 includes the display information path optical power 113. The non-display information optical path 111 includes the one or more filters 115 and the non-display information path optical power 117. In some embodiments, the display information optical path includes a display path bandpass filter 157. In some embodiments, the display information optical path includes a display path polarizing filter 159.

The non-display path notch filter 153 is selected to substantially block the display information 103 in the non-display information optical path 111. In some embodiments, the non-display path notch filter 153 is selected to block at least about 90% of the energy included in the display information 103. Blocking less than about 90% of energy included in the display information 103 may result in blurring of the display information 103 and the non-display information 105. The non-display path notch filter 153 is not limited to a particular type of notch filter. In some embodiments, the non-display path notch filter 153 includes a thin film interference filter, such as a rugate filter. Notch filters, such as the non-display path notch filter 153, are formed by periodically varying the refractive index in each of a plurality of discrete thin film layers included in a contact lens. Microlithographic processes can be applied to each of the

plurality of discrete thin film layers to pattern the notch filters. The plurality of discrete thin film layers may be introduced into the contact lens during the molding of the lens.

In operation, the non-display path notch filter 153 is included in the non-display information optical path 111 to block narrow bandwidth electromagnetic radiation included in the display information 103. If the non-display information 105 includes broad spectral bandwidth electromagnetic radiation, the non-display path notch filter 153 has substantially no effect on the non-display information 105. The non-display information 105 passes through the non-display information optical path 111 substantially unchanged.

In some embodiments, the frequencies to be blocked by the non-display path notch filter 153 include the primary colors included in the spectrum of the display information 103. For example, for the display information 103 having primary colors red, green, and blue, the one or more filters 115 are selected to substantially block narrow spectrum red, green, and blue. The transmission curve to substantially block narrow spectrum red, green, and blue includes "notches" or a transmission coefficient of substantially zero at the one or more bands of frequencies to be blocked, narrow spectrum red, green, and blue. In some embodiments, the "notches" have a bandwidth that blocks a band of frequencies, such as, for example, a band of frequencies having a narrow spectrum of between about two and about thirty nanometers, centered on each of the primary colors, red, green, and blue.

The non-display path polarizing filter 155 is selected to substantially block the display information 103 in the non-display information optical path 111. The non-display path polarizing filter 155 is not limited to a particular type of polarizing filter. In some embodiments, the non-display path polarizing filter 155 includes a filter to substantially block right-handed circularly polarized radiation. In some embodiments, the non-display path polarizing filter 155 is selected to substantially block left-handed circularly polarized electromagnetic radiation. In some embodiments, the non-display path polarizing filter 155 is selected to substantially block linearly polarized electromagnetic radiation. Pixelated micro-wires and birefringent polymers are suitable for use in forming linear polarizers for use in forming polarizing filters, such as the non-display path polarizing filter 155. Circular polarizers are formed by adding a quarter wave-plate retarder in series with a linear polarizer.

In operation, the non-display path polarizing filter 155 is included in the non-display information optical path 111 to block polarized electromagnetic radiation included in the display information 103. For example, if the display information 103 includes left-handed circularly polarized electromagnetic radiation and the non-display information 105 includes right-handed circularly polarized electromagnetic radiation, the non-display path polarizing filter 155 is selected to substantially block the left-handed circularly polarized electromagnetic radiation

while having substantially no effect on the right-handed circularly polarized electromagnetic radiation of the non-display information 105. The non-display information 105 passes through the non-display information optical path 111 substantially unchanged.

The display path bandpass filter 157 is selected to substantially block the
5 non-display information 105 in the display information optical path 109. The display path bandpass filter 157 is not limited to a particular type of bandpass filter. In some embodiments, the display path bandpass filter 157 includes a thin film interference filter, such as a rugate filter. Bandpass filters, such as the display path bandpass filter 157, are formed by varying the refractive index in each of a plurality of thin films to selectively pass the desired wavelength
10 bands and including the plurality of discrete thin film layers in a contact lens. Microlithographic processes can be applied to the plurality of thin films to pattern the bandpass filters. The plurality of discrete thin film layers may be introduced into the contact lens during the molding of the lens.

In operation, the display path bandpass filter 157 included in the display information
15 optical path 109 is selected to substantially block broad spectral bandwidth electromagnetic radiation included in the non-display information 105. If the display information 103 includes narrow spectral bandwidth electromagnetic radiation substantially matched to the passband of the display path bandpass filter 157, the display path bandpass filter 157 has substantially no effect on the display information 103. The display information 103 passes through the display
20 information optical path 109 substantially unchanged.

The display path polarizing filter 159 is selected to substantially block the non-display information 105 in the display information optical path 109. The display path polarizing filter 159 is not limited to a particular type of polarizing filter. In some embodiments, the display path polarizing filter 159 includes a linearly polarized filter.

In operation, the display path polarizing filter 159 is included in the display information
25 optical path 109 to substantially block electromagnetic radiation included in the non-display information 105. If the display information 103 includes right-handed circularly polarized electromagnetic radiation and the display path polarizing filter 159 is selected to transmit right-handed circularly polarized electromagnetic radiation, the display path polarizing filter 159 has
30 substantially no effect on the display information 103. The display information 103 passes through the display information optical path 109 substantially unchanged.

In some embodiments, in operation the apparatus 151 processes a combination of spectral bandwidths and polarizations in the display information 103 and the non-display information 105. First, in some embodiments, the display information 103 includes display
35 electromagnetic radiation having a narrow spectral bandwidth and the non-display information

105 includes non-display electromagnetic radiation having a broad spectral bandwidth. Second, in some embodiments, the display information 103 includes display electromagnetic radiation having a display information polarization and the non-display information 105 includes non-display electromagnetic radiation having a non-display information polarization. Third, in some
5 embodiments, the display information 103 includes display electromagnetic radiation having a narrow spectral bandwidth and a display information polarization and the non-display information 105 includes non-display electromagnetic radiation having a broad spectral bandwidth. Fourth, in some embodiments, the display information 103 includes display information including display electromagnetic radiation having a narrow spectral bandwidth and
10 a display information polarization and the non-display information 105 including non-display electromagnetic radiation having a broad spectral bandwidth and a non-display information polarization.

Fig. 1E shows a block diagram of an apparatus 161 including the apparatus 101 (shown in Fig. 1A), wherein the one or more filters 115 includes the non-display path
15 polarizing filter 155 (shown in Fig. 1D) and further including the display 143 (shown in Fig. 1C) in accordance with some embodiments. The apparatus 101 includes the substrate 107 including the display information optical path 109 to receive the display information 103 and including the non-display information optical path 111 to receive the non-display information 105. The display information optical path 109 includes the display information path optical power 113.
20 The non-display information optical path 111 includes the one or more filters 115 and the non-display information path optical power 117. The display information 103 includes electromagnetic radiation having a display information polarization. The non-display information 105 includes non-display electromagnetic radiation having a non-display information polarization.

25 The non-display path polarizing filter 155 is selected to block the display information 103. In some embodiments, the display information 103 includes electromagnetic radiation having the display information polarization. To block the display information 103, the non-display path polarizing filter 155 is selected to block electromagnetic radiation having the display information polarization. In some embodiments, the non-display information 105
30 includes the non-display electromagnetic radiation having the non-display information polarization. The non-display path polarizing filter 155 is selected to pass the non-display electromagnetic radiation having the non-display information polarization.

Fig. 2A shows a block diagram of an apparatus 201 to receive and process the display information 103 and the non-display information 105 in accordance with some embodiments.
35 The apparatus 201 includes the substrate 107 including the display information optical path 109

to receive the display information 103 and including the non-display information optical path 111 to receive the non-display information 105. The display information optical path 109 includes the display information path optical power 113. The non-display information optical path 111 includes one or more controllable optical materials 203 and the non-display information path optical power 117.

The one or more controllable optical materials 203 include materials having one or more controllable optical properties. In some embodiments, the one or more controllable optical materials 203 include photochromic materials. The controllable optical properties, such as opacity, may be controlled by providing the photochromic material with an electromagnetic signal, such as an optical signal, for example, to increase or decrease the opacity of the photochromic material.

In some embodiments, the one or more controllable optical materials 203 include an electrochromic material. The one or more controllable optical properties, such as opacity, may be controlled by providing the electrochromic material with an electromagnetic signal, such as a radio frequency signal, for example, to increase or decrease the opacity of the electrochromic material.

In operation, the one or more controllable optical materials 203 included in the non-display information optical path 111 block or transmit information in the non-display information optical path 111. When at least one of the one or more controllable optical materials 203 is set to block information in the non-display information optical path 111, substantially only display information 103 in the display information optical path 109 passes through the substrate 107.

Neither the display information path optical power 113 nor the non-display information path optical power 117 is limited to a particular power. In some embodiments, the apparatus 201 includes a combination of optical powers. First, in some embodiments, the display information path optical power 113 includes substantially zero power and the non-display information path optical path power 117 includes substantially zero power. Second, in some embodiments, the display information path optical power 113 includes substantially zero power and the non-display information path optical power 117 includes a normal power. Third, in some embodiments, the display information path optical power 113 includes a close power and the non-display information path optical power 117 includes substantially zero power. Fourth, in some embodiments, the display information path optical power 113 includes a close power and the non-display information path optical power 117 includes normal power.

Fig. 2B shows a block diagram of the apparatus 201 (shown in Fig. 2A) coupled to the human visual system 131 in accordance with some embodiments. The apparatus 201 (dashed

lines) includes the substrate 107 including the display information optical path 109 to receive the display information 103 and including the non-display information optical path 111 to receive the non-display information 105. The display information optical path 109 includes the display information path optical power 113. The non-display information optical path 111 includes the one or more controllable optical materials 203 and the non-display information path optical power 117.

In some embodiments, the display information optical path 109 has an aperture 119. The aperture 119 may be sized to assist in focusing the display information 103. In some embodiments, the aperture 119 is sized to increase the depth of focus in the display information optical path 109. In some embodiments, the aperture 119 has a diameter of about one millimeter.

In operation, the display information optical path 109 and the non-display information optical path 111 assist the human visual system 131 in forming a focused image of the display information 103 at the retina 133 and a focused image of the non-display information 105 at the retina 133. The display information optical path 109 in cooperation with the human visual system 131, including the human lens 134, substantially focuses the display information 103 at the retina 133 to form a retinal display information image 135. The non-display information optical path 111 in cooperation with the human visual system 131, including the human lens 134, substantially focuses the non-display information 105 at the retina 133 to form a retinal non-display information image 137. At least one of the one or more controllable optical materials 203 in the non-display information optical path 111 substantially blocks the display information 103 from entering the human visual system 131 from the non-display information optical path 111.

Fig. 2C shows a block diagram of an apparatus 211 including the apparatus 201 (shown in Fig. 2A), and further including the display 143 (shown in Fig. 1C) to provide the display information 103 in accordance with some embodiments. The apparatus 201 (dashed lines) includes the substrate 107 including the display information optical path 109 to receive the display information 103 and including the non-display information optical path 111 to receive the non-display information 105. The display information optical path 109 includes the display information path optical power 113. The non-display information optical path 111 includes the one or more controllable optical materials 203 and the non-display information path optical power 117. In some embodiments, the display information 103 includes information provided by the display 143.

Fig. 2D shows a block diagram of an apparatus 221 including the apparatus 201 (shown in Fig. 2A), wherein at least one of the one or more controllable optical materials 203 includes a

photochromic material 223 or an electrochromic material 225 and further including the display 143 to provide the display information 103 and one or more optical material activation signals 227 in accordance with some embodiments. The apparatus 201 (dashed lines) includes the substrate 107 including the display information optical path 109 to receive the display
5 information 103 and including the non-display information optical path 111 to receive the non-display information 105. The display information optical path 109 includes the display information path optical power 113. The non-display information optical path 111 includes the one more controllable optical materials 203 and the non-display information path optical power 117. In some embodiments, the display information optical path 109 includes the display path
10 bandpass filter 157. In some embodiments, the display information optical path 109 includes the display path polarizing filter 159.

The one or more material activation signals 227 provide control information to the one or more controllable optical materials 203. In some embodiments, the one or more material activation signals 227 provide control information to the photochromic material 223. An optical
15 signal is an exemplary signal suitable for use in providing control information to the photochromic material 223. In some embodiments, the one or more material activation signals 227 provide control information to the electrochromic material 225. A radio frequency signal is an exemplary signal suitable for use in providing control information to the electrochromic material 225. In some embodiments, the one or more material activation signals 227 are
20 provided by the display 143.

In operation, one or more of the photochromic material 223 and the electrochromic material 225 are included in the non-display information optical path 111 to block or transmit information in the non-display information optical path 111. When at least one of the one or more of the photochromic material 223 and the electrochromic material 225 is set to block
25 information in the non-display information optical path 111, substantially only display information 103 in the display information optical path 109 passes through the substrate 107.

Fig. 3 shows an apparatus 301 including a substrate 303 including an optical path 305 having one or more zone plates 307 to receive the display information 103 and the non-display information 105 in accordance with some embodiments.

30 The substrate 303 is not limited to being formed from a particular material or combination of materials. Any materials suitable for use in forming optical components, such as lenses, may be used in forming the substrate 303. Exemplary materials suitable for use in forming the substrate 303 include gels, such as silicone hydrogels, glasses, plastics, and polymers, such as polymethyl methacrylate and polycarbonate. The substrate 303 is not limited to

a particular type of optical component. In some embodiments, the substrate 303 includes a lens, such as a contact lens, formed from one or more of the exemplary materials.

The formation of the one or more zone plates 307 is not limited to a particular process or set of processes. In some embodiments, each of the one or more zone plates 307 is formed by patterning an interference filter, such as a rugate filter, in concentric rings in one of the one or more zone plates 307. The patterning of a rugate filter is not limited to a particular type of patterning. In some embodiments, the patterning includes binary patterning. In some embodiments, the patterning includes sinusoidal patterning. The refractive index of the rugate filter may vary continuously and periodically.

The one or more zone plates 307, in some embodiments, include three zone plates stacked substantially one on top of the other in the optical path 305 included in the substrate 303. In some embodiments, a display that provides the display information 103 includes the primary colors red, green, and blue and the one or more zone plates 307 are selected to filter the primary colors. To filter the colors red, green, and blue, in some embodiments, one of the one or more zone plates 307 includes a rugate filter formed to filter the color red. A second of the one or more zone plates 307 includes a rugate filter formed to filter the color green. And a third of the one or more zone plates 307 includes a rugate filter formed to filter the color blue. The rugate filter formed to filter the color red includes rings that block red and rings that pass all other colors. The rugate filter formed to filter the color green includes rings that block green and rings that pass all other colors. And the rugate filter formed to filter the color blue includes rings that block blue and rings that pass all other colors.

In some embodiments, the display information 103 is substantially collimated by the one or more zone plates 307. To collimate the display information 103, the one or more zone plates 307 are formed to have a focal length of between about five and about two hundred millimeters.

In operation, the apparatus 301 processes the display information 103 and the non-display information 105 substantially simultaneously. The display information 103 is diffracted and substantially focused as the display information 103 passes through the optical path 305. The non-display information 105 passes through the optical path 305 substantially unchanged. The display information 103 and the non-display information 105 are focused to substantially the same focal point at substantially the same time. For a focal point located at a retina of a human visual system, the brain superimposes the two images.

The apparatus 301, in some embodiments, includes a display 309. In some embodiments, the display 309 provides the display information 103 including display electromagnetic radiation having at least one characteristic feature. The non-display information 105 includes non-display electromagnetic radiation lacking the at least one characteristic feature.

In some embodiments, the display 309 provides the display information 103 including display electromagnetic radiation having a narrow spectral bandwidth. The non-display information 105 includes non-display electromagnetic radiation having a broad spectral bandwidth. In some embodiments, the display 309 provides the display information 103 including display electromagnetic radiation having a display information polarization. The non-display information 105 includes non-display electromagnetic radiation having a non-display information polarization different from the display information polarization.

The optical path 305 is not limited to a particular optical power. In some embodiments, the optical path 305 provides substantially zero optical power 313 for the non-display information 103. In some embodiments, the optical path 305 provides a normal optical power 315 for the non-display information 105.

In some embodiments, the apparatus 301 includes a filter 317 substantially surrounding around the optical path 305. In some embodiments, when the apparatus 301 is used in combination with a human visual system, the filter 317 includes a substantially opaque filter to substantially block the display information 103 outside the optical path 305 from entering the human visual system. In some embodiments, when the apparatus 301 is used in combination with a human visual system, the filter 317 includes a non-display path polarizing filter to substantially block the display information 103 outside the optical path 305 from entering the human visual system. In some embodiments, when the apparatus 301 is used in combination with a human visual system, the filter 317 includes a notch filter to substantially block the display information 103 outside the optical path 305 from entering the human visual system.

Figs. 4A and 4B (diametrical section of contact lens 401 shown in 4A) show illustrations of a contact lens 401 including the display information optical path 109 and the non-display information optical path 111 in accordance with some embodiments. The display information optical path 109 forms a substantially cylindrical path through a central area of the contact lens 401. The diameter of the display information optical path 109 may be sized to increase the depth of focus and thereby assist in focusing light from a display, such as a head-mounted display, to a retina in a wearer's visual system. In some embodiments, the display information optical path 109 includes a focusing element 403, such as a lens, to assist the wearer's visual system in focusing light rays to the retina. In some embodiments, the display information optical path 109 includes a wavelength selective filter, a polarization selective filter, or a variable opacity filter including one or more controllable optical materials such as electrochromic or photochromic materials.

The non-display information optical path 111 forms a substantially annular ring surrounding the display information optical path 109. The non-display information optical path 111 may also include a non-display information path optical power to assist the wearer's visual system in focusing light rays from objects located at a greater distance from the wearer's visual system than the display. The non-display information path optical power assists the wearer's visual system by providing an appropriate power to correct for deficiencies in the wearer's visual system. For example, for a nearsighted wearer, the non-display information optical path 111 may include an optical power to correct for the wearer's nearsightedness and permit the nearsighted wearer to substantially clearly view objects more distant from the wearer's visual system than the display. In some embodiments, the non-display information optical path 111 includes a wavelength selective filter (including a wavelength selectivity different from the selectivity of the wavelength selective filter of the display information optical path 109), a polarization selective filter (including a polarization selectivity different from the polarization selectivity of the polarization selective filter of the display information optical path 109), or a variable opacity filter.

In operation, the contact lens 401 substantially conforms to the shape of a wearer's cornea. The display information optical path 109 receives and passes or transmits light rays from the display to the wearer. The non-display information optical path 111 receives and passes or transmits light rays from objects more distant from the wearer's visual system than the display.

Fig. 5 shows an illustration of the display 143 optically coupled by the contact lens 401 to the human visual system 131 to illustrate processing non-display information using wavelength filters in accordance with some embodiments. In some embodiments, the display 143 includes a display notch filter 501 and an organic light emitting diode display 503. In some embodiments, the contact lens 401 includes the display path bandpass filter 157, such as a narrow band bandpass filter, the focusing element 505 to provide display information path optical power, and the one or more filters 115, such as one or more notch filters. The human visual system 131 includes an iris 507, the human lens 134, and the retina 133.

In operation, the light rays 509 received from objects more distant from the contact lens 401 than the display 143 encounter the display 143, the contact lens 401, and the human visual system 131. At the display 143, the display notch filter 501 filters the light rays 509. The wavelengths of the light rays 509 that correspond to the wavelength notches of display notch filter 501 are substantially removed by the display notch filter 501, leaving light rays 511. The light rays 511 pass through the display 143 substantially unaltered. At the contact lens 401, the light rays 511 are substantially blocked by the display path bandpass filter 157 and substantially

passed by the one or more filters 115. At the human visual system 131, one or more of the light rays 511 pass through the iris 507 to form light rays 513. The human lens 134 focuses the light rays 513 to the retina 133.

Shadow 515 is created by the light rays blocked by the display path bandpass filter 157. The display path bandpass filter 157 slightly reduces the image intensity at the retina 133 when compared to an image formed at the retina 133 in the absence of the display path bandpass filter 157. Otherwise, the image at the retina 133 is substantially unaltered by the display path bandpass filter 157. The focusing element 505 has substantially no affect on the light rays 513 reaching the retina 133, as the light rays 511 received at the focusing element 505 are blocked by the display path bandpass filter 157.

In the absence of the display 143, a wearer of the contact lens 401 sees a normal, real world environment except that the light rays 511 now include the wavelengths substantially blocked by the display notch filter 501 when the display 143 is in use. At the contact lens 401, the wavelengths blocked at the display notch filter 501 when the display 143 is in use are passed by the display path bandpass filter 157 and defocused by the focusing element 505.

Fig. 6 shows an illustration of the display 143 optically coupled by the contact lens 401 to the human visual system 131 to illustrate processing display information using wavelength filters in accordance with some embodiments. The display 143 includes the display notch filter 501 and the organic light emitting diode display 503. The contact lens 401 includes the display path bandpass filter 157, such as a narrow bandwidth bandpass filter, the focusing element 505 to provide display information path optical power, and the one or more filters 115. The human visual system 131 includes the iris 507, the human lens 134, and the retina 133.

In operation, light rays 601 and 602 are provided by the organic light emitting diode display 503. The light rays 602 are blocked by the display notch filter 501. Thus, the light rays 602 are not visible to a viewer looking at a wearer of the contact lens 401. The light rays 601 are received at the contact lens 401 and the human visual system 131. The light rays 601 are blocked by the one or more filters 115, for example, a notch filter, but are passed as light rays 603 by the display path bandpass filter 157. The focusing element 505, such as a focusing lens, provides optical power to assist the human lens 134 to focus the light rays 603 to the retina 133. The light rays 603 are substantially unaffected by the iris 507.

In some embodiments, the display 143 is occluded or partially occluded. In some embodiments, material having an opacity is included in the display 143 to provide the occlusion or partial occlusion. When the material is included in the display 143 on the side of display 143 facing away from the contact lens 401, some or all of the non-display information or ambient light rays are blocked. In such embodiments, the display notch filter 501 is not required.

Fig. 7 shows an illustration of the display 143 optically coupled by the contact lens 401 to the human visual system 131 to illustrate processing to combine non-display information and display information using wavelength filters in accordance with some embodiments. The display 143 includes the display notch filter 501 and the organic light emitting diode display 503. The contact lens 401 includes the display path bandpass filter 157, the focusing element 505 to provide display information path optical power, and the one or more filters 115. The human visual system 131 includes the iris 507, the human lens 134, and the retina 133.

In operation, the light rays 509 received from objects more distant from the contact lens 401 than the display 143 are processed as described above in the description of Fig. 5 to provide light rays 511 and 513. The light rays 601 and 602 provided by the display 143 are processed as described above in the description of Fig. 6 to provide light rays 603. The light rays 603 come to a focus at substantially the same spot on the retina 133 as the light rays 513. The wearer's brain combines the retinal images provide by the light rays 603 and the light rays 509 to form a superimposed image.

Fig. 8 shows an illustration of the display 143 optically coupled by the contact lens 401 to the human visual system 131 to illustrate processing non-display information using polarizing filters in accordance with some embodiments. The display 143 includes the organic light emitting diode display 503, a display polarizing filter 801, and display shutters 803 and 805. The contact lens 401 includes a display path filter 807, such as a display path bandpass filter or a display path polarizing filter, the focusing element 505 to provide display information path optical power, and the non-display path polarizing filter 155. The human visual system 131 includes the iris 507, the human lens 134, and the retina 133.

In operation, the light rays 809 are polarized by the display polarizing filter 801 to form light rays 811. The shutters 803 and 805 are switched to the same polarization as the display polarizing filter 801. Thus, the light rays 811 pass through the shutters 803 and 805 substantially unaltered. The organic light emitting diode display 503 is set to an "off" state and is therefore substantially translucent to the light rays 811. Thus, the light rays 811 also pass through the organic light emitting diode display 503 substantially unaltered. The light rays 811 are substantially blocked by the display path filter 807. In some embodiments, the display path filter 807 includes the display path bandpass filter 157 (shown in Fig. 1D). In some embodiments, the display path filter 807 includes the display path polarizing filter 159 (shown in Fig. 1D) having a polarization different from the polarization of the shutters 803 and 805. The non-display path polarizing filter 155 has the same polarization as the shutters 803 and 805. Thus, the light rays 811 pass through the non-display path polarizing filter 155 substantially

unaltered. At the human visual system 131, the iris 507 limits the light rays passing through the iris 507 to light rays 813. The human lens 134 focuses the light rays 813 at the retina 133.

Shadow 815 is created by the light rays blocked by the display path filter 807. The display path filter 807 slightly reduces the image intensity at the retina 133 when compared to an image formed at the retina 133 in the absence of the display path filter 807. Otherwise, the image at the retina 133 is substantially unaltered by the display path filter 807. The focusing element 505 has substantially no affect on the light rays 811 reaching the retina 133, as the light rays 811 passing through the focusing element 505 are substantially blocked by the display path filter 807.

In the absence of the display 143, a wearer of the contact lens 401 sees a normal, real world environment except the light rays 811 are polarized. For the display path filter 807 including either a polarizing filter or a bandpass filter, the light rays passing through the display path filter 807 are defocused by the focusing element 505 before reaching retina 133.

Fig. 9 shows an illustration of the display 143 optically coupled by the contact lens 401 to the human visual system 131 to illustrate processing display information using polarizing filters in accordance with some embodiments. The display 143 includes the display polarizing filter 801, the display shutter 803, the organic light emitting diode display 503, and the display shutter 805. The contact lens 401 includes the non-display path polarizing filter 155, the display path filter 807, such as a display path bandpass filter or a display path polarizing filter, and the focusing element 505 to provide display information path optical power. The human visual system 131 includes the iris 507, the human lens 134, and the retina 133.

In operation, the display polarizing filter 801 polarizes the light rays 809 to form light rays 811. The shutter 803 is switched to a polarization to substantially block the light rays 811. The organic light emitting diode display 503 is set to an "on" state. The organic light emitting diode display 503 provides the light rays 601 and 602. The shutter 803 polarizes the light rays 602 to form light rays 901. The display polarizing filter 801 is set to a polarization to substantially block the light rays 901. Thus, the light rays 901 are not visible to a viewer looking at a wearer of the display 143. The shutter 805 polarizes the light rays 601 to form the light rays 903. The non-display path polarizing filter 155 is set to a polarization to substantially block the light rays 903. For the display path filter 807 set to substantially the same polarization as the shutter 805, the display path filter 807 passes the light rays 903 substantially unaltered. The focusing element 505, such as a focusing lens, provides optical power to assist the human lens 134 to focus the light rays 905 to the retina 133. Thus, the focusing element 505 may provide an optical power to assist the human lens 134 in focusing the light rays 903 at the retina 133. The human lens 134 in combination with the focusing element 505 processes the light rays

903 to form light rays 905. The iris 507 has substantially no effect on the light rays 905 substantially focused at the retina 133.

If the display 143 is occluded or partially occluded, the display polarization filter 801 is not required. Instead, in some embodiments, a material having an opacity is included on the side of the display 143 facing away from the contact lens 401 to block some or all of the light rays 509 including the non-display information.

In some embodiments, a quarter wave-plate is included in the shutter 805 to convert the light rays 601 having a linear polarization to a circular polarization. To support the processing of circularly polarized radiation, the non-display path polarizing filter 155 includes a filter to provide transmission of right-handed circularly polarized radiation. Also, to support the processing of circularly polarized radiation, the display path filter 807 includes a filter to provide transmission of left-handed circularly polarized radiation. In operation, to process the non-display information, the shutter 805 including the quarter wave-plate is set to pass right-handed circularly polarized radiation. In operation, to process the display information the shutter 805 including the quarter wave plate is set to pass left-handed circularly polarized radiation. In some embodiments, the display path filter 807 includes a display path bandpass filter.

A filter providing transmission of circularly polarized radiation, unlike a filter providing for transmission of linearly polarized radiation, does not require rotational alignment of the contact lens 401 with the human visual system 131. However, the non-display path polarizing filter 155 is not limited to a filter for processing circularly polarized radiation. In some embodiments, the non-display path polarizing filter 155 includes a filter to provide transmission of linearly polarized radiation.

Referring to Fig. 8 and Fig., 9, in operation, in some embodiments, the shutters 803 and 805 are switched between one polarization state and another polarization state in synchronization with the setting of the organic light emitting diode display 503 to an "on" state and an "off" state. For example, when the organic light emitting diode display 503 is set to an "on" state, the shutters 803 and 805 are switched to the state as described for Fig. 9 to process the display information provided by the light rays 601 and 602 from the organic light emitting diode display 503. And, for example, when the organic light emitting diode display 503 is set to an "off" state, the shutters 803 and 805 are switched to the state as described for Fig. 8 to process non-display information provided by the light rays 809. The switching rate is set to a frequency that allows the brain of a wearer of the contact lens 401 to substantially form a single image from the superposition of the images of the display information and the non-display information.

Polarizing shutters, such as the shutters 803 and 805, can utilize liquid crystal display panels that re-orient their liquid crystals in response to an applied electric field. When the crystals are oriented in one direction they pass electromagnetic radiation having a particular polarization. Changing the electric field to orient the crystals in a second direction causes electromagnetic radiation having a second polarization to be passed.

Figs. 10A and 10B (diametrical section of illustration shown in 10A) show illustrations of a contact lens 1001 including one or more zone plate filters 1003 in accordance with some embodiments. In some embodiments, the one or more zone plate filters 1003 are formed by patterning a rugate filter in concentric rings of a diffraction zone plate. A diffraction zone plate focuses light using diffraction to cause constructive interference at a focal point to create an image. A rugate filter includes optical interference films of varying thickness. The refractive index of the optical interference films varies as a function of the film's optical thickness. The use of a rugate filter in forming a zone plate results in a zone plate that operates on a particular set of wavelengths, for example, a narrow band of wavelengths. In some embodiments, the patterning of the zone plate is binary. Binary patterning includes substantially opaque and transparent rings of substantially equal areas. In some embodiments, the patterning is sinusoid. Sinusoid patterning includes rings having substantially gradual variations in opacity. In some embodiments, the contact lens 1001 includes a notch filter 1005 forming substantially an annular ring around the one or more zone plate filters 1003.

Fig. 11 shows an illustration of the display 143 optically coupled by the contact lens 1001 to the human visual system 131 to illustrate processing display information and non-display information using the one or more zone plate filters 1003 in accordance with some embodiments. The display 143 includes the display notch filter 501 and the organic light emitting diode display 503. The contact lens 1001 includes the one or more zone plate filters 1003. In some embodiments, the contact lens 1001 includes the notch filter 1005. The human visual system 131 includes the iris 507, the human lens 134, and the retina 133.

In operation, the light rays 509 providing non-display information received from objects more distant from the contact lens 1001 than the display 143 encounter the display 143, the contact lens 1001, and the human visual system 131. At the display 143, the display notch filter 501 filters the light rays 509. The wavelengths of the light rays 509 that correspond to the wavelength notches of the display notch filter 501 are substantially removed by the display notch filter 501, leaving the light rays 511. The light rays 511 pass through the display 143 substantially unaltered. At the contact lens 1001, the light rays 511 pass through the one or more zone plate filters 1003 and the notch filter 1005 substantially unaltered. At the human visual system 131, the iris 507 may block one or more of the light rays 511, leaving light rays

1007. The human lens 134 focuses the light rays 1007 including the non-display information at the retina 133.

In operation, the organic light emitting diode display 503 provides the light rays 601 and 602. The light rays 602 are directed away from the contact lens 1001 and are substantially
5 blocked by the display notch filter 501. Thus, the light rays 602 are not visible to a viewer looking at a wearer of the display 143. The light rays 601 are directed toward the contact lens 1001 including the notch filter 1005 and the one or more zone plate filters 1003. At the notch filter 1005, the light rays 601 are substantially blocked. At the one or more zone plate filters 1003, the light rays 601 are diffracted to form the light rays 1009. The human lens 134 focuses
10 the light rays 1009 including the display information at the retina 133.

In operation, the light rays 509 received from objects more distant from the contact lens 1001 than the display 143 are processed as described above to provide the light rays 1007 including the non-display information to the retina 133. The light rays 601 provided by the display 143 are processed as described above to provide the light rays 1009 including the display
15 information to the retina 133. The light rays 1007 and the light rays 1009 are focused at substantially the same spot at the retina 133 at substantially the same time. Thus, the brain of the wearer of the contact lens 1001 combines the retinal image provided by the light rays 1007 including the non-display information and the retinal image provided by the light rays 1009 including the display information to form a superimposed image including the display
20 information and the non-display information.

In the absence of the display 143, a wearer of the contact lens 1001 sees a normal, real world environment except the light rays 511 now include the wavelengths substantially blocked by the display notch filter 501. At the contact lens 1001, the wavelengths blocked at the display notch filter 501 when the display 143 is present are diffracted by the one or more zone plate
25 filters 1003 and defocused by the human lens 134.

If the display 143 is occluded or partially occluded, the display notch filter 501 is not required. Instead, in some embodiments, a material having an opacity is included on the side of the display 143 facing away from the contact lens 1001 to block some or all of the light rays 509 including the non-display information.

30 Fig. 12 shows an illustration of an apparatus 1201 including a substrate 1203, a substantially transparent pixel unit 1205, and an organic light emitting diode unit 1207 in accordance with some embodiments. The substrate 1203 includes a pattern 1209 of pixel sites including a first pattern of one or more first pixel sites 1211 and a second pattern of one or more second pixel sites 1213. The substantially transparent pixel unit 1205 is located at substantially
35 each of the one or more first pixel sites 1211. The organic light emitting diode pixel unit 1207

including a filter 1215 is located at substantially each of the one or more second pixel sites 1213. The filter 1215 is located on the substrate 1203 to enable filtering of the electromagnetic radiation emitted by the organic light emitting diode unit before the electromagnetic radiation reaches a viewer. To filter the electromagnetic radiation, such as visible light, emitted by the organic light emitting diode pixel unit 1207, the area of the filter 1215 is substantially equal to or greater than the area of the organic light emitting diode pixel unit 1207. In some embodiments, the filter 1215 is a narrow band filter. In some embodiments, the filter 1215 is a polarizing filter. The pattern 1209 of pixel sites is not limited to a particular pattern. In some embodiments, the pattern 1209 of pixel sites includes a checkerboard pattern including the first pattern of the one or more first pixel sites 1211 alternating with the second pattern of the one or more second pixel sites 1213. The sites are not limited to a particular shape and the shapes shown are only for schematic illustration.

Fig. 13 shows a flow diagram of a method 1301 including enabling and disabling transmission of display information and transmission of non-display information in accordance with some embodiments. In some embodiments, the method 1301 enables transmission of display information from a display and switches one or more shutters to a first polarization to polarize the display information (block 1303), and disables transmission of the display information from the display and switches the one or more shutters to a second polarization different from the first polarization to enable transmission of the non-display information through the one or more shutters (block 1305). In some embodiments, the method 1301 includes receiving the display information and the non-display information at a contact lens. In some embodiments, the method 1301 includes substantially blocking the display information at a non-display information optical path included in the contact lens and substantially transmitting the display information at a display information optical path included in the contact lens.

Fig. 14 shows a flow diagram of a method 1401 including polarizing display and non-display information and illuminating a contact lens with the polarized display and non-display information in accordance with some embodiments. In some embodiments, the method 1401 polarizes non-display information to form polarized non-display information and polarizes display information to form polarized display information (block 1403), illuminates a contact lens with the polarized non-display information while not illuminating the contact lens with the polarized display information (block 1405), and illuminates the contact lens with the polarized display information while not illuminating the contact lens with the polarized non-display information (block 1407). In some embodiments, the method 1401 includes substantially blocking the polarized display information at the non-display information path at the contact lens.

While apparatus and methods have been described in terms of several embodiments, those of ordinary skill in the art will recognize that the apparatus and methods are not limited to the embodiments described, but can be practiced with modification and alteration within the spirit and scope of the appended claims. The description is thus to be regarded as illustrative
5 instead of limiting.

What is claimed is:

1. A apparatus comprising:
a substrate including a display information optical path to receive display information
5 and a non-display information optical path to receive non-display information, the display
information optical path including a display information path optical power, and the non-
display information optical path including one or more filters and a non-display information path
optical power, the display information optical path when coupled to a human visual system to
substantially focus the display information to a retina in the human visual system and the non-
10 display information optical path when coupled to the human visual system to substantially focus
the non-display information to the retina in the human visual system and to substantially block
the display information from entering the human visual system from the non-display information
optical path.
- 15 2. The apparatus of claim 1, wherein the display information path optical power
includes substantially zero power and the non-display information path optical path power
includes substantially zero power.
- 20 3. The apparatus of claim 1, wherein the display information path optical power
includes substantially zero power and the non-display information path optical power includes a
normal power.
- 25 4. The apparatus of claim 1, wherein the display information path optical power
includes a close power and the non-display information path optical power includes substantially
zero power.
- 30 5. The apparatus of claim 1, wherein the display information path optical power
includes a close power and the non-display information path optical power includes a normal
power.
- 35 6. The apparatus of claim 1, wherein at least one of the one or more filters includes
a non-display path notch filter.
7. The apparatus of claim 6, further comprising a display to provide the display
information including display electromagnetic radiation having a narrow spectral bandwidth, the

non-display information including non-display electromagnetic radiation having a broad spectral bandwidth.

5 8. The apparatus of claim 6, wherein the display information optical path includes a display path bandpass filter.

10 9. The apparatus of claim 8, further comprising a display to provide the display information including display electromagnetic radiation having a narrow spectral bandwidth, the non-display information including non-display electromagnetic radiation having a broad spectral bandwidth.

10. The apparatus of claim 6, wherein the display information optical path includes a display path polarizing filter.

15 11. The apparatus of claim 10, further comprising a display to provide the display information including display electromagnetic radiation having a narrow spectral bandwidth and a display information polarization, the non-display information including non-display electromagnetic radiation having a broad spectral bandwidth.

20 12. The apparatus of claim 1, wherein at least one of the one or more filters includes a non-display path polarizing filter.

25 13. The apparatus of claim 12, further comprising a display to provide the display information including display electromagnetic radiation having a display information polarization, the non-display information including non-display electromagnetic radiation having a non-display information polarization.

30 14. The apparatus of claim 12, wherein the display information optical path includes a display path bandpass filter.

35 15. The apparatus of claim 14, further comprising a display to provide the display information including display electromagnetic radiation having a narrow spectral bandwidth and a display information polarization, the non-display information including non-display electromagnetic radiation having a broad spectral bandwidth and a non-display information polarization.

16. The apparatus of claim 12, wherein the display information optical path includes a display path polarizing filter.

5 17. The apparatus of claim 16, further comprising a display to provide the display information including display electromagnetic radiation having a display information polarization, the non-display information including non-display electromagnetic radiation having a non-display information polarization.

10 18. The apparatus of claim 1, further comprising a display to provide the display information including display electromagnetic radiation having at least one characteristic feature, the non-display information including non-display electromagnetic radiation lacking the at least one characteristic feature.

15 19. A apparatus comprising:

a substrate including a display information optical path to receive display information and a non-display information optical path to receive non-display information, the display information optical path including a display information path optical power, and the non-display information optical path including one or more filters including a non-display path polarizing filter and a non-display information path optical power, the display information optical path when coupled to a human visual system to substantially focus the display information to a retina in the human visual system and the non-display information optical path when coupled to the human visual system to substantially focus the non-display information to the retina in the human visual system and to substantially block the display information from entering the human visual system from the non-display information optical path; and

20 a display to provide the display information including display electromagnetic radiation having a display information polarization, the non-display information including non-display electromagnetic radiation having a non-display information polarization.

30 20. A apparatus comprising:

a substrate including a display information optical path to receive display information and a non-display information optical path to receive non-display information, the display information optical path including a display information path optical power, and the non-display information optical path including one or more controllable optical materials and a non-display information path optical power, the display information optical path when coupled to a human

visual system to substantially focus the display information to a retina in the human visual system and the non-display information optical path when coupled to the human visual system to substantially focus the non-display information to the retina in the human visual system and to substantially block the display information from entering the human visual system from the non-
5 display information optical path.

21. The apparatus of claim 20, wherein the display information path optical power includes substantially zero power and the non-display information path optical power includes substantially zero power.

10

22. The apparatus of claim 20, wherein the display information path optical power includes substantially zero power and the non-display information path optical power includes a normal power.

15

23. The apparatus of claim 20, wherein the display information path optical power includes a close power and the non-display information path optical power includes substantially zero power.

20

24. The apparatus of claim 20, wherein the display information path optical power includes a close power and the non-display information path optical power includes a normal power.

25

25. The apparatus of claim 20, wherein at least one of the one or more controllable optical materials includes a photochromic material.

30

26. The apparatus of claim 25, further comprising a display to provide one or more optical material activation signals and to provide the display information including display electromagnetic radiation having at least one characteristic feature, the non-display information including non-display electromagnetic radiation lacking the at least one characteristic feature.

27. The apparatus of claim 25, wherein the display information optical path includes a display path bandpass filter.

28. The apparatus of claim 27, further comprising a display to provide one or more optical material activation signals and to provide the display information including display electromagnetic radiation having a narrow spectral bandwidth, the non-display information including non-display electromagnetic radiation having a broad spectral bandwidth.

5

29. The apparatus of claim 25, wherein the display information optical path includes a display path polarizing filter.

30. The apparatus of claim 29, further comprising a display to provide one or more optical material activation signals and to provide the display information including display electromagnetic radiation having a display information polarization, the non-display information including non-display electromagnetic radiation having a non-display information polarization.

31. The apparatus of claim 20, wherein at least one of the one or more controllable optical materials includes an electrochromic material.

15

32. The apparatus of claim 31, further comprising a display to provide one or more optical material activation signals and to provide the display information including display electromagnetic radiation having at least one characteristic feature, the non-display information including non-display electromagnetic radiation lacking the at least one characteristic feature.

20

33. The apparatus of claim 31, wherein the display information optical path includes a display path bandpass filter.

34. The apparatus of claim 33, further comprising a display to provide one or more optical material activation signals and to provide the display information including display electromagnetic radiation having a narrow spectral bandwidth, the non-display information including non-display electromagnetic radiation having a broad spectral bandwidth.

25

35. The apparatus of claim 31, wherein the display information optical path includes a display path polarizing filter.

30

36. The apparatus of claim 35, further comprising a display to provide one or more optical material activation signals and to provide the display information including display

electromagnetic radiation having a display information polarization, the non-display information including non-display electromagnetic radiation having a non-display information polarization.

5 37. The apparatus of claim 20, further comprising a display to provide the display information including display electromagnetic radiation having at least one characteristic feature, the non-display information including non-display electromagnetic radiation lacking the at least one characteristic feature.

10 38. A apparatus comprising:
a substrate including an optical path having one or more zone plates to receive display information and non-display information, the optical path when coupled to a human visual system to substantially focus the display information to a retina in the human visual system and to substantially focus the non-display information to the retina in the human visual system.

15 39. The apparatus of claim 38, wherein the optical path provides substantially zero optical power for the non-display information.

20 40. The apparatus of claim 38, wherein the optical path provides a normal optical power for the non-display information.

41. The apparatus of claim 38, further comprising a non-display path notch filter to substantially block display information outside the optical path including the one or more zone plates from entering the human visual system.

25 42. The apparatus of claim 41, further comprising a display to provide the display information including display electromagnetic radiation having a narrow spectral bandwidth, the non-display information including non-display electromagnetic radiation having a broad spectral bandwidth.

30 43. The apparatus of claim 38, further comprising a non-display path polarizing filter to substantially block display information outside the optical path including the one or more zone plates from entering the human visual system.

35 44. The apparatus of claim 43, further comprising a display to provide the display information including display electromagnetic radiation having a display information

polarization, the non-display information including non-display electromagnetic radiation having a non-display information polarization.

5 45. The apparatus of claim 38, further comprising a substantially opaque filter to substantially block display information outside the optical path including the one or more zone plates from entering the human visual system.

10 46. The apparatus of claim 45, further comprising a display to provide the display information including display electromagnetic radiation having at least one characteristic feature, the non-display information including non-display electromagnetic radiation lacking the at least one characteristic feature.

15 47. The apparatus of claim 38, further comprising a display to provide the display information including display electromagnetic radiation having at least one characteristic feature, the non-display information including non-display electromagnetic radiation lacking the at least one characteristic feature.

20 48. An apparatus comprising:
one or more shutters to polarize display information and non-display information;
an organic light emitting diode display located adjacent to the one or more shutters, the organic light emitting diode display to provide the display information and to transmit non-display information; and
a polarizing filter located adjacent to the organic light emitting diode display, the polarizing filter to polarize the non-display information.

25 49. The apparatus of claim 48, wherein the one or more shutters includes a first shutter to transmit the display information and a second shutter to block the display information.

30 50. The apparatus of claim 48, further comprising:
a contact lens optically coupled to the organic light emitting diode display including a display path to receive the display information and a non-display path to receive the non-display information, the contact lens including a polarizing filter to block the display information and pass the non-display information.

51. An apparatus comprising:

a substrate including a pattern of pixel sites for the substrate, the pattern including a first pattern of one or more first pixel sites and a second pattern of one or more second pixel sites;

5 a substantially transparent pixel unit located at substantially each of the one or more first pixel sites; and

an organic light emitting diode pixel unit including a filter located at substantially each of the one or more second pixel sites.

52. The apparatus of claim 51, wherein the pattern includes a checkerboard pattern
10 including the first pattern of the one or more first pixel sites alternating with the second pattern of the one or more second pixel sites.

53. A method comprising:

15 enabling transmission of display information from a display and switching one or more shutters to a first polarization to polarize the display information; and

disabling transmission of the display information from the display and switching the one or more shutters to a second polarization different from the first polarization to enable transmission of the non-display information through the one or more shutters.

20 54. The method of claim 53, further comprising:

receiving the display information and the non-display information at a contact lens.

55. The method of claim 54, further comprising:

25 substantially blocking the display information at a non-display information optical path included in the contact lens and substantially transmitting the display information at a display information optical path included in the contact lens.

56. A method comprising:

30 polarizing non-display information to form polarized non-display information and polarizing display information to form polarized display information;

illuminating a contact lens with the polarized non-display information while not illuminating the contact lens with the polarized display information; and

illuminating the contact lens with the polarized display information while not illuminating the contact lens with the polarized non-display information.

35

57. The method of claim 56, further comprising:
substantially blocking the polarized display information at the non-display information path at the contact lens.

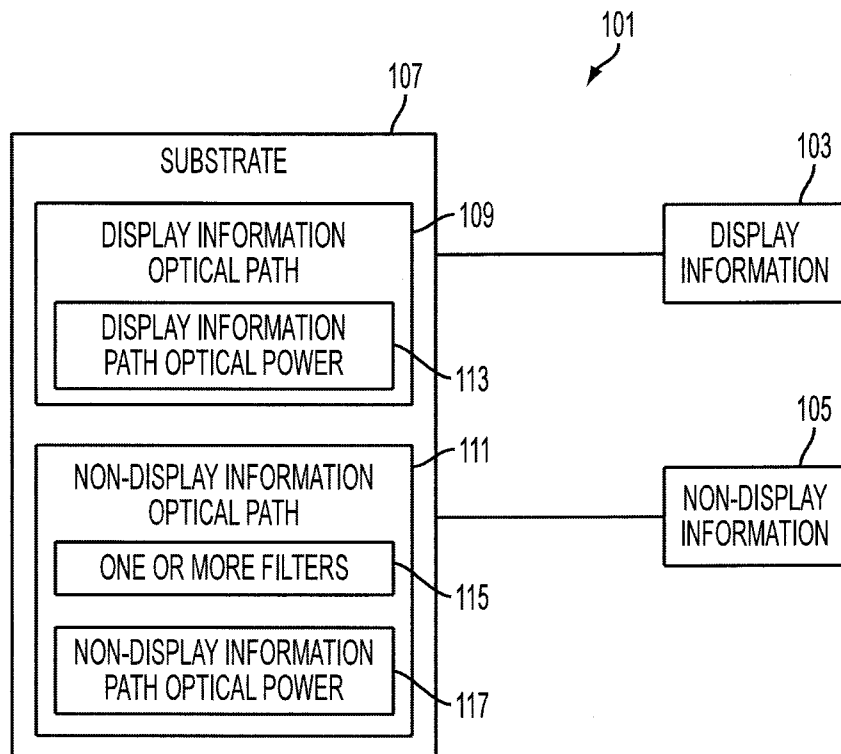

FIG. 1A

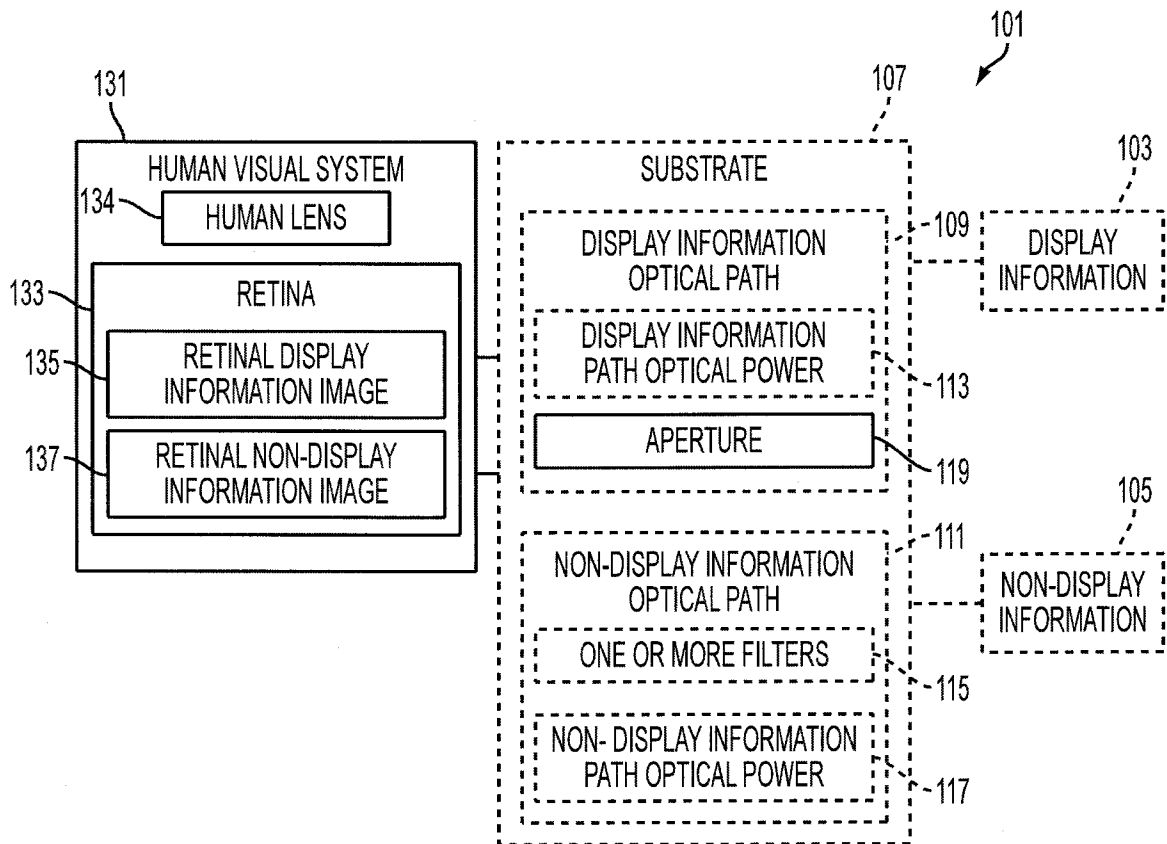

FIG. 1B

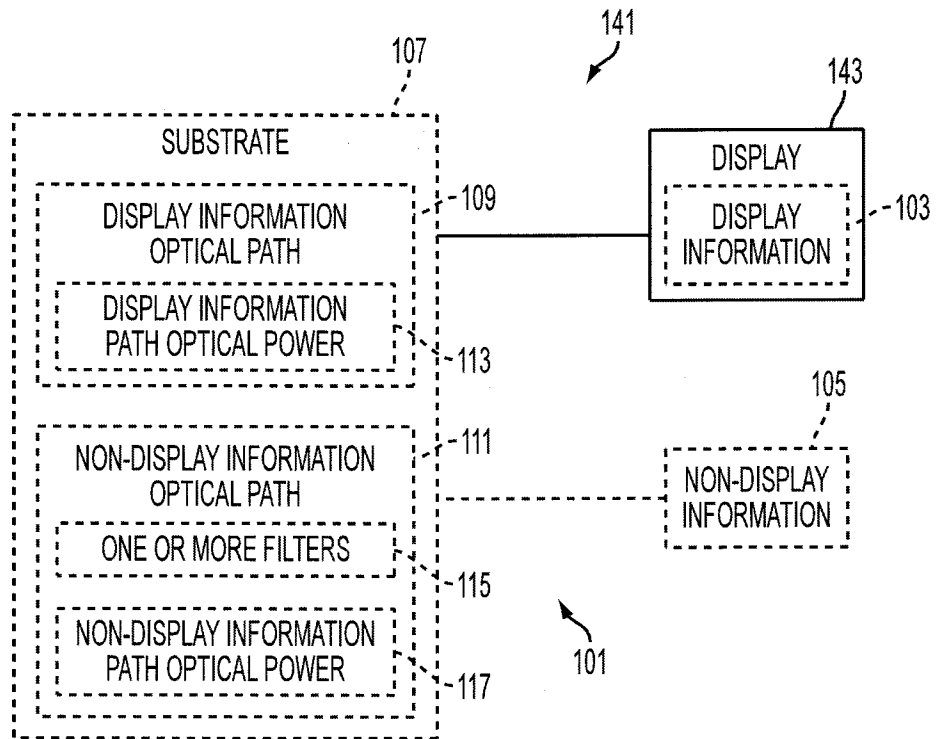

FIG. 1C

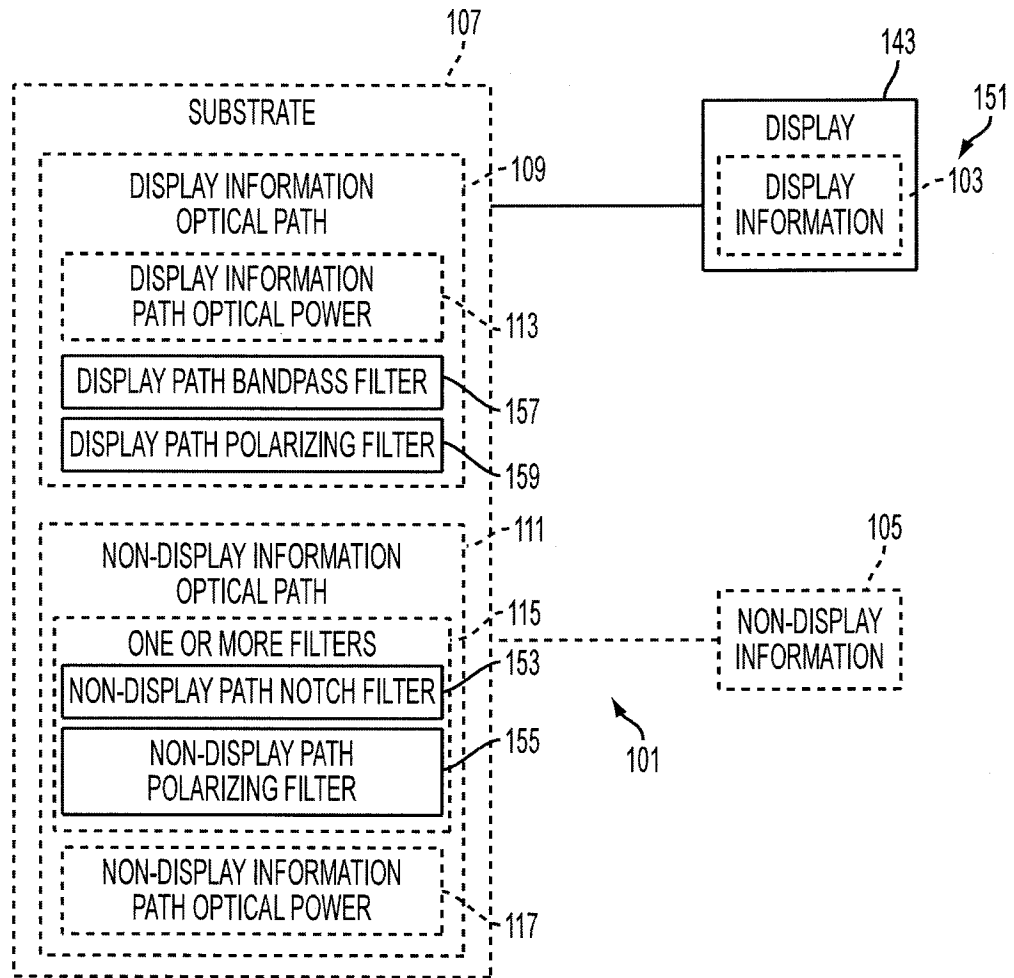

FIG. 1D

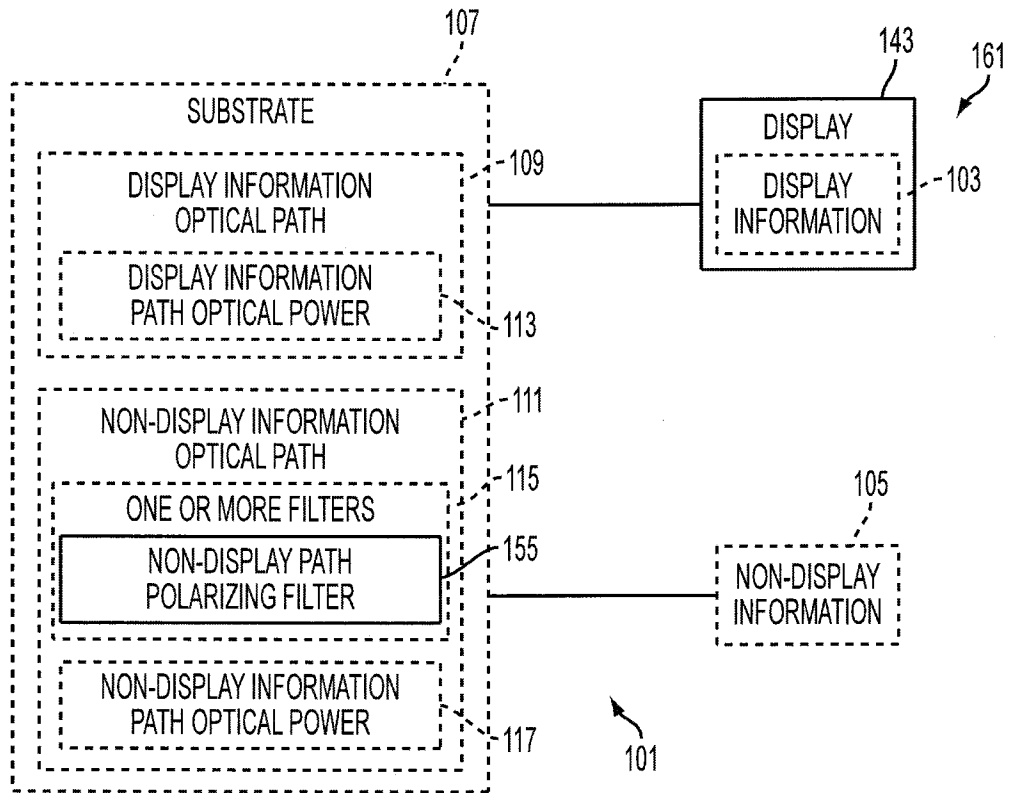

FIG. 1E

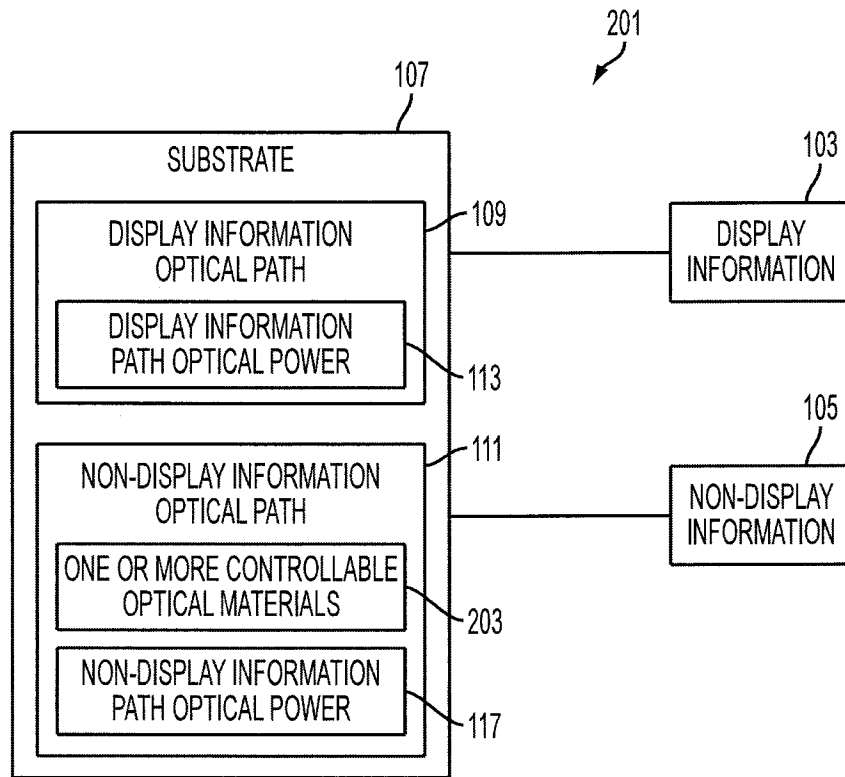

FIG. 2A

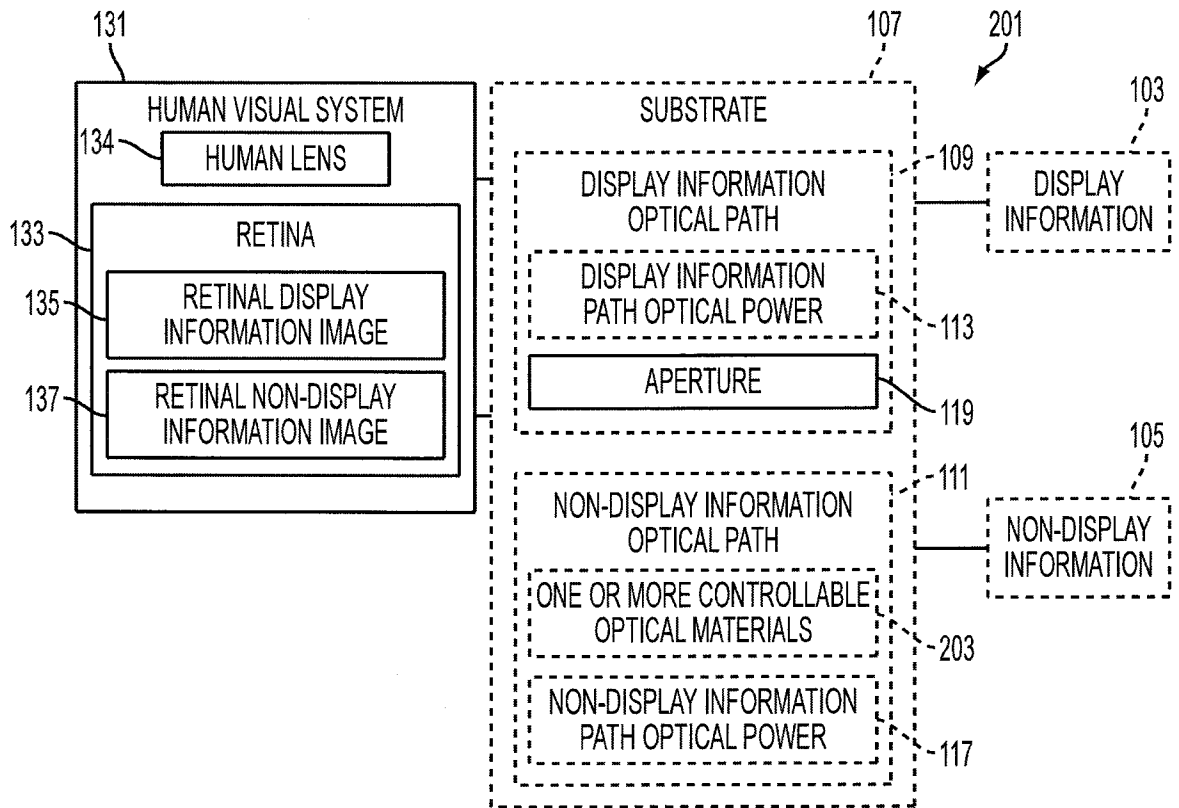

FIG. 2B

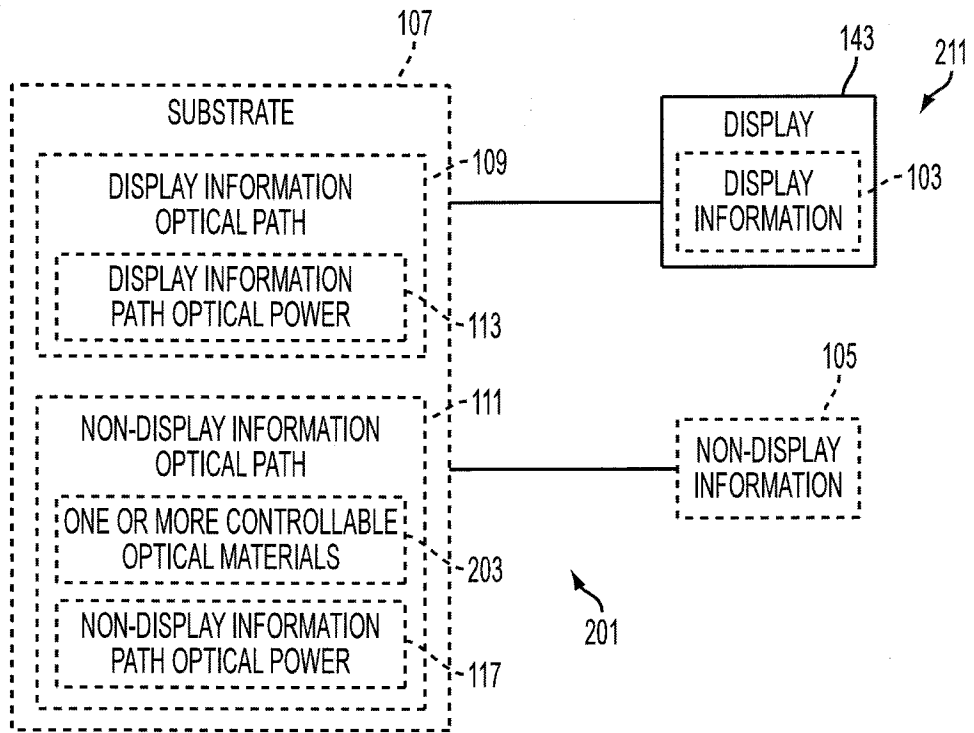

FIG. 2C

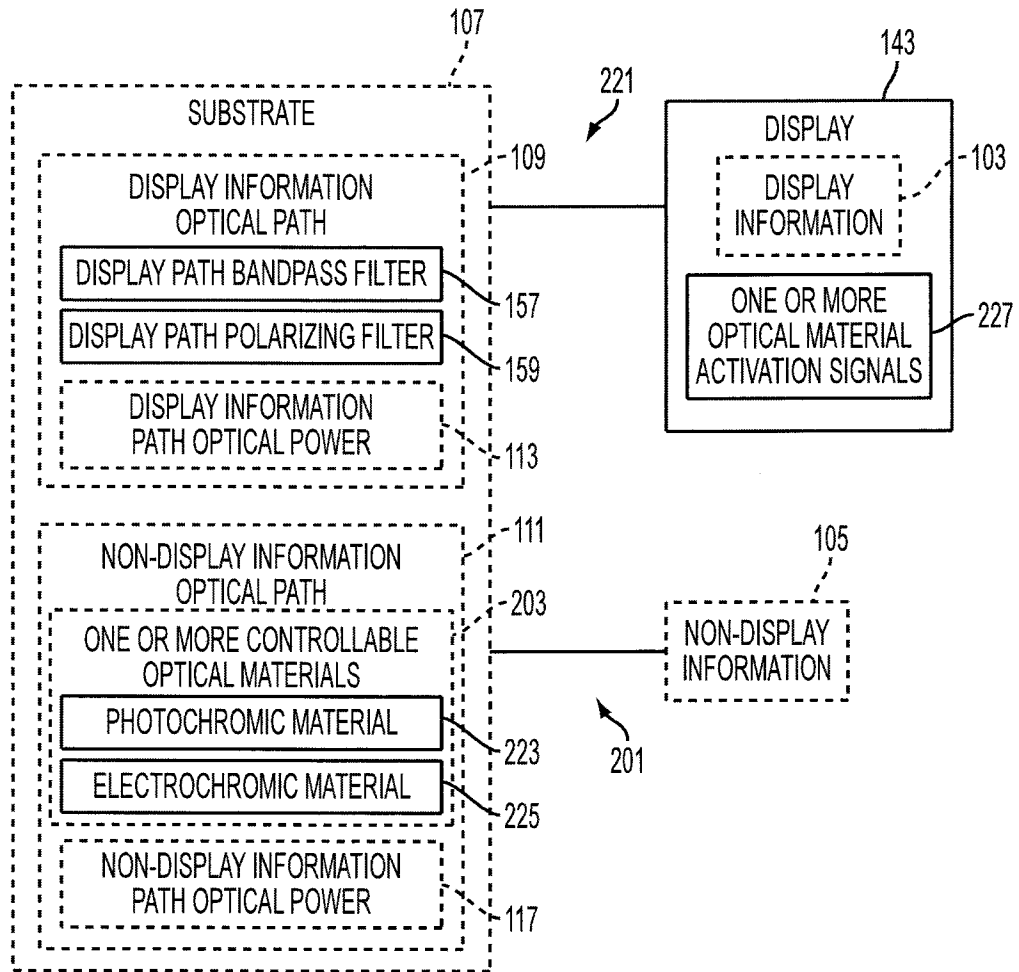

FIG. 2D

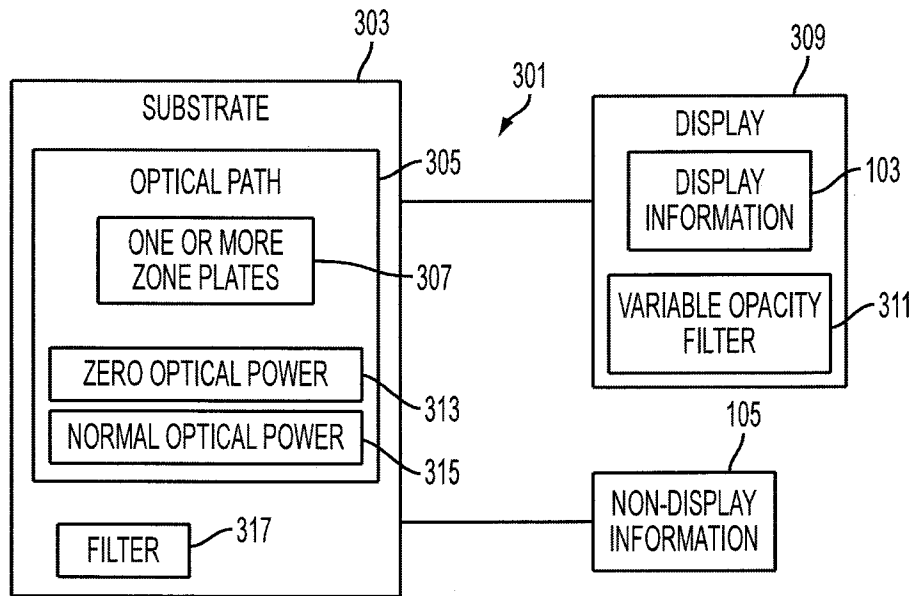

FIG. 3

11/18

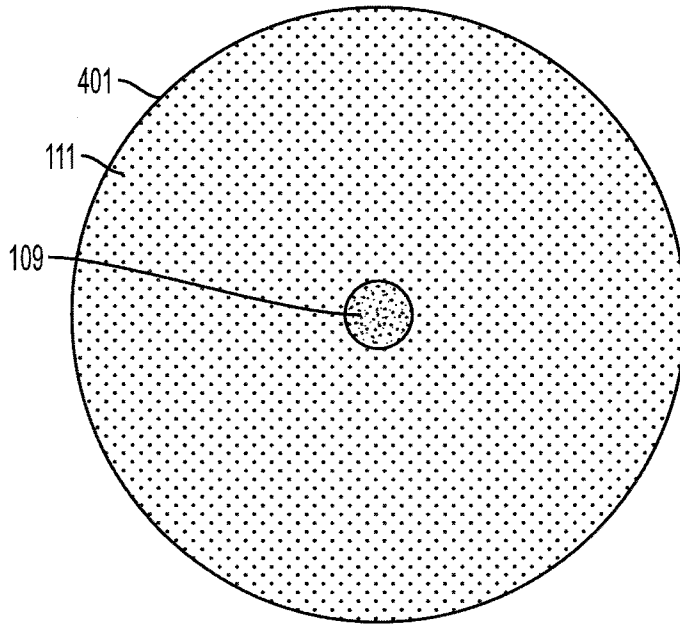

FIG. 4A

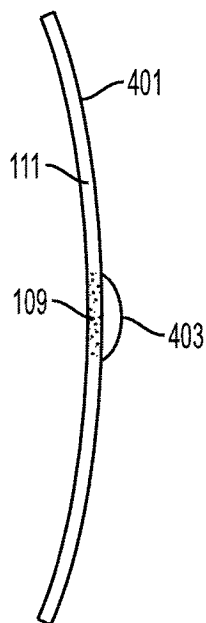

FIG. 4B

12/18

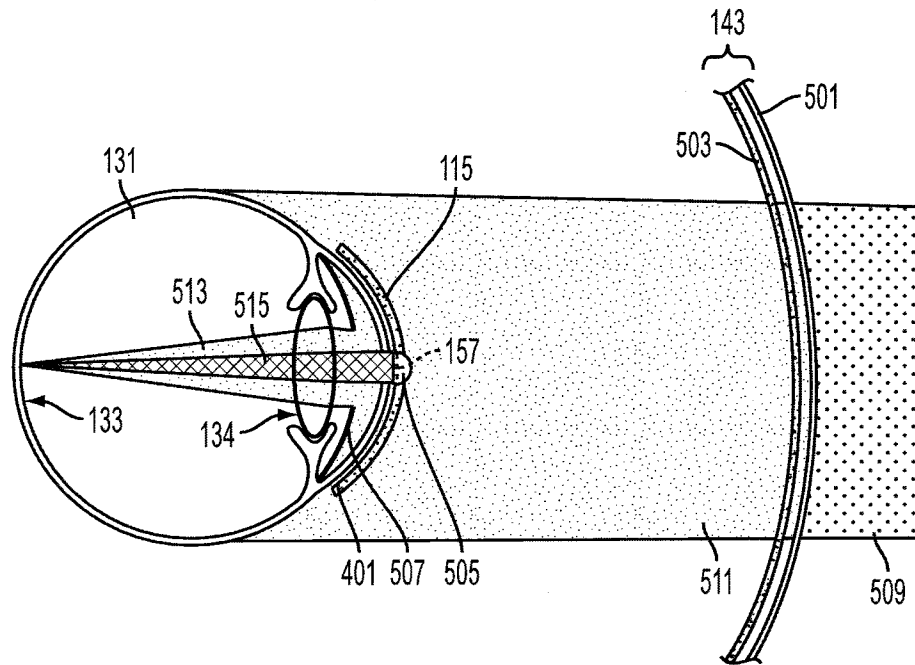

FIG. 5

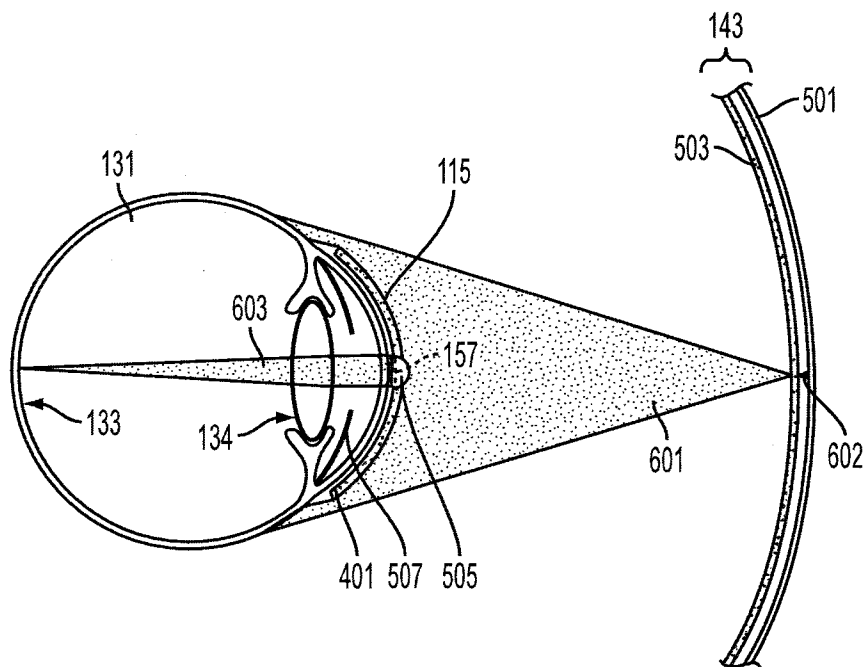

FIG. 6

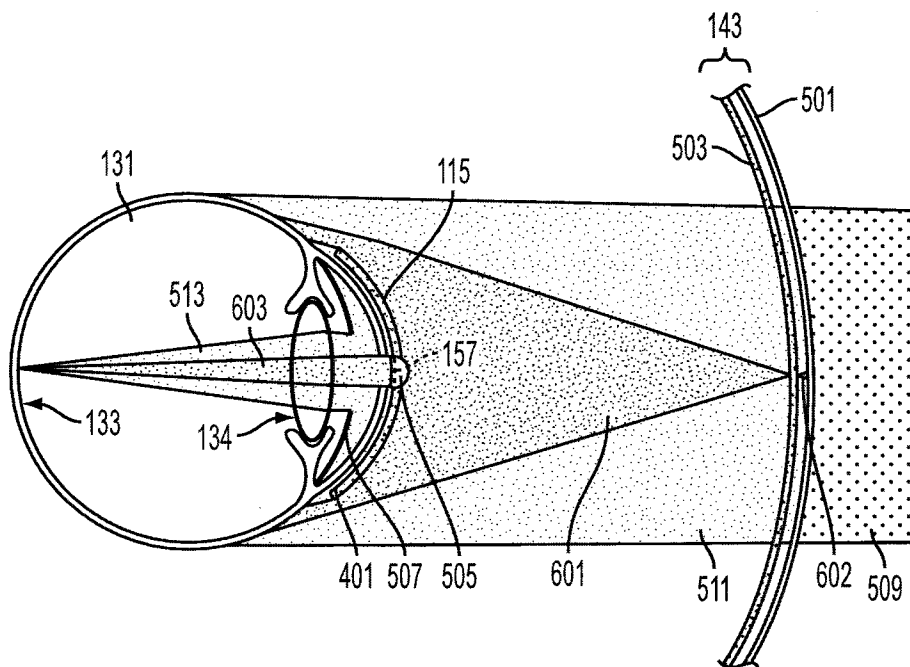

FIG. 7

14/18

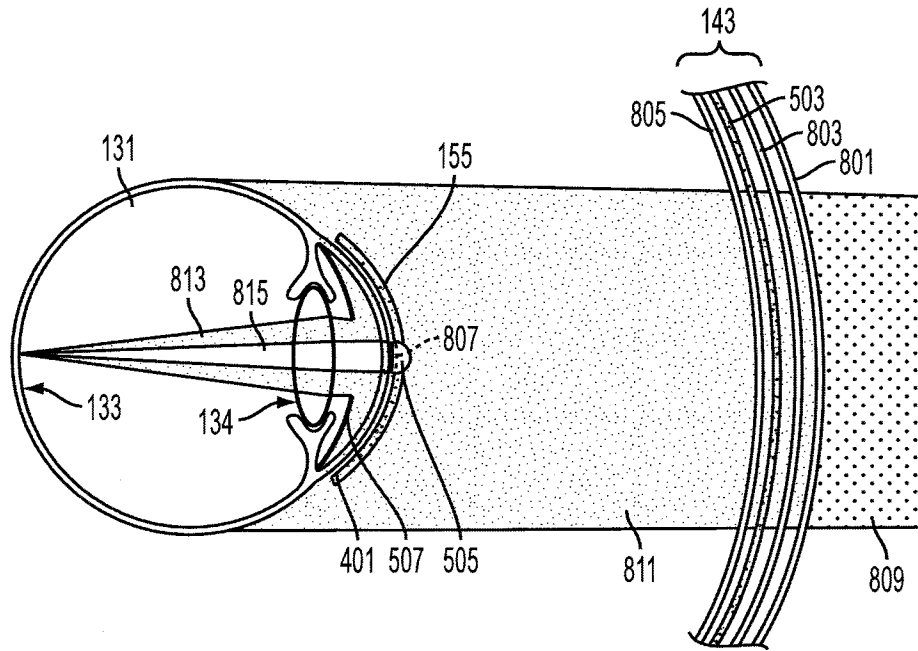

FIG. 8

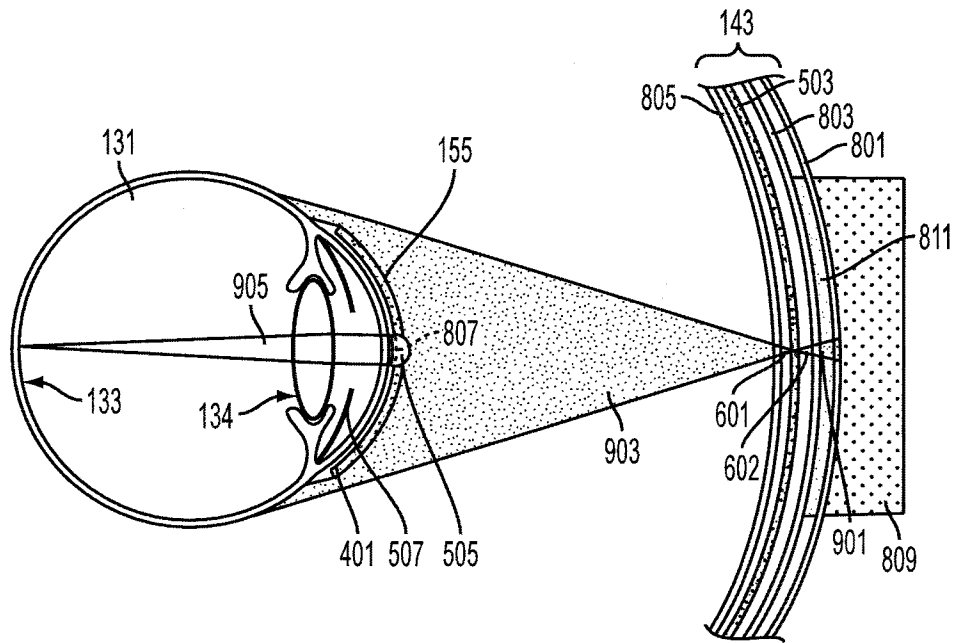

FIG. 9

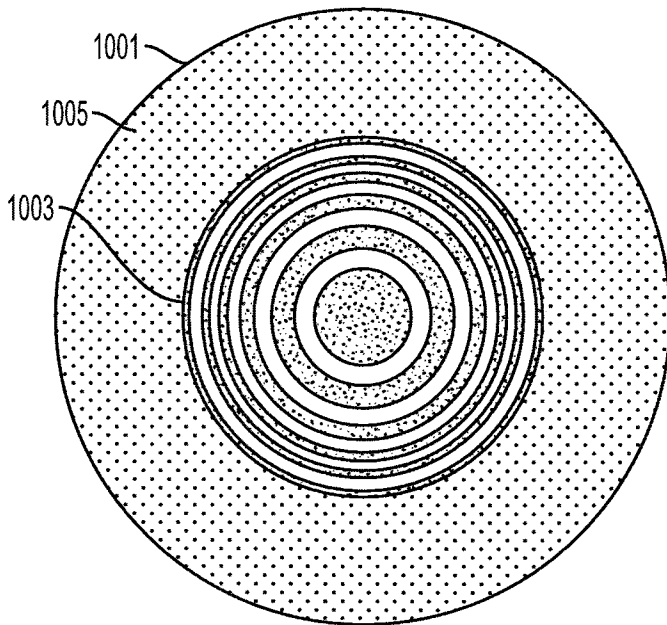

FIG. 10A

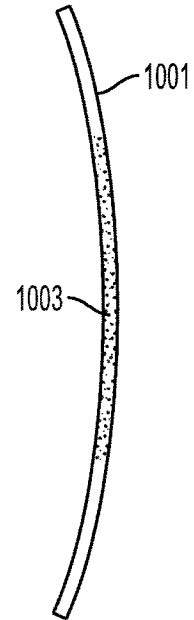

FIG. 10B

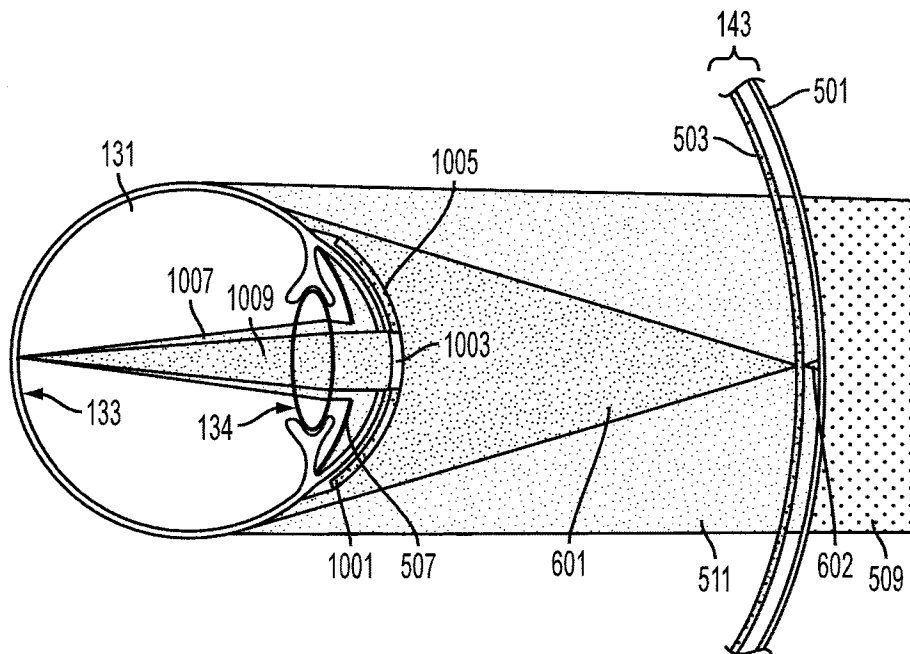

FIG. 11

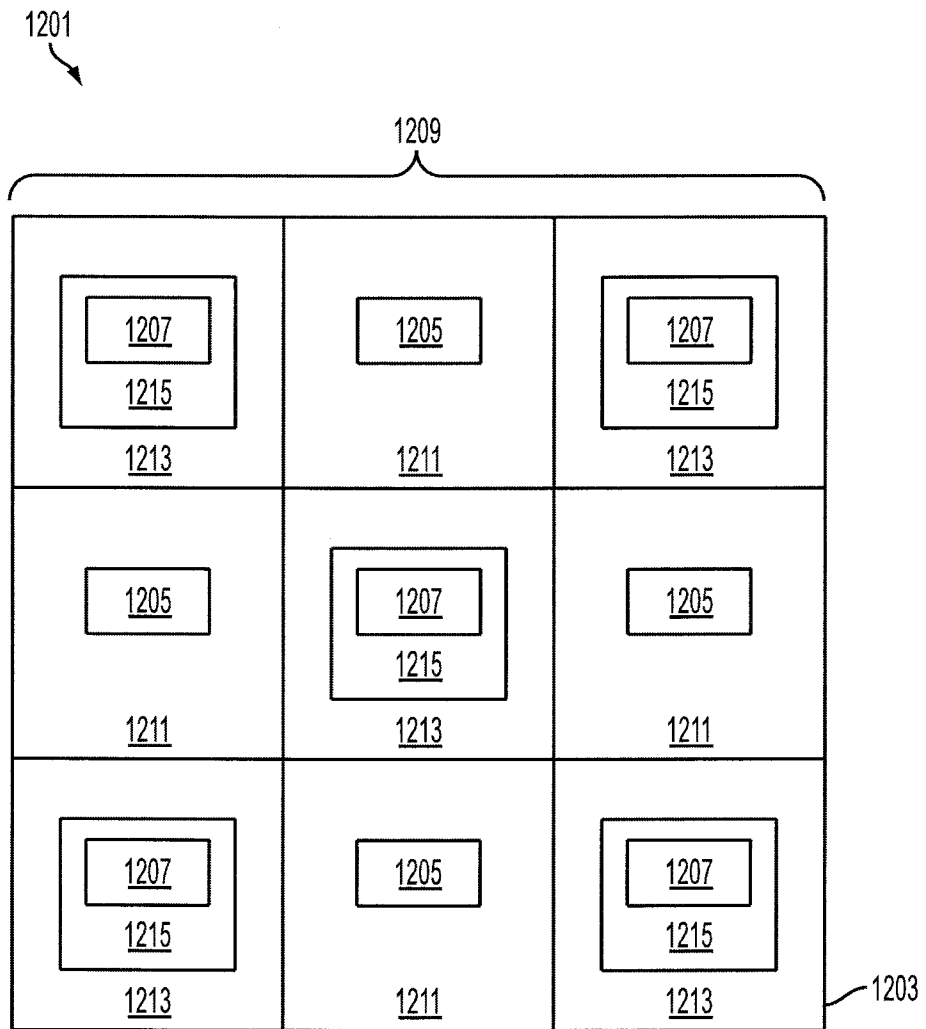

FIG. 12

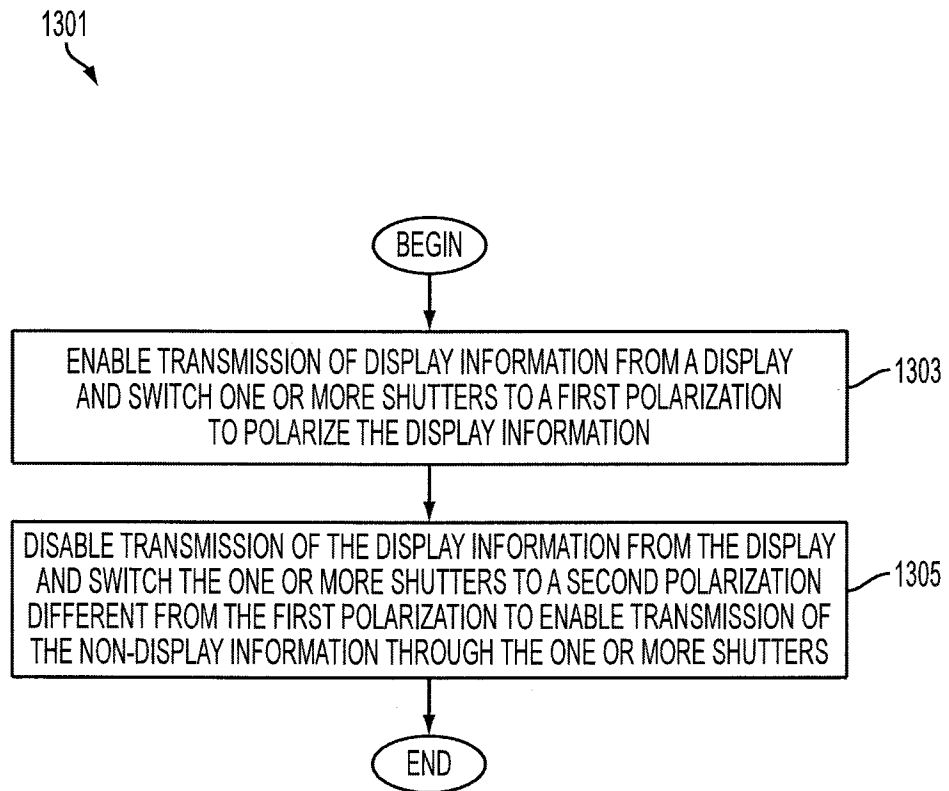

FIG. 13

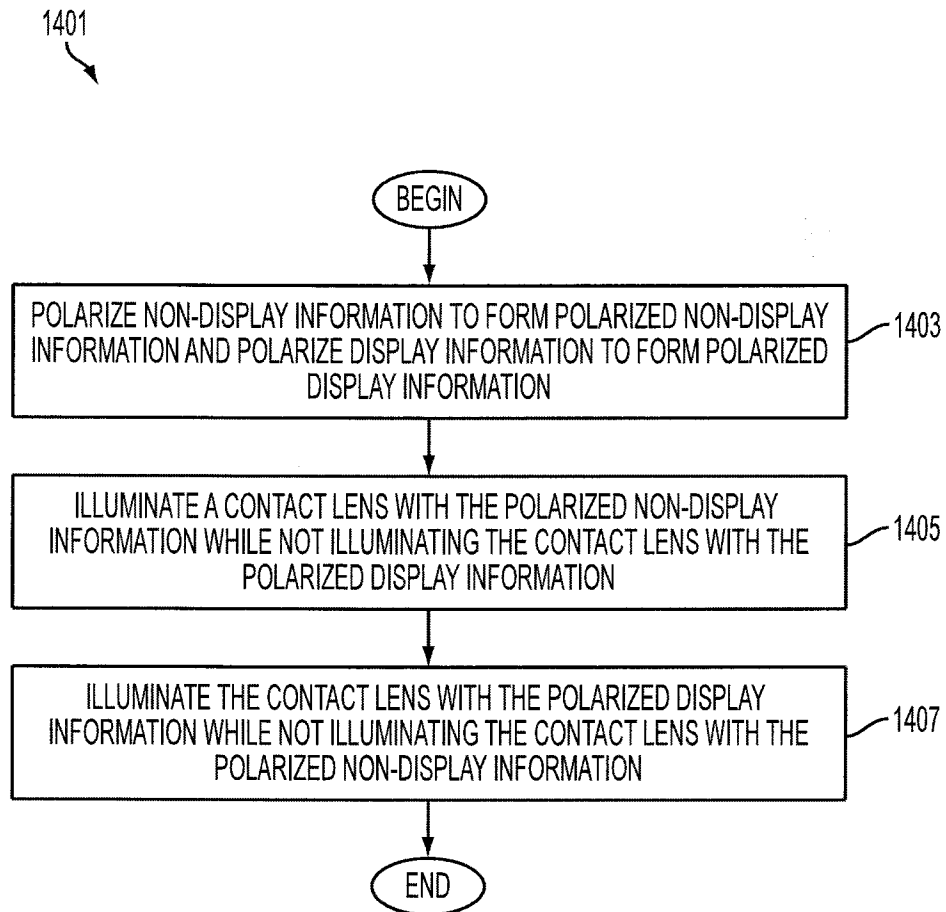

FIG. 14