

B. MORISON.
Weighing Machine.

No. 641.

Patented March 17, 1838.

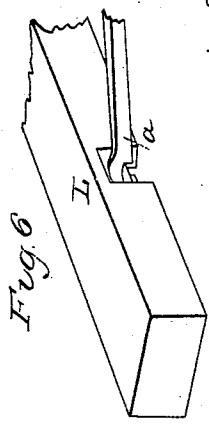
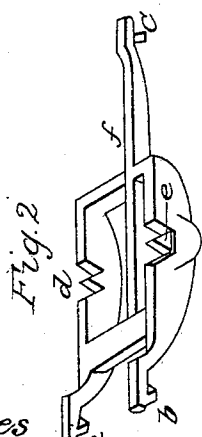
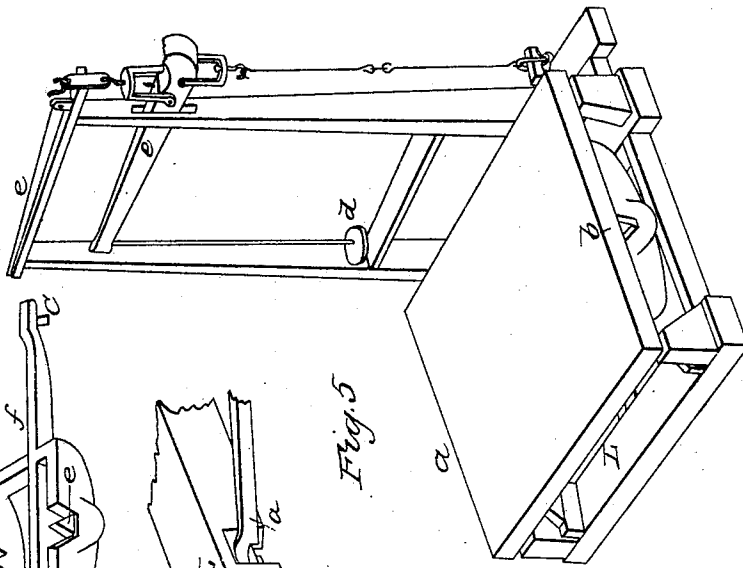
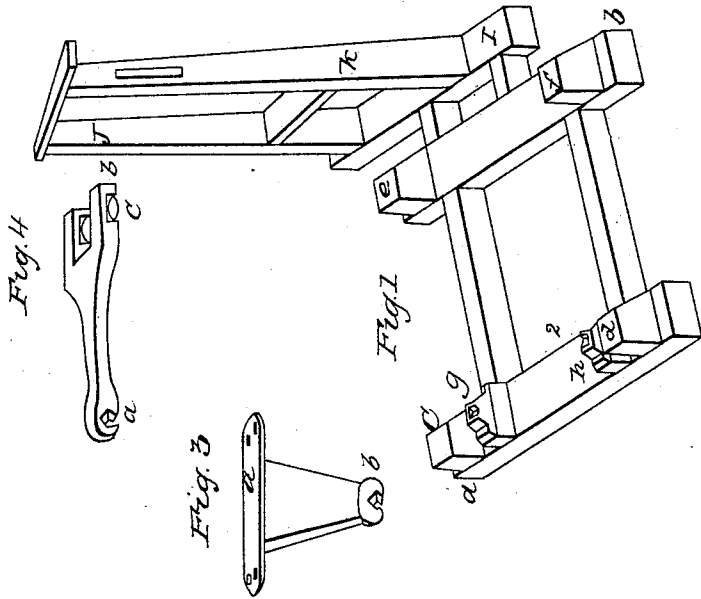

Witnesses
J. H. Bond
Jas. Brown

Inventor
B. Morison

UNITED STATES PATENT OFFICE.

B. MORISON, OF MILTON, PENNSYLVANIA.

PLATFORM-BALANCE FOR WEIGHING.

Specification of Letters Patent No. 641, dated March 17, 1838.

To all whom it may concern:

5 Be it known that I, B. MORISON, of Milton, in the county of Northumberland and State of Pennsylvania, have invented a new and Improved Weighing-Machine; and I do hereby declare that the following is a full and exact description.

10 The nature of my invention principally consists in the application of what I call the parallel principle, to a lever of the second kind, and so combining them as to secure a platform thereon in a manner suitable for weighing.

15 To enable others skilled in the art to make and use my invention, I will proceed to describe its construction and operation.

I construct a square frame A, B, Fig. 1, about three feet wide, of strong wood, about forty five inches thick; upon each corner I erect a post about ten inches high as represented by C, D, E, and F. These are for the purpose of supporting the platform when not in use for weighing, or when it is being loaded. Just inside of the posts C, and D, I erect two other posts G, and H, which are for the purpose of supporting the fulera or resting points of the lever, and are about an inch or two shorter than the four other posts. To the opposite end of this frame, I attach a piece of timber I, and erect thereon two posts J, and K; (one post rising from the end of the timber I, and the other from about the middle of the frame) and these posts I make about four or five feet high, and are intended for the support of the longer end of the lever, and the intermediate lever which is suspended by a flexible rod or chain from a lever of the first kind the fulcrum of which rests upon a horizontal piece of timber secured upon the posts J, and K. I use but one lever under the platform for the purpose of supporting it, and construct it of cast iron and in the form of a frame as represented by Fig. 2. This lever, at the parts A, B, and C, is raised, and at D, and E, depressed, so that the points or edges thereat may be about an inch long, having their ends on a line or plane with each other. I construct this lever, which is of the second kind, a little more than three feet in length, so that the distances of the points or edges from A, to D, and from B, to E, shall be exactly alike and each about half the distance which may be from D, E, to C; or, in other words, about in the proportion of one foot to two. The width of this lever, or the

distance from A, to B, and from D, to E, is about two feet; and the arm F, inserted, at about one third of the width of the lever, from one side, so as to leave room for the vertical piece (A, B, Fig. 3) to be attached to the center of the platform. Upon the top of each post G, and H, Fig. 1, a cast-iron or steel eye is secured so that the points A, and B, of the main lever may rest securely therein, yet without binding—and upon the bottom of the platform two similar blocks of iron or steel are secured near each side at A, and B, Fig. 5, so that the platform may rest securely, yet without binding, upon the two points D, and E, of the lever, Fig. 2, the platform being kept in a horizontal position by means of the vertical rod attached thereto, and the horizontal piece A, B, Fig. 4.

60
65
70
75
80
85
90
95
100
105
110
“The parallel principle” I construct thus: A piece of iron shaped as represented by A, B, Fig. 3, and about a foot long, is bolted firmly to the center of the bottom of the platform, in a vertical position, so that the end B, of the horizontal piece of iron A, B, Fig. 4, may embrace it near the bottom, and be kept in this position by means of a piece of steel C, passing through them (tightly in the arms of the horizontal piece, but loosely in the hole B, of the vertical one) so that the steel piece, having two sharp edges, may have about an eighth of an inch play (right and left) upon these edges—there is a little play also allowed between the arms of the horizontal piece at its place of connection with the vertical one. The end A, of the horizontal piece has an opening from the bottom of exactly the same width as the hole in the vertical piece at B, and works loosely upon another piece of steel (of the same width and shape as the piece at C,) which is let into and secured in the middle of one end of the frame (A, B, Fig. 1) at L. The hole in the vertical piece at B, as also in the horizontal one at A, may be circular, or square with their one diagonal horizontal. The length of the horizontal piece must be such as will allow the distance from the center of the notch A, to the center of the piece of steel C, to be exactly the distance which may be between the edges of the points A, and D, or B, and E, Fig. 2. When the main lever is put in its proper position upon the eyes on the posts G, and H, Fig. 1, and the platform is placed thereon, and the one end of the horizontal piece is put in on the steel plate at L, while the other end is connected

with the vertical piece secured to the bottom of the platform, the center of the hole in the vertical piece and the edges of the steel at L, must be exactly in a line parallel with the points or edges A, D, and B, E, of the lever, Fig. 2—while an imaginary perpendicular line, striking the center of the eyes of the platform and the center of the hole in the lower end of the vertical piece, must be parallel with another imaginary perpendicular line striking the center of the eyes upon the posts G, and H, Fig. 1, and the center of the steel plate at L,—thus forming “the parallel principle.” I construct the points or edges of motion of the main lever, as also the edges of motion belonging to or connected with the vertical and horizontal pieces, of steel, hardened and polished, and the eyes or grooves and holes in which the edges or points move, of cast-iron, chilled and polished.

The other appendages of “the parallel weighing machine,” are such as are commonly applied to other platform scales now in use. I construct the points of motion of the small weighing lever C, Fig. 5, (which passes freely through a mortise or hole in one of the posts) in the proportion of one to fifteen, so that the weight of about two pounds placed upon the small dish D, suspended therefrom, will balance about one hundred placed on the platform. It is intended either that a dish, as at D, be suspended from a fixed point in the end of the small lever, for the purpose of placing thereon the weights; or, that a movable pea or peas be used upon the same in suitable notches; or, that they both be used together. A machine of the above given size and strength will be sufficiently strong for weighing a ton, and at the same time be so delicate as to be turned by two ounces or less placed on the large platform. The above size and proportions are of course to be varied from, to suit the various purposes for which the weighing machine is intended to be used; though it is thought that the height given (about fifteen inches) will be the most convenient height for the platform of a scale capable of sustaining a ton, and at the same time adapted for moving from place to place.

When the platform is intended to be level, or on a plane, with a floor, as is sometimes required for warehouses, out-doors, or for mills, &c., and particularly when required to be placed under the flour-packer of a mill, the horizontal part of the frame-work of Fig. 1 may be dispensed with, and the fulcrum of the main lever made to rest on eyes secured upon the joist of the floor, while the horizontal piece, which connects with the vertical one for steadying the platform, may work in a mortise made in a post to be placed immediately under the joist support-

ing the fulcrum, and, particularly when constructed immediately under the flour-packer of a mill, four or more adequate posts or supporters must be applied below, from the next floor or otherwise, for the purpose of supporting the platform free from the points of motion of the lever, during the time of loading or packing. In all cases, when the platform is being loaded, it is intended that the platform should rest firmly, and free from the edges or points of the main lever, upon the vertical posts or supporters always to be secured under the platform, so that no injury may be sustained by the points or edges by roughly or carelessly loading the platform; and when sufficiently loaded, to be raised therefrom (from the supporters) upon the points or edges of the lever (A, B, Fig. 5) by means of the lever E.

For a common sized movable weighing machine, the vertical piece A, B, Fig. 3, may be about ten or twelve inches long, but when the machine is to be stationary, as when the platform is made on a plane with the floor of a warehouse, mill or elsewhere, it is intended to make the vertical piece (A, B, Fig. 3) considerably longer (still preserving the parallel relation thereof), because the longer this piece may be, the less will be the pressure upon its place of connection with the horizontal piece, and the less liable will the platform be to slip from the edges of the lever; in such cases, therefore, the vertical piece may extend down to any convenient length. When still greater stability of the platform is required, two vertical and two corresponding horizontal pieces are intended to be applied to the machine—the two vertical pieces being secured to the platform, one near each eye thereof, and the two horizontal pieces, one near each post which supports the fulcrum; their parallel relation to the main lever and points, being still preserved; so that there will be less liability in the platform to twist or slip from the points or edges of the main lever, when the loading is placed too much on one corner or side of the platform. The arm F, of the lever, may in this case, be in the middle of its frame.

The principal advantages which “the parallel weighing machine” has over those platform scales now in use, are, its comparative cheapness, simplicity and durability. The best platform scales now in use, have, under the platform, from twelve to sixteen points of motion during their operation, while the above described has but seven; which, in connection with its simplicity, and arrangement for relieving the points or edges on the main lever, and rendering the platform at the same time firm, renders it much less liable to get out of order—and, again, the cost of constructing “the parallel weighing machine,” with weights sufficient for weigh-

ing any amount not greater than a ton, is but about fifteen dollars—while any one of the platform scales now in use, and capable of weighing the same draft, cannot be
5 bought of the manufacturers for less than sixty or seventy dollars. These advantages, it is thought, will give “the parallel weighing machine” the preference (for most purposes) over all others, and therefore justify
10 the procuring of Letters Patent.

What I claim as my invention and desire to secure by Letters Patent, is—

1. The application of “the parallel principle” to a lever of the second kind, (viz. to
15 a beam having its weight between the ful-

crum and power,) for the purpose of weighing.

2. The combination herein described, whereby the points or edges of the main lever are, at any time, capable of being freed
20 from the pressure of the platform and what may be laid thereon; and the platform at the same time be made to rest firmly and securely upon supporters, or posts beneath the same.

B. MORISON.

Witnesses:

J. H. BROWN,

C. GOODLANDER.