

E. A. REEVES.
 PREPAYMENT GAS METER.
 APPLICATION FILED DEC. 5, 1908.

1,000,626.

Patented Aug. 15, 1911.

3 SHEETS—SHEET 2.

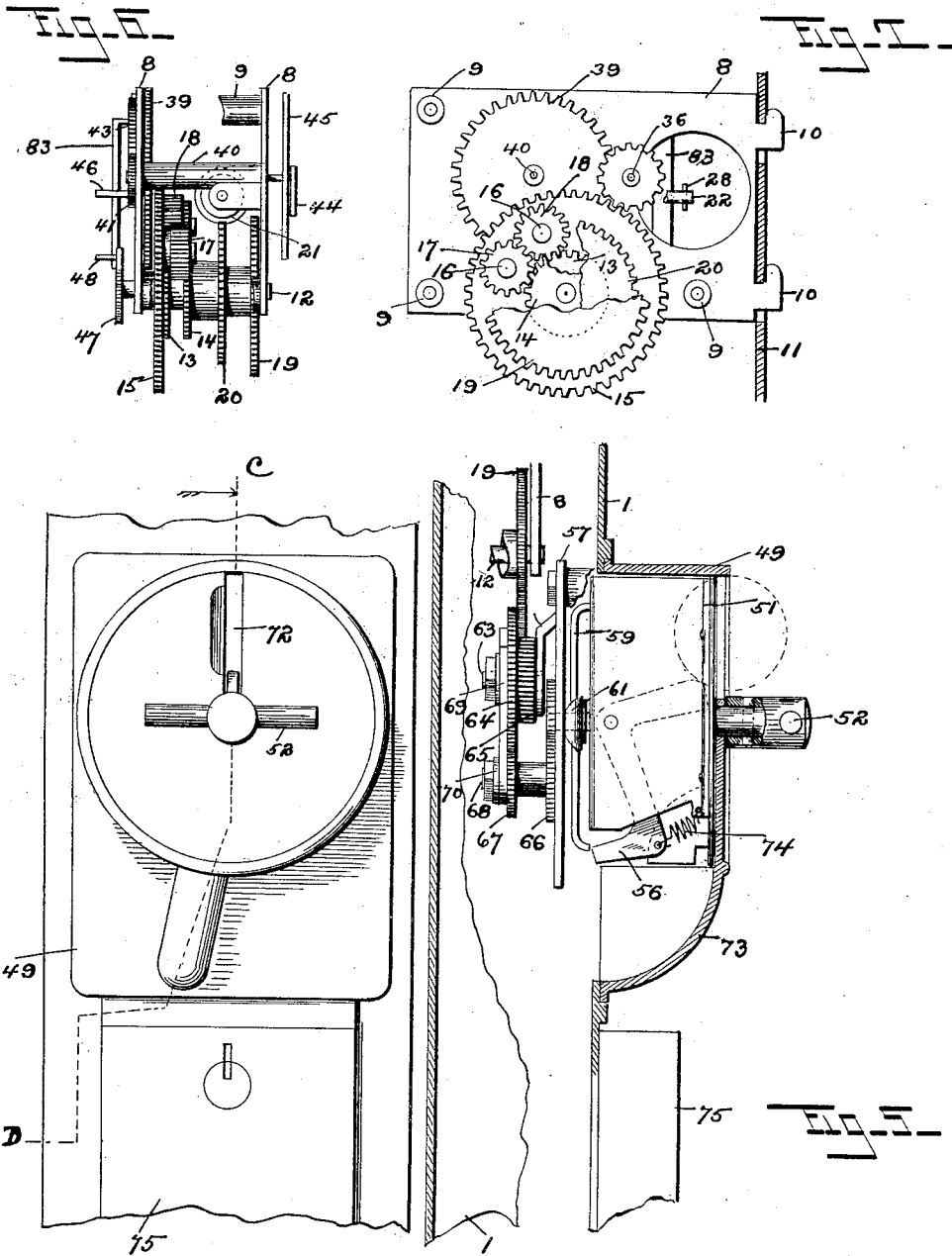

WITNESSES:

Alfonse N. Mark
Antoine Walkauer

INVENTOR.

Eduard A. Reeves

BY

George P. Hall

ATTORNEY.

UNITED STATES PATENT OFFICE.

EDWIN A. REEVES, OF MILFORD, CONNECTICUT.

PREPAYMENT GAS-METER.

1,000,626.

Specification of Letters Patent. **Patented Aug. 15, 1911.**

Application filed December 5, 1908. Serial No. 466,117.

To all whom it may concern:

Be it known that I, EDWIN A. REEVES, a citizen of the United States, residing at Milford, in the county of New Haven and State of Connecticut, have invented certain new and useful Improvements in Prepayment Gas-Meters, of which the following is a specification, reference being had therein to the accompanying drawings.

My invention relates to new and useful improvements in prepayment gas meters, and refers more particularly to coin actuated mechanism attachments for such meters although not necessarily limited to such use.

It is the object of my invention, among other things, to provide means for adjusting the mechanism whereby varying quantities of gas may be procured for the same unit price, which is determined by the varying rates of gas per thousand feet; means whereby the total amount of prepaid gas is only limited by the capacity of the registering mechanism of the meter; and to accomplish these and other desirable results with mechanism that is simple and economical, capable of being readily assembled, and positive in its operation.

To these, and other ends, my invention consists in the prepayment gas meter having certain details of construction and combinations of parts as will be hereinafter described and more particularly pointed out in the claims.

Referring to the drawings in which like numerals of reference designate like parts in the several figures; Figure 1 is a plan view of the attic of a meter with my improved mechanism attached thereto, the shell of said meter being shown in section; Fig. 2 is a section of the valve case upon line A—B of Fig. 1; Fig. 3 is a fragmentary perspective view of one of the shafts; Fig. 4 is a front view of the coin case; Fig. 5 is a sectional side view thereof upon line C—D of Fig. 4; Fig. 6 is an elevation of the valve operating mechanism; Fig. 7 is a view thereof looking from the right of Fig. 6 with one of the side plates removed and portions of some of the gears broken off; Fig. 8 is a rear view of the coin case and coin carrier with the mechanism connected therewith; Fig. 9 is a similar view with some of the mechanism removed; Fig. 10 is a sectional elevation of the coin carrier upon line E—F of Fig. 9, showing the location of the parts when a coin is inserted therein; Fig. 11 is a side eleva-

tion of the gear mechanism shown in Fig. 8; Fig. 12 is a side elevation of the valve case; Fig. 13 is an elevation of the valve operating mechanism looking from the left of Fig. 6; and Fig. 14 is a cross section of the coin carrier upon line G—H of Fig. 9.

In the operation of my invention a coin is placed within a rotatably mounted carrier and operates a lever mounted therein which engages an arm connected with a train of gears, and from which the valve is opened a predetermined distance. The valve is closed through the rotation of the drive shaft, a predetermined number of revolutions of such shaft automatically returning the valve to its closed position.

Provision is made by a separable connection between the valve and its operating mechanism for operating the same, whereby the predetermined quantity of gas paid for is only limited by the registering capacity of the meter.

In the drawings the numeral 1 designates the meter body, 2 the levers which are common to every gas meter, 3 the drive shaft which is also common to all meters and is shown herein as being supported by the standards 4 and 5, which are both fastened to the attic floor 6, and 7 is the recording mechanism. The drive shaft 3 is rotated from the levers 2 and operates the recording mechanism 7 which registers the amount of gas consumed by means of the usual indicator dials upon the face of the meter.

The valve operating mechanism is mounted between two side plates 8 that are held apart by the posts 9, each plate being provided with the catches 10 to provide ready means for attachment to the part 11 of the meter body. Journaled in these plates is the spindle 12 having rotatable thereon the gears 13 and 19 which are secured together, the said gear 19 being operated from the coin controlled mechanism hereinafter described. Adjacent thereto and rotatable upon the hub between the gears 13 and 19 is the gear 14 of the same diameter and pitch as the gear 13, and fixed thereto is the gear 20 which meshes into a worm 21 fixed on a shaft 22 that is rotatably mounted in brackets 23 on one of the side plates 8. Upon the opposite side of the gear 13 from that of the gear 14, loosely mounted upon the spindle 12, is the gear 15.

Rotatably mounted upon the pintles 16, fixed within the gear 15, is the epicycloidal

train, comprising the pinions 17 and 18 which mesh into each other, and the pinion 17 having engagement also with the gear 14, and the pinion 18 having engagement with the gear 13.

Journaled in the standard 5 at one end, and in the bearing 25 fixed in the part 11 at the other end, is the shaft 26 having a slot 27 in the end thereof, into which projects the end of the shaft 22 and the cross pin 28 fixed therein, a breakable connection being thus made between the shafts 22 and 26. Fixed on said shaft is a gear 29, the teeth of which engage the teeth of the worm wheel 30 on the shaft 3, the same being held against endwise movement between the arms of the yoke end of the standard 5.

The valve casing 30 can be made of any desired form, but as herein shown consists of a rectangular box having means connected therewith whereby the inlet pipe 81 from the gas main can be connected thereto at one end and the outlet pipe 82 at the other end. Within the interior of this casing is mounted the valve itself, which comprises a valve disk 31 connected by an arm 33 with a shaft 32 journaled in said valve casing and carrying an arm 34 fixed thereto provided with a slot 35 in the outer end thereof. Journaled between the side plates 8 is a spindle 36 carrying a pinion 37 which meshes into, and is driven by, the gear 15, and a pinion 38 which meshes into and drives a gear 39 which is fixed on the spindle 40 also journaled between the plates 8 and having a pinion 41 thereon which meshes into and drives a gear 42 mounted upon a fixed stud 43. Each of the spindles 36 and 40 carries an indicating finger 44 that rotates in front of the dial 45 fixed to one of the plates 8.

Fixed on the end of the spindle 12 is an arm 47 carrying a laterally projecting pin 48 in the outer end thereof and a similar pin 46 projects laterally from the gear 42. As the spindle 12 is rotated by the coin means, hereafter to be described, in the direction of the arrow shown in Fig. 13, it will cause the gear 13 and arm 47 to rotate in the direction of the said arrow, and as the pin 48 strikes the underside of the arm 34, rotates the shaft 35 and lifts the valve disk 31 off its seat, thus opening the valve, and when fully opened the said pin 48 passes said lever and continues its rotary movement. This valve is automatically closed by the following operation. As the drive shaft 30 is rotated the shaft 26 is also rotated through the worm 30 and worm gear 29, and the gear 20 through the worm 21, and arm 47 through the pinion 17. The arm 47 is thus caused to rotate in the reverse direction than when being rotated from the spindle 12, and in its rotation by the engagement of the pin 48 with the slot 35, the valve disk 31 is re-

turned to its original position through the rock shaft 33 and intermediate connection. This position of the parts is shown by broken lines in Fig. 13. It is apparent that any movement of the rock arm 34 in either direction will open or close the valve 31 according to the direction of its movement, and to open the valve the rock lever is actuated by coin mechanism, hereafter to be described, and closed automatically by mechanism operated by the passage of gas through the meter. As the arm 47 is actuated by the coin mechanism the arm 34 is out of the path of the pin 48 and will so continue as long as coins are being placed in the coin carrier. When the gas paid for has been substantially consumed the pin 46 in the gear 42 engages the arm 34 and moves the slot 35 into the path of the pin 48 so that said pin will enter said slot and during its continued movement will actuate the rock lever 34, as before described.

The location of the pin 46 in the gear 42 is such that the total amount of gas capable of being registered by the indicating mechanism will pass through the meter before said pin 46 engages the rock arm 34, provided all of said gas has been paid for in advance. Otherwise the relation of the pin 46 to the rock lever 34 is such that the amount of gas paid for will pass through the meter before the said pin engages the rock arm 47.

The coin mechanism is contained within the case 49 separably secured to a laterally projecting portion on the meter body 1 and within which is rotatably mounted the coin carrier 51 having a finger pin 52 upon one side and a bearing 53 upon the other side. This carrier is made with a coin opening 54 between the walls thereof and within which is mounted a trip lever 55 having a projecting trip arm 56. Fixed to the back of the coin case 49 is a removable plate 57 within which is rotatably mounted the gear 58 having connected therewith a spreader 59, bent at both ends to form the lips 60 which project into the path of the trip arm 56 when in one of its positions. This spreader is held against overthrow movement by a spring 61. Fixed to an offset arm 62 on said plate 57 is a stud 63, upon which is rotatably mounted the gear 64 and pinion 65, which gear and pinion are preferably integral with each other. Motion is communicated from the gear 58 to the gear 64 and pinion 65 through the intermediate gears 66 and 67 which rotate upon a stud 68 fixed in the ends of the yoke arms 69 and 70. The arm 69 straddles the pin 63 and the arm 70 straddles a post 71 fixed in the plate 57, both of said arms 69 and 70 being adjustably secured to said post and stud. It is apparent that intermediate gears of any other size may be substituted for the gear 66 and

67, and hence the ratio of speed between the gears 58 and 64 can be varied indefinitely. The coin case 49 is so mounted in relation to the valve operating mechanism that the pinion 65 meshes into and drives the gear 19 and thus actuates the spindle 12 in one direction.

In operation the coin is passed through the slot 72 in the face of the coin case 49 and into the coin carrier, and while being forced therein engages the trip lever 55 and moves it from the position shown in Fig. 3 to that shown in Fig. 8, wherein the trip arm 59 is forced into the path of the ends 60 on the spreader 59. The carrier is now rotated through the finger pin 52 in the direction of the arrow shown in Fig. 8 and during the movement of the coin carrier the spreader is moved therewith and through its connection with the gear 58 motion is transmitted to the spindle 12 by the mechanism hereinbefore described and the valve 31 moved off its seat. After about one-half of a revolution has been made and the coin slot in the coin carrier has been brought into register with a pocket 73 in said coin case the spring 74 connecting the trip lever 55 with the coin carrier 51 throws the coin out of said coin carrier into said pocket from which it drops into a receptacle 75 conveniently arranged to receive it. Further rotation of the coin carrier in this direction is prevented by an arm 76 integral therewith which engages a stop pin 77 which is arranged so that said arm is in engagement with said pin when said coin carrier is in register with said pocket. After the movement of the coin carrier has begun the return thereof without the ejection of the coin is prevented by a pawl 78 which is pivotally connected with the case 49 and is in the path of the trip arm 56, the spring 79 connected therewith permitting the same to yield and allow the said trip arm to pass. The stop pin 80 fixed in said case will hold said pawl from moving in the opposite direction and hence will not permit the return of said carrier until after the coin has been ejected therefrom.

There are minor changes and alterations that can be made within my invention, and I would therefore have it understood that I do not limit myself to the exact construction herein shown and described, but claim all that falls fairly within the spirit and scope of my invention.

Having described my invention, what I

claim as new and desire to secure by Letters Patent, is:—

1. In a prepayment attachment for meters; a rotatably mounted coin carrier; a gear concentric with said carrier; a spreader connected with said gear; a coin actuated lever pivotally mounted in said coin carrier having a part thereon which projects into the path of said spreader in one of its positions; a driven gear connected with a fixed part and rotatable about an axis substantially parallel with the axis of said coin carrier; intermediate gears between said first mentioned gear and said driven gear; and pivotally connected and adjustably secured arms for mounting said intermediate gears whereby gears of various diameters may be substituted.

2. In a prepayment attachment for meters; a pivotally mounted coin carrier; a gear rotatable therewith; a spreader connected with said gear; a coin actuated lever in said coin carrier, having a part thereon which projects into the path of said spreader; a driven gear rotatable about an axis substantially parallel with the axis of said coin carrier; a train of gears connecting said first mentioned gear with said driven gear; and means for mounting said train of gears whereby the ratio of speed between said first mentioned gear and driven gear may be varied.

3. In a prepayment attachment for meters; a coin case having a coin slot there-through; a coin carrier rotatably mounted therein; a coin actuated lever within said carrier; a gear connected with said carrier; a spreader connected with said rotary gear and having lips at both ends thereof which project into the path of said coin actuated lever when a coin is in said carrier; a pawl connected with a fixed part for preventing the return of said coin carrier after the said lever has engaged said spreader; a driven gear rotatably mounted upon a fixed part with its axis substantially parallel with said coin carrier; and adjustably mounted intermediate gears between said first gear and said driven gear.

In testimony whereof I affix my signature in presence of two witnesses.

EDWIN A. REEVES.

Witnesses:

GEORGE E. HALL,
FLORENCE H. MONK.