

(12) **United States Patent**
Clarke et al.

(10) **Patent No.:** **US 10,233,618 B2**
(45) **Date of Patent:** **Mar. 19, 2019**

(54) **FAUCET INCLUDING CONTROL ARM**

(71) Applicant: **Kohler Co.**, Kohler, WI (US)

(72) Inventors: **Gary N. Clarke**, Sheboygan, WI (US);
Rodney L. Weekley, Mequon, WI (US);
Jacob R. Frye, Sheboygan, WI (US)

(73) Assignee: **KOHLER CO.**, Kohler, WI (US)

(*) Notice: Subject to any disclaimer, the term of this patent is extended or adjusted under 35 U.S.C. 154(b) by 0 days.

(21) Appl. No.: **15/611,414**

(22) Filed: **Jun. 1, 2017**

(65) **Prior Publication Data**

US 2017/0350104 A1 Dec. 7, 2017

Related U.S. Application Data

(60) Provisional application No. 62/345,372, filed on Jun. 3, 2016.

(51) **Int. Cl.**
E03C 1/00 (2006.01)
E03C 1/04 (2006.01)

(52) **U.S. Cl.**
CPC **E03C 1/0404** (2013.01); **E03C 2001/0414** (2013.01)

(58) **Field of Classification Search**
CPC E03C 1/0405; E03C 2001/0414; E03C 2001/0415
USPC 239/587.3; 4/567, 568, 654, 638; 137/801

See application file for complete search history.

(56) **References Cited**

U.S. PATENT DOCUMENTS

4,709,715 A * 12/1987 Knight A47L 17/00
134/177
6,450,425 B1 * 9/2002 Chen E03C 1/06
239/587.4
8,869,821 B2 * 10/2014 Laera E03C 1/0404
137/355.16
2008/0196160 A1* 8/2008 Alder E03C 1/0404
4/678

FOREIGN PATENT DOCUMENTS

CN 1888501 A 1/2007
CN 202215815 U 5/2012
CN 204114282 U 1/2015
CN 204647419 U 9/2015

* cited by examiner

Primary Examiner — Viet Le

(74) *Attorney, Agent, or Firm* — Foley & Lardner LLP

(57) **ABSTRACT**

A faucet that includes a base, a sprayhead, a flexible hose and a control arm. The base is mountable to a mounting surface. The sprayhead is movable relative to the base and is configured to emit water in at least one spray pattern. The flexible hose connects the sprayhead and the base. The control arm includes a first end and a second end, wherein the first end is pivotally connected to the base to allow rotation of the control arm relative to the base, and wherein the second end is detachably coupled to the sprayhead such that in a docked position, movement of the control arm moves the sprayhead relative to the base, and such that in a detached position, the sprayhead is movable relative to the base and the control arm.

20 Claims, 17 Drawing Sheets

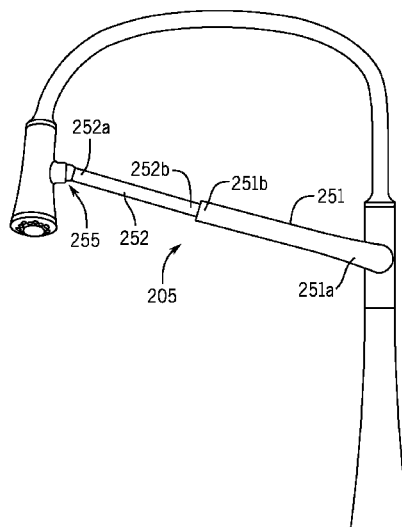

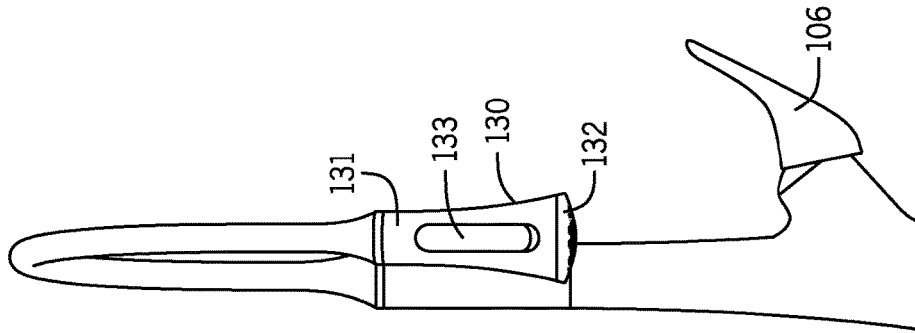

FIG. 2

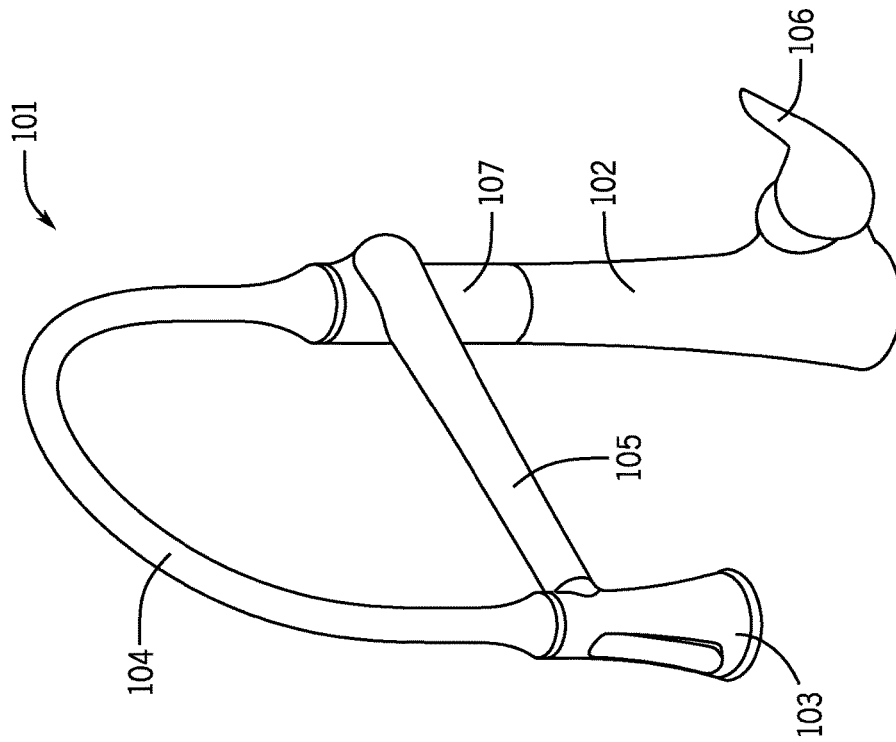

FIG. 1

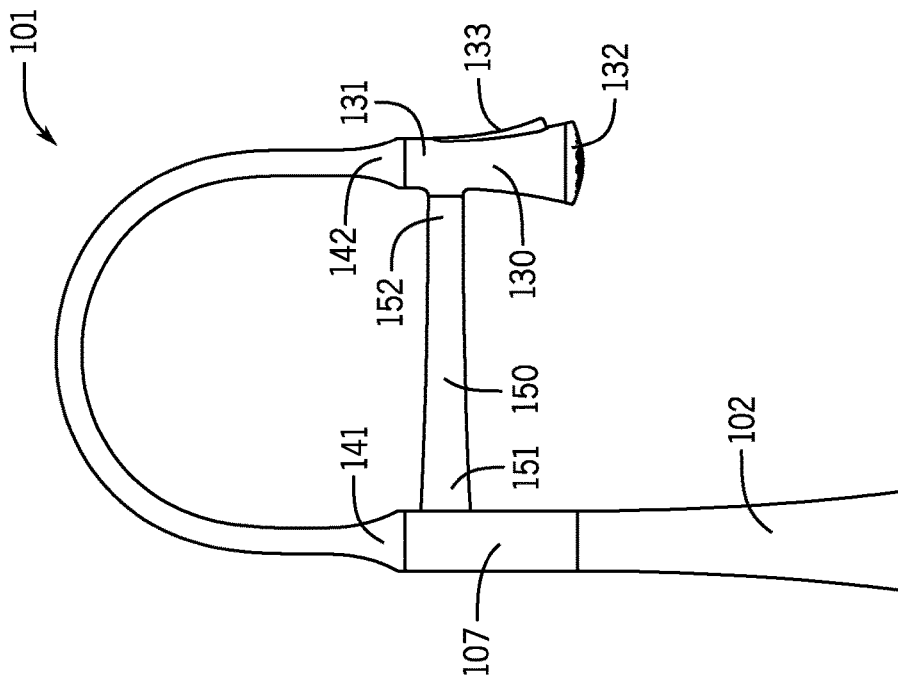

FIG. 3

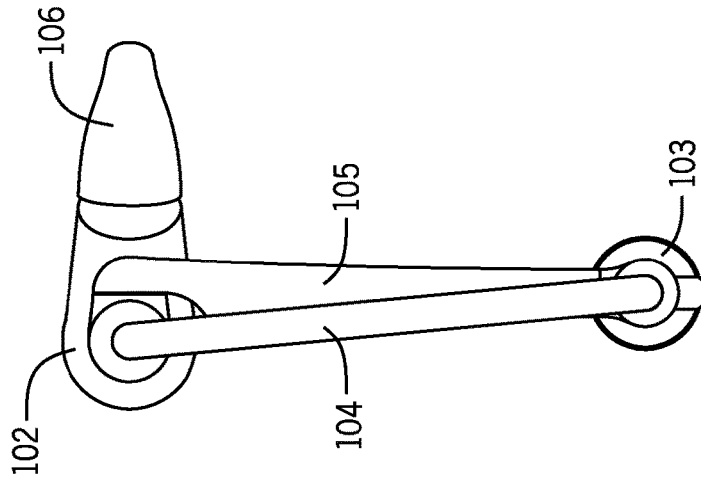

FIG. 4

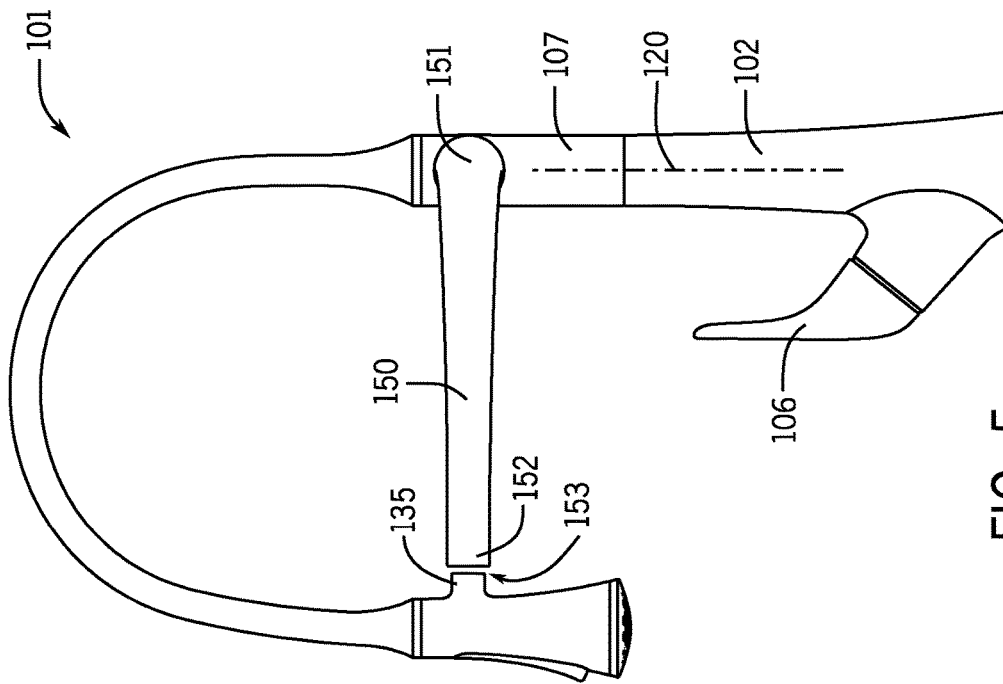

FIG. 5

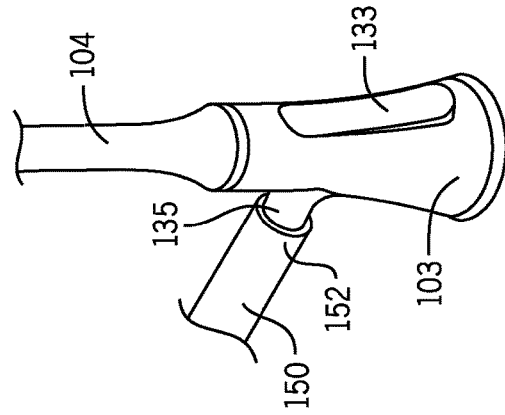

FIG. 6

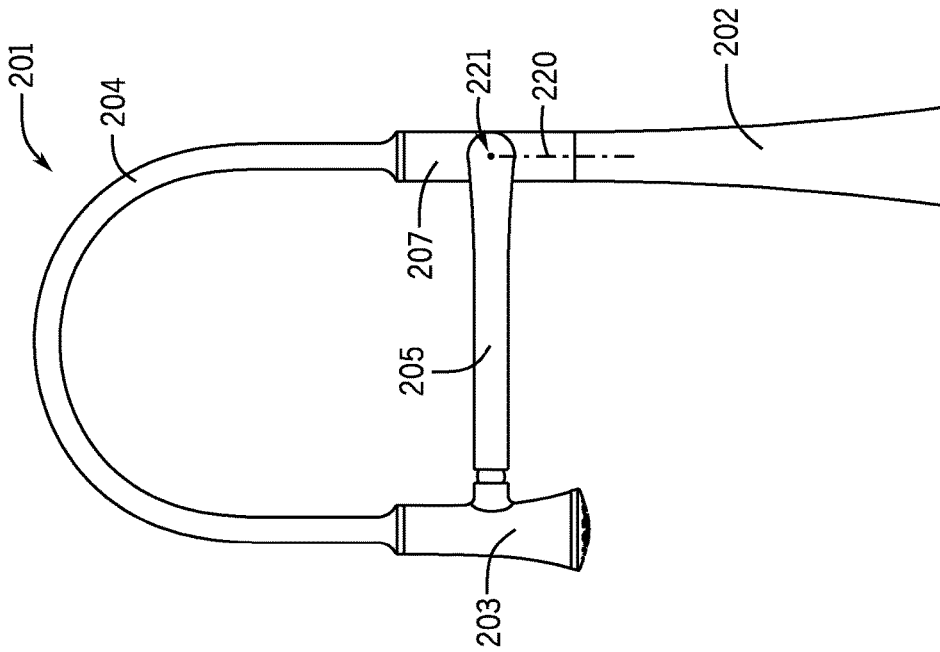

FIG. 9

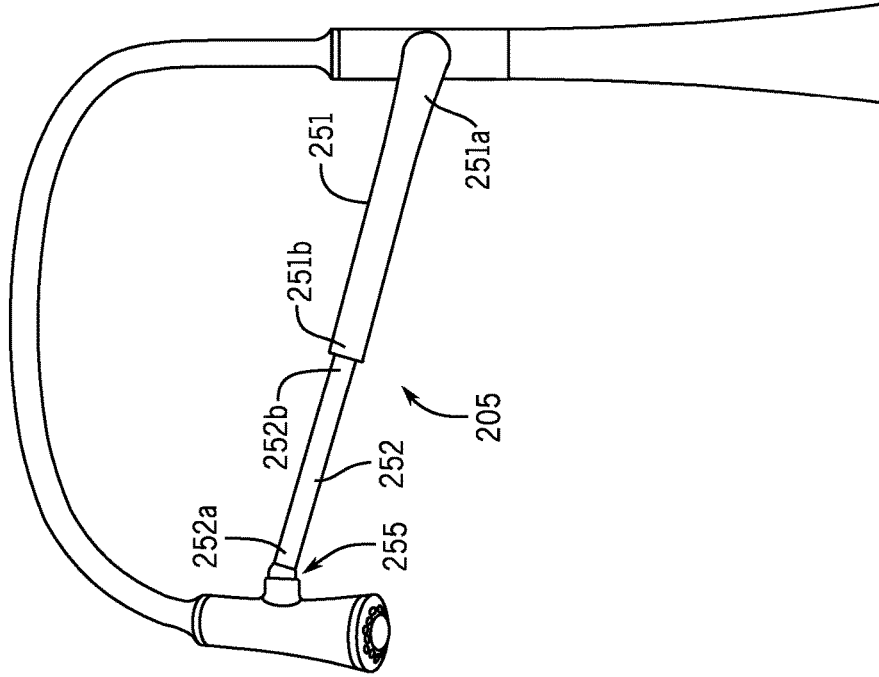

FIG. 10

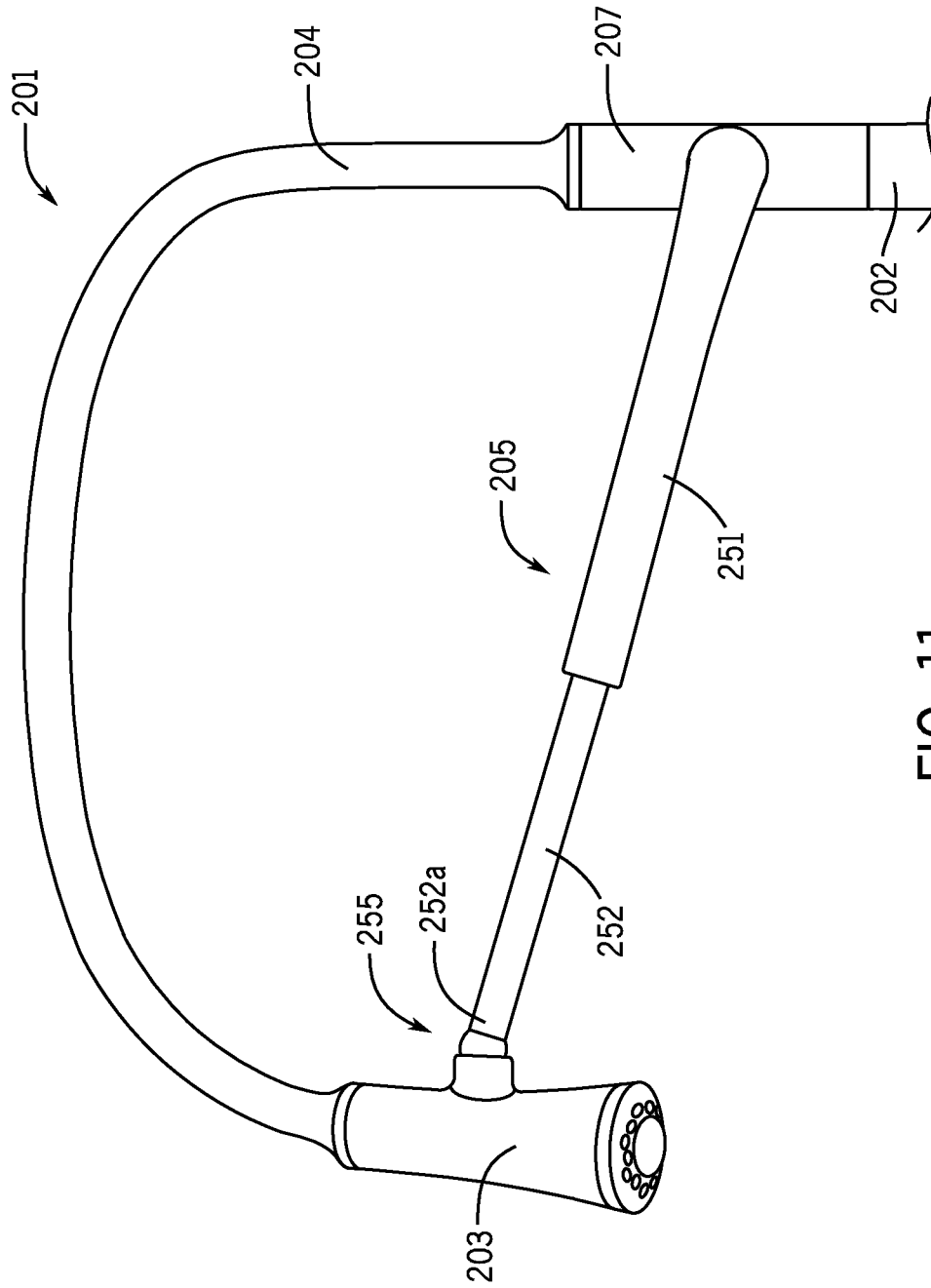

FIG. 11

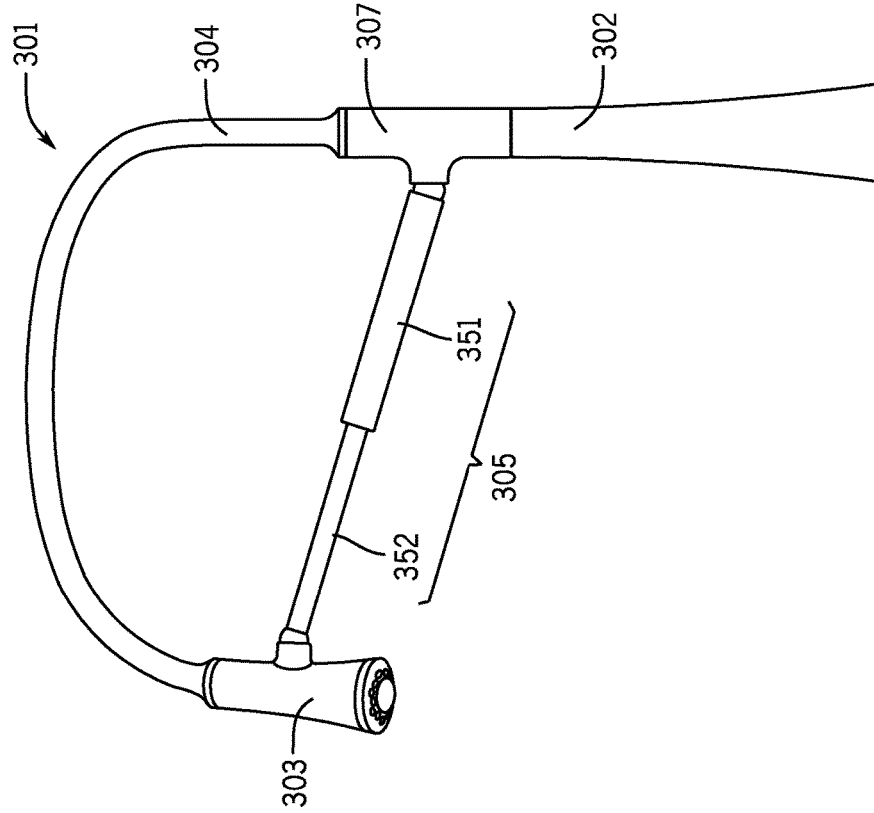

FIG. 13

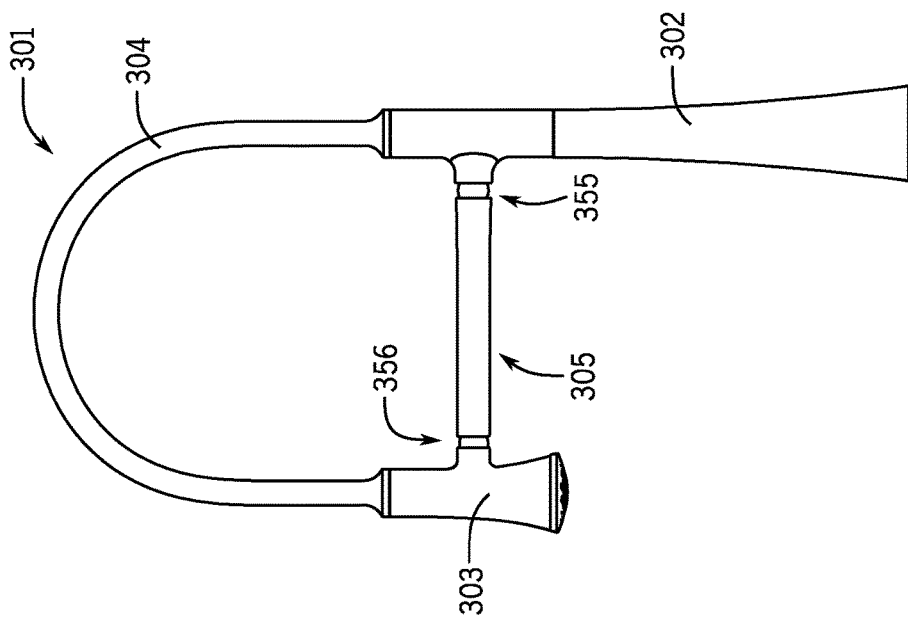

FIG. 12

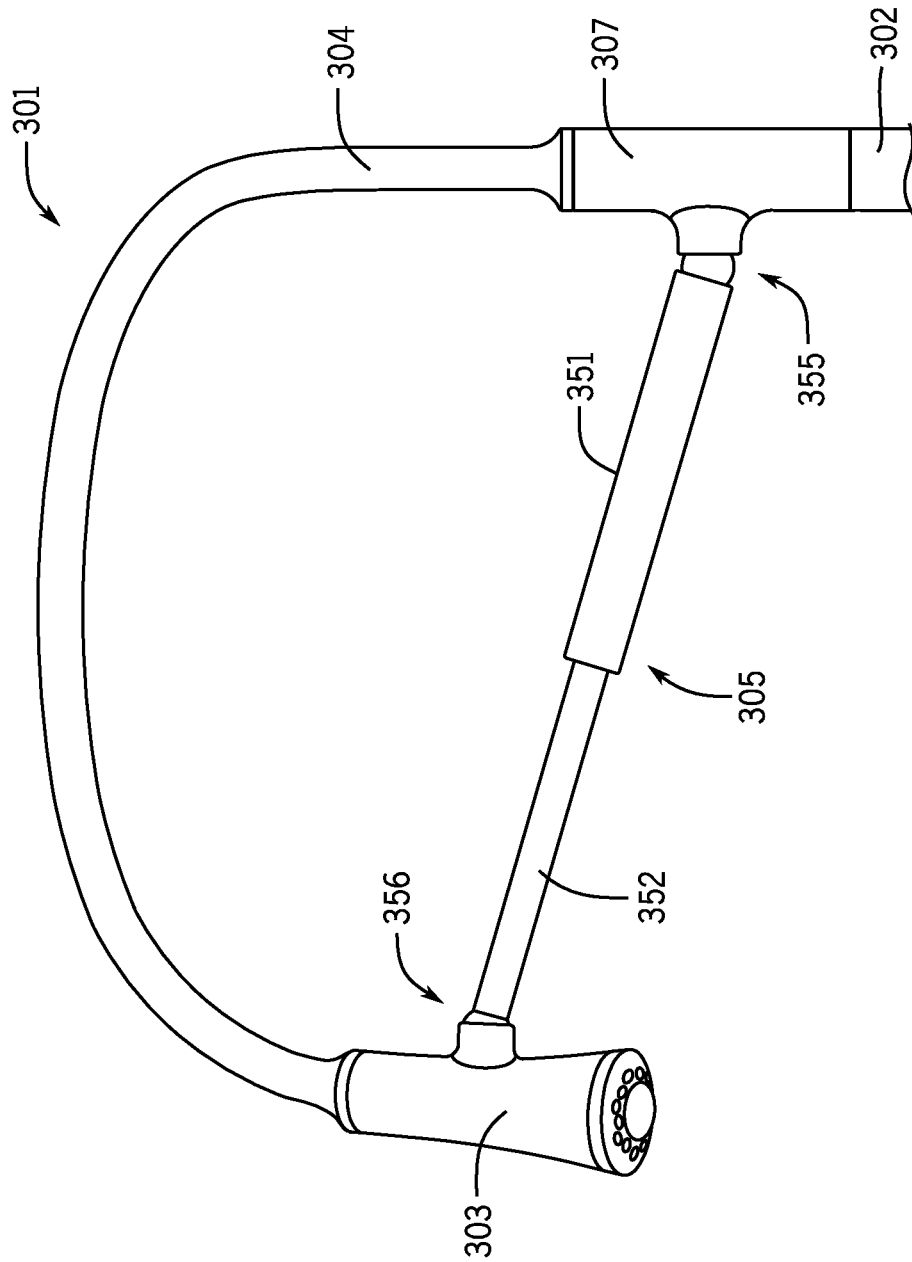

FIG. 14

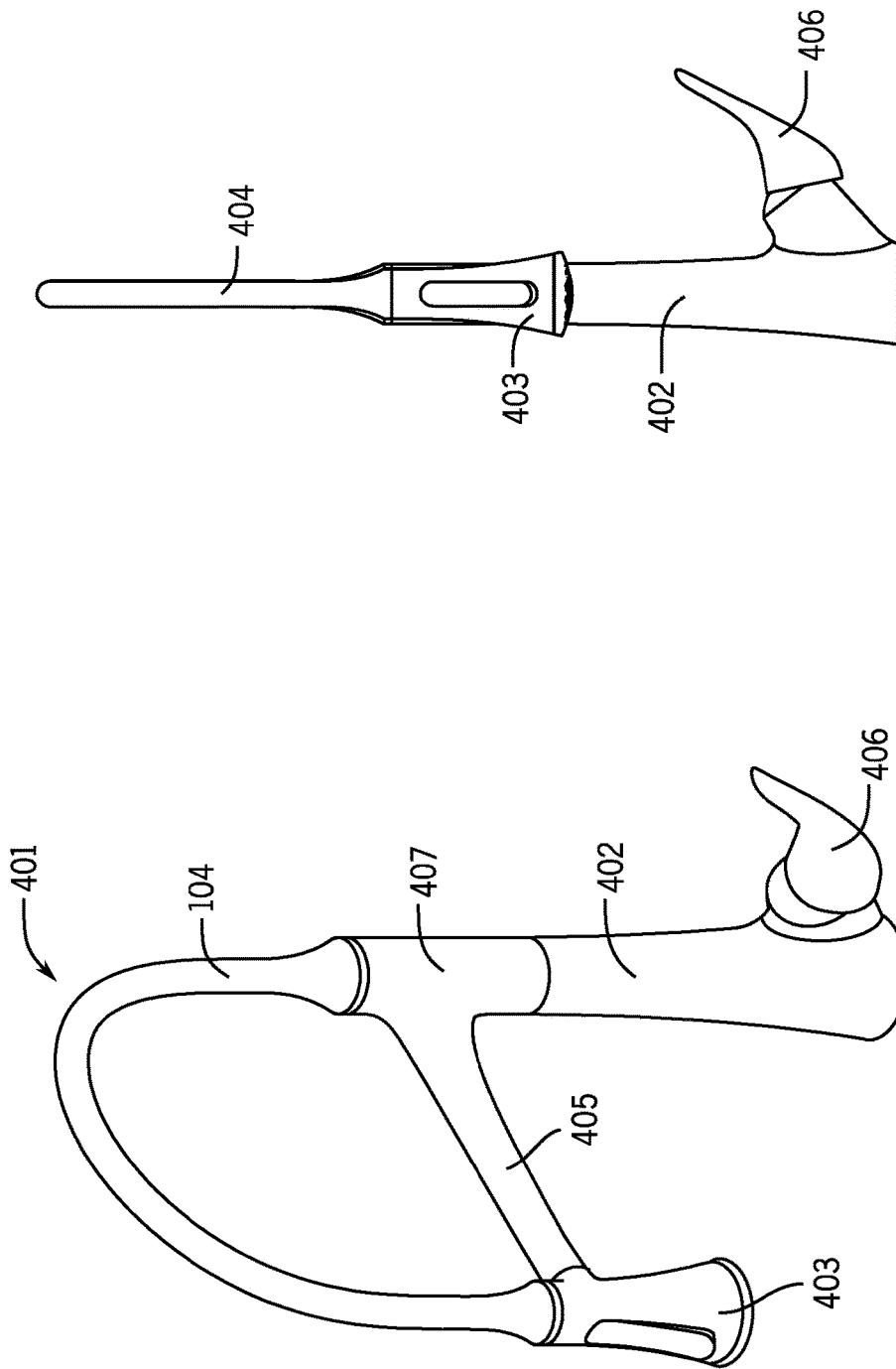

FIG. 16

FIG. 15

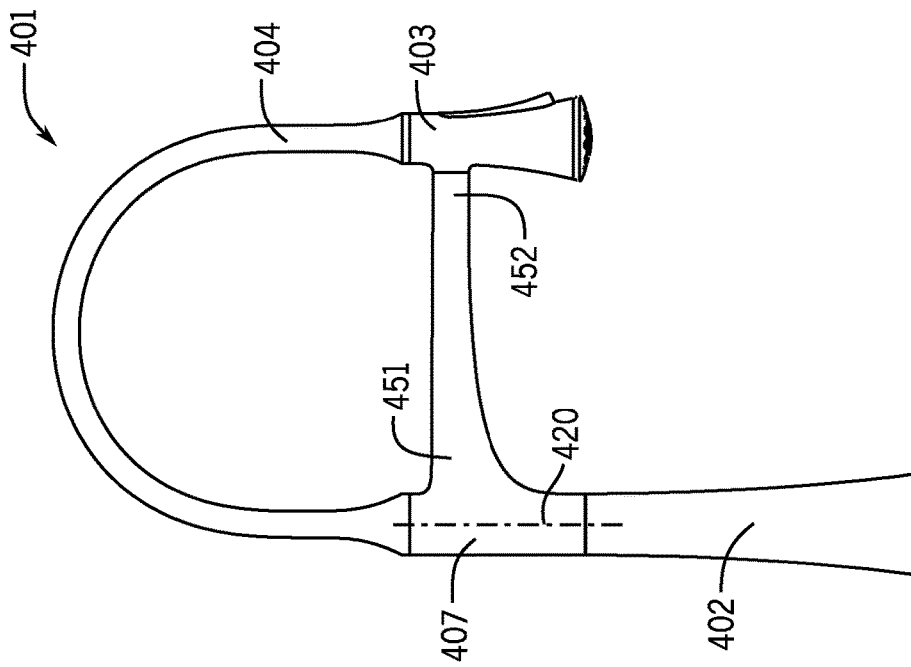

FIG. 17

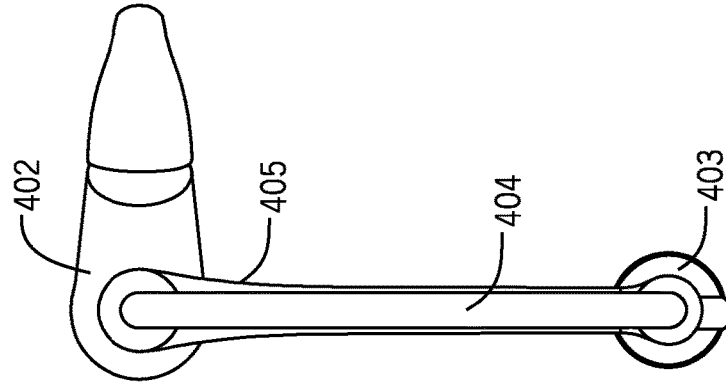

FIG. 18

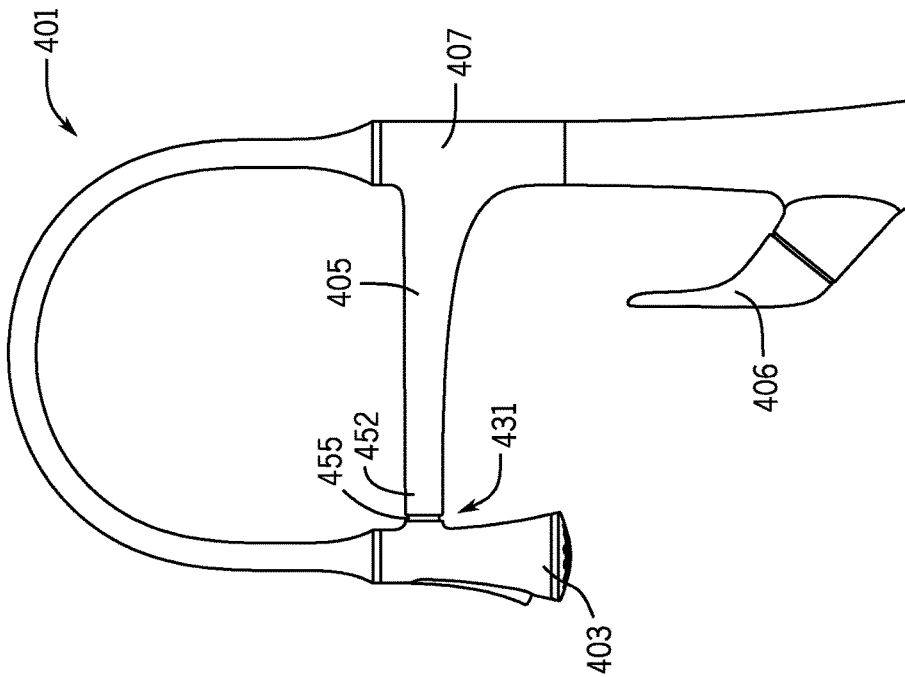

FIG. 19

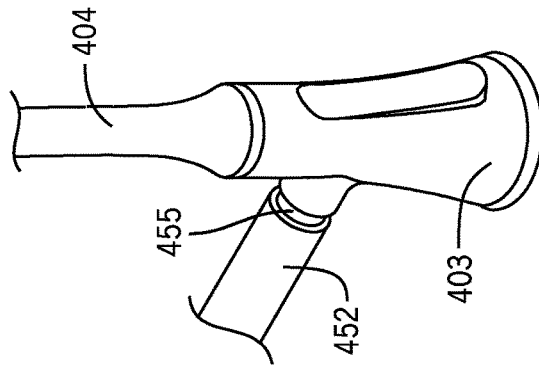

FIG. 20

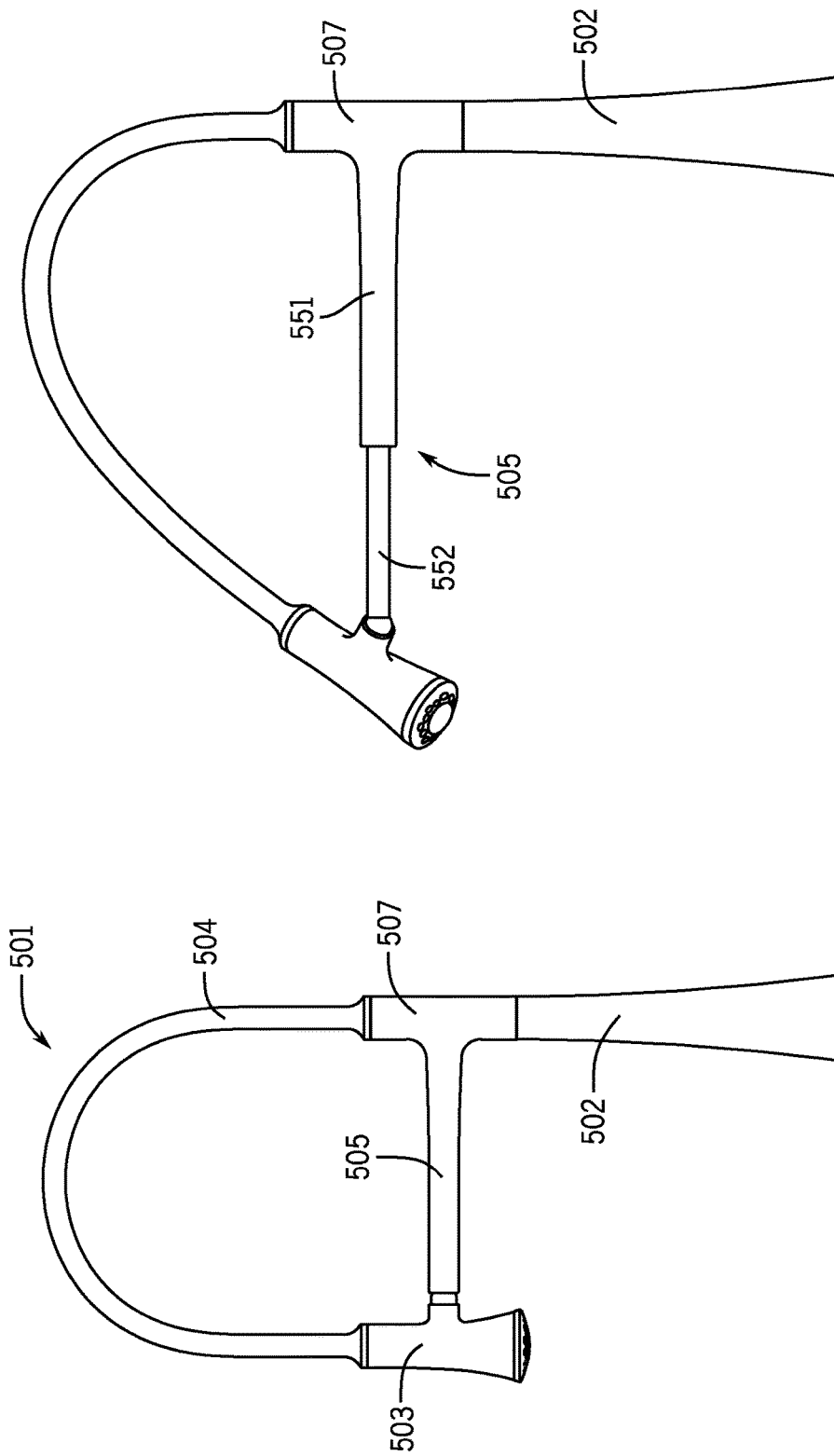

FIG. 22

FIG. 21

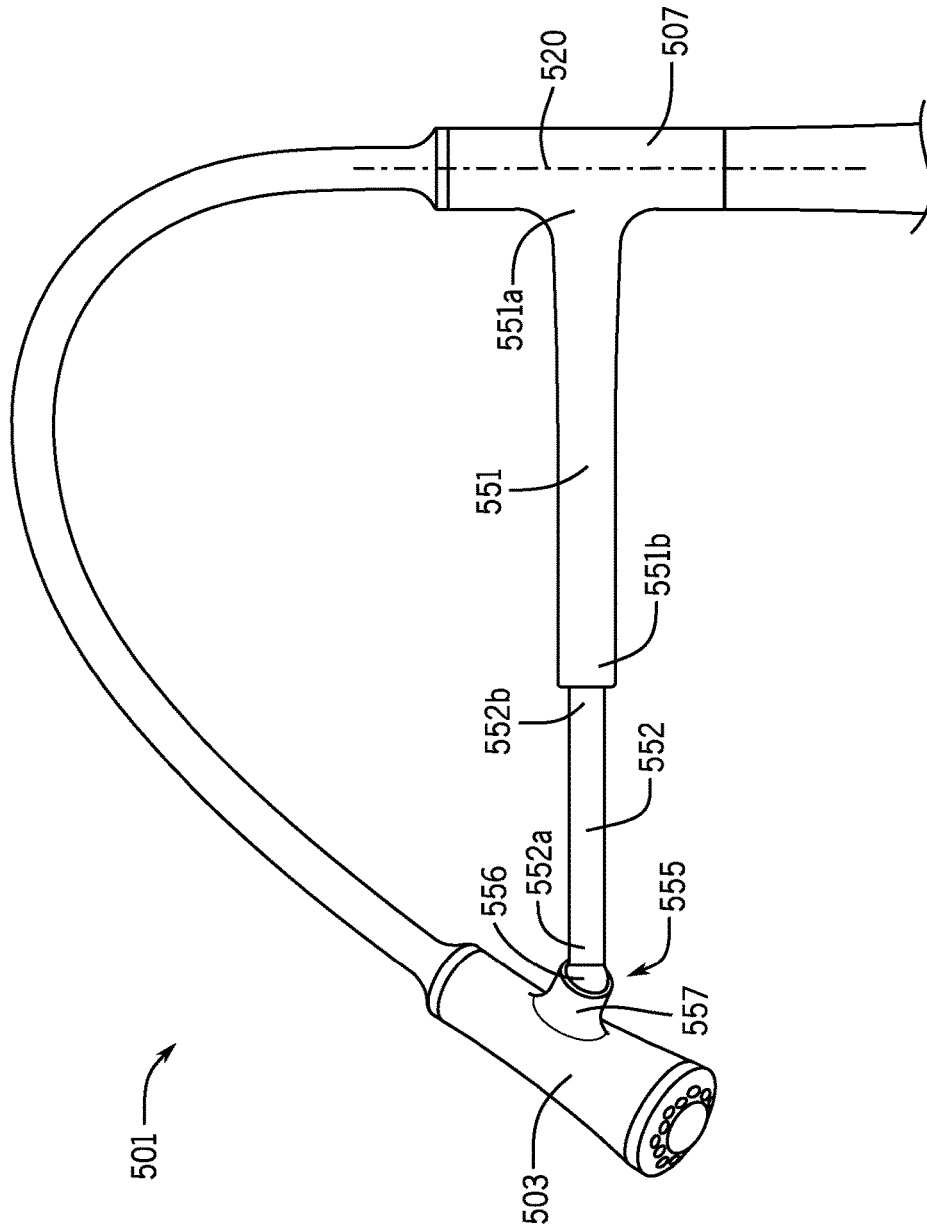

FIG. 23

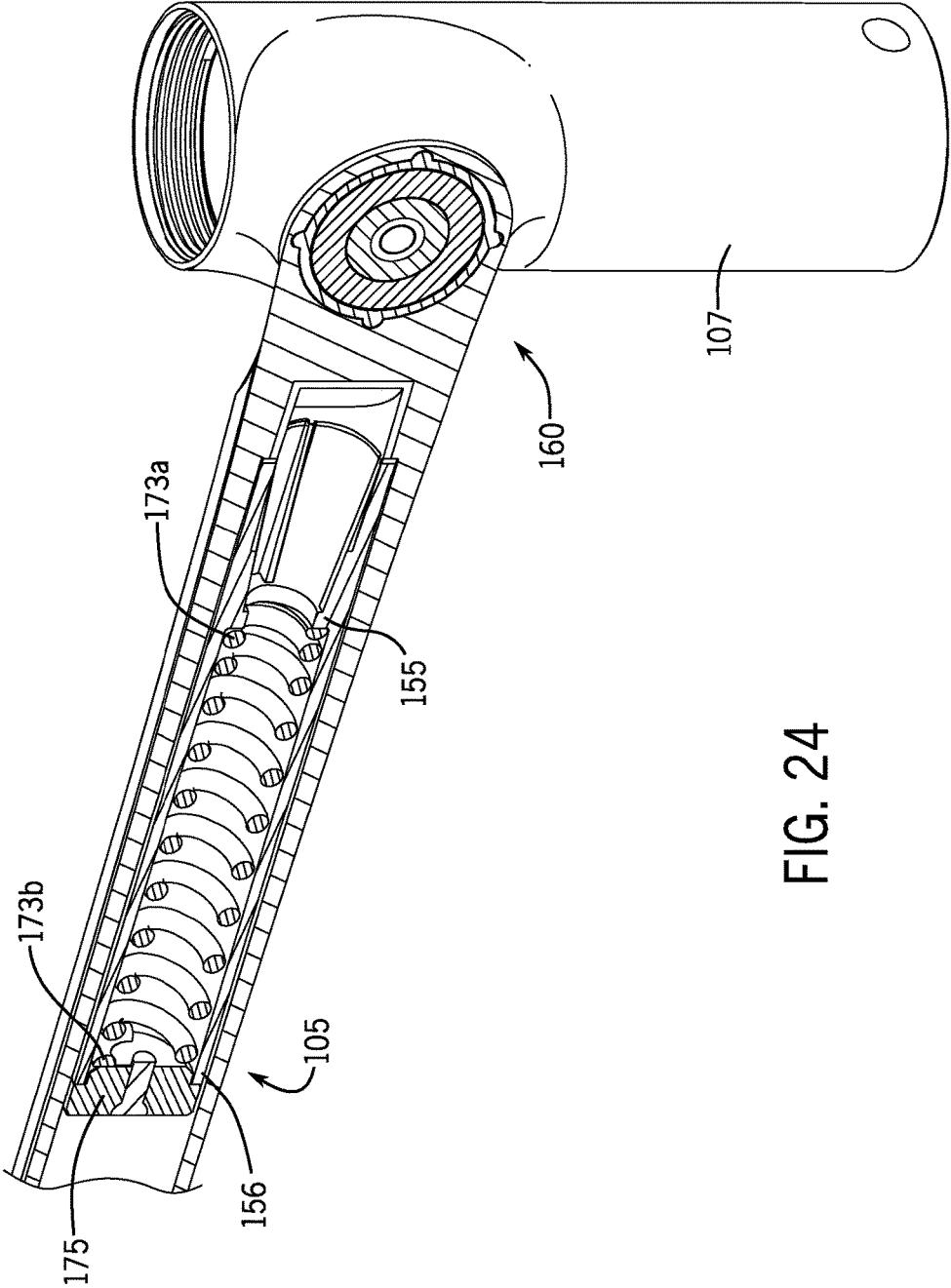

FIG. 24

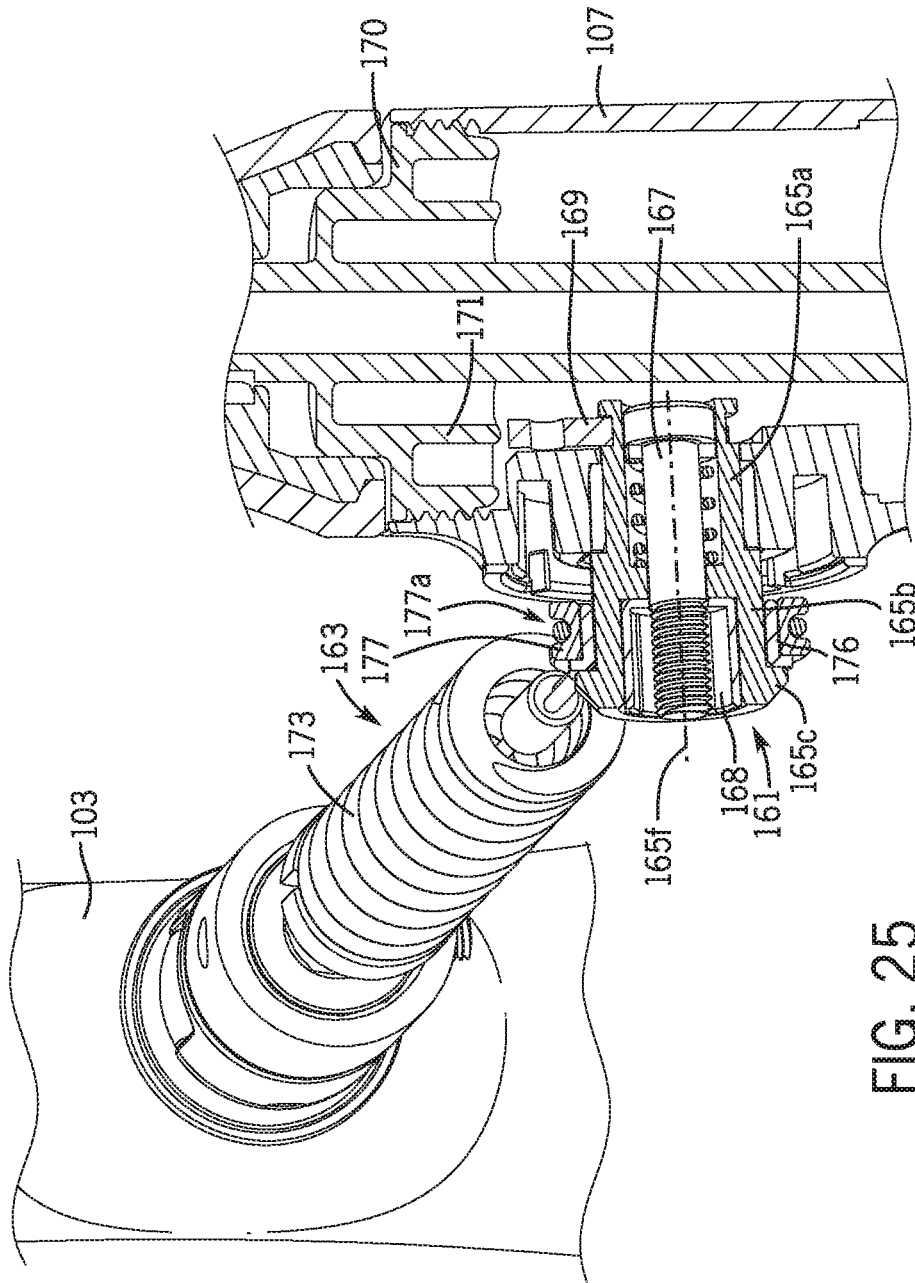

FIG. 25

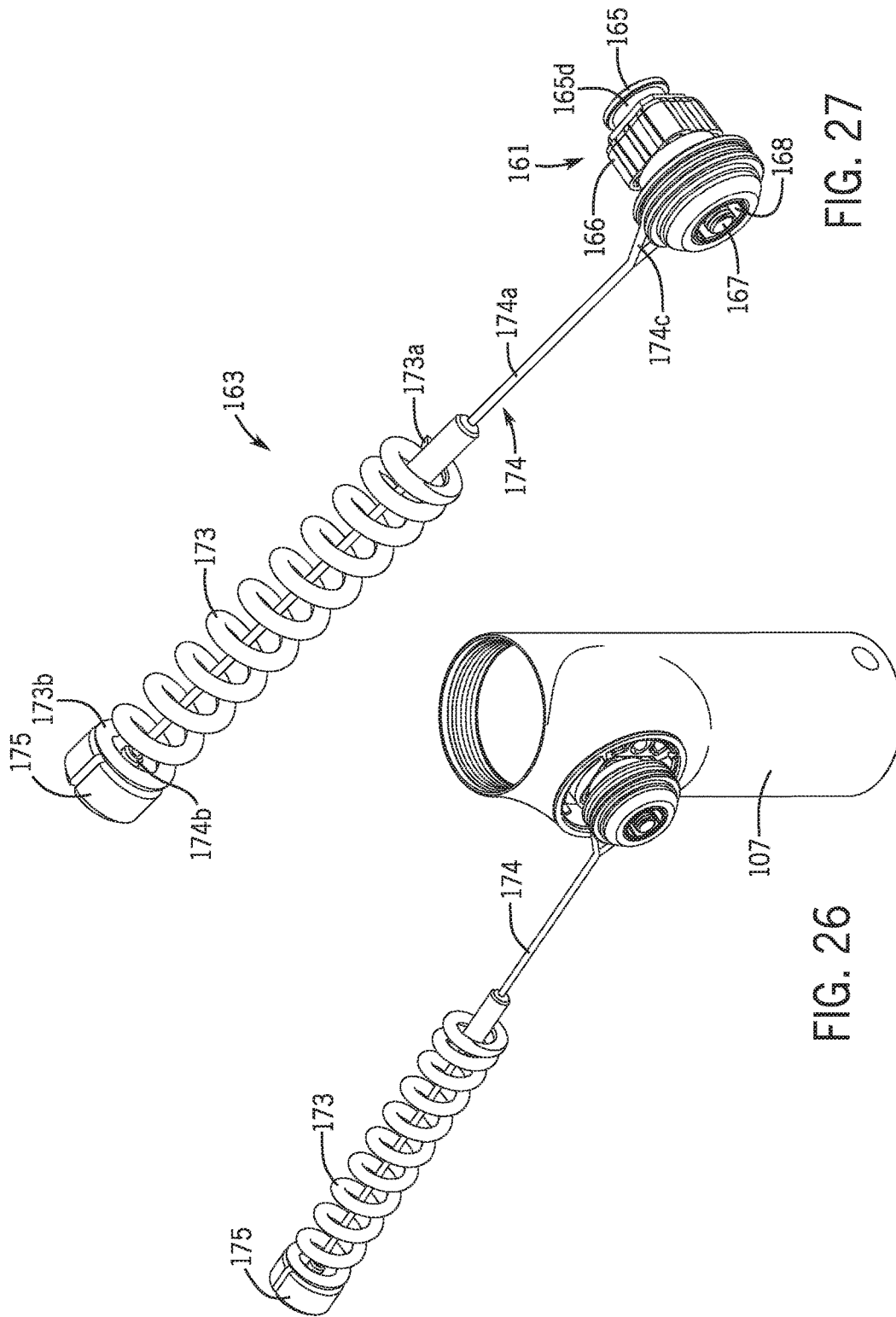

FIG. 27

FIG. 26

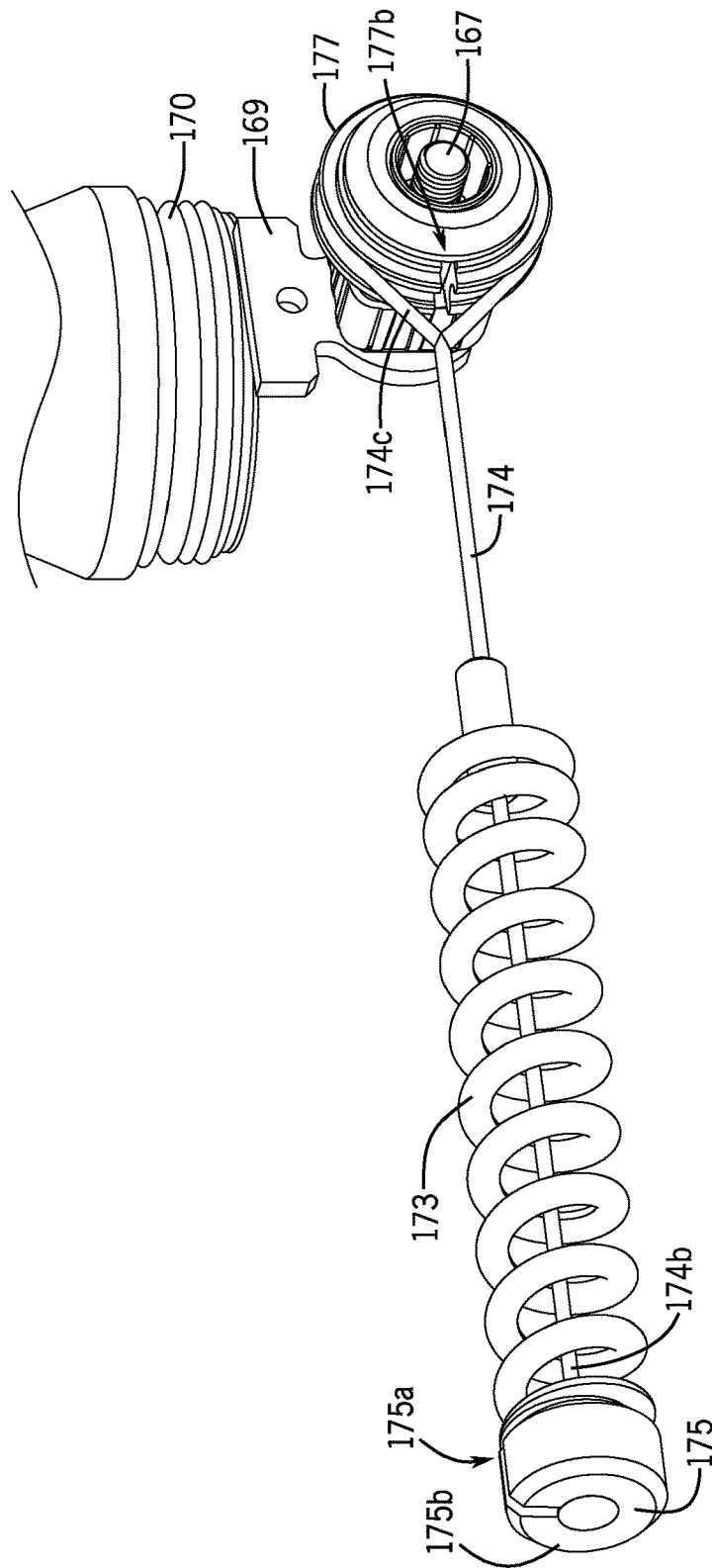

FIG. 28

FAUCET INCLUDING CONTROL ARM**CROSS-REFERENCE TO RELATED APPLICATIONS**

The present application claims priority to and the benefits of U.S. Provisional Patent Application No. 62/345,372, filed on Jun. 3, 2016, which is incorporated by reference herein in its entirety.

BACKGROUND

The present application relates generally to the field of faucets for dispensing water. More specifically, this application relates to faucets having control arms interconnecting movable sprayheads to bases of the spout.

SUMMARY

At least one embodiment of the present application relates to a faucet that includes a base, a sprayhead, a flexible hose, and a control arm. The base is mountable to a mounting surface. The sprayhead is movable relative to the base and is configured to emit water in at least one spray pattern. The flexible hose is separate from and outside of the control arm, and the flexible hose connects the sprayhead and the base. The control arm includes a first end and a second end, wherein the first end is pivotally connected to the base to allow rotation of the control arm relative to the base, and wherein the second end is detachably coupled to the sprayhead such that in a docked position, movement of the control arm moves the sprayhead relative to the base, and such that in a detached position, the sprayhead is movable relative to the base and the control arm.

One of the second end of the control arm and the sprayhead may include a magnet that applies a magnetic force to attract the other of the second end and the sprayhead to couple the second end and the sprayhead together in the docked position.

One of the second end of the control arm and the sprayhead may include a ball and the other of the second end and the sprayhead may include a socket, wherein the socket receives the ball in the docked position to detachably couple the sprayhead and the control arm together. For example, the second end of the control arm may include the socket, the sprayhead may include the ball, one of the ball and the socket may include the magnet and the other of the ball and the socket may include a ferromagnetic material. For example, the second end of the control arm may include the ball and the sprayhead may include the socket.

The faucet may include a collar. The collar may be disposed on an end of the base, such as an end that is opposite a mounting end of the base. The collar may be rotatable relative to the base about a longitudinal axis of the base. A first end of the control arm may be coupled to the collar. For example, the first end of the control arm may be pivotally coupled to the base through the collar such that the control arm rotates relative to the collar and the base about a pivot axis that is transverse to the longitudinal axis.

The faucet may include a retainer that is configured to maintain a position (e.g., a rotational position) of the control arm relative to the base, such as following movement (e.g., rotation) of the control arm relative to the base. By way of non-limiting example, the retainer may include at least one of a spring, a detent, or a ratchet. For example, the retainer may include a bushing assembly and a tension member. The bushing assembly may be configured to rotatably connect

the control arm to the collar. The bushing assembly may include a shaft having an inner shoulder and an outer shoulder, where the inner shoulder is coupled to the collar through an aperture thereof, and the outer shoulder is coupled to the control arm through an aperture thereof. The tension member may be disposed at least in part within the control arm. The tension member may include a first end and a second end, where the first end is coupled to the control arm, and the second end is coupled to the shaft such that the tension member can rotate freely relative to the shaft during rotation of the control arm relative to the collar.

The control arm may be configured to include a first arm portion, which has the first end of the control arm, and a second arm portion, which has the second end of the control arm. The first and second arm portions may be telescopically adjustable relative to one another. For example, at least one of the first and second arm portions may include a hollow section such that the other of the first and second arm portions slides within the hollow section during telescopic adjustment.

At least one embodiment of the present application relates to a faucet that includes a base, a sprayhead, a flexible hose, and a control arm. The base may be configured to mount to a mounting surface. The sprayhead is movable relative to the base and is configured to emit water in at least one spray pattern. The flexible hose is separate from and outside of the control arm, and the flexible hose connects the sprayhead and the base. The control arm includes a first arm and a second arm. The first arm has a first end that is pivotally connected to the base to allow rotation of the first arm relative to the base. The second arm has a first end coupled to the sprayhead, and a second end of the first arm and a second end of the second arm are telescopically connected together to adjust a length of the control arm.

The first end of the second arm may be coupled to the sprayhead through a ball joint. The ball joint may include a ball and a socket, such as where the second arm includes one of the ball and the socket, and the sprayhead includes the other of the ball and the socket. For example, the sprayhead may include an outer housing and a socket, and the socket may include a hollow cylindrical projection extending from a side of the outer housing, where the projection receives the ball of the first end of the second arm.

The faucet may include a collar disposed on an end of the base that is opposite a mounting end of the base. The collar may be rotatable relative to the base about a longitudinal axis. The first end of the first arm may be pivotally connected to the base through the collar such that the first arm is rotatable relative to the collar about a pivot axis that is transverse to the longitudinal axis.

The first end of the second arm may be configured to detachably couple to the sprayhead through a magnet and a ferromagnet, such that in a docked position, movement of the second arm moves the sprayhead relative to the base, and such that in a detached position, the sprayhead is movable relative to the base and the control arm.

At least one embodiment of the present application relates to a faucet that includes a base, a collar, a sprayhead, a control arm, and a flexible hose. The base is configured to mount to a mounting surface. The collar is rotatably coupled to the base such that the collar is rotatable about a rotational axis relative to the base. The sprayhead is movable relative to the base and the collar, where the sprayhead is configured to emit water in at least one spray pattern. The control arm is coupled to the collar through a first spheroidal joint to allow free rotation of the control arm relative to the collar, and the control arm is coupled to the sprayhead through a second

spheroidal joint to allow free rotation of the sprayhead relative to the control arm. The flexible hose connects an inlet of the sprayhead and an outlet of the collar. The flexible hose is also separate from and outside of the control arm.

Each of the first and second spheroidal joints may, for example, include a ball and a socket. The control arm may include the ball of the first spheroidal joint that is coupled to one end of the control arm and may also include the ball of the second spheroidal joint that is coupled to an opposite end of the control arm. The collar may include an outer wall and the socket of the first spheroidal joint, which includes a first hollow cylindrical projection extending from the outer wall. The sprayhead may include an outer housing and the socket of the second spheroidal joint, which includes a second hollow cylindrical projection extending from the outer housing.

The control arm may include a first arm and a second arm. The first arm may include a first end that is coupled to the first spheroidal joint; and the second arm may include a first end that is coupled to the second spheroidal joint. A second end of the first arm and a second end of the second arm may be telescopically connected together to adjust a length of the control arm. One of the first and second arms may include a bore that receives at least a portion of the other of the first and second arms in a shortened position.

BRIEF DESCRIPTION OF THE DRAWINGS

FIG. 1 is a perspective view of an exemplary embodiment of a faucet having a pivoting control arm.

FIG. 2 is a front view of the faucet shown in FIG. 1.

FIG. 3 is a side view of the faucet shown in FIG. 1.

FIG. 4 is a top view of the faucet shown in FIG. 1.

FIG. 5 is another side view of the faucet shown in FIG. 1 with the sprayhead detached from the control arm.

FIG. 6 is a detail view of a portion of the faucet shown in FIG. 1.

FIG. 7 is yet another side view of the faucet shown in FIG. 1 with the sprayhead detached from the control arm.

FIG. 8 is a side view of the faucet shown in FIG. 1 showing a general range of movement of the sprayhead and control arm with the sprayhead and control coupled together.

FIG. 9 is a side view of another exemplary embodiment of a faucet having a pivoting control arm.

FIG. 10 is a side view of the faucet shown in FIG. 9 with the control arm in an extended position.

FIG. 11 is a detail view of a portion of the faucet shown in FIG. 10.

FIG. 12 is a side view of an exemplary embodiment of a faucet having a double jointed control arm.

FIG. 13 is another side view of the faucet shown in FIG. 12 with the control arm in an extended position.

FIG. 14 is a detail view of a portion of the faucet shown in FIG. 13.

FIG. 15 is a perspective view of an exemplary embodiment of a faucet having a swing style control arm.

FIG. 16 is a front view of the faucet shown in FIG. 15.

FIG. 17 is a side view of the faucet shown in FIG. 15.

FIG. 18 is a top view of the faucet shown in FIG. 15.

FIG. 19 is another side view of the faucet shown in FIG. 15 with the sprayhead detached from the control arm.

FIG. 20 is a detail view of a portion of the faucet shown in FIG. 15.

FIG. 21 is a side view of another exemplary embodiment of a faucet having a swing style control arm.

FIG. 22 is another side view of the faucet shown in FIG. 21 with the control arm in an extended position.

FIG. 23 is a detail view of a portion of the faucet shown in FIG. 22.

FIG. 24 is a perspective partial cutaway view of a control arm including a retainer and pivot assembly rotatably coupled to a collar.

FIG. 25 is another perspective partial cutaway view of the control arm, retainer and pivot assembly, and collar shown in FIG. 24.

FIG. 26 is a perspective view of the collar and the retainer and pivot assembly shown in FIG. 24 with the control arm removed for clarity.

FIG. 27 is a perspective view of the retainer and pivot assembly shown in FIG. 24.

FIG. 28 is another perspective view of the retainer and pivot assembly shown in FIG. 24.

DETAILED DESCRIPTION

Referring generally to the Figures, disclosed herein are various embodiments of faucets that include control arms that provide for added control over movement of a sprayhead relative to a base of the spout. The control arms are configured to interconnect (e.g., detachably, fixedly, etc.) movable sprayheads to the bases to support forces/loads from the sprayheads while providing an increased range of coverage of the sprayhead. The control arms may be adjustable (e.g., telescopically) or may have a fixed length. The control arms may be configured to swing, to pivot, or to provide other movements. The control arms may include joints (e.g., ball joints) to provide additional movement and control.

FIGS. 1-8 illustrate an exemplary embodiment of a faucet 101 having a pivoting control arm. The faucet 101 includes a base 102 (e.g., spout base), a sprayhead 103, a flexible hose 104 connecting (e.g., physically, fluidly) the sprayhead 103 and the base 102, and a control arm 105. As discussed in more detail below, the control arm 105 may advantageously help control the movement of the sprayhead 103 when coupled (e.g., docked, attached, etc.) to the control arm 105, support the forces (e.g., weight) from the sprayhead 103, as well as provide other advantages.

The base 102 is configured to be fixedly mounted (e.g., secured, attached, etc.) to a mounting surface, such as a sink, countertop or other suitable surface. The base 102 is hollow such that other elements of the faucet 101 can be routed or housed within the base 102. For example, the base 102 may house a valve, one or more water delivery lines (e.g., conduits, etc.) for carrying water, or other elements of the faucet.

The faucet 101 includes a valve for controlling flow of water therethrough. For example, the faucet 101 may include a mixing valve that controls a flow of hot water, cold water, or a mixture of hot and cold waters through the base 102 and the hose 104 to the sprayhead 103. According to another example, the valve may control the flow of water from a single source through the faucet 101. Any type of valve may be employed with the faucets of this application. The valve may be located anywhere in the faucet 101 (e.g., within the base 102) or external to the faucet 101 (e.g., below the base 102) and fluidly connected thereto.

The faucet 101 may include a handle for controlling operation of a valve. As shown in FIG. 1, the handle 106 is moveably mounted to the base 102 to control operation of the faucet, such as by controlling operation of a valve. The handle 106 can be moved relative to the base 102 to adjust, for example, the flow rate and/or the temperature of water emitted from the sprayhead 103 of the faucet 101. The

handle **106** can have any suitable configuration (e.g., shape, location, etc.). According to other examples, the faucet may include more than one handle or no handles at all, such as if the faucet includes sensing technology to control operation of the faucet.

The sprayhead **103** is configured to be moveable relative to the base **102** of the faucet and to emit water in one or more spray patterns. The sprayhead **103** can be configured according to any suitable configuration. By way of non-limiting examples, the sprayhead **103** can be configured similar to (e.g., having the same or similar structure and configuration, except where noted otherwise) the sprayheads disclosed in U.S. patent application Ser. No. 14/547,913 (filed on Nov. 19, 2014); U.S. patent application Ser. No. 14/207,244 (filed on Mar. 12, 2014); and/or U.S. patent application Ser. No. 13/359,089 (filed on Jan. 26, 2012), which are incorporated by reference herein in their entireties. It is noted that other sprayheads can be employed with the faucets of this application and the sprayheads disclosed in the above identified applications are intended as examples.

As shown in FIGS. 2 and 3, the sprayhead **103** includes a body **130** extending between an inlet end **131** and an outlet end **132**. The inlet end **131** is connected to the flexible hose **104** and the outlet end **132** includes a sprayface containing a nozzle or a plurality of nozzles. The sprayhead **103** includes one or more actuators for controlling operation of the sprayhead **103**. As shown, the sprayhead **103** includes an actuator **133** that is configured to control operation of the sprayhead **103**. According to one example, the actuator **133** is a soft touch spray button including silicone over (e.g., overmolded onto) a flexible substrate. As discussed in more detail below, the sprayhead **103** also includes a docking feature for coupling to (and decoupling from) the control arm **105**.

The flexible hose **104** is configured to physically and fluidly connect the base **102** and the sprayhead **103**. The hose **104** is flexible to allow the sprayhead **103** to be moved (e.g., articulated, etc.) relative to the fixed base **102**, such as to redirect the spray from the sprayhead **103**. According to one non-limiting example, the hose **104** includes a sheathing surrounding a fluid conduit. The fluid conduit is configured to allow fluid (e.g., water) to flow therethrough, such as to fluidly connect the base **102** and the sprayhead **103**. The sheathing is configured to protect the fluid conduit to prevent or reduce the likelihood of damage to the conduit. The sheathing includes a first material (e.g., silicone), which according to one example is overmolded onto the fluid conduit, which includes a second material (e.g., polymer) that is pliable. According to one example, the hose is pliable enough to support its own weight, without causing the sprayhead **103** to move when repositioned.

The hose **104** includes a first end **141** and a second end **142**. As shown in FIG. 3, the first end **141** is coupled to the base **102** (either directly or indirectly through an intervening member, such as an element of the control arm, the collar, etc.) and the second end **142** is coupled to the sprayhead **103** (either directly or indirectly through an intervening member).

The control arm **105** is configured to support the sprayhead **103** by transferring loads back to base **102** while allowing for movement of the sprayhead **103** relative to the base **102**. As shown in FIGS. 1-8, the control arm **105** includes an arm **150** having a first end **151** and a second end **152**.

The first end **151** of the arm **150** is pivotally connected to a collar **107** (see FIGS. 3 and 5), which can be part of the base **102** or part of the control arm **105** of the faucet **101**,

through a pivot mechanism such that the arm **150** can rotate (e.g., pivot) relative to the base **102** and the collar **107**, such as in a generally vertically extending plane. For example, the arm **150** may include a stud (e.g., post) that pivotally engages a bearing in the collar **107**. Alternatively, the collar **107** may include a stud that engages a bearing in the arm **150**. This arrangement advantageously allows for the arm **150** to support loads from the sprayhead **103** when the sprayhead **103** is in different positions. Illustrating this point, FIG. 8 shows the arm **150** in various positions (e.g., a first horizontal position of the arm **150**, a second elevated position of the arm **150'**, and a third lowered position of the arm **150''**) and supporting the sprayhead **103**, **103'**, **103''** docked to the second end **152**, **152'**, **152''** of the respective arm.

The collar **107** may be fixed relative to the base **102**. For example, the collar **107** may be integrally formed with the base **102**. As shown in FIGS. 1-8, the collar **107** is configured to rotate relative to the base **102** about a longitudinal axis **120** (e.g., a substantially vertical axis) of the base and/or collar. This arrangement allows the arm **105** to swing relative to the base **102** with the rotating collar **107**. For example, when the control arm **105** is in the horizontal position, the control arm **105** rotates with the collar **107** in a generally horizontal plane. The base **102** may be configured to rotationally support the collar **107**.

The second end **152** of the control arm **105** is configured to be coupled to the sprayhead **103** to support loads therefrom. As shown, the second end **152** is configured to detachably couple to the sprayhead **103** to support the sprayhead **103** when docked together and to further allow the sprayhead **103** to be moved independently of the control arm **150** when the sprayhead **103** is detached from the second end **152**. This arrangement provides additional utility, such as allowing a greater reach by the sprayhead **103**. By way of example, FIGS. 5 and 7 show the sprayhead **103** detached from the arm **150**.

The faucet **101** may include a docking feature to allow the sprayhead **103** to be docked to and detached from the arm **150**. According to one exemplary embodiment, the docking feature includes a ball and a socket that detachably receives the ball. As shown in FIG. 5, the second end **152** of the arm **150** includes a socket (e.g., cup, concave recess, etc.) and the sprayhead **103** includes a ball **135** (e.g., a generally or partially spherical element) that is configured to engage the socket in the second end **152**. As shown in FIG. 7, the second end **152** of the arm **150** includes a ball, and the sprayhead **103** includes a socket that receives the ball.

The docking feature may be magnetized (e.g., employ a magnet) to apply a force (e.g., magnetic force) to retain the ball and socket when coupled together. For example, one of the ball and the socket may include a magnet or be magnetic and the other of the ball and the socket may include a ferromagnetic portion or be ferromagnetic, such that a magnetic force attracts the ball and socket to one another. The magnetic force can be tailored to the application, such as, for example, the magnetic force can be stronger for faucets having relatively higher weight sprayheads and/or hoses, whereas the magnetic force can be weaker for faucets having relatively lower weight sprayheads and/or hoses. The detachable docking feature (e.g., utilizing a magnetic socket and ball) advantageously allows for a user to move (e.g., rotate) the sprayhead independently from the arm.

The arm (e.g., the arm **150**) having a joint may be configured to stay in place when moved to a new position, such as by overcoming the weight of the sprayhead and the hose. A feature, such as a detent, a spring, or other suitable element, may be employed to bring and/or retain the arm in

a “home” position (e.g., level with horizontal), while allowing the arm to be raised and lowered when only a moderate force is applied to the arm. Thus, the joint may be configured to resist moving when set in a position, rather than springing back to a set position (e.g., the “home” position, the previous position, etc.).

According to other examples, the control arms of the faucets may have other configurations. By way of example, the control arms may be configured as pivoting control arms that are fixedly connected to the sprayheads, as pivoting arms that are extendible, as double jointed arms, as swing style arms, or as other suitable arms.

FIGS. 9-11 illustrate another exemplary embodiment of a faucet **201** having a pivoting control arm **205** that is extendible in length. The faucet **201** includes a base **202** that is configured the same as the base **102** (e.g., having a rotating collar **207** to allow rotation of the control arm **205** and collar **207** relative to the base **202**), a hose **204** that is configured the same as the hose **104**, and a sprayhead **203** that is configured the same as the sprayhead **103**, except where noted otherwise.

The control arm **205** includes a plurality of arms that are moveable relative to one another to allow for the length of the control arm **205** to be increased (e.g., in an extended position) or decreased (e.g., in a retracted position). As shown best in FIGS. **10** and **11**, the control arm **205** of the faucet **201** includes a first arm **251** and a second arm **252** that are configured to move telescopically relative to one another. However, it is noted that the faucets disclosed herein may be configured having a telescopic control arm having more than two arms, such as to provide for a broader range of motion of the control arm.

The first arm **251** of the control arm **205** has a first end **251a** that is pivotally coupled to the collar **207** (to allow the control arm **205** to be rotated in a plane of rotation that is substantially orthogonal to the plane of rotation of the collar **207**) and a second end **251b** that is telescopically connected to the second arm **252**. For example, a first end of the control arm **205** (e.g., a first end of the first arm **251**) may be pivotally coupled to the base **202** through the collar **207**, such that the control arm **205** rotates relative to the collar **207** and the base **202** about a pivot axis **221** that is transverse (e.g., orthogonal) to a longitudinal axis **220**. As shown, the first arm **251** is a hollow member such that the second arm **252** (or at least a portion thereof) can be moved into and out of a bore in the first arm **251** to provide the telescoping movement. Alternatively, the second arm **252** may be configured having a bore that receives at least a portion of the first arm **251** to provide the telescoping movement.

The second arm **252** of the control arm **205** has a first end **252a** coupled to the sprayhead **203** and a second end **252b** that is telescopically connected to the first arm **251**. As shown, the first end of the second arm **252** is coupled to the sprayhead **203** with a spheroidal joint, such as a ball joint **255** that includes a ball and a socket. As shown best in FIG. **11**, the ball is part of the first end **252a** of the second arm **252** and the socket is part of the sprayhead **203**. For example, the sprayhead may include an outer housing and the socket, and the socket may include a hollow cylindrical projection extending from a side of the outer housing. Accordingly, the projection receives the ball of the first end of the second arm. However, according to another example, the ball is part of the sprayhead **203** and the socket is part of the second arm **252**. The ball joint **255** can be magnetized to allow for the sprayhead **203** to be detached from the control arm **205**, or the ball joint **255** can be configured not to detach the ball and the socket to rotatably secure the control arm to the spray-

head. Thus, the control arm **205** may be configured to be permanently or detachably connected to the sprayhead **203**, such as through the ball joint **255**.

As shown, the first and second arms **251**, **252** can be telescopically adjusted to shorten or lengthen the distance between the first end **252a** of the second arm **252** and the first end **251a** of the first arm **251**, which in turn increases or decreases the distance between the sprayhead **203** and the base **202**. The force necessary to adjust the first and second arms **251**, **252** telescopically can be tailored to specific applications.

FIGS. **12-14** illustrate another exemplary embodiment of a faucet **301** having a double jointed adjustable control arm. The faucet **301** includes a base **302** that is configured the same as the base **102** (e.g., having a rotating collar to allow rotation of the control arm **305** and collar relative to the base **302**), a flexible hose **304** that is configured the same as the hose **104**, and a sprayhead **303** that is configured the same as the sprayhead **103**, except where noted otherwise.

The control arm **305** includes two or more arms that are moveable relative to one another to allow for the length of the control arm **305** to be increased or decreased by extending or retracting the arms. As shown best in FIGS. **13** and **14**, the control arm **305** of the faucet **301** includes a first arm **351** and a second arm **352** that are configured to move telescopically relative to one another. As shown, the first and second arms **351**, **352** move in a linear direction along a longitudinal axis of the arms. However, it is noted that the faucets disclosed herein may be configured having a telescopic control arm having two or more arms that are curved or have another suitable shape and still provide the relative motion to extend/retract the control arm.

The first arm **351** of the control arm **305** has a first end that is coupled to the collar **307** with a first ball joint **355** (e.g., primary ball joint) to allow the control arm **305** to be rotated relative to the collar **307**. The ball joint **355** includes a ball and a socket, with one of the ball and the socket being coupled to the first end of the first arm **351** and the other of the ball and the socket being coupled to the collar **307**. The ball and socket of the first ball joint **355** may be permanently coupled together or may be separable, such as by using a magnetized ball joint.

The first arm **351** also includes a second end that is telescopically connected to the second arm **352**. As shown, the first arm **351** is a hollow member such that the second arm **352** (or at least a portion thereof) can be inserted into and withdrawn from a bore in the first arm **351** to provide the telescoping movement. Alternatively, the second arm **352** may be configured having a bore that receives at least a portion of the first arm **351** to provide the telescoping movement.

The second arm **352** of the control arm **305** has a first end coupled to the sprayhead **303** and a second end that is telescopically connected to the first arm **351**. As shown, the first end of the second arm **352** is coupled to the sprayhead **303** with a second ball joint **356** that includes a ball and a socket. As shown best in FIG. **14**, the ball is part of the first end of the second arm **352** and the socket is part of the sprayhead **303**. However, the ball may be configured as part of the sprayhead **303** and the socket may be configured as part of the second arm **352**. The second ball joint **356** can be magnetized to allow for the sprayhead to be detached from the control arm, or the ball and socket of the second ball joint **356** can be configured permanently coupled. Thus, the control arm **305** may be configured to be permanently or detachably connected to the sprayhead **303**.

As shown and described, the first and second arms **351**, **352** of the control arm **305** can be telescopically adjusted to shorten or lengthen the distance between the first end of the second arm **352** and the first end of the first arm **351** to in turn increase or decrease the distance between the sprayhead **303** and the base **302**. The force necessary to adjust the first and second arms **351**, **352** telescopically can be tailored to specific applications.

The control arm **305** (as well as any other adjustable control arm disclosed in this application) may be configured with a locking feature that can selectively lock the first and second arms **351**, **352** in a position (e.g., an extended position, a retracted position, etc.). The locking feature may lock the arms of the control arm **305** in a set number of positions or may lock the arms in any relative arrangement.

FIGS. 15-20 illustrate another exemplary embodiment of a faucet **401** having a swing style control arm. The faucet **401** includes a base **402** that is configured the same as the base **102**, a flexible hose **404** that is configured the same as the hose **104**, and a sprayhead **403** that is configured the same as the sprayhead **103**, except where noted otherwise.

The faucet **401** may include a handle for controlling an operation of faucet **401**. As shown in FIGS. 15 and 16, a single handle **406** is moveably mounted to the base **402** to control operation of the faucet, such as by controlling operation of a valve that supplies the sprayhead **403** with water. The handle **406** can be moved relative to the base **402** to adjust the flow rate and/or the temperature of water emitted from the sprayhead **403** of the faucet **401**. It is noted that the faucet **401** may include more than one handle or no handles at all, such as if the faucet includes sensing (e.g., touchless) technology to control operation of the faucet.

As shown in FIGS. 15-20, the collar **407** and the control arm **405** are integrally formed as a unitary (e.g., single, non-separable) element. According to other examples, the control arm **405** and the collar **407** are formed separately then coupled together such that they operate/function together as one element (e.g., are fixedly coupled together).

The collar **407** of the faucet **401** is rotatably coupled to an end (shown as the top end) of the base **402**. For example, the collar **407** may be configured as a sleeve (e.g., a generally cylindrical element) that fits over a supporting element (e.g., a support sleeve, a bearing, etc.) of the base **402** to support rotation of the collar **407** relative to the base **402**.

The control arm **405** of the faucet **401** is fixed relative to the collar **407** such that rotation of the collar **407** rotates the control arm **405** by the same amount (e.g., the same angular rotation about a longitudinal axis **420** of the collar **407**, as shown in FIG. 17). As shown, a first end **451** of the control arm **405** is fixedly connected to (e.g., integrally formed with) the collar **407**. A second end **452** of the control arm **405**, which is opposite the first end, is configured to couple to the sprayhead **403** to support the sprayhead **403**.

As shown best in FIG. 19, the second end **452** of the control arm **405** includes a magnet that is configured to attract (e.g., through a magnetic force) the sprayhead **403** to detachably couple the control arm **405** and the sprayhead **403** through magnetism. The magnet may be an element **455** (e.g., cylindrical element, puck shaped element) disposed in the second end **452**, which may be configured to extend beyond the second end **452** such as to engage a recess **431** in the sprayhead **403** when securing the sprayhead **403** and control arm **405** together. At least a portion (e.g., an extension, a wall, a body, etc.) defining the recess **431** includes a ferromagnetic material that is attracted to the magnet.

According to another example, the sprayhead **403** includes the magnet and the control arm **405** includes a

ferromagnetic connecting feature/element, such as a recess to receive the magnet. It is noted that the magnet and ferromagnetic connecting features may have other configurations and that the examples described herein are not limiting, but are exemplary.

The arrangement of the faucet **401** allows a user of the faucet to move the sprayhead **403** relative to the base **402** in a swinging motion along a circular arc about a rotational axis of the collar **407** (shown in FIG. 17 as the longitudinal axis) when the sprayhead **403** is connected (e.g., docked) to the control arm **405**. When docked, the control arm supports the sprayhead **403** distributing forces (e.g., from its weight) back to the base **402** to make it relatively easy to move and/or maintain the use position of the sprayhead **403**. Also when docked, the sprayhead **403** can be rotated relative to the second end **452** (e.g., in a plane defined by a surface of the second end or the magnet coupled thereto) to align the sprayhead **403** at any angle relative to vertical to provide additional coverage by the spray pattern of the sprayhead **403**.

The arrangement of the faucet **401** also allows a user of the faucet to detach the sprayhead **403** from the control arm **405** such that the sprayhead **403** can reach objects outside of the radius of the arc of the control arm **405**. When detached, the sprayhead **403** can be moved anywhere within a range defined by the flexible hose **404**.

FIGS. 21-23 illustrate yet another exemplary embodiment of a faucet **501** having a swing style control arm **505** that extends/retracts to provide an increased range of coverage by a sprayhead **503** when docked to the control arm **505**. The faucet **501** also includes a collar **507** rotatably supported on a base **502** and a flexible hose **504** connecting the sprayhead **503** and the collar **507**. The base **502** is configured the same as the base **402**, the hose **504** is configured the same as the hose **104**, and the sprayhead **503** is configured the same as the sprayhead **103**, except where noted otherwise.

Like with the faucet **401**, the collar **507** and the control arm **505** of the faucet **501** operate as one element. The collar **507** and the control arm **505** may be integrally formed as a unitary (e.g., single, non-separable) element, or formed separately then coupled together such that they operate/function together as one element. The collar **507** is configured the same as the collar **407**, except where noted otherwise.

The control arm **505** includes two or more arms that are moveable relative to one another to allow for the length of the control arm **505** to be increased and decreased (e.g., to extend and retract the control arm **505**). As shown best in FIGS. 22 and 33, the control arm **505** of the faucet **501** includes a first arm **551** and a second arm **552** that are configured to move (e.g., telescopically) relative to one another to expand/retract the control arm **505** (FIG. 21 shows a retracted position and FIGS. 22 and 23 show an extended position). As shown best in FIG. 23, a first end **551a** of the first arm **551** is fixed relative to the collar **507** such that rotation of the collar **507** rotates the first arm **551** by the same amount (e.g., the same angular rotation about a longitudinal axis **520** of the collar **507** and/or the base **502**). The first end **551a** of the first arm **551** is fixedly connected to (e.g., integrally formed with) the collar **507**. A second end **551b** of the first arm **551**, which is opposite the first end **551a**, is adjustably coupled to the second arm **552**. As shown, the first arm **551** is a hollow member such that the second arm **552** (or at least a portion thereof) can be moved into and out of a bore in the first arm **551** to provide the telescoping movement. Alternatively, the second arm **552**

may be configured having a bore that receives at least a portion of the first arm 551 to provide the telescoping movement.

A first end 552a of the second arm 552 of the control arm 505 is coupled to the sprayhead 503 and a second end 552b of the second arm 552 is telescopically connected to the first arm 551. As shown, the first end 552a of the second arm 552 is coupled to the sprayhead 503 with a ball joint 555. The ball joint 555 includes a ball 556 and a socket 557 that receives the ball 556 and allows for relative movement (e.g., free rotation about the spherical ball) between the ball 556 and the socket 557. The ball 556 is part of the first end 552a of the second arm 552 or the sprayhead 503, and the socket 557 is part of the other of the sprayhead 503 and the first end 552a of the second arm 552. The ball joint 555 can be magnetized to allow for the sprayhead to be detached from the second arm 552, or the ball 556 and the socket 557 may be permanently connected together.

Thus, the first and second arms 551, 552 can be adjusted (e.g., telescopically) to shorten or lengthen the distance between the first end 552a of the second arm 552 and the first end 551a of the first arm 551, which in turn increases or decreases the distance between the sprayhead 503 and the base 502. The ball joint 555 also allows for free rotation of the sprayhead 503 relative to the control arm 505 (e.g., the first end 552a of the second arm 552) to further increase the range of coverage of the sprayhead 503.

FIGS. 24-28 illustrate an exemplary embodiment of a control arm 105 that is rotatably coupled to a collar 107 through a retainer and pivot assembly 160. The retainer and pivot assembly 160 is configured to facilitate rotation of the control arm 105 relative to the collar 107 and further is configured to retain the control arm 105 in the rotational position of the control arm 105 relative to the collar 107. By way of example, the retainer and pivot assembly 160 can retain the control arm in the positions shown by 150, 150' and 150" in FIG. 8, as well as any other position of the control arm 150 in the range of motion of the control arm 150 (e.g., a circular motion along a radius of rotation).

As shown, the retainer and pivot assembly 160 includes a bushing assembly 161 and a tension assembly 163 coupled to the bushing assembly 161 and the control arm 150. The bushing assembly 161 facilitates rotation of the control arm 105 relative to the collar 107, and the tension assembly 163 maintains the rotational position of the control arm 105 relative to the collar 107 by maintaining a threshold friction, as discussed below in more detail.

The bushing assembly 161 includes a shaft 165 having a first shoulder 165a (e.g., inner shoulder) that engages the collar 107, as shown in FIGS. 25 and 26. The first shoulder 165a may be configured to prevent relative rotation between the shaft 165 and one of the control arm 105 and the collar 107. As shown, the first shoulder 165a is square shaped and is received in a complementary hole in the collar 107 to prevent relative rotation between the shaft 165 and the collar 107. As shown in FIG. 27, a bearing 166 is disposed around at least a portion of the first shoulder 165a to seat between a wall of the collar 107 and the first shoulder 165a. The bearing 166 has a shape (e.g., square, splined, polygonal, etc.) that provides anti-rotation between the bearing 166, the shaft 165 and the collar 107.

The shaft 165 also includes a second shoulder 165b (e.g., outer shoulder) that receives and supports part of the tension assembly 163. For example, the second shoulder 165b may support a bearing and/or a split ring, as discussed below in

more detail. Disposed on the second shoulder 165b is a flange 165c for retaining the bearing and/or split ring onto the second shoulder 165b.

The bushing assembly 161 may include a fastener 167 that is configured to couple the control arm 105 to the bushing assembly 161. As shown in FIG. 25, the fastener 167 extends through a bore in the shaft 165, such that threads of the fastener 167 thread to threads of the control arm 105. The shaft 165 may include a radial inwardly extending inner shoulder that is configured to support the fastener 167.

The bushing assembly 161 may include a second bearing 168 that is configured to support rotation of the control arm 105 relative to the shaft 165. As shown in FIG. 25, the second bearing 168 is disposed in a bore in the second shoulder 165b of the shaft 165. By way of example, the control arm 105 may include a post that includes the threads that thread to the fastener 167, where the post may engage the second bearing 168 (e.g., a bore therein).

The bushing assembly 161 may be coupled to the collar 107 using a locking plate 169 that engages a channel 165d (e.g., an undercut/recessed section relative to the adjacent sections) in the first shoulder 165a of the shaft 165 (see FIGS. 25 and 27). The locking plate 169 includes an opening that is shaped to complement the shape of the channel to prevent the shaft 165 from moving along a longitudinal axis 165f of the shaft 165. The locking plate 169 is retained in the collar 107, as shown in FIG. 25, to retain the bushing assembly 161 (and control arm 105, which is not shown in FIG. 25 for clarity) to the collar 107. A cap 170 may be employed to retain the locking plate 169 in a direction transverse to the longitudinal axis 165f. As shown in FIG. 25, the cap 170 includes external threads that thread to mating internal threads of the collar 107 to fix the cap 170 and the collar 107 together. The cap 170 includes a shoulder 171 that maintains the locking plate 169 in place in the transverse direction.

As shown in FIGS. 24-27, the tension assembly 163 includes a spring 173, a cable 174 (e.g., wire, rope, etc.), a plug 175, a bearing 176, and a split ring 177. The spring 173 is configured to provide a force that induces the threshold friction to retain the control arm 105 in its rotational position relative to the collar 107. As shown, the spring 173 is a coil spring (e.g., helical spring) that is placed into compression upon assembly into a bore of the control arm 105. However, other types of springs may be employed with the tension assembly 163. The control arm 105 includes a first internal stop 155 that retains a first end 173a of the spring 173, and a second internal stop 156 that retains the plug 175, which in turn retains a second end 173b of the spring 173 within the bore of the control arm 105 through the cable 174. As shown, the spring 173 is in compression to provide the force for inducing the friction. However, the spring may be configured to provide the force in tension.

The cable 174 has an elongated portion 174a that extends through the coils of the spring 173, as well as a first end 174b and a second end 174c. The first end 174b of the cable 174 is fixedly coupled to the plug 175. For example, a fitting on the first end 174b may be configured to engage a slot 175a in a body 175b of the plug 175 to retain the cable 174 and fitting to the plug 175. The second end 174c of the cable 174 is coupled to the bushing assembly 161. As shown in FIGS. 26-28, the second end 174c is wound (e.g., wrapped, etc.) around the bushing assembly 161 forming a loop. The second end 174c may be coupled to another portion of the cable 174 to maintain the loop (e.g., size, shape, etc.). The bearing 176 is disposed on the second shoulder 165b of the shaft 165 and, as shown, has an L-shaped cross-sectional

shape. The split ring 177 is disposed on the bearing 176 and, as shown, includes a recess 177a (e.g., a channel, a groove, etc.) in an outer surface for receiving and retaining the second end 174c of the cable 174, which is wound around the split ring 177 within the recess 177a. As shown best in FIG. 28, the split ring 177 is an annular shaped element with a radially extending notch 177b that extends through the thickness of the split ring 177. The notch 177b advantageously allows the cable 174 to compress (e.g., squeeze together) the split ring 177 to create the threshold friction and allow the split ring 177 to rotate with the cable 174 relative to the shaft 165. The bearing 176 may include a similar notch to that of the notch 177b in the split ring 177 (e.g., which may provide the same advantages).

During rotation of the control arm 105 relative to the collar 107, the wound end of the cable 174 is rotated around shaft 165 with the control arm 105. The force from the spring 173 is transferred through the cable 174 to the split ring 177 and/or the bearing 176 to induce the threshold friction between the bushing assembly 161 (e.g., the shaft 165) and the tension assembly 163 (e.g., the split ring 177 and/or bearing 176). This threshold friction maintains the rotational position of the control arm 105 relative to the collar 107, so that the control arm 150 remains in the position without a user having to hold the arm in the selected position.

Other embodiments can be used to retain the position of the control arm 105 relative to the collar 107. For example, one or more spring washers or washers in combination with a spring could be employed to compress together in a direction along the longitudinal axis 165f to generate the threshold friction. It was found that this design had a reduced durability and less control over the friction force compared with the embodiment described above. Also, for example, two gears could be employed to generate the threshold friction. Each gear could include a flat annular element with teeth around a circumference (e.g., a crown gear), such that the teeth of the first gear engage the teeth of the second gear to hold the position until a threshold torque rotates one gear relative to the other gear. It was found that this design produced undesirable noise (e.g., clicking) during rotation and provides limited adjustment set by the number of teeth rather than infinite adjustment according to the above described embodiment.

The control arms disclosed in this application (e.g., control arms 105, 205, 305, 405, 505) or elements of the controls arms may include or be made with a spring biased material, shape memory material, or other suitable material that may provide additional utility (e.g., movement).

As utilized herein, the terms “approximately,” “about,” “substantially,” and similar terms are intended to have a broad meaning in harmony with the common and accepted usage by those of ordinary skill in the art to which the subject matter of this disclosure pertains. It should be understood by those of skill in the art who review this disclosure that these terms are intended to allow a description of certain features described and claimed without restricting the scope of these features to the precise numerical ranges provided. Accordingly, these terms should be interpreted as indicating that insubstantial or inconsequential modifications or alterations of the subject matter described and claimed are considered to be within the scope of the invention as recited in the appended claims.

The terms “coupled,” “connected,” and the like, as used herein, mean the joining of two members directly or indirectly to one another. Such joining may be stationary (e.g., permanent) or moveable (e.g., removable or releasable).

Such joining may be achieved with the two members or the two members and any additional intermediate members being integrally formed as a single unitary body with one another or with the two members or the two members and any additional intermediate members being attached to one another.

References herein to the positions of elements (e.g., “top,” “bottom,” “above,” “below,” etc.) are merely used to describe the orientation of various elements in the FIGURES. It should be noted that the orientation of various elements may differ according to other exemplary embodiments, and that such variations are intended to be encompassed by the present disclosure.

The construction and arrangement of the elements of the faucets as shown in the exemplary embodiments are illustrative only. Although only a few embodiments of the present disclosure have been described in detail, those skilled in the art who review this disclosure will readily appreciate that many modifications are possible (e.g., variations in sizes, dimensions, structures, shapes and proportions of the various elements, values of parameters, mounting arrangements, use of materials, colors, orientations, etc.) without materially departing from the novel teachings and advantages of the subject matter recited. For example, elements shown as integrally formed may be constructed of multiple parts or elements, the position of elements may be reversed or otherwise varied, and the nature or number of discrete elements or positions may be altered or varied.

Additionally, the word “exemplary” is used to mean serving as an example, instance, or illustration. Any embodiment or design described herein as “exemplary” is not necessarily to be construed as preferred or advantageous over other embodiments or designs (and such term is not intended to connote that such embodiments are necessarily extraordinary or superlative examples). Rather, use of the word “exemplary” is intended to present concepts in a concrete manner. Accordingly, all such modifications are intended to be included within the scope of the present disclosure. Other substitutions, modifications, changes, and omissions may be made in the design, operating conditions, and arrangement of the preferred and other exemplary embodiments without departing from the scope of the appended claims.

Other substitutions, modifications, changes and omissions may also be made in the design, operating conditions and arrangement of the various exemplary embodiments without departing from the scope of the present invention. For example, any element (e.g., base, collar, hose, control arm, sprayhead, joint, etc.) disclosed in one embodiment may be incorporated or utilized with any other embodiment disclosed herein. Also, for example, the order or sequence of any process or method steps may be varied or re-sequenced according to alternative embodiments. Any means-plus-function clause is intended to cover the structures described herein as performing the recited function and not only structural equivalents but also equivalent structures. Other substitutions, modifications, changes and omissions may be made in the design, operating configuration, and arrangement of the preferred and other exemplary embodiments without departing from the scope of the appended claims.

What is claimed is:

1. A faucet, comprising:

- a base that is mountable to a mounting surface;
- a sprayhead that is movable relative to the base and is configured to emit water in at least one spray pattern;
- a control arm comprising a first end and a second end, wherein the first end is pivotally connected to the base

15

to allow rotation of the control arm relative to the base, and wherein the second end is detachably coupled to the sprayhead such that in a docked position, movement of the control arm moves the sprayhead relative to the base, and such that in a detached position, the sprayhead is movable relative to the base and the control arm;

a flexible hose separate from and outside of the control arm, wherein the flexible hose connects the sprayhead and the base;

a collar disposed on an end of the base that is opposite a mounting end of the base, wherein the collar is rotatable relative to the base about a longitudinal axis of the base, and wherein the first end of the control arm is pivotally coupled to the base through the collar such that the control arm rotates relative to the collar and the base about a pivot axis that is transverse to the longitudinal axis; and

a retainer that maintains a rotation position of the control arm relative to the base, wherein the retainer comprises:

a bushing assembly rotatably connecting the control arm to the collar, wherein the bushing assembly comprises a shaft having an inner shoulder and an outer shoulder, the inner shoulder coupled to the collar through an aperture thereof, and the outer shoulder coupled to the control arm through an aperture thereof; and

a tension member disposed at least in part within the control arm, wherein the tension member includes a first end and a second end, the first end is coupled to the control arm, and the second end is coupled to the shaft such that the tension member can rotate freely relative to the shaft during rotation of the control arm relative to the collar.

2. The faucet of claim 1, wherein one of the second end of the control arm and the sprayhead includes a magnet that applies a magnetic force to attract the other of the second end and the sprayhead to couple the second end and the sprayhead together in the docked position.

3. The faucet of claim 2, wherein one of the second end of the control arm and the sprayhead includes a ball and the other of the second end and the sprayhead includes a socket, wherein the socket receives the ball in the docked position to detachably couple the sprayhead and the control arm together.

4. The faucet of claim 3, wherein the second end of the control arm includes the socket, wherein the sprayhead includes the ball, and wherein one of the ball and the socket includes the magnet and the other of the ball and the socket comprises a ferromagnetic material.

5. The faucet of claim 3, wherein the second end of the control arm includes the ball, and wherein the sprayhead includes the socket.

6. The faucet of claim 1, wherein the control arm comprises:

a first arm portion having the first end of the control arm; and

a second arm portion having the second end of the control arm;

wherein the first and second arm portions are telescopically adjustable relative to one another.

7. The faucet of claim 6, wherein at least one of the first and second arm portions includes a hollow section such that the other of the first and second arm portions slides within the hollow section during telescopic adjustment.

8. A faucet, comprising:

a base that is mountable to a mounting surface;

16

a sprayhead that is movable relative to the base and is configured to emit water in at least one spray pattern;

a flexible hose connecting the sprayhead and the base;

a collar rotatably disposed on an end of the base, which is opposite a mounting end of the base, so that the collar is rotatable relative to the base about a first axis that extends longitudinally relative to the base;

a control arm comprising:

a first arm having a first end that is pivotally coupled to the base through the collar to allow rotation of the first arm about a second axis relative to the collar and the base, wherein the second axis extends transverse relative to the first axis; and

a second arm having a first end coupled to the sprayhead;

wherein a second end of the first arm and a second end of the second arm are telescopically connected together to adjust a length of the control arm; and

a retainer that maintains a rotation position of the control arm relative to the base, wherein the retainer comprises:

a bushing assembly rotatably connecting the control arm to the collar, wherein the bushing assembly comprises a shaft having an inner shoulder and an outer shoulder, the inner shoulder coupled to the collar through an aperture thereof, and the outer shoulder coupled to the control arm through an aperture thereof; and

a tension member disposed at least in part within the control arm, wherein the tension member includes a first end and a second end, the first end is coupled to the control arm, and the second end is coupled to the shaft such that the tension member can rotate freely relative to the shaft during rotation of the control arm relative to the collar;

wherein the flexible hose is separate from and outside of the control arm.

9. The faucet of claim 8, wherein the first end of the second arm is coupled to the sprayhead through a ball joint comprising a ball and a socket, wherein the second arm includes one of the ball and the socket, and the sprayhead includes the other of the ball and the socket.

10. A faucet, comprising:

a base that is mountable to a mounting surface;

a sprayhead that is movable relative to the base and is configured to emit water in at least one spray pattern;

a flexible hose connecting the sprayhead and the base;

a collar rotatably disposed on the base so that the collar is rotatable relative to the base about a first axis that extends longitudinally relative to the base; and

a control arm comprising:

a first arm having a first end that is pivotally connected to the collar to allow rotation of the first arm about a second axis relative to the collar and the base, wherein the second axis extends transverse relative to the first axis; and

a second arm having a first end coupled to the sprayhead through a ball joint, which comprises a ball and a socket;

wherein the second arm includes one of the ball and the socket, and the sprayhead includes the other of the ball and the socket;

wherein a second end of the first arm and a second end of the second arm are telescopically connected together to adjust a length of the control arm; and

wherein the flexible hose is separate from and outside of the control arm.

17

11. The faucet of claim 10, wherein the collar is disposed on an end of the base that is opposite a mounting end of the base.

12. The faucet of claim 10, wherein the first end of the first arm of the control arm is pivotally coupled to the base through the collar such that the control arm rotates relative to the collar and the base about the second axis.

13. The faucet of claim 10, wherein the sprayhead includes an outer housing and the socket, the socket includes a hollow cylindrical projection extending from a side of the outer housing, and the projection receives the ball of the first end of the second arm.

14. The faucet of claim 10, wherein the collar is disposed on an end of the base that is opposite a mounting end of the base.

15. The faucet of claim 10, wherein the first end of the second arm is detachably coupled to the sprayhead through a magnet and a ferromagnet such that in a docked position, movement of the second arm moves the sprayhead relative to the base, and such that in a detached position, the sprayhead is movable relative to the base and the control arm.

16. A faucet, comprising:

a base that is mountable to a mounting surface;

a collar rotatably coupled to the base such that the collar

is rotatable about a rotational axis relative to the base;

a sprayhead that is movable relative to the base and the

collar, wherein the sprayhead is configured to emit

water in at least one spray pattern;

a control arm coupled to the collar through a first spheroidal joint to allow free rotation of the control arm

relative to the collar, wherein the control arm is coupled

18

to the sprayhead through a second spheroidal joint to allow free rotation of the sprayhead relative to the control arm; and

a flexible hose separate from and outside of the control arm, wherein the flexible hose connects an inlet of the sprayhead and an outlet of the collar.

17. The faucet of claim 16, wherein each of the first and second spheroidal joints comprises a ball and a socket.

18. The faucet of claim 17, wherein the control arm includes the ball of the first spheroidal joint coupled to one end and also includes the ball of the second spheroidal joint coupled to an opposite end.

19. The faucet of claim 18, wherein the collar includes an outer wall and the socket of the first spheroidal joint, which includes a first hollow cylindrical projection extending from the outer wall, and wherein the sprayhead includes an outer housing and the socket of the second spheroidal joint, which includes a second hollow cylindrical projection extending from the outer housing.

20. The faucet of claim 19, wherein the control arm comprises:

a first arm having a first end that is coupled to the first spheroidal joint; and

a second arm having a first end that is coupled to the second spheroidal joint;

wherein a second end of the first arm and a second end of

the second arm are telescopically connected together to

adjust a length of the control arm, such that one of the

first and second arms includes a bore that receives at

least a portion of the other of the first and second arms

in a shortened position.

* * * * *