

(19) World Intellectual Property Organization
International Bureau



(43) International Publication Date
19 December 2002 (19.12.2002)

PCT

(10) International Publication Number
WO 02/102095 A1

- (51) International Patent Classification⁷: **H04Q 7/00**, 7/20, H04B 7/216, 7/208, H04J 3/00
- (21) International Application Number: PCT/US02/18878
- (22) International Filing Date: 13 June 2002 (13.06.2002)
- (25) Filing Language: English
- (26) Publication Language: English
- (30) Priority Data:

60/297,925	13 June 2001 (13.06.2001)	US
09/997,621	29 November 2001 (29.11.2001)	US
60/378,697	7 May 2002 (07.05.2002)	US
10/171,080	12 June 2002 (12.06.2002)	US
- (81) Designated States (*national*): AE, AG, AL, AM, AT, AU, AZ, BA, BB, BG, BR, BY, BZ, CA, CH, CN, CO, CR, CU, CZ, DE, DK, DM, DZ, EC, EE, ES, FI, GB, GD, GE, GH, GM, HR, HU, ID, IL, IN, IS, JP, KE, KG, KP, KR, KZ, LC, LK, LR, LS, LT, LU, LV, MA, MD, MG, MK, MN, MW, MX, MZ, NO, NZ, OM, PH, PL, PT, RO, RU, SD, SE, SG, SI, SK, SL, TJ, TM, TN, TR, TT, TZ, UA, UG, UZ, VN, YU, ZA, ZM, ZW.
- (84) Designated States (*regional*): ARIPO patent (GH, GM, KE, LS, MW, MZ, SD, SL, SZ, TZ, UG, ZM, ZW), Eurasian patent (AM, AZ, BY, KG, KZ, MD, RU, TJ, TM), European patent (AT, BE, CH, CY, DE, DK, ES, FI, FR, GB, GR, IE, IT, LU, MC, NL, PT, SE, TR), OAPI patent (BF, BJ, CF, CG, CI, CM, GA, GN, GQ, GW, ML, MR, NE, SN, TD, TG).

(71) Applicant: **TANTIVY COMMUNICATIONS, INC.**
[US/US]; 1450 South Babcock Street, Melbourne, FL 32901 (US).

Published:
— with international search report

(72) Inventor: **PROCTOR, James, A., Jr.**; 258 Sea View Street, Melbourne Beach, FL 32951 (US).

For two-letter codes and other abbreviations, refer to the "Guidance Notes on Codes and Abbreviations" appearing at the beginning of each regular issue of the PCT Gazette.

(74) Agent: **TAYLOR, Michael, W.**; Allen, Dyer, Dopplet, Milbrath & Gilchrist, P.A., 255 South Orange Avenue, Suite 1401, P.O. Box 3791, Orlando, FL 32802-2000 (US).

(54) Title: TRANSMITTAL OF HEARTBEAT SIGNAL AT A LOWER LEVEL THAN HEARTBEAT REQUEST

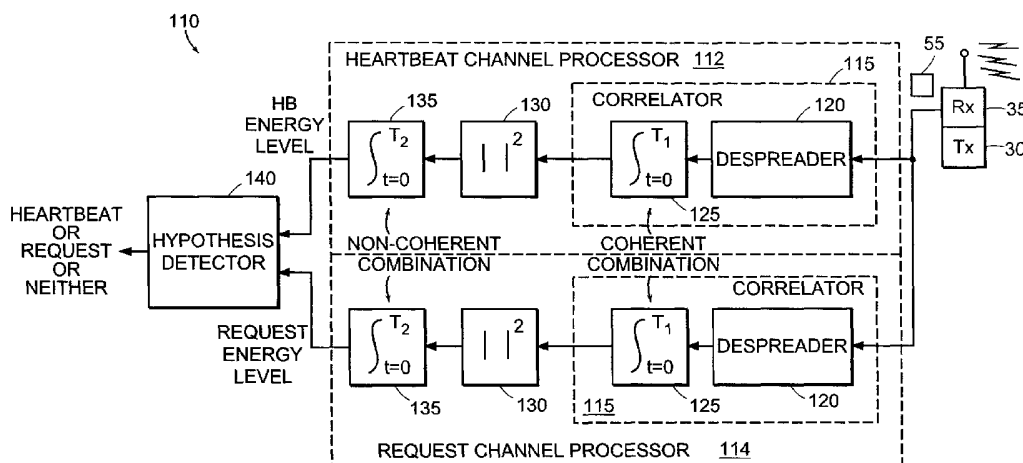

(57) Abstract: A communication system, such as a wireless CDMA system, detects markers with fewer errors by having field units (55) transmit the markers at different power levels (e.g., 9 dB for one marker and 11 dB for another marker). The difference in power levels of the markers allows the base station (110) to identify the request markers using alternative criteria with a low probability of error, where the alternative criteria may include comparing the markers to respective energy level thresholds, monitoring occupancy of time slots, occupancy of mutually exclusive code channels, or combinations thereof. For example, in one particular embodiment, a request marker, which is generally a high priority marker, is transmitted with higher power, which improves the probability of detection and reduces the probability of false detection of the request marker.

WO 02/102095 A1

TRANSMITTAL OF HEARTBEAT SIGNAL AT A LOWER LEVEL THAN
HEARTBEAT REQUEST

BACKGROUND OF THE INVENTION

Increasing use of wireless telephones and personal computers has led to a
5 corresponding increase in demand for advanced telecommunication services that
were once thought practical only for specialized applications. In the 1980s, wireless
voice communications became widely available through cellular telephone
networks. Such services were thought at first to be for the exclusive province of
businessmen because of expected high subscriber costs. The same was also true for
10 access to remotely distributed computer networks, whereby until very recently, only
business people and large institutions could afford the necessary computers and
wireline access equipment.

As a result of the widespread availability of affordable new technologies, the
general population now increasingly desires to have not only wireline access to
15 networks such as the Internet and private intranets, but also wireless access as well.
Wireless technology is particularly useful to users of portable computers, laptop
computers, hand-held personal digital assistants and the like who prefer access to
such networks without being tethered to a telephone line.

There still is no widely available satisfactory solution for providing low cost,
20 high speed access to the Internet, private intranets, and other networks using the
existing wireless infrastructure. This is most likely an artifact of several unfortunate
circumstances. First, the typical manner of providing high speed data service in the
business environment over a wireline network is not readily adaptable to the voice
grade service available in most homes or offices. For example, such standard high
25 speed data services do not necessarily lend themselves to efficient transmission over

-2-

standard cellular wireless handsets because wireless networks were originally designed only to provide voice services. As a result, present day digital wireless communications systems are optimized for voice transmissions, although certain schemes such as CDMA do provide some measure of asymmetrical behavior for the accommodation of data transmissions. For example, the data rate specified by the Telecommunication Industry Association (TIA) for IS-95 on the forward traffic channel is adjustable in increments from 1.2 kbps up to 9.6 kbps for so-called Rate Set 1, and increments from 1.8 kbps up to 14.4 kbps for Rate-Set 2. On the reverse link traffic channel, however, the data rate is fixed at 4.8 kbps.

10 At best, existing wireless systems therefore typically provide a radio channel that can accommodate maximum data rate transfers of 14.4 kilobits per second (kbps) over a forward link direction. Such a low data rate channel does not lend itself directly to transmitting data at rates of 28.8 or even 56.6 kbps that are now commonly available using inexpensive wireline modems, not to mention even higher rates such as the 128 kbps that are available with Integrated Services Digital Network (ISDN) type equipment. Data rates at these levels are rapidly becoming the minimum acceptable rates for activities such as browsing web pages.

15 Although wireline networks were known at the time when cellular systems were initially developed, for the most part, there was no provision made for such wireless systems to provide higher speed ISDN- or ADSL-grade data services over cellular network topologies.

20 In most wireless systems, there are many more potential users than radio channel resources. Some type of demand-based multiple access system is therefore required.

25 Whether the multiple access is provided by the traditional Frequency Division Multiple Access (FDMA) using analog modulation on a group of radio frequency carrier signals, or by schemes that permit sharing of a radio carrier frequency using Time Division Multiple Access (TDMA), or Code Division Multiple Access (CDMA), the nature of the radio spectrum is such that it is expected to be shared. This is quite dissimilar to the traditional environment supporting data

30

transmissions in which the wireline medium is relatively inexpensive and is not typically intended to be shared.

Other factors to consider in the design of a wireless system are the characteristics of the data itself. For example, consider that access to web pages generally is burst-oriented, with asymmetrical data rate transmission requirements in a reverse and forward direction. In a common application, a user of a remote client computer first specifies the address of a web page to a browser program. The browser program then sends the web page address data, which is usually 100 bytes or less in length, over the network to a server computer. The server computer then responds with the content of the requested web page, which may include anywhere from 10 kilobytes to several megabytes of text, image, audio, or even video data. The user thereafter may spend several seconds or even several minutes reading the content of the page before downloading another web page.

In an office environment, the nature of most employees' computer work habits is typically to check a few web pages and then to do something else for an extended period of time, such as accessing locally stored data or even terminating use of the computer altogether. Therefore, even though such users may remain connected to the Internet or private intranet continuously during an entire day, actual use of the high speed data link is usually quite sporadic.

If wireless data transfer services supporting Internet connectivity are to coexist with wireless voice communication, it is becoming increasingly important to optimize the use of available resources in wireless CDMA systems. Frequency reuse and dynamic traffic channel allocation address some aspects of increasing the efficiency of high performance wireless CDMA communication systems, but there is still a need for more efficient utilization of available resources.

SUMMARY OF THE INVENTION

In one application, a transmission of a marker in a time slot over one channel indicates a request by the corresponding field unit to go active. That is, transmission of a marker in an assigned time slot indicates that the field unit is requesting that

reverse link traffic channels be assigned to the user for transmitting a data payload from the field unit to the base station. This presumes that the field unit is presently in the standby mode. Alternatively, a field unit transmits a marker over a second channel of the pair of reverse link channels to indicate that the field unit is not
5 requesting to be placed in the active mode. For example, the field unit does not want to transmit data on a reverse link channel. Rather, the field unit requests to remain inactive but synchronized with the base station so that the field unit can immediately go active again at any moment.

In either case, a wireless communications system employing the principles of
10 the present invention may improve performance of detecting the markers by having the field units transmit the markers at different power levels (e.g., 9 dB for one marker and 11 dB for the other marker), which can improve system performance. The difference in power levels of the markers allows the base station to identify the request markers using alternative criteria with a low probability of error, where the
15 alternative criteria may include comparing the markers to respective energy level thresholds, monitoring occupancy of time slots, occupancy of mutually exclusive code channels, or combinations thereof. For example, in one particular embodiment, a request marker, which is generally a high priority marker, is transmitted with higher power, which improves the probability of detection and reduces the
20 probability of false detection of the request marker.

In one particular CDMA system application, the field unit provides a Heartbeat (HB) channel using a first code in a reverse link to the base station and a heartbeat-with-request (HB/RQST) channel using a second code in the reverse link. In this CDMA application, according to the principles of the present invention, the
25 field unit may transmit the HB and HB/RQST channels with a difference in power levels, preferably giving the HB/RQST the higher power since it is a higher priority signal.

The teachings of the present invention support I-CDMA and 1xEV-DV systems, but are general enough to support systems employing various other
30 communications protocols used in wired or wireless communications systems. Code

Division Multiple Access (CDMA) systems, such as IS-2000, and Orthogonal Frequency Division Multiplexing (OFDM) systems, such as IEEE 802.11a wireless local area network (LAN), may employ an embodiment of the present invention.

BRIEF DESCRIPTION OF THE DRAWINGS

5 The foregoing and other objects, features and advantages of the invention will be apparent from the following more particular description of preferred embodiments of the invention, as illustrated in the accompanying drawings in which like reference characters refer to the same parts throughout the different views. The drawings are not necessarily to scale, emphasis instead being placed upon
10 illustrating the principles of the invention.

Fig. 1 is a schematic diagram of a communications system in which in an embodiment of the present invention may be deployed;

Fig. 2 is a schematic diagram of a subsystem employed by a base station in the communications system of Fig. 1 used to determine whether a reverse link signal
15 includes an indication for a request to change communications states based on an energy level in the signal;

Fig. 3A is a signal diagram of a 1xEV-DV signal with a first marker indicating 'control hold' and a second marker indicating a 'request to go active';

Fig. 3B is a signal diagram of a code division multiple access (CDMA) set of
20 code channels having a marker in an assigned time slot that indicates that the field unit is requesting a change in communications states;

Fig. 3C is a signal diagram of an alternative embodiment of a reverse link signal having the indications; and

Fig. 4 is a plot of signal-to-noise ratio versus probability of detection that
25 may be used in determining energy levels of the indications in the signals of Figs. 3A-3C.

DETAILED DESCRIPTION OF THE INVENTION

A description of preferred embodiments of the invention follows.

In a wireless communications system, an embodiment of the present invention applies to the power that is transmitted from a handset (or the target
5 received power at a base terminal station (BTS)) for a Heartbeat signal (HB) versus a Heartbeat-with-Request signal (HBR, HB/RQST, or just the "request" signal). The HB and HB/RQST signals may be transmitted on a maintenance channel, which, as disclosed in U.S. Serial No. 09/775,305, is a single code channel (out of many) on a reverse link of a CDMA communications system. The maintenance channel is time
10 slotted and different users are assigned different slots.

A field unit in that wireless communications system sends a heartbeat signal to maintain timing and/or power control as well as an indication of presence to the BTS. When a terminal needs an assigned reverse link channel, the terminal then transmits at least one request signal. The signal(s) may be modulated messages or
15 simply coded pilot signals with no "bits".

The requirements for probability of detection and probability of false detection for these channels are quite different. For instance, the detection requirement for HB is relatively low. It may only need to be detected at a rate that is fast enough to track the slew of the timing of the code channel due to physical
20 movement of multi-path structure change resulting from Doppler in the channel. The power control in this case continues to work independent of detection or lack of detection.

For instance, if the signal is not "detected" because the received power is not above a predetermined threshold but the correlation is aligned, the power command
25 indicates that the power was too low and that the terminal should "power up". One requirement, in this particular embodiment, is that the detection occur often enough to allow the detector to be aligned in time to the received signal.

On the other hand, the probability of detection for the request signal is preferably very high as a request signal is considered a high priority signal since a
30 request is an urgent event. Therefore, the request signal may be sent with higher

-7-

power, and the threshold at the BTS may be set differently. This results in a better probability of detection as well as a low probability of false detection.

Thus, according to the principles of the present invention, a different probability of detection and probability of false detection for the heartbeat signal, request signal, or any other signaled message can be employed.

Based on the signal type, an access terminal can transmit the signals with different powers. Various criteria can be used by the BTS for detecting indications of a request sent on the signals. For example, in time slotted channels or mutually exclusive code channels, some slots are occupied when a request is being made versus when a request is not being made. In such a case, either a higher power, presence, or both may be used as detection criteria.

Fig. 1 is a diagram of an example communications system 100, similar to the system described above, employing an embodiment of the present invention. A base station 25 with antenna tower 23 maintains wireless communications links with each of a plurality of field units 42a, 42b, 42c (collectively, field units 42) as shown. Such wireless links are established based upon assignment of resources on a forward link 70 and a reverse link 65 between the base station 25 and field units 42. Each link 65 or 70 is typically made up of several logical reverse link channels 55 and several logical forward link channels 60, respectively.

As shown, the communications system 100 supports wireless communications between an interface 50 and a network 20. Typically, the network 20 is a Public Switched Telephone Network (PSTN) or computer network, such as the Internet, internet, or intranet. The interface 50 is preferably coupled to a digital processing device, such as a portable computer 12, sometimes referred to as an access unit, to provide wireless access to the network 20. Consequently, the portable computer 12 has access to the network 20 based on communications over a combination of both hard-wired and wireless data links.

In a preferred embodiment, the forward link channels 60 and reverse link channels 55 are defined in the communications system 100 as Code Division Multiple Access (CDMA) channels. That is, each CDMA channel is preferably

-8-

defined by encoding and transmitting data over the channel with an augmented pseudo random noise (PN) code sequence. The PN coded data is then modulated onto a radio frequency carrier. This enables a receiver to decipher one CDMA channel from another knowing only the particular augmented PN code assigned for a given channel. In accordance with an embodiment, each channel may occupy a 1.25
5 MHz band consistent with the IS-95 CDMA standard and 1xEV-DV standard and is capable of transmitting at 38.4 kbps.

A forward link 70 includes at least four logical forward link channels 60. As shown, this includes a Pilot Channel 60PL, Link Quality Management (LQM)
10 channel 60L, paging channel 60PG, and multiple traffic channels 60T.

A reverse link 65 includes at least five logical reverse link channels 55. As shown, this includes a heartbeat standby channel 55HS, heartbeat request active channel 55HRA, access channel 55A and multiple traffic channels 55T. Generally, the reverse link channels 55 are similar to the forward link channels 60 except that
15 each reverse link traffic channel 60T can support variable data rates from 2.4 kbps to a maximum of 160 kbps.

Data transmitted between the base station 25 and field unit 42a typically consist of encoded digital information, such as web page data. Based on the allocation of multiple traffic channels in the reverse link 65 or forward link 70,
20 higher data transfer rates can be achieved in a particular link between the base station 25 and field unit 42a. However, since multiple field units 42 compete for bandwidth allocation, a field unit 42a may have to wait until resources are free to be assigned traffic channels to transmit a data payload.

Before discussing an example detector system (Fig. 2) that can be used to distinguish a heartbeat from a heartbeat-with-request signal, a brief discussion of
25 example signals will be discussed in reference to Figs. 3A-3C.

In Fig. 3A, a 1xEV-DV signal 160 that may be transmitted by the field unit is shown having three distinct states: a 'control hold' state 165, a 'request to go active' state 170, and a data traffic state 175. In the 'control hold' state 165, the signal 160
30 does not include a 'request to go active' indication. In other words, the signal 160

remains in an 'idle' or 'control hold' state, which indicates that the field unit 42a is not requesting traffic channels. The 'request to go active' state 170 is an indication that the field unit is requesting to transmit data on a traffic channel over a reverse link to the BTS 25. In the traffic state 175, traffic data is transmitted by the field
5 unit to the BTS. Following transmission of the traffic data over the reverse link, the signal 160 reverts back to the 'control hold' state 165 following a transmission of a 'data transmission complete' state (not shown).

Although shown as a single signal 160, it should be understood that the signal may be multiple signals, optionally coded with orthogonal or non-orthogonal
10 codes into mutually exclusive channels. For example, the 'control hold' state 165 may be transmitted on a different channel from the 'request to go active' state 170. Similarly, the traffic data transmitted in a traffic state 175 may be on a separate channel from the other two states 165, 170. An example of multiple channel is discussed in reference to Figs. 3B and 3C.

15 Fig. 3B is an example of an Internet code division multiple access (I-CDMA) signaling diagram that has assigned time slots for users 1, 2, 3, ... , N repeating in epoch i 177a, epoch $i+1$ 177b, and so forth. The channels are composed of the heartbeat channel 55H, request channel 55R, and traffic channels 55T. Each of these channels has an associated code C1, C2, C3, C4, ..., CN, which allow signals to be
20 transmitted on mutually exclusive code channels. Both the transmitting and receiving systems process the information in the channels by using the codes to separate the information respectively included therein in a typical CDMA manner.

In the example shown, users 1, 2, 4, 5, 6, ..., N are requesting to remain in an idle state, indicated by the presence of a signal 180 in the heartbeat channel 55H.
25 User 3, however, is requesting to transmit data over a reverse link based on a signal 185 in the request channel 55R in the first epoch 177a. In the second epoch 177b, user 3 begins to transmit traffic data 190 in an associated traffic channel using code C5.

Fig. 3C is a more detailed signal diagram of the 1xEV-DV signal of Fig. 3A
30 that is used to indicate a 'request to go active' to the base station 25 from the field

unit 42a. In this embodiment, the 1xEV-DV signal is composed of multiple signals on different logical channels: a heartbeat channel 55H and a request channel 55R. The heartbeat channel 55H provides continuous timing and other information (e.g., power level, synchronization, etc.) from the field unit 42a to the base station 25.

5 The field unit 42a uses the request channel 55R to make a request (e.g., digital “1”) of the base station 25 to request a traffic channel on the reverse link 65 for transmitting data.

Sampling time periods 195a, 195b, ..., 195f (collectively 195) denoted by arrows indicate times or intervals at which the BTS 25 samples the time slots of the request signal 55R and, optionally, the heartbeat channel 55H to determine whether
10 a request for a traffic channel is being made. It should be understood that the sampling may occur over the entire time slot or a subset thereof. Also, the heartbeat channel 55H and request channel 55R use mutually exclusive codes, in this particular embodiment, so the sampling is performed on their mutually exclusive
15 code channels 55H, 55R in all or a subset of time slots. In one particular embodiment, the base station 25 samples mutually exclusive code channels 55H, 55R in time slots designated for request indications, such as in time slots at sampling times 195b, 195d, and 195f. During these time slots, the heartbeat channel 55H is “inactive,” but the request channel 55R is “active”.

20 As discussed above, the signals in the “active” request time slots may be modulated messages or simply coded pilot signals with no “bits”. Thus, detection may be based solely on the respective energy levels of the heartbeat and heartbeat-with-request signals in respective time slots over a given time interval or spanning several time intervals. In one particular embodiment, the ‘control hold’ state 165
25 indication has a first energy level, and the ‘request to go active’ state 170 has a second energy level.

In this particular embodiment, distinguishing the two states may be a matter of measuring energy levels of the signals(s) and (i) comparing the energy levels against at least one threshold or (ii) determining that a request is present, optionally
30 in a mutually exclusive code channel in time slots when the heartbeat signal is at a

logical zero. The different energy levels of the indications may be provided by the duty cycle of the signals, frequency of the signals, power of the signals, signaling structure, and so forth.

To understand how the energy levels of the signals can be used to improve system performance, one can refer to Fig. 4, which provides a chart for selecting signaling requirements based on the following parameters or factors: (i) probability of detection, $P(d)$ (x-axis), (ii) signal-to-noise ratio in decibels (y-axis), and (iii) probability of false detection, $P(fd)$ (curves in the chart). This chart shows a required signal-to-noise ratio at the input terminals of a linear-rectifier detector as a function of probability of detection for a single pulse, with the false-alarm probability $P(fd)$ as a parameter, calculated for a non fluctuating signal. It should be understood that alternative parameters or factors may be used to establish or define the transmitted power levels of the indications.

At the circled point 200, the signal-to-noise ratio is 3 dB, $P(d) = 20\%$, and $P(fd) = 1\%$. To increase the probability of detection for the same probability of false detection, one simply needs to slide the circled point 200 upward along the same probability of false detection curve, which suggests that an increase in the signal-to-noise ratio is used to improve system performance and, thus, improving the likelihood that the request signal will be detected quickly.

Before providing an example model and discussion regarding example Heartbeat standby 55HS and Heartbeat Request Active 55HRA energy levels for the example communications system 100 (Fig. 1), a brief discussion of a processor and detector that may be used in the system is now provided.

Fig. 2 is a schematic diagram of a request detection processor 110 used to determine whether the field unit 42a has requested to send data to the BTS 25. The receiver Rx 35 receives signals 55, which includes the maintenance channel 55N, traffic channels 55T, access channel 55A, heartbeat standby channel 55HS, and heartbeat request active channel 55HRA. The reverse link channels 55 are processed such that a heartbeat channel processor 112 receives the heartbeat standby

-12-

channel 55HS and a request channel processor 114 receives the Heartbeat Request Active channel 55HRA.

The heartbeat channel processor 112 and request channel processor 114 include the same processing elements, in this particular embodiment, so a discussion of just the heartbeat channel processor 112 will be provided for brevity.

The heartbeat channel processor 112 receives the heartbeat standby channel 55HS. A correlator 115 uses a despreader 120 to despread the heartbeat standby channel 55HS. An integrator 125 is used to coherently combine the heartbeat signal. By coherently combining the signal, an integration of I, Q and its phase causes the phase of the signal to be removed and output the power of the signal.

Following the correlator 115, a rectifier 130 (i.e., absolute value of the signal squared) rectifies the power of the signal, which is then integrated by a second integrator 135 to calculate the energy of the received heartbeat signal. The second integrator 135 provides non-coherent combination of the signal, which is calculated over short time intervals. The non-coherent integration provides just magnitudes if the terminal is moving too fast, thus causing a cross-over of the 180-degree phase point, which can cause ambiguities in determining the energy of the signal in the absence of the non-coherent combination.

The output from the heartbeat channel processor 112 is a heartbeat energy level, and the output from the request channel processor 114 is a request energy level. Each of these energy levels, in this particular embodiment, is fed to a hypothesis detector 140, which determines whether a heartbeat signal, request signal, or neither signal is in the reverse link channels 55 received by the base station 25.

To determine which signal(s) is/are present, the hypothesis detector 140 includes logical functions. For example, in this particular embodiment, the hypothesis detector 140 compares a first energy level threshold against the first energy level (i.e., heartbeat energy level) and compares a second energy level threshold against the second energy level (i.e., request energy level).

An example energy level threshold to compare the heartbeat energy level against is 9 dB and the request energy level threshold is 11 dB. The energy level

-13-

thresholds may be dynamically selected, predetermined, or applied in another manner, such as based on a transmitted power level, which may be reported by the field unit to the base station over the heartbeat channel 55H, for instance. In the case of the energy level calculation and comparison, the first and second energy levels
5 may be dependent on occupancy of time slots in the signaling channel(s) used by the signal 55, so the energy level thresholds can be based on an expected or specified number of "1" bits used to indicate a 'request to go active' or to indicate a request to remain in idle mode.

The output of the hypothesis detector 140 may be used to change the state of
10 the communications system. For example, if the hypothesis detector 140 determines that a 'request to go active' (i.e., send a data transmission on the reverse link) is being made by the field unit, then the hypothesis detector outputs a signal to a processor (not shown in the BTS 25) that is responsible for providing the portable computer 12 with a traffic channel 55T. In one embodiment, the BTS 25 allocates
15 the traffic channel 55T if the detected energy level of the signal is determined to be above the second energy level threshold. Alternatively, the BTS allocates the traffic channel 55T if the hypothesis detector 140 determines that the detected energy level is below the second energy level threshold.

As described in reference to Fig. 3C, the heartbeat channel processor 112,
20 request channel processor 114, and hypothesis detector 140 may be configured or designed in a manner that monitors an occupancy of time slots used to indicate the request to change communications states. In one embodiment, the detecting includes monitoring occupancy of mutually exclusive code channels, such as shown in Figs. 3B and 3C.

25 A feedback loop (not shown) may be employed to cause the heartbeat channel processor 112 and request channel processor 114 to be "adaptive". For example, based on the received energy level of the heartbeat channel 55H, the integration time of the integrators 125, 135 may be adjusted, and the energy level thresholds used by the hypothesis detector 140 for comparison of the energy levels
30 of the heartbeat and request signals may also be adjusted by the feedback loop. Such

a feedback loop may use a command or message to transfer information between the BTS and field unit that includes information regarding the power levels of the heartbeat or heartbeat-with-request signals transmitted by the field unit.

As discussed above, the first communications state may be a standby
5 communications state and the second communications state may be a payload
communications state. In other systems or even the same system, the
communications states may refer to other communications states, such as a request
to change base stations, power control signaling, and so forth. The use of different
energy levels in signaling as described herein is applicable to wireless, wired, or
10 optical communications systems. In either case, the communications states may be
used in voice or data communications systems.

As also discussed above, the second energy level may be based on a target
probability of detection, false detection, or combination of both as discussed in
reference to Fig. 4. In other words, the field unit may transmit the request signal at a
15 given power level or a given number of pulses per given time period to achieve a
corresponding signal-to-noise ratio for a given target probability of detection, false
detection, or both as discussed in reference to Fig. 4.

An analysis may be used to set the transmission power or number of
transmitted indications, or a feedback mechanism may be employed in the
20 communications system for causing the field unit to change its behavior so as to
have the received energy levels of the indications achieve a predetermined signal-to-
noise ratio, thus providing the desired probability of detection and false detection
parameters.

SIMULATION:

25 A simulation is now presented that discusses the trades effecting the
probabilities of detection and false detection for the heartbeat (HB) and heartbeat-
with-request (HB/RQST) channels. Recommended SNR targets for HB and
HB/RQST channels are provided. Further, an analytical calculation is made to

-15-

determine a recommended target E/I_o for an acceptable probability of detection and probability of false detection.

- To allow readers to baseline the simulation relative to IS-2000 power control, the reader should be aware that the simulation employs the following
- 5 parameters:
- 800Hz closed loop power control;
 - SNR of the i'th user is calculated as $SNR(i) = P(i) - P_{interference} + \text{processing Gain} + E_r$, where $P_{interference}(i)$ is a total received interference for the i'th user and calculated as $P_{interference}(i) = 20 \cdot \log_{10}(10^{\sum_{j \neq i} (10^{P(j)/20} + 10^{(P_{TH}/20)})})$, where $P(i)$ is the power received from the i'th
 - 10 user and P_{TH} is thermal noise floor and is arbitrarily set to 120 dBm;
 - processing gain is $10 \log 64$;
 - fading model is Jakes;
 - E_r = a Normal distributed random variable with 1 sigma = 0.67 dB
 - 15 error in SNR estimation at the BTS; and
 - power control bit (PCB) errors = 3%.

- In this particular simulation, a choice of a target SNR for the HB channel was chosen first. Based on a 9 dB E/I_o, where E is the entire energy in the heartbeat message and a 95% probability of detection with a 0.1% false detection rate in
- 20 Additive White Gaussian Noise (AWG) is achieved (see Viterbi, A. , CDMA: Principles of Spread Spectrum Communication, Addison Wesley, 1995, p113.)

- Increasing the probability of detection to 99% yields significantly higher false detection rate of 1% in AWGN. This false detection rate is of interest as it should be low enough that non-detection will occur for a relatively long duration
- 25 when the terminal has dropped the communications link with the base station.

Typically, the duration is defined by a timer having a duration of 500ms to 2 sec or 25 to 100 sequential non-detections. For reference, in a single path fading environment with 9 db E/I_o, a 90% detection probability and a 1% false detection

rate is predicted by theory. For this case, the details associated with the detection probability in the fading environment are considered in the following discussion.

Detection of the heartbeat signal with 50 Hz power control versus field unit velocity is now considered. The simulation is based on a full rate model in which
 5 modifications were made such that the power control (PC) rate is 50 Hz and standby terminals are time slotted, non-overlapping.

While the speed of the terminal is irrelevant above about 2 mph, closed-loop power control is seen as useful in allowing the fading to vary around the mean path loss. It is noted that the results are relatively insensitive to a Power Control Bit
 10 (PCB) error rate up to about 40%. Beyond that, the system performed poorly, demonstrating that some form of closed-loop control is needed to maintain the mean path loss. It is therefore useful that some form of closed-loop power control be performed to bring the transmitter (Tx) power of the field unit to the average appropriate for the field unit to achieve the mean path loss to the base station.

15 Simulation using the above parameters shows that if the base station detects the 'request to go active' indication 2 dB below the target SNR (as defined above), then the average time of detection is about 16 ms, with standard deviation at about 14 ms. From the simulation, to achieve a low latency in HB/RQST detection, the following equation has been determined:

$$20 \quad \text{Target_SNR(RQST)} = \text{Target_SNR(HB)} + 2 \text{ dB} \quad (1)$$

Based on the required detecting/false detection rates in AWGN, a Target_SNR of 9 dB for the Heartbeat message and 11 dB for the heartbeat-with-request (HB/RQST) message were chosen. These parameters yield a 15 ms detection latency on average at 20 mph with low probability of false detection.

25 In terms of false assignment probability, while the false detection rate is not explicitly calculated in the simulation, a pessimistic bound is given as follows:

$$\begin{aligned} \text{Pfd(RQST)} &= (1 - \text{Pd(HB)}) * \text{Pfd(HB)} & (2) \\ &= 5\% * 0.1\% = 5E-5, \end{aligned}$$

where Pfd is the probability of false detection and Pd is the probability of detection.

-17-

The above equation and result is a product of two conditions: (i) not detecting the existence of a HB while it is present and (ii) falsely detecting a HB when it is not present. This is a pessimistic bound since the additional 2 dB of transmitted power for HB/RQST versus HB is not included in the analysis.

5 At a HB rate of 50 Hz, this would yield a false assignment for one standby user every 400 seconds on average. For N heartbeat users, the probability is linear since the events are independent. Therefore, for a fully loaded standby user population of 96 for a particular base station, the average false assignment rate is expected to be roughly one every four seconds.

10 A condition of a false assignment can be recovered from relatively quickly as the false assignment can be detected quickly. When a false assignment occurs, three conditions are typically present. First, no traffic shows up on the assigned reverse channel. Second, the heartbeat-with-request signal is not present. If a missed channel assignment has occurred, the HB/RQST continues to be present. Third, the
15 heartbeat message will likely be present. The probability of not detecting this condition in one frame is $P_{fd}(RQST) = 5E-3\%$. This should be detected within one or two frames before the channel can be re-assigned to a legitimate user. If it is assumed that detection takes two frames, the reverse capacity would be reduced by no more than 1% and is likely less as the probability of false detection for the
20 HB/RQST is targeted at 11 dB E/I_o.

 For a signal with no offset between the Target_SNR and the detection threshold, the delay to detection is 35 ms on the average between the simulation with a remote subscriber unit moving at 1 mph and at 20 mph. For the heartbeat-with-request (HB/RQST) signal, the average delay to detection is less than 20ms, with a
25 detection threshold of 2 dB below the target SNR of 11 dB. This is possible since the transmit (Tx) power is increased by 2 dB for the HB/RQST relative to the HB signal.

 The simulation shows that the minimum average, given 96 users in a 20 ms power control (PC) period is close to 10ms. The delay is expected to be better than
30 75ms 99% of the time.

-18-

The simulation also shows that the addition of 2 dB of additional transmit power for the HB/RQST message increases the detection probability and reduces the detection latency to 15ms on average. An estimate of the co-channel total interference of a fully loaded maintenance channel is between 6 dB less than an IS-
5 2000 fundamental channel (9600 bps Reverse Traffic Channel (R-TCH), 9600 bps Reverse Dedicated Control Channel (R-DCCH)).

While this invention has been particularly shown and described with references to preferred embodiments thereof, it will be understood by those skilled in the art that various changes in form and details may be made therein without
10 departing from the scope of the invention encompassed by the appended claims.

CLAIMS

What is claimed is:

1. In a wireless communications system, a method for determining a request to change communications state, the method comprising:
5 receiving at least one signal having a first indication of a first communications state and having a first energy level;
receiving said at least one signal having a second indication for a request to change to a second communications state and having a second energy level; and
10 detecting the indications according to alternative criteria.
2. The method according to Claim 1 wherein the detecting includes comparing a first energy level threshold against the first energy level and comparing a second energy level threshold against the second energy level.
3. The method according to Claim 2 wherein the detecting includes integrating
15 time slots in a signaling channel in which said at least one signal is received, said first and second energy levels being dependent on occupancy of respective time slots.
4. The method according to Claim 2 further including causing the communications system to change to the second communications state if the
20 detected energy level of said at least one signal is determined to be above the second energy level threshold.
5. The method according to Claim 2 further including causing the communications system to change to the second communications state if the

-20-

detected energy level of said at least one signal is determined to be below the second energy level threshold.

6. The method according to Claim 1 wherein the detecting includes monitoring an occupancy of time slots used to indicate the request to change communications states.
7. The method according to Claim 6 wherein the detecting includes applying independent thresholds for detection to the time slots.
8. The method according to Claim 6 wherein the time slots are mutually exclusive.
9. The method according to Claim 8 wherein a request to change communications states is caused by detecting energy levels above respective thresholds in both mutually exclusive time slots, and a request not to change communications states is caused by detecting energy levels above respective energy thresholds on fewer than both mutually exclusive time slots.
10. The method according to Claim 1 wherein the detecting includes monitoring occupancy of mutually exclusive code channels.
11. The mutually exclusive code channels have respective thresholds for detection.
12. The method according to Claim 1 wherein, based on the energy level of the first energy level, the detecting includes setting at least one integration time and an energy level threshold.

-21-

13. The method according to Claim 1 wherein, based on the transmitted power levels of said at least one signal, the detecting includes setting an energy level threshold.
14. The method according to Claim 1 wherein the first communications state is a standby state and the second communications state is a payload communications state.
15. The method according to Claim 1 wherein the wireless communications system is a code division multiple access (CDMA) or orthogonal frequency division multiplexing (OFDM) wireless communications system.
16. The method according to Claim 1 wherein the communications states are data communications states.
17. The method according to Claim 1 further including adjusting the second energy level of the signal based on a target probability of detection.
18. The method according to Claim 1 further including adjusting the second energy level of the signal based on a target probability of false detection.
19. In a wireless communications system, an apparatus for determining a request for changing communications state, the apparatus comprising:
a receiver to receive at least one signal having (i) a first indication of a first communications state at a first energy level and (ii) a second indication for a request to change to a second communications state at a second energy level; and
a detector coupled to the receiver to detect the indications according to alternative criteria.

-22-

20. The apparatus according to Claim 19 wherein the detector includes a comparator to compare a first energy level threshold against the first energy level and to compare a second energy level threshold against the second energy level.
- 5 21. The apparatus according to Claim 20 wherein the detector includes an integrator to integrate over time slots in a signaling channel in which said at least one signal is received, said first and second energy levels being dependent on occupancy of respective time slots
- 10 22. The apparatus according to Claim 20 further including a state selector to cause the communications system to change to the second communications state if the detected energy level of said at least one signal is determined to be above the second energy level threshold.
- 15 23. The apparatus according to Claim 20 further including a state selector to cause the communications system to change to the second communications state if the detected energy level of said at least one signal is determined to be below the second energy level threshold.
24. The apparatus according to Claim 19 wherein the detector includes a time slot monitor to monitor an occupancy of time slots used to indicate the request to change states.
- 20 25. The apparatus according to Claim 24 wherein the detector applies independent thresholds for detection to the time slots.
26. The apparatus according to Claim 24 wherein the time slots are mutually exclusive.

27. The apparatus according to Claim 26 wherein the detector causes a request to change communications states in response to detecting energy levels above respective thresholds in both mutually exclusive time slots, and the detector does not cause a request to change communications states in response to
5 detecting energy levels above respective thresholds in fewer than both mutually exclusive time slots.
28. The apparatus according to Claim 19 wherein the detector includes a code channel monitor to monitor the occupancy of mutually exclusive code channels.
- 10 29. The apparatus according to Claim 19 wherein the detector (i) includes at least one integration unit having respective selectable integration times and (ii) sets an energy level threshold based on the energy level of the first energy level.
- 15 30. The apparatus according to Claim 19 wherein the detector (i) includes an integration unit having a fixed integration time and (ii) sets an energy level threshold based on the transmitted power level of said at least one signal.
31. The apparatus according to Claim 19 wherein the first communications state is a standby state and the second communications state is a payload communications state.
- 20 32. The apparatus according to Claim 19 wherein the wireless communications system is a code division multiple access (CDMA) or orthogonal frequency division multiplexing (OFDM) wireless communications system.
33. The apparatus according to Claim 19 wherein the communications states are data communications states.

-24-

34. The apparatus according to Claim 19 further including adjusting the second energy level of the signal based on a target probability of detection.
35. The apparatus according to Claim 19 further including adjusting the second energy level of the signal based on a target probability of false detection.
- 5 36. In a wireless communications system, an apparatus for determining a request to change communications state, the apparatus comprising:
- means for receiving at least one signal having (i) a first indication of a first communications state at a first energy level and (ii) a second indication for a request to change to a second communications state at a second energy level; and
- 10 means for detecting the indications according to alternative criteria.
37. In a wireless communications system, a method for making a request to change communications state, the method comprising:
- selecting indications to be transmitted in a signal, the indications
- 15 having respective energy levels associated with data communications states and detectable according to alternative criteria; and
- transmitting the signal including at least one indication.
38. The method according to Claim 37 wherein selecting the indications is done according to associated energy levels.
- 20 39. The method according to Claim 37 wherein transmitting the signal includes multiplexing the indications in time slots in a signaling channel.
40. The method according to Claim 39 wherein the energy levels of the indications are selected in a manner considering comparison against independent thresholds by a receiving system.

-25-

41. The method according to Claim 39 wherein the time slots are mutually exclusive.
42. The method according to Claim 41 wherein an indication provided in both mutually exclusive time slots indicates a request to change communications states and an indication provided in fewer than both mutually exclusive time slots indicates a request to remain in the same communications state.
43. The method according to Claim 37 wherein transmitting the signal includes applying the indications in mutually exclusive code channels.
44. The method according to Claim 37 wherein the criteria include at least one of the following: code channel time slot occupancy, associated energy level, indication duration, and indication repetition.
45. The method according to Claim 37 wherein the communications states include a standby state and a payload communications state.
46. The method according to Claim 30 wherein the wireless communications system is a code division multiple access (CDMA) or orthogonal frequency division multiplexing (OFDM) wireless communications system.
47. The method according to Claim 37 wherein the communications states are data communications states.
48. The method according to Claim 37 wherein the respective energy levels of the first and second indications are based on a target probability of detection.

49. The method according to Claim 37 wherein the respective energy levels of the first and second indications are based on a target probability of false detection.
50. In a wireless communications system, an apparatus for making a request to
5 change communications state, the apparatus comprising:
a selector to select indications to be transmitted in a signal, the indications having respective energy levels associated with communications states and detectable according to alternative criteria; and
a transmitter coupled to the selector to transmit the signal including at
10 least one indication.
51. The apparatus according to Claim 50 further including a multiplexer coupled to the selector and transmitter to apply the indications in time slots in a signaling channel.
52. The apparatus according to Claim 51 wherein the energy levels of the
15 indications are selected in a manner considering comparison against independent thresholds by a receiving system.
53. The apparatus according to Claim 51 wherein the time slots are mutually exclusive.
54. The apparatus according to Claim 53 wherein an indication provided in both
20 mutually exclusive time slots indicates a request to change communications states and an indication provided in fewer than both mutually exclusive time slots indicates a request to remain in the same communications state.
55. The apparatus according to Claim 50 wherein the selector applies the indications in mutually exclusive code channels.

-27-

56. The apparatus according to Claim 50 wherein the criteria include at least one of the following: code channel time slot occupancy, associated energy level, indication duration, and indication repetition.
57. The apparatus according to Claim 50 wherein the communications states
5 include a standby state and a payload communications state.
58. The apparatus according to Claim 50 wherein the wireless communications system is a code division multiple access (CDMA) or orthogonal frequency division multiplexing (OFDM) wireless communications system.
59. The apparatus according to Claim 50 wherein the communications states are
10 data communications states.
60. The apparatus according to Claim 50 wherein the selector applies the indications to the signal based on a target probability of detection.
61. The apparatus according to Claim 50 wherein the selector applies the indications to the signal based on a target probability of false detection.
- 15 62. In a wireless communications system, an apparatus for making a request to change communications state, the apparatus comprising:
means for selecting indications to be transmitted in a signal, the indications having respective energy levels associated with communications states and detectable according to alternative criteria; and
20 transmitting means to transmit the signal including at least one indication.

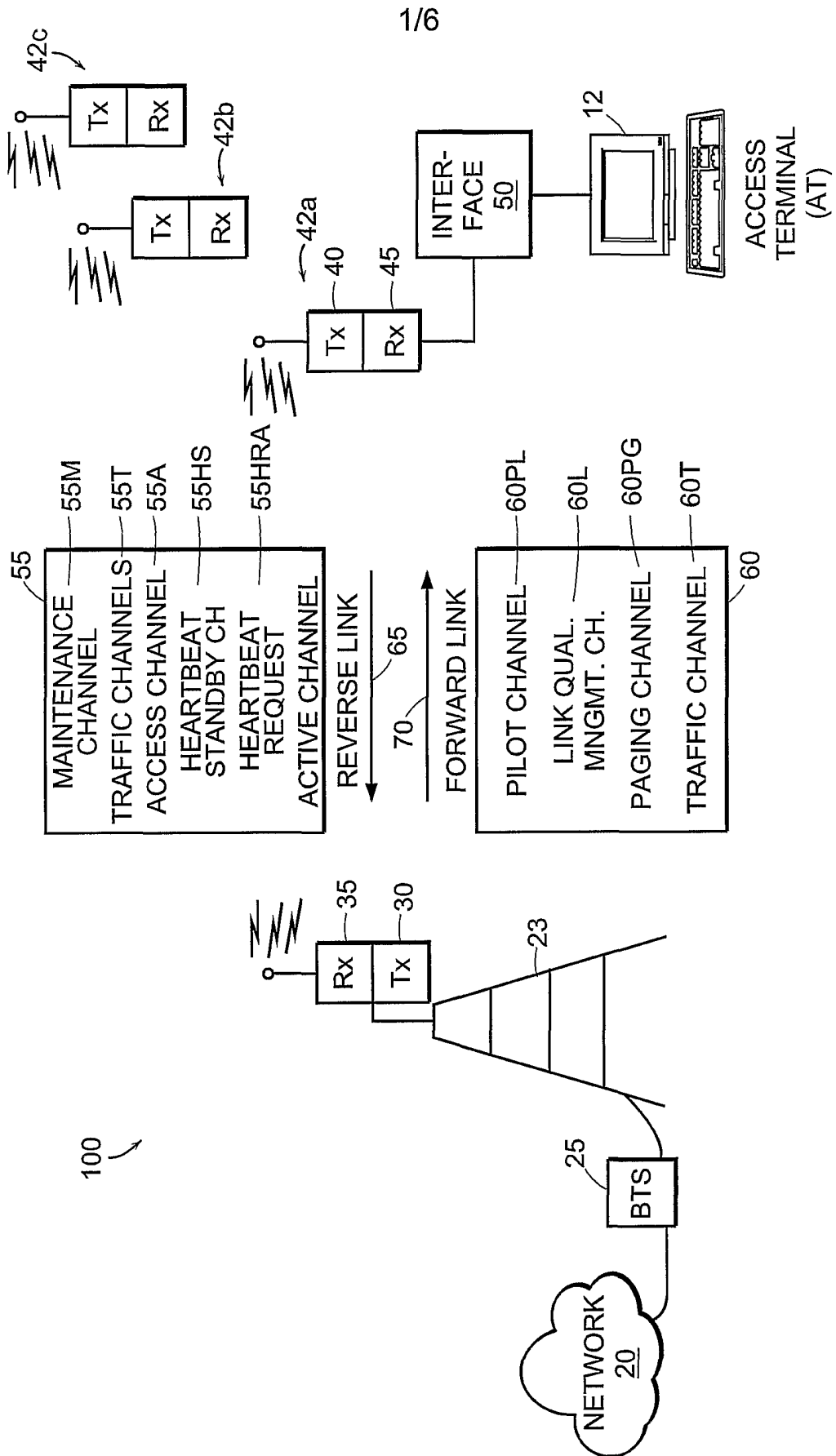

FIG. 1

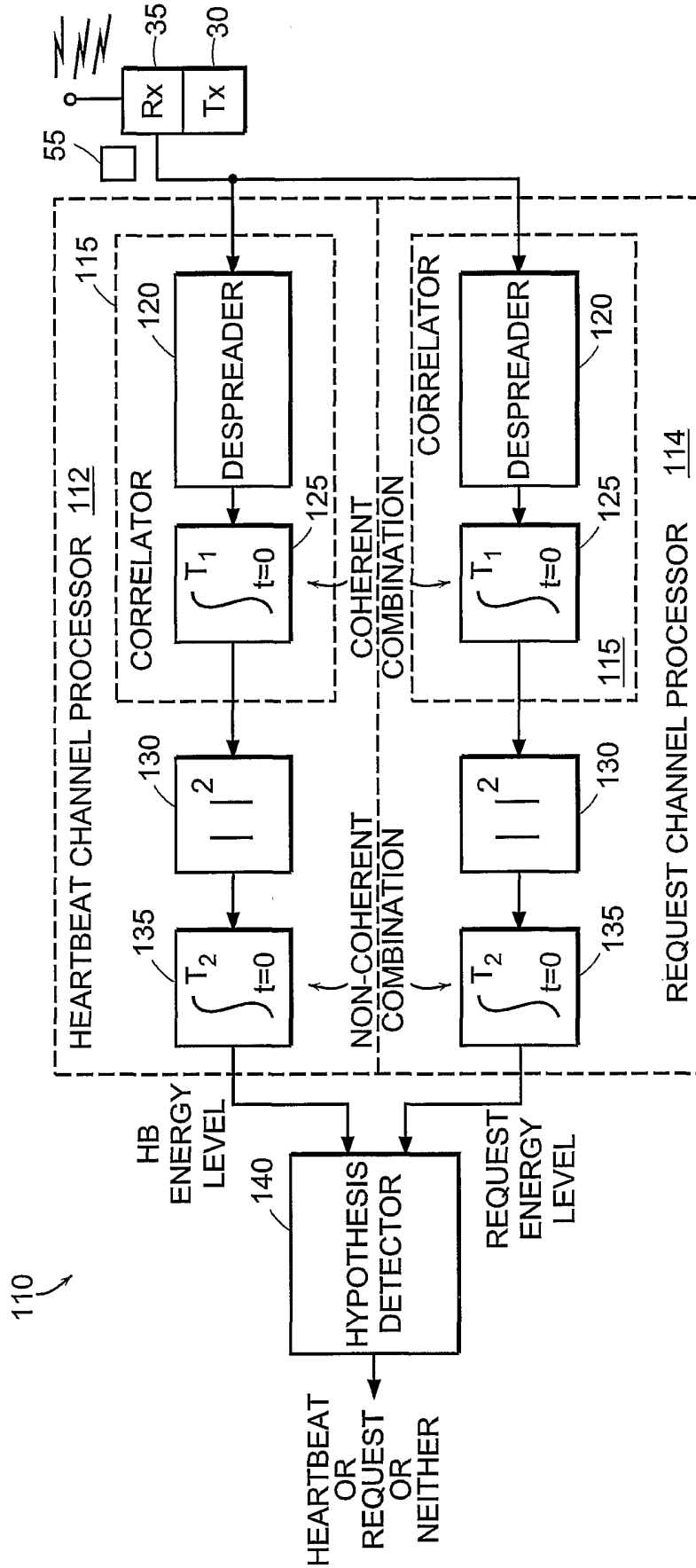

FIG. 2

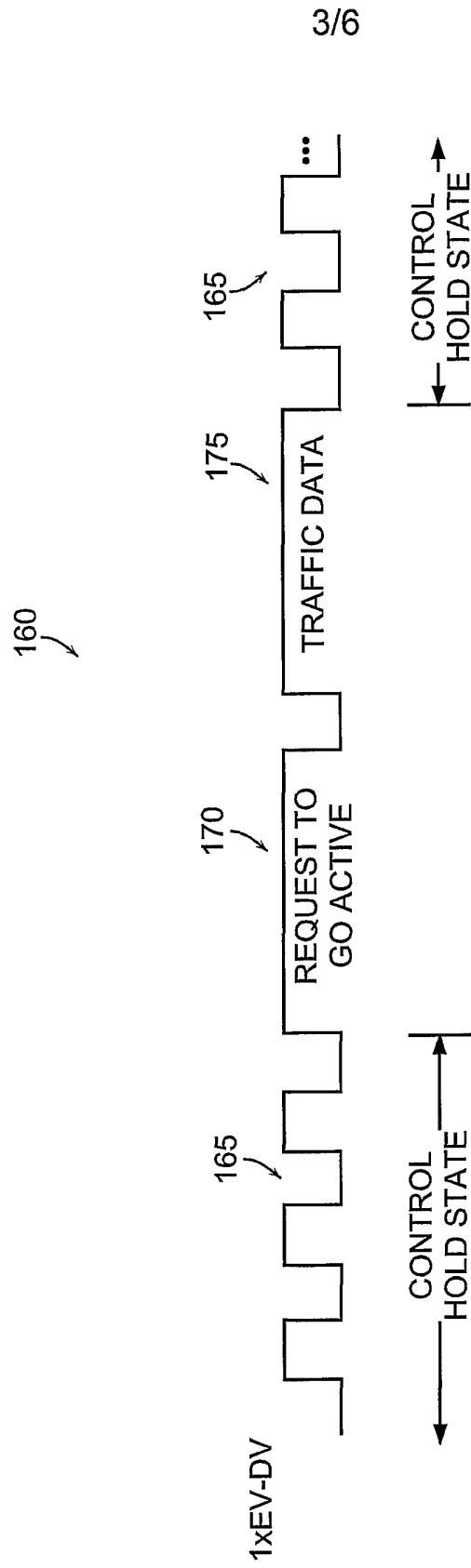

FIG. 3A

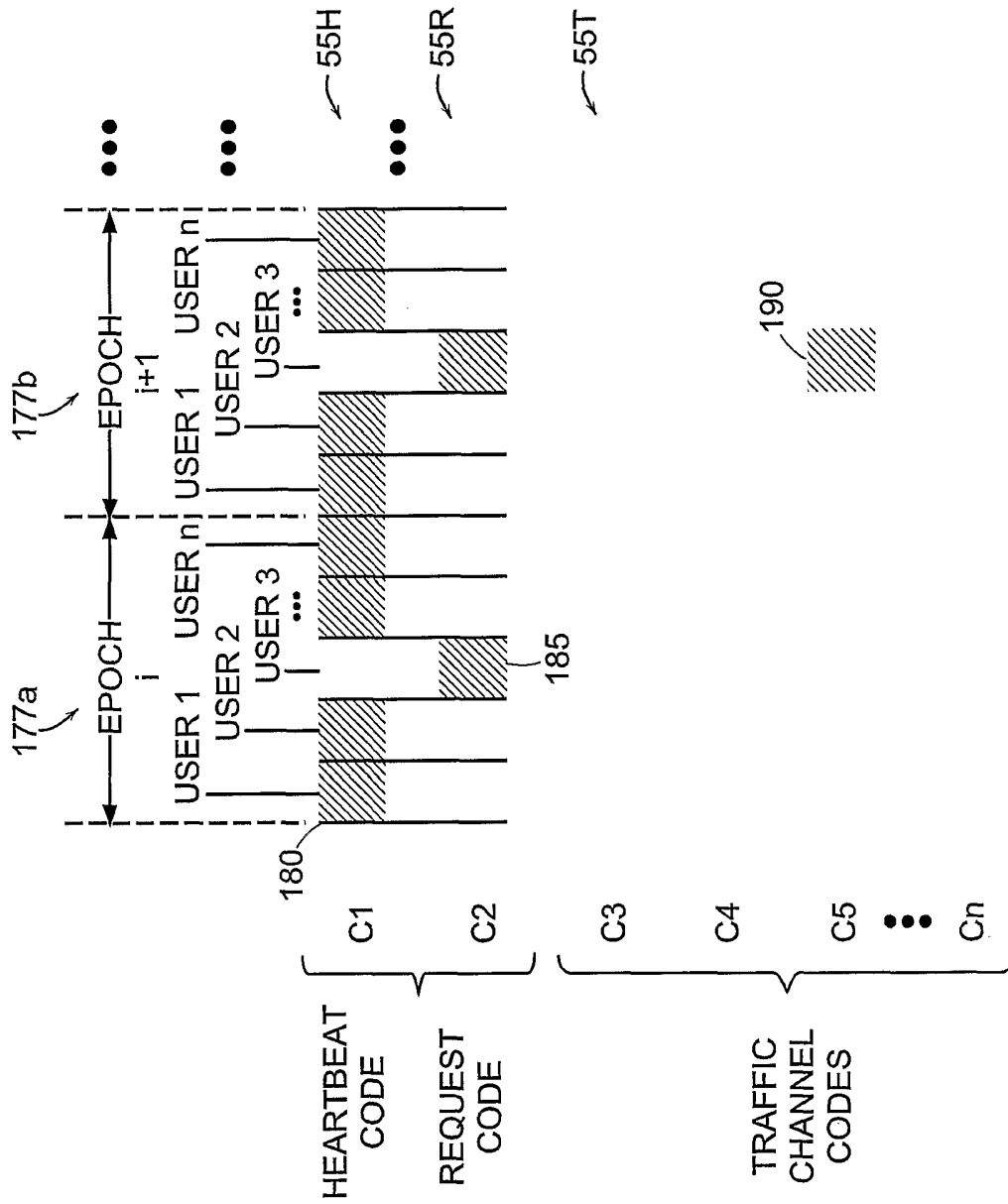

FIG. 3B

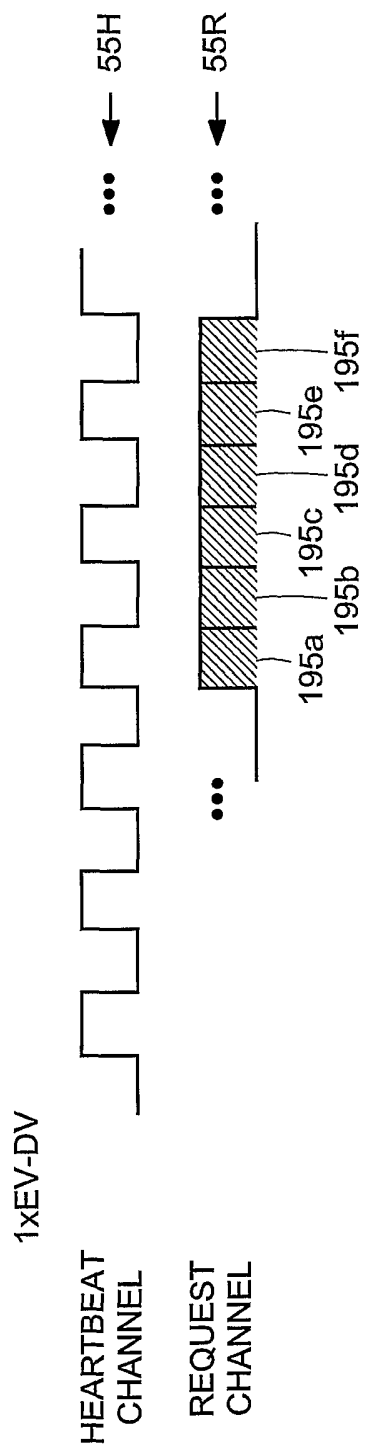

FIG. 3C

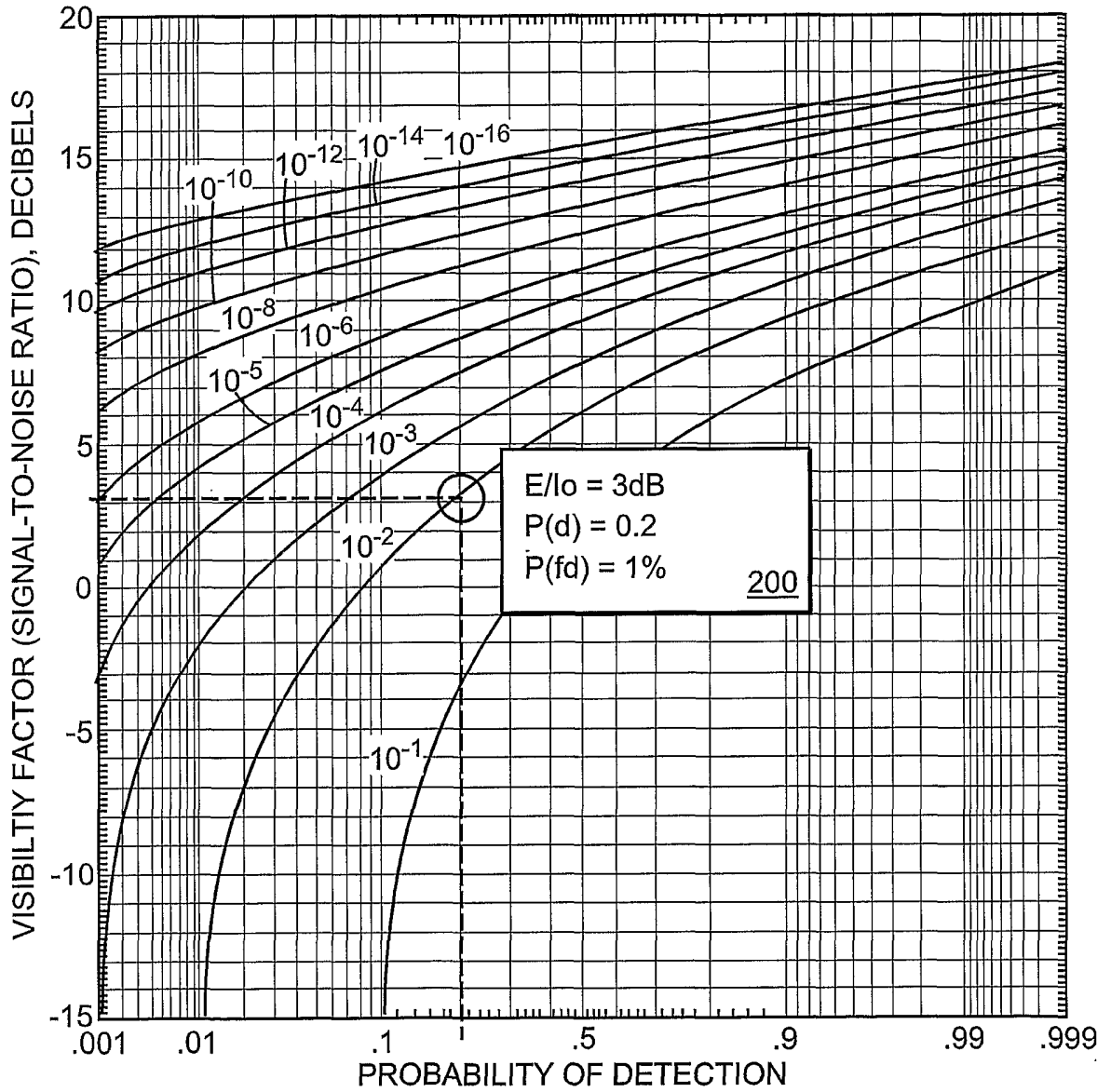

FIG. 4

INTERNATIONAL SEARCH REPORT

International application No.
PCT/US02/18878

A. CLASSIFICATION OF SUBJECT MATTER IPC(7) :H04Q 7/00, 7/20; H04B 7/216, 7/208; H04J 3/00 US CL :370/330, 335, 342, 336, 344, 252; 455/134, 226.2, 502 According to International Patent Classification (IPC) or to both national classification and IPC		
B. FIELDS SEARCHED Minimum documentation searched (classification system followed by classification symbols) U.S. : 370/330, 335, 342, 336, 344, 252; 455/134, 226.2, 502 Documentation searched other than minimum documentation to the extent that such documents are included in the fields searched NONE Electronic data base consulted during the international search (name of data base and, where practicable, search terms used) EAST search terms: CDMA, OFDM, TDMA, heartbeat signal, power, energy level, standby, threshold		
C. DOCUMENTS CONSIDERED TO BE RELEVANT		
Category*	Citation of document, with indication, where appropriate, of the relevant passages	Relevant to claim No.
X	US 5,915,216 A (LYSEJKO) 22 June 1999, col 13, line 65-col 14, line1-38.	1, 2, 4, 5, 12-14, 16, 19,20, 22, 23, 29, 30, 33, 34, 36, 37-39, 45, 47, 50, 57, 59, 62
A	US 6,236,674 B1 (MORELLI et al) 22 May 2001, see abstract	1-62
A	US 6,222,832 B1 (PROCTOR) 24 April 2001, see abstract.	1-62
<input type="checkbox"/> Further documents are listed in the continuation of Box C. <input type="checkbox"/> See patent family annex.		
* Special categories of cited documents:	"T"	later document published after the international filing date or priority date and not in conflict with the application but cited to understand the principle or theory underlying the invention
"A" document defining the general state of the art which is not considered to be of particular relevance	"X"	document of particular relevance; the claimed invention cannot be considered novel or cannot be considered to involve an inventive step when the document is taken alone
"E" earlier document published on or after the international filing date	"Y"	document of particular relevance; the claimed invention cannot be considered to involve an inventive step when the document is combined with one or more other such documents, such combination being obvious to a person skilled in the art
"L" document which may throw doubts on priority claim(s) or which is cited to establish the publication date of another citation or other special reason (as specified)	"G"	document member of the same patent family
"O" document referring to an oral disclosure, use, exhibition or other means		
"P" document published prior to the international filing date but later than the priority date claimed		
Date of the actual completion of the international search 04 SEPTEMBER 2002	Date of mailing of the international search report 03 OCT 2002	
Name and mailing address of the ISA/US Commissioner of Patents and Trademarks Box PCT Washington, D.C. 20231 Facsimile No. (703) 305-5230	Authorized officer ANDREW LEE <i>Rugenia Zogan</i> Telephone No. (703) 305-1600	