



(51) International Patent Classification:

*E21B 4/14* (2006.01)      *E21D 9/10* (2006.01)  
*E21B 4/16* (2006.01)

(21) International Application Number:

PCT/AU2020/051060

(22) International Filing Date:

02 October 2020 (02.10.2020)

(25) Filing Language:

English

(26) Publication Language:

English

(30) Priority Data:

2019903718      03 October 2019 (03.10.2019)      AU

(72) Inventor; and

(71) Applicant: **STRANGE, Warren** [AU/AU]; 8 Nambi Way,  
Kalgoorlie, Western Australia 6433 (AU).

(74) Agent: **VINDURAMPULLE, Christofer** et al.; L25, 525  
Collins Street, Melbourne, Victoria 3000 (AU).

(81) Designated States (*unless otherwise indicated, for every kind of national protection available*): AE, AG, AL, AM, AO, AT, AU, AZ, BA, BB, BG, BH, BN, BR, BW, BY, BZ, CA, CH, CL, CN, CO, CR, CU, CZ, DE, DJ, DK, DM, DO, DZ, EC, EE, EG, ES, FI, GB, GD, GE, GH, GM, GT, HN, HR, HU, ID, IL, IN, IR, IS, IT, JO, JP, KE, KG, KH, KN, KP, KR, KW, KZ, LA, LC, LK, LR, LS, LU, LY, MA, MD, ME, MG, MK, MN, MW, MX, MY, MZ, NA, NG, NI, NO, NZ, OM, PA, PE, PG, PH, PL, PT, QA, RO, RS, RU, RW, SA, SC, SD, SE, SG, SK, SL, ST, SV, SY, TH, TJ, TM, TN, TR, TT, TZ, UA, UG, US, UZ, VC, VN, WS, ZA, ZM, ZW.

(84) Designated States (*unless otherwise indicated, for every kind of regional protection available*): ARIPO (BW, GH, GM, KE, LR, LS, MW, MZ, NA, RW, SD, SL, ST, SZ, TZ, UG, ZM, ZW), Eurasian (AM, AZ, BY, KG, KZ, RU, TJ, TM), European (AL, AT, BE, BG, CH, CY, CZ, DE, DK,

(54) Title: LIQUID HAMMER DRILL

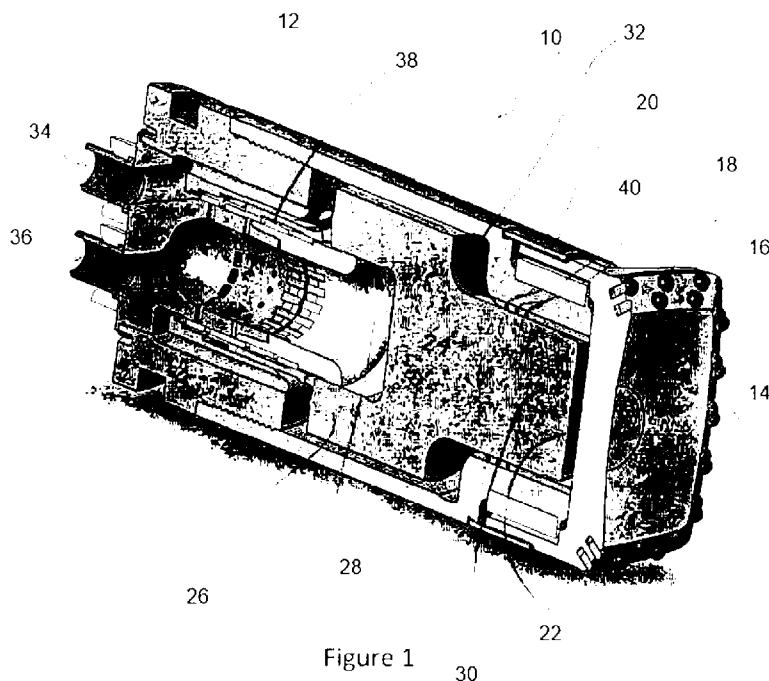

Figure 1

(57) Abstract: A liquid hammer drill comprising: a housing; a drill bit at a leading end of said housing wherein said drill bit includes a trailing end and a leading end that defines a cutting portion; a piston member located inside said housing and having a trailing end, a leading end and an intermediate portion therebetween, said piston member being capable of movement between a first position and a second position at which it impacts the trailing end of the drill bit; a liquid circuit for delivering a liquid to the piston member to cause the piston member to oscillate between its first and second positions and transfer the liquid outside the housing via a liquid outlet; a sealing member for isolating the trailing end of the drill bit from the liquid circuit wherein, in use, the piston member impacts the trailing end of the drill bit in a liquid free environment.



EE, ES, FI, FR, GB, GR, HR, HU, IE, IS, IT, LT, LU, LV,  
MC, MK, MT, NL, NO, PL, PT, RO, RS, SE, SI, SK, SM,  
TR), OAPI (BF, BJ, CF, CG, CI, CM, GA, GN, GQ, GW,  
KM, ML, MR, NE, SN, TD, TG).

**Published:**

— *with international search report (Art. 21(3))*

## LIQUID HAMMER DRILL

### FIELD OF THE INVENTION

The present invention relates to an improved liquid hammer drill. More particularly the present invention relates to a relatively short liquid hammer drill with a number  
5 of performance advantages. The present invention also relates to a cutter head assembly and to a tunnel boring machine.

### BACKGROUND TO THE INVENTION

In the mining industry, large bore shafts, either vertical, angle or horizontal, have been created with the use of percussion tools for many years.

10 Cluster drills traditionally use air percussion hammers and all of the drill cuttings are blown with air pressure and air volume (CFM) out of the shaft. However, cluster drills with air hammers are very long and require very large air volumes which makes them unsuitable for use in tunnel boring machines (TBM). In this regard,  
15 the air exhausted from such TBMs would mean that the tunnel behind the TBM while operating would not be accessible.

Water hammer drills have also been in use for many years. However, the requirement for high volumes of water to operate these drills and the difficulties created by the exhausted water makes them unsuitable for use as part of a TBM.

The present invention seeks to provide a liquid hammer drill that addresses the  
20 problems discussed above. At the very least the present invention seeks to provide an alternative to current solutions for drills suitable for use in TBMs.

### SUMMARY OF THE INVENTION

According to a first aspect, the present invention provides a liquid hammer drill comprising:

25 (a) a housing;

- (b) a drill bit at a leading end of said housing wherein said drill bit includes a trailing end and a leading end that defines a cutting portion;
- (c) a piston member located inside said housing and having a trailing end, a leading end and an intermediate portion therebetween, said piston member being  
5 capable of movement between a first position and a second position at which it impacts the trailing end of the drill bit;
- (d) a liquid circuit for delivering a liquid to the piston member to cause the piston member to oscillate between its first and second positions and transfer the liquid outside the housing via a liquid outlet;
- 10 (e) a sealing member for isolating the trailing end of the drill bit from the liquid circuit wherein, in use, the piston member impacts the trailing end of the drill bit in a liquid free environment.

According to a second aspect the present invention provides a cutter head assembly for a tunnel boring machine, the cutter head assembly comprising:

- 15 (a) a cutter head including a cutting face;
- (b) an array of liquid hammer drills according to a first aspect of the present invention.

According to a third aspect, the present invention provides a tunnel boring machine comprising an array of liquid hammer drills according to a first aspect of the present  
20 invention.

#### **BRIEF DESCRIPTION OF DRAWINGS**

In order to facilitate a better understanding of the present invention, preferred embodiments are described herein with reference to the accompanying drawings, in which:

- 25 Figure 1 is perspective view of a liquid hammer drill according to one embodiment of the first aspect of the present invention including a cut away to show the internal components of the drill;

Figure 2A is a perspective view of a drill bit that can form part of the liquid hammer drill of the present invention; and

Figure 2B is an end view of the trailing end of the drill in Figure 2A.

#### DETAILED DESCRIPTION OF THE INVENTION

- 5 According to a first aspect of the invention, there is provided a liquid hammer drill comprising:
- (a) a housing;
  - (b) a drill bit at a leading end of said housing wherein said drill bit includes a trailing end and a leading end that defines a cutting portion;
  - 10 (c) a piston member located inside said housing and having a trailing end, a leading end and an intermediate portion therebetween, said piston member being capable of movement between a first position and a second position at which it impacts the trailing end of the drill bit;
  - (d) a liquid circuit for delivering a liquid to the piston member to cause the  
15 piston member to oscillate between its first and second positions and transfer the liquid outside the housing via a liquid outlet;
  - (e) a sealing member for isolating the trailing end of the drill bit from the liquid circuit wherein, in use, the piston member impacts the trailing end of the drill bit in a liquid free environment.
- 20 Preferably, the liquid hammer drill is relatively short in terms of length. For the purposes of the present invention, the term "relatively short" is intended to differentiate the liquid hammer drill from existing hammer drills that tend to be longer. Preferably, the liquid hammer drill has a length of or about 0.8, 0.9, 1, 1.1 or 1.2m. Even more preferably, the liquid hammer drill has a length of equal to or  
25 less than 0.7, 0.8, 0.9 or 1m.
- Preferably, the liquid hammer drill has a width or diameter of about 7 to 75, 10 to 65, 15-50 or 25-40cm.

Preferably, the ratio of the length of the liquid hammer drill to its width is less than 6, 5.5, 5, 4.5, 4, 3.5, 3, 2.5 or 2. Preferably, the width referred to in the ratio is the largest width of the liquid hammer drill. For example, if the liquid hammer drill has a non uniform width, the ration is based on the largest width thereof.

- 5 Preferably, the liquid is water, salt water, petroleum or liquified gas.

Preferably, the housing is generally cylindrical.

Preferably, the housing has a circular cross section.

Preferably, the housing defines a tapered leading end.

Preferably, the housing comprises a leading end adapted to receive the drill bit.

- 10 Preferably, the housing is adapted to removably receive the drill bit.

Preferably, the housing defines a retention member for the drill bit. Even more preferably, the retention member is a collar member or chuck supported on the housing. Preferably, the retention member includes a first threaded portion adapted to engage with a second threaded portion of the drill bit. Preferably, the

- 15 collar member is generally ring shaped.

Preferably, the housing defines a port for the liquid inlet circuit and/or the liquid outlet circuit. Even more preferably said port is located at the trailing end of the housing.

Preferably, the drill bit has a relatively low profile.

- 20 Preferably, the drill bit is mounted to the outside of the housing. Even more preferably, the drill bit comprises a collar member or shank that extends over an outside portion of the housing when the drill bit is fitted. Preferably, the collar member comprises a threaded portion. It will be understood that by mounting the drill bit on the outside of the housing, the piston member can, relative to prior art
- 25 hammer drills, be located closer to the trailing end of the drill bit. This, in turn, allows the leading end of the piston member or strike face to be close to the drill face e.g. abut 50 to 100mm from the drill face.

Preferably, the drill bit has a relatively short bit reach. Even more preferably the drill bit has a reach of about 50, 60, 70, 80 or 90mm.

Preferably, the drill bit comprises a threaded portion for removably attaching the drill bit to the drill.

Preferably, the drill bit defines a strike face for the piston member at its trailing end.

Preferably, the strike face comprises at least one water relief groove. In this regard,  
5 if any liquid does ingress to the trailing end of the drill bit then said water relief grooves ensure the piston member still strikes the drill bit in a substantially liquid free environment.

Preferably, the drill bit defines at least one locating member that co-operates with a compatible member to positively locate the drill bit and control its movement when  
10 in use. Preferably the locating member and the compatible member are a spline or groove.

Preferably, the cutting face has a substantially circular cross section. Alternatively, the cutting face may have a substantially polygonal cross section such as a square shaped cross section.

15 Preferably, the cutting face has a relatively low profile or thickness.

Preferably, the cutting face comprises a plurality of buttons. Preferably, the buttons are ovoid shaped.

Preferably, the cutting face defines at least one groove to assist with clearing chips away from the cutting face during use.

20 Preferably, the drill bit comprises at least one aperture therethrough to allow for the passage of fluid. Preferably, said aperture comprises a vent for air and or liquid that enters the area immediately adjacent to the strike face or trailing end of the drill bit.

Preferably, the piston member comprises a main body portion at its trailing end and  
25 its leading end tapers in relative to the main body portion.

Preferably, the intermediate portion defines a shoulder.

Preferably, the main body portion defines a cavity therein for receiving the liquid, during use to move the piston member to its second position.

Preferably, the piston member has a generally circular cross section.

Preferably the piston member, in use, has a travel distance or stroke of about 20, 25, 30 or 35mm.

Preferably, the liquid circuit is closed.

- 5 Preferably, the liquid circuit does not exhaust liquid via the drill bit.

Preferably, the liquid circuit comprises a return portion that delivers the liquid transferred outside the housing via the liquid outlet back into the liquid circuit. In this regard, liquid used in the liquid hammer drill can be circulated and reused.

- 10 Preferably, the liquid circuit further comprises a flow controller operable to move between a first and a second position to create pressure differentials that move the piston between its first and second positions. In this regard, the flow controller works in the usual fashion of a conventional water powered down the hole (DTH) hammer. Preferably, the pressure differentials are between the trailing end of the piston member and the liquid outlet.

- 15 Preferably, the sealing member is located towards the leading end of the piston member.

Preferably, the sealing member is located between the leading end of the piston member and an adjacent section of the housing.

- 20 Preferably, the sealing member is adapted to prevent any liquid from contacting the trailing end of the drill bit such that when the piston member strikes the trailing end of the drill bit it does so in a liquid free environment. However, it will be appreciated that if a small amount of liquid passes the sealing member the liquid hammer drill will still operate as intended. In this regard, for the purposes of the present invention the term "liquid free environment" means an environment that is  
25 free or substantially free of liquid.

Preferably, the sealing member comprises an O-ring or similar device.

Preferably, the sealing member comprises a plurality of O-rings or similar devices.

According to a second aspect of the invention, there is provided a cutter head assembly for a tunnel boring machine, the cutter head assembly comprising:

(a) a cutter head including a cutting face;

(b) an array of liquid hammer drills according to a first aspect of the present invention.

According to a third aspect of the invention, there is provided a tunnel boring  
5 machine comprising an array of liquid hammer drills according to a first aspect of  
the present invention.

Preferably, the tunnel boring machine comprises a cutter head assembly according  
to a second aspect of the present invention.

#### General

10 Those skilled in the art will appreciate that the invention described herein is  
susceptible to variations and modifications other than those specifically described.  
The invention includes all such variation and modifications. The invention also  
includes all of the steps and features referred to or indicated in the specification,  
individually or collectively and any and all combinations or any two or more of the  
15 steps or features.

Each document, reference, patent application or patent cited in this text is  
expressly incorporated herein in their entirety by reference, which means that it  
should be read and considered by the reader as part of this text. That the  
document, reference, patent application or patent cited in this text is not repeated  
20 in this text is merely for reasons of conciseness. None of the cited material or the  
information contained in that material should, however be understood to be  
common general knowledge.

The present invention is not to be limited in scope by any of the specific  
embodiments described herein. These embodiments are intended for the purpose  
25 of exemplification only. Functionally equivalent products and methods are clearly  
within the scope of the invention as described herein.

The invention described herein may include one or more range of values (e.g. size  
etc). A range of values will be understood to include all values within the range,  
including the values defining the range, and values adjacent to the range which

lead to the same or substantially the same outcome as the values immediately adjacent to that value which defines the boundary to the range.

Throughout this specification, unless the context requires otherwise, the word "comprise" or variations such as "comprises" or "comprising", will be understood to  
5 imply the inclusion of a stated integer or group of integers but not the exclusion of any other integer or group of integers.

Other definitions for selected terms used herein may be found within the detailed description of the invention and apply throughout. Unless otherwise defined, all technical terms used herein have the same meaning as commonly understood to  
10 one of ordinary skill in the art to which the invention belongs.

The present invention now will be described more fully hereinafter with reference to the accompanying drawings, in which preferred embodiments of the invention are shown. This invention may, however, be embodied in many different forms and should not be construed as limited to the embodiments set forth herein; rather,  
15 these embodiments are provided so that this disclosure will be thorough and complete, and will fully convey the scope of the invention to those skilled in the art. Like numbers refer to like elements throughout.

## **DESCRIPTION OF THE PREFERRED EMBODIMENTS**

A liquid hammer drill according to one embodiment of the first aspect of the present  
20 invention is depicted in Figure 1 and generally indicated by the numeral 10.

The drill 10 includes a housing 12 and a drill bit 14 at the leading end of the housing 12. The drill bit 14 includes a leading end defining a cutting portion 16 that includes a plurality of ovoid shaped toughened buttons 18. Whilst not shown in Figure 1, the cutting portion 16 includes an aperture that allows for any ingress fluid (air or  
25 liquid) to be expelled.

The drill bit 14 has a relatively low profile and is removably attached to the housing 12 with a bit retention means in the form of collar 20 that allows for the drill bit 14 to be threaded on to the housing 12. The trailing end 22 of the drill bit 14 defines a strike face that is described further hereunder.

The drill 10 further comprises a piston member in the form of piston 24, located inside the housing 12. The piston 24 has a generally circular cross-sectional shape and has a trailing end 26 that defines a cavity 28, a leading end 30 and an intermediate portion therebetween that defines a shoulder 32. The leading end 30 is tapered or narrower relative to the trailing end 26. The piston 24 is capable of movement between a first position and a second position at which its leading end 30 impacts the trailing end 22 of the drill bit 14 and is operable by a liquid circuit that delivers liquid to the piston member via inlet 34 and transfers the liquid outside the housing via outlet 36. Conventionally, liquid is exhausted to the cutting face of the drill bit 14 but the present invention allows for the exhaust of the liquid to be captured via the outlet 36. Thus, the liquid is contained and exits the housing via outlet 36 so it can be delivered back to the drill via inlet 34. This represents an essentially closed liquid circuit.

Between the inlet 34 and outlet 36 is a flow controller in the form of a valve 38. Liquid, such as water, is delivered to the drill via inlet 34 and differential pressure between the inlet 34 and outlet 36 causes the valve 38 to move between first and second positions that in turn creates a pressure differential that causes the piston 24 to oscillate between its first and second positions and repeatedly strike the trailing end 22 of the drill bit 12. The frequency of the oscillation being a product of the differential pressure. This oscillating movement corresponds to that widely used in water hammer drills and is familiar to those skilled in the art.

When the piston 24 strikes the trailing end 22 of the drill bit 14, it does so in a substantial liquid free environment. The substantial liquid free environment is a result of the action of the sealing member in the form of the O-ring seals 40 that isolate the trailing end 22 of the drill bit 14 from the water. Although some water may pass the O-ring seals 40 any such ingress does not overly compromise the operation of the drill 10.

An alternate embodiment of the drill bit that forms part of the drill according to the first aspect of the present invention is depicted in Figures 2A and 2B and generally indicated by the numeral 114.

The drill bit 114 also has a relatively low profile and a relatively short bit reach of

about 70mm and is adapted to be threaded onto the housing via a threaded engagement on collar 180. The drill bit 114 has a generally square shaped cross section but incorporates an irregular shaped outside edge created by a plurality of cut-outs 162 that form a scalloped edge. The cutting face of the drill bit 114 includes a plurality of buttons 118 of toughened material and a pair of grooves 160a, 160b that run diagonally across the cutting face and assist with the removal of material away from the cutting face during use. At the centre of the cutting face is an aperture 170 that allows for any fluid (air or liquid) to be expelled from inside the housing of the drill.

The trailing end of the drill bit 114, best shown in Figure 2B, includes a pair of water relief grooves 172a, 172b to manage any liquid ingress to the trailing end of the drill bit 114. A locating member in the form of a series of splines 174 located around the periphery of the inside of the collar 180 assist with the location and engagement of the drill bit 114.

Advantages, in use, of the present invention including one or more of the performance features in the table below where #1, #2 and #3 represent 3 different embodiments of a drill according to a first aspect of the present invention:

	#1	#2	#3	Units
Pressure Differential	1500	2000	2500	Psi
Piston Stroke	30.0	30.0	30.0	Mm
Piston Mass	255.0	255.0	255.0	Kg
Bit Mass	135.0	135.0	135.0	Kg
Piston/Bit Wt Ratio	1.89	1.89	1.89	
Piston Velocity at Impact	4.20	4.83	5.39	m/s
Impact Energy	2251	2976	3701	J
Bit Velocity after Impact	7.94	9.13	10.18	m/s
Impact Energy	4252	5622	6991	J
Number Of Strokes/Second	7.35	14.28	18.37	Hz
Valve Velocity - Up	6.17	7.13	7.98	m/s
Down	6.28	7.24	8.09	m/s
Flow rate	25.4	49.4	63.6	(US) GPM
	96.3	187.1	240.7	L/min
No of buttons in bit	40.0	40.0	40.0	
Impact Energy per button	106	141	175	J

**THE CLAIMS DEFINING THE INVENTION ARE AS FOLLOWS:**

1. A liquid hammer drill comprising:
  - (a) a housing;
  - (b) a drill bit at a leading end of said housing wherein said drill bit includes a trailing end and a leading end that defines a cutting portion;
  - (c) a piston member located inside said housing and having a trailing end, a leading end and an intermediate portion therebetween, said piston member being capable of movement between a first position and a second position at which it impacts the trailing end of the drill bit;
  - (d) a liquid circuit for delivering a liquid to the piston member to cause the piston member to oscillate between its first and second positions and transfer the liquid outside the housing via a liquid outlet;
  - (e) a sealing member for isolating the trailing end of the drill bit from the liquid circuit wherein, in use, the piston member impacts the trailing end of the drill bit in a liquid free environment.
2. A liquid hammer drill according to claim 1 wherein the ratio of the length of the liquid hammer drill to its width is less than 6, 5.5, 5, 4.5, 4, 3.5, 3, 2.5 or 2.
3. A liquid hammer drill according to claim 1 or 2 wherein the liquid is water, salt water, petroleum or liquified gas.
4. A liquid hammer drill according to any one of the preceding claims wherein the drill bit has a reach of about 50, 60, 70, 80 or 90mm.
5. A liquid hammer drill according to any one the preceding claims wherein the drill bit defines a strike face for the piston member at its trailing end and said strike face comprises at least one water relief groove.
6. A liquid hammer drill according to any one of the preceding claims wherein the drill bit comprises at least one aperture therethrough to allow for the passage of fluid.
7. A liquid hammer drill according to any one of the preceding claims wherein the

piston member comprises a main body portion at its trailing end and its leading end is narrower than the main body portion.

8. A liquid hammer drill according to any one of the preceding claims wherein the intermediate portion of the piston member defines a shoulder.
9. A liquid hammer drill according to any one of the preceding claims wherein the main body portion of the piston member defines a cavity therein for receiving the liquid, during use, to move the piston member to its second position.
10. A liquid hammer drill according to any one of the preceding claims wherein the piston member, in use, has a travel distance or stroke of about 20, 25, 30 or 35mm.
11. A liquid hammer drill according to any one of the preceding claims wherein the liquid circuit is closed.
12. A liquid hammer drill according to any one of the preceding claims wherein the liquid circuit does not exhaust liquid via the drill bit.
13. A liquid hammer drill according to any one of the preceding claims wherein the liquid circuit comprises a return portion that delivers the liquid transferred outside the housing via the liquid outlet back into the liquid circuit.
14. A liquid hammer drill according to any one of the preceding claims wherein the sealing member is located towards the leading end of the piston member.
15. A liquid hammer drill according to any one of the preceding claims wherein the sealing member is located between the leading end of the piston member and an adjacent section of the housing.
16. A liquid hammer drill according to any one of the preceding claims wherein the sealing member is adapted to prevent any liquid from contacting the trailing end of the drill bit such that when the piston member strikes the trailing end of the drill bit it does so in a liquid free environment.
17. A cutter head assembly for a tunnel boring machine, the cutter head assembly comprising:
  - (a) a cutter head including a cutting face;

(b) an array of liquid hammer drills according to any one of the preceding claims.

18. A tunnel boring machine comprising an array of liquid hammer drills according to any one of claims 1 to 16 or a cutter head assembly according to claim 17.

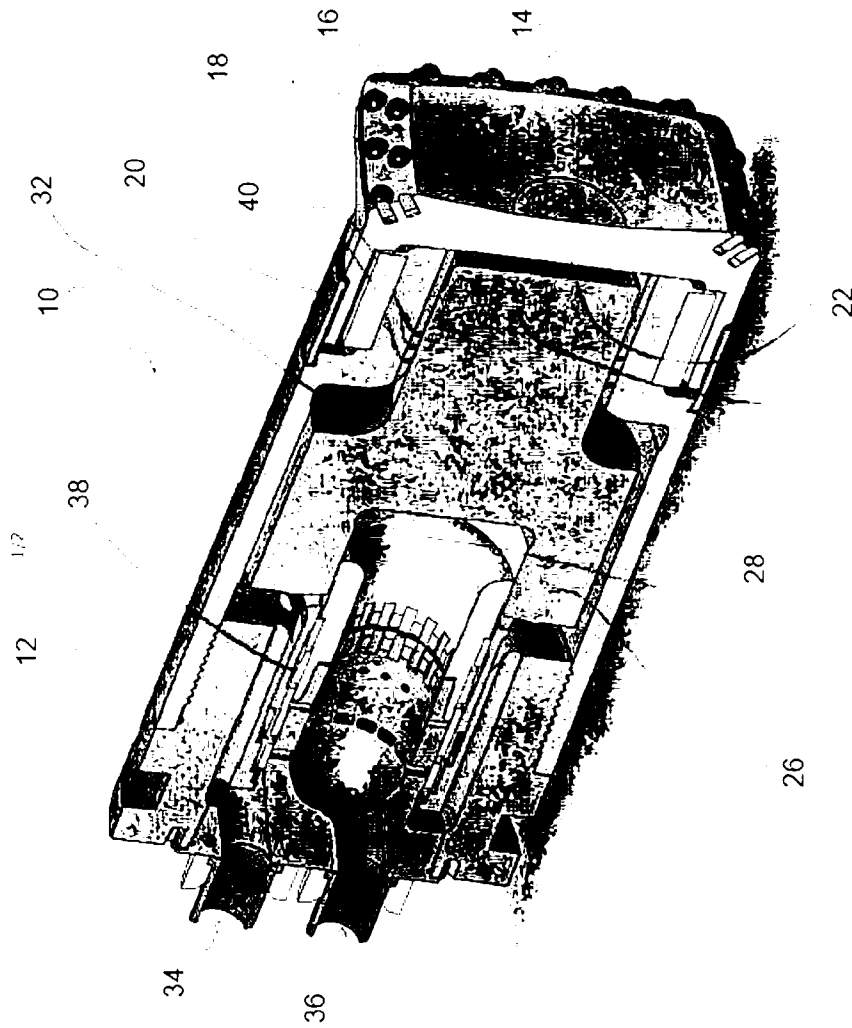

Figure 1 30

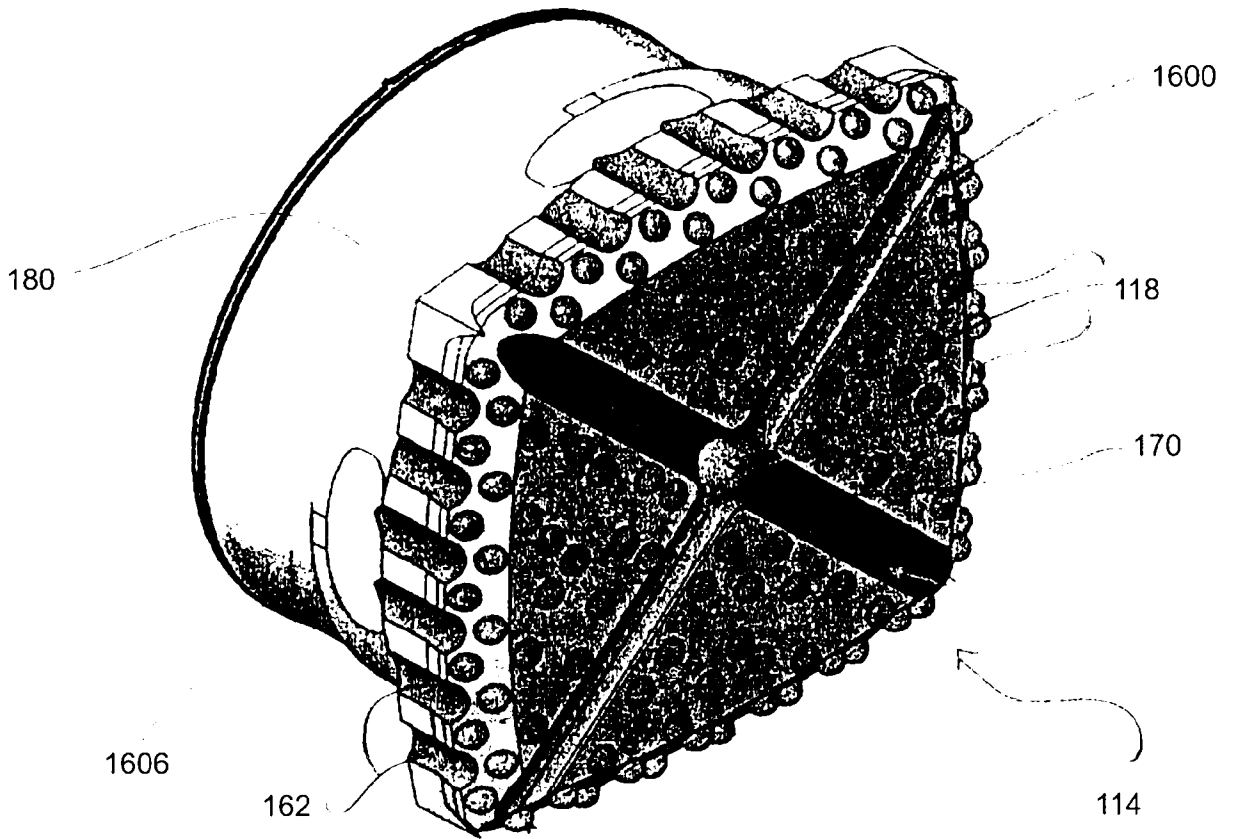

Figure 2A

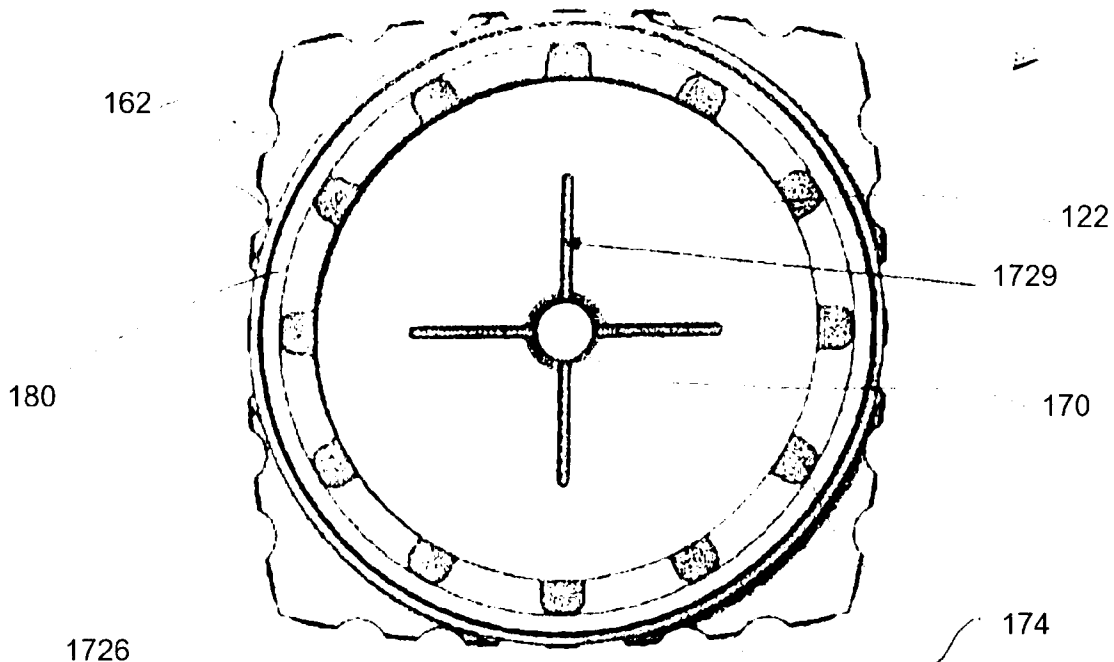

Figure 2B

## A. CLASSIFICATION OF SUBJECT MATTER

**E21B 4/14 (2006.01) E21B 4/16 (2006.01) E21D 9/10 (2006.01)**

According to International Patent Classification (IPC) or to both national classification and IPC

## B. FIELDS SEARCHED

Minimum documentation searched (classification system followed by classification symbols)

Documentation searched other than minimum documentation to the extent that such documents are included in the fields searched

Electronic data base consulted during the international search (name of data base and, where practicable, search terms used)

**Databases:** PATENW (logical database), DOCDB, DWPI, Google Search, Google Patents and IP Australia internal databases**IPC/CPC:** E21B4/[003,14,16], E21D1/06, E21D9/[10,106]**Search terms:** hammer, piston, impact, seal, O-ring, closed-circuit, cavity, liquid, fluid, water, hydraulic, liquid-free, rear, top, end, trailing, narrow, short, stroke, tunnel, TBM and like terms**Applicant/Inventor:** STRANGE, Warren

## C. DOCUMENTS CONSIDERED TO BE RELEVANT

Category*	Citation of document, with indication, where appropriate, of the relevant passages	Relevant to claim No.
Documents are listed in the continuation of Box C		

 Further documents are listed in the continuation of Box C See patent family annex

* Special categories of cited documents:		
"A" document defining the general state of the art which is not considered to be of particular relevance	"T" later document published after the international filing date or priority date and not in conflict with the application but cited to understand the principle or theory underlying the invention	
"D" document cited by the applicant in the international application	"X" document of particular relevance; the claimed invention cannot be considered novel or cannot be considered to involve an inventive step when the document is taken alone	
"E" earlier application or patent but published on or after the international filing date	"Y" document of particular relevance; the claimed invention cannot be considered to involve an inventive step when the document is combined with one or more other such documents, such combination being obvious to a person skilled in the art	
"L" document which may throw doubts on priority claim(s) or which is cited to establish the publication date of another citation or other special reason (as specified)	"&" document member of the same patent family	
"O" document referring to an oral disclosure, use, exhibition or other means		
"P" document published prior to the international filing date but later than the priority date claimed		

Date of the actual completion of the international search  
18 December 2020Date of mailing of the international search report  
18 December 2020**Name and mailing address of the ISA/AU**AUSTRALIAN PATENT OFFICE  
PO BOX 200, WODEN ACT 2606, AUSTRALIA  
Email address: pct@ipaustalia.gov.au**Authorised officer**Cohen Gray  
AUSTRALIAN PATENT OFFICE  
(ISO 9001 Quality Certified Service)  
Telephone No. +61262832749

<b>INTERNATIONAL SEARCH REPORT</b>		International application No.
C (Continuation). DOCUMENTS CONSIDERED TO BE RELEVANT		<b>PCT/AU2020/051060</b>
Category*	Citation of document, with indication, where appropriate, of the relevant passages	Relevant to claim No.
X	US 3903972 A (BOUYOUCOS et al.) 09 September 1975 Abstract; Figs. 1-2 and 4-7; Col. 3-7	1-16
Y	Abstract; Figs. 1-2 and 4-7	17-18
X	US 7152692 B2 (HURSKAINEN et al.) 26 December 2006 Abstract; Figs. 1-6; Col. 4-5	1-5 and 7-16
Y	Abstract; Figs. 1-6	17-18
A	WO 2016/148575 A1 (RESONATOR AS) 22 September 2016 Fig. 3; Pg. 4 and 10	5
Y	WO 2019/142000 A1 (STRADA DESIGN LIMITED) 25 July 2019 Abstract; Figs. 1-8; Pg. 10	17-18
Y	JP 2002-115490 A (JAPAN DRILLING CO LTD) 19 April 2002 Abstract; Figs. 1-2; [0018]	17-18

**INTERNATIONAL SEARCH REPORT**

Information on patent family members

International application No.

**PCT/AU2020/051060**

This Annex lists known patent family members relating to the patent documents cited in the above-mentioned international search report. The Australian Patent Office is in no way liable for these particulars which are merely given for the purpose of information.

<b>Patent Document/s Cited in Search Report</b>		<b>Patent Family Member/s</b>	
<b>Publication Number</b>	<b>Publication Date</b>	<b>Publication Number</b>	<b>Publication Date</b>
US 3903972 A	09 September 1975	US 3903972 A	09 Sep 1975
		AU 476939 B2	07 Oct 1976
		AU 8024575 A	07 Oct 1976
		CA 1018864 A	11 Oct 1977
		DE 2518240 A1	20 Nov 1975
		FR 2268573 A1	21 Nov 1975
		FR 2268573 B1	17 Oct 1980
		GB 1460556 A	06 Jan 1977
		JP S50148202 A	27 Nov 1975
		JP S5432987 B2	17 Oct 1979
		SE 405693 B	27 Dec 1978
		ZA 752428 B	31 Mar 1976
		US 7152692 B2	26 December 2006
US 7152692 B2	26 Dec 2006		
EP 1559515 A2	03 Aug 2005		
EP 1559515 B1	31 Oct 2012		
FI 20040156 A	03 Aug 2005		
FI 121139 B	30 Jul 2010		
JP 2005219203 A	18 Aug 2005		
JP 4795698 B2	19 Oct 2011		
KR 20050078653 A	05 Aug 2005		
KR 101160106 B1	26 Jun 2012		
WO 2016/148575 A1	22 September 2016	WO 2016148575 A1	22 Sep 2016
		NO 337771 B1	20 Jun 2016
		NO 20150341 A1	20 Jun 2016
WO 2019/142000 A1	25 July 2019	WO 2019142000 A1	25 Jul 2019
		GB 2570317 A	24 Jul 2019
JP 2002-115490 A	19 April 2002	JP 2002115490 A	19 Apr 2002

**End of Annex**