



HU000030556T2

(19) **HU**(11) Lajstromszám: **E 030 556**(13) **T2****MAGYARORSZÁG**
Szellemi Tulajdon Nemzeti Hivatala**EURÓPAI SZABADALOM**
SZÖVEGÉNEK FORDÍTÁSA(21) Magyar ügyszám: **E 11 702635**(51) Int. Cl.: **B65D 1/16** (2006.01)(22) A bejelentés napja: **2011. 02. 04.**

(86) A nemzetközi (PCT) bejelentési szám:

PCT/EP 11/051695

(96) Az európai bejelentés bejelentési száma:

EP 20110702635

(87) A nemzetközi közzétételi szám:

WO 11095613

(97) Az európai bejelentés közzétételi adatai:

EP 2531409 A1 2011. 08. 11.

(97) Az európai szabadalom megadásának meghirdetési adatai:

EP 2531409 B1 2016. 05. 11.

(30) Elsőbbségi adatok:

759298	2010. 04. 13.	US
10159582	2010. 04. 12.	EP
10159621	2010. 04. 12.	EP
10152593	2010. 02. 04.	EP

(73) Jogosult(ak):

Crown Packaging Technology, Inc., Alsip, IL
60803-2599 (US)

(72) Feltaláló(k):

PRESSET, Alain, Wantage oxfordshire OX12 9BP (GB)
MONRO, Stuart, Wantage oxfordshire OX12 9BP (GB)
VINCENT, Keith, Wantage oxfordshire OX12 9BP (GB)
RILEY, Jonathan, Wantage Oxfordshire OX12 9BP (GB)

(74) Képviselő:

SWORKS Nemzetközi Szabadalmi Ügyvivői
Iroda Kft., Budapest

(54)

Doboztest

Az európai szabadalom ellen, megadásának az Európai Szabadalmi Közlönyben való meghirdetésétől számított kilenc hónapon belül, felszólalást lehet benyújtani az Európai Szabadalmi Hivatalnál. (Európai Szabadalmi Egyezmény 99. cikk(1))

A fordítást a szabadalmas az 1995. évi XXXIII. törvény 84/H. §-a szerint nyújtotta be. A fordítás tartalmi helyességét a Szellemi Tulajdon Nemzeti Hivatala nem vizsgálta.

(19)



(11)

EP 2 531 409 B1

(12)

EUROPEAN PATENT SPECIFICATION

(45) Date of publication and mention of the grant of the patent:
11.05.2016 Bulletin 2016/19

(21) Application number: **11702635.1**

(22) Date of filing: **04.02.2011**

(51) Int Cl.:
B65D 1/16 (2006.01)

(86) International application number:
PCT/EP2011/051695

(87) International publication number:
WO 2011/095613 (11.08.2011 Gazette 2011/32)

(54) **CAN BODY**

DOSENKÖRPER

CORPS DE CANETTE

(84) Designated Contracting States:
AL AT BE BG CH CY CZ DE DK EE ES FI FR GB GR HR HU IE IS IT LI LT LU LV MC MK MT NL NO PL PT RO RS SE SI SK SM TR

(30) Priority: **13.04.2010 US 759298**
12.04.2010 EP 10159582
12.04.2010 EP 10159621
04.02.2010 EP 10152593

(43) Date of publication of application:
12.12.2012 Bulletin 2012/50

(73) Proprietor: **Crown Packaging Technology, Inc.**
Alsip, IL 60803-2599 (US)

(72) Inventors:
• **PRESSET, Alain**
Wantage oxfordshire OX12 9BP (GB)

- **MONRO, Stuart**
Wantage oxfordshire OX12 9BP (GB)
- **VINCENT, Keith**
Wantage oxfordshire OX12 9BP (GB)
- **RILEY, Jonathan**
Wantage Oxfordshire OX12 9BP (GB)

(74) Representative: **Lind, Robert**
Marks & Clerk LLP
Fletcher House
Heatley Road
The Oxford Science Park
Oxford OX4 4GE (GB)

(56) References cited:
EP-A1- 0 542 552 **BE-A1- 784 904**
GB-A- 2 286 364 **US-A- 3 561 638**
US-A- 4 341 321

EP 2 531 409 B1

Note: Within nine months of the publication of the mention of the grant of the European patent in the European Patent Bulletin, any person may give notice to the European Patent Office of opposition to that patent, in accordance with the Implementing Regulations. Notice of opposition shall not be deemed to have been filed until the opposition fee has been paid. (Art. 99(1) European Patent Convention).

Description

Technical Field

[0001] This invention relates to containers, and more particularly to metal containers for food, beverages, aerosols, and the like formed from a metal sheet.

Background Art

[0002] Two-piece metal containers for food and beverages are often manufactured by drawing and wall ironing (DWI, also referred to as drawing and ironing (D&I)) or drawing and re-drawing (DRD) processes. The term "two-piece" refers to i) a cup-like can body and ii) a closure that would be subsequently fastened to the open end of the can body to form the container.

[0003] In a conventional DWI (D&I) process (such as illustrated in figures 6 to 10 of United States Patent Number 4,095,544), a flat (typically) circular blank stamped out from a roll of metal sheet is drawn through a drawing die, under the action of a punch, to form a shallow first stage cup. This initial drawing stage does not result in any intentional thinning of the blank. Thereafter, the cup, which is typically mounted on the end face of a close fitting punch or ram, is pushed through one or more annular wall-ironing dies for the purpose of effecting a reduction in thickness of the sidewall of the cup, thereby resulting in an elongation in the sidewall of the cup. By itself, the ironing process will not result in any change in the nominal diameter of the first stage cup.

[0004] Figure 1 shows the distribution of metal in a container body resulting from a conventional DWI (D&I) process. Figure 1 is illustrative only, and is not intended to be precisely to scale. Three regions are indicated in figure 1, where:

- i. Region 1 represents the un-ironed material of the base. This remains approximately the same thickness as the ingoing gauge of the blank, i.e. it is not affected by the separate manufacturing operations of a conventional DWI process.
- ii. Region 2 represents the ironed mid-section of the sidewall. Its thickness (and thereby the amount of ironing required) is determined by the performance required for the container body.
- iii. Region 3 represents the ironed top-section of the sidewall. Typically in can making, this ironed top-section is around 50-75% of the thickness of the ingoing gauge.

[0005] In a DRD process (such as illustrated in figures 1 to 5 of US 4,095,544), the same drawing technique is used to form the first stage cup. However, rather than employing an ironing process, the first stage cup is then subjected to one or more re-drawing operations which act to progressively reduce the diameter of the cup and thereby elongate the sidewall of the cup. By themselves,

most conventional re-drawing operations are not intended to result in any change in thickness of the cup material. However, taking the example of container bodies manufactured from a typical DRD process, in practice there is typically some thickening at the top of the finished container body (of the order of 10% or more). This thickening is a natural effect of the re-drawing process and is explained by the compressive effect on the material when re-drawing from a cup of large diameter to one of smaller diameter.

[0006] Note that there are alternative known DRD processes which achieve a thickness reduction in the sidewall of the cup through use of small or compound radii draw dies to thin the sidewall by stretching in the draw and re-draw stages.

[0007] Alternatively, a combination of ironing and re-drawing may be used on the first stage cup, which thereby reduces both the cup's diameter and sidewall thickness. For example, in the field of the manufacture of two-piece metal containers (cans), the container body is typically made by drawing a blank into an intermediate, first stage cup and subjecting the cup to a number of re-drawing operations until arriving at a container body of the desired nominal diameter, then followed by ironing the sidewall to provide the desired sidewall thickness and height.

[0008] However, DWI (D&I) and DRD processes employed on a large commercial scale do not act to reduce the thickness (and therefore weight) of material in the base of the cup. In particular, drawing typically does not result in significant reduction in thickness of the object being drawn, and ironing only acts on the sidewalls of the cup. Essentially, for known DWI (D&I) and DRD processes for the manufacture of cups for two-piece containers, the thickness of the base remains relatively unchanged from that of the ingoing gauge of the blank. This can result in the base being far thicker than required for performance purposes.

[0009] Food, beverages, and other products are often packaged in two piece cans formed from aluminium, tin-plate steel, or coated steel sheets. Two piece cans include a can body having an integral base and sidewall and a lid that is seamed to the top of the sidewall of the can body.

[0010] Tin plate for can making typically is provided under ASTM A623 or ASTM A624 specifications. Even though most commercial tin plate is hot rolled or annealed late in the manufacturing process, often a surface cold rolling process provides an identifiable grain direction. The grains in commercial tin plate for can making are not equiaxed, but rather in a cross sectional sample define a longitudinal direction, which defines the grain direction, and a transverse direction. The grain boundaries are visible upon magnification by widely accepted techniques, such as described in ASTM E 112.

[0011] Aluminium for canmaking often begins as a sheet of 3104-H19 or 3004-H19 aluminium alloy, which is aluminium with approximately 1% manganese and 1% magnesium for strength and formability. The cold rolling

process used to produce commercial grade aluminium for canmaking yields a metal sheet having non-equiaxed grain structures. In this regard, aluminium sheet grains define a longitudinal direction and a transverse direction. Because of the amount of cold rolling, grains in commercial aluminium sheet for can making are elongated compared to grains in commercial tinplate for canmaking.

[0012] EP542 552 discloses a prior art can having an un-domed bottom, according to the preamble of appended claim 1.

[0013] There is a need for improved can technology and improved cans that make efficient and effective use of sheet material that takes advantage of economics of metal supply.

Disclosure of Invention

[0014] The present invention provides a can body according to independent claim 1 and associated method according to independent claim 5. A can body is formed from a process that includes a stretching operation on metal that becomes at least a portion of the base, and then drawing the stretched material radially outward, preferably into the sidewall. Subsequent ironing of the sidewall produces cans having desired base and wall thicknesses from thinner, less expensive sheet metal. In this regard, additional rolling steps need not be performed on the sheet metal at the mill, but the metal can be thinned during the can making process to achieve the desired attributes. Can bodies formed of this method may have attributes that are unlike cans made from less economical, thinner plate. For example, thickness reduction and distribution from raw sheet, hardness increase because of the stretching operation, and micrograin structure change due to stretching may be unique in the base of the can body formed from the disclosed method.

[0015] Such a drawn and ironed metal can body that is adapted for seaming onto a can end includes an ironed sidewall and an enclosed, un-domed base integrally formed with the sidewall. The bottom panel of the base (that is, the portion of the base within the peripheral countersink) has an average Rockwell hardness number between 64 and 70. The average is a numeric average of points taken through the centre and in the rolling direction. These hardness numbers are based on a process beginning with conventional, continuously annealed T4 plate having a starting hardness of 58. The present invention is not limited, however, to beginning with any particular plate thickness or hardness.

[0016] Preferably, the can body sidewall has an average thickness of between about 0,152 and 0,381 mm (about 0.006 inches and 0.015 inches), and the sidewall has a flange capable of being double seamed to a curl of a can end.

[0017] The can body base may have either (i) a Rockwell hardness that is at least approximately 65 or (ii) an average change in hardness from the raw sheet of at least 5 in Rockwell hardness number or (iii) an average

change in Rockwell hardness number from the raw sheet of at least 7%. Preferably, the increase in average Rockwell hardness number is between 5 and 17, and may also be between 6 and 15, or 7 and 12, or 8 and 10.

5 **[0018]** Preferably, the increase in average Rockwell hardness number, regardless of the starting sheet, is between 8% and 21%, and preferably between 10% and 16%, or between 12 and 15%. The sidewall of all the cans referred to in the summary section preferably has a thickness between approximately 0,102 and approximately 0,381 mm (approximately 0.004 and approximately 0.015 inches), and more preferably between approximately 0,102 and 0,178 mm (approximately 0.004 inches and 0.007 inches).

10 **[0018]** According to another embodiment or aspect of the present disclosure the can body base is formed from a sheet that is at least 0,381 mm (0,015 inches) thick and includes an ironed sidewall and a base integrally formed with the sidewall. The base includes a peripheral countersink and a substantially flat bottom panel having an average thickness between 0,152 and 0,381 mm (between 0.006 and 0.015 inches) and an average decrease in thickness from the raw sheet of at least 2%. Preferably the average decrease in thickness from the raw sheet is 25 between 5% and 30%, or between 10% and 25%. Preferably, the average bottom panel thickness is between 0,203 and 0,305 mm (between 0.008 and 0.012 inches), or between 0,203 and 0,254 mm (between 0.008 and 0.010 inches).

30 **[0019]** The can body base is un-domed and includes an ironed sidewall and a peripheral countersink and a bottom wall radially within the countersink. Grains in the base tinplate have an average aspect ratio of at least 1.4, preferably between 1.5 and 2.5, or between 1.6 and 2.2, 35 or approximately 1.8. Preferably the average aspect ratio is at least 20% greater than the average aspect ratio of raw sheet from which the can body is formed, and preferably between 20% and 100%, between 30% and 70%, or between 40% and 60% regardless of the starting sheet material.

Brief Description of Drawings

[0020]

45 Figure 1 is a side elevation view of a container body of the background art resulting from a conventional DWI process. It shows the distribution of material in the base and sidewall regions of the container body. 50 Figure 2 is a graph showing in general terms how the net overall cost of manufacturing a typical two-piece metal container varies with the ingoing gauge of the sheet metal. The graph shows how reducing the thickness of the sidewall region (e.g. by ironing) has the effect of driving down the net overall cost. 55 Figure 3 is a graph corresponding to figure 2, but based on actual price data for UK-supplied tinplate. Illustrations of aspects of the invention are illustrated

in the following drawings, with reference to the accompanying description:

Figure 4 is a graphical representation of the variation in base thickness of a cup resulting from use of a "stretch" punch (according to the invention) having a domed profiled end face.

Figure 5a is a side elevation view of the tooling of a cupping press used to form a first stage cup from a sheet metal blank. The figure shows the tooling before the initial drawing operation has commenced. Figure 5b corresponds to figure 5a, but on completion of the initial drawing operation to form the first stage cup.

Figure 6a is a side elevation view of a stretch rig used to perform the stretching operation of the invention. The figure shows the stretch rig before the stretching operation has commenced.

Figure 6b shows the stretch rig of figure 6a, but on completion of the stretching operation.

Figure 7 shows an alternative embodiment to that of figures 6a and 6b, in which the pre-stretched cup is clamped about its sidewall for the stretching operation.

Figure 8 shows an alternative embodiment of a stretch punch to that shown in figures 6a and 6b.

Figure 9 shows a further alternative embodiment of a stretch punch to those shown in figures 6a, 6b and 8, where the end face of the stretch punch includes various relief features.

Figures 10a-d show perspective views of a bodymaker assembly used to re-draw the stretched cup. The figures show the operation of the bodymaker from start to finish of the stretching operation.

Figure 11 shows a detail view of the re-draw die used in the bodymaker assembly of figures 10a-d.

Figure 12 shows the sheet metal blank at various stages during the method of the invention as it progresses from a planar sheet to a finished cup.

Figure 13a is a side elevation view of a stretch rig used to perform the stretching operation of the invention. The figure shows the stretch rig before the stretching operation has commenced.

Figure 13b shows the stretch rig of figure 13a, but on completion of the stretching operation.

Figure 14 shows an alternative embodiment of a stretch punch to that shown in figures 13a and 13b.

Figure 15 shows a further alternative embodiment of a stretch punch to that shown in figures 13a and 13b, where the end face of the stretch punch includes various relief features.

Figure 16 shows an expanse of metal sheet on which the stretching operation of the invention has been performed on a plurality of "enclosed portions" separated from each other and disposed across the area of the metal sheet.

Figures 17a and 17b show how, when performing the stretching operation to provide the stretched sheet shown in figure 16, any simultaneous stretch-

ing of two or more of the enclosed portions may be staggered to reduce the loads imposed on the tooling used.

Figure 18a is a side elevation view of the tooling of a cupping press used to perform an initial drawing stage of the drawing operation to form a cup from the stretched sheet metal. The figure shows the tooling before this initial drawing stage has commenced. Figure 18b corresponds to figure 18a, but on completion of the initial drawing stage.

Figure 19 shows a sheet metal blank at various stages during the method of the invention as it progresses from a planar sheet to a finished cup.

Figure 20 shows the use of the cup of the invention as part of a two-piece container.

Figure 21 is graph of hardness and thickness of a cup and an indication of the location of the measurements on the cup, formed according to an aspect of the present invention.

Figure 22 is a base of a can body formed from the cup shown in Figure 21, with numbered locations corresponding to the numbered locations shown in the cup of Figure 21.

Figure 23 is a micrograph of grain structure of a conventional cup and can body base.

Figure 24 is a micrograph of grain structure of a cup and can body base formed according to the present invention.

30 Mode(s) for Carrying Out the Invention

[0021] The following describes two example methods of forming a cup from which a can body according to the present invention may be formed, as well as the cup and can body. In the first method, a stretching operation is performed on a drawn cup, followed by a redrawing operation. In the second method, a stretching operation is performed on a flat blank, followed by a drawing operation. Preferably, a cup formed by either method is wall ironed into a finished can body. The present can body or finished can invention is not limited to the particular steps described below. Rather, the steps of producing the can structure are described to illustrate possible ways to achieve the attributes of the cup or can body. According to a first method of forming an intermediate cup, a cupping press 10 has a draw pad 11 and a draw die 12 (see figures 5a and 5b). A draw punch 13 is co-axial with the draw die 12, as indicated by common axis 14. A circumferential cutting element 15 surrounds the draw pad 11.

[0022] In use, a flat section of metal sheet 20 is held in position between opposing surfaces of the draw pad 11 and the draw die 12. Steel tin-plate (Temper 4) with an ingoing gauge thickness ($t_{in-going}$) of 0.280 mm has been used for the metal sheet 20. However, the invention is not limited to particular gauges or metals. The section of metal sheet 20 is typically cut from a roll of metal sheet (not shown). After the section of metal sheet 20 has been positioned, the circumferential cutting element 15 is

moved downwards to cut a circular planar blank 21 out from the metal sheet (see figure 5a). The excess material is indicated by 22 on figure 5a.

[0023] After the blank 21 has been cut from the sheet 20, the draw punch 13 is moved axially downwards through the draw die 12 to progressively draw the planar blank against the forming surface 16 of the draw die into the profile of a cup 23 having a sidewall 24 and integral base 25. This drawing operation is shown in figure 5b, and includes a separate view of the drawn cup 23 when removed from the press 10. A detail view is included in figure 5a of the radius R_{12} at the junction between the end face of the draw die 12 and its forming surface 16. As for conventional drawing operations, the radius R_{12} and the load applied by the draw pad 11 to the periphery of the blank 21 are selected to permit the blank to slide radially inwards between the opposing surfaces of the draw pad 11 and draw die 12 and along forming surface 16 as the draw punch 13 moves progressively downwards to draw the blank into the cup 23. This ensures that the blank 21 is predominantly *drawn*, rather than *stretched* (thinned) (or worse, torn about the junction between the end face of the draw die and the forming surface). Dependent on the size of radius R_{12} and, to a lesser extent, the severity of the clamping load applied by the draw pad 11, the wall thickness of the cup 23 will be essentially unchanged from that of the ingoing gauge of the blank 21, i.e. negligible stretching or thinning should occur. However, in alternative embodiments of the invention, it is permissible for the load applied by the draw pad 11 to be sufficient that a *combination* of drawing and stretching occurs under the action of the draw punch 13. The cup 23 that results from this initial drawing operation is also referred to the "first stage cup".

Stretching Operation, First Illustrative Method

[0024] Following the initial drawing operation shown in figures 5a and 5b, the drawn cup 23 is transferred to a stretch rig 30, an example of which is illustrated in figures 6a and 6b. The stretch rig 30 has two platens 31, 32 that are moveable relative to each other along parallel axes 33 under the action of loads applied through cylinders 34 (see figures 6a and 6b). The loads may be applied by any conventional means, e.g. pneumatically, hydraulically or through high-pressure nitrogen cylinders.

[0025] On platen 31 is mounted a stretch punch 35 and a clamping element in the form of an annular clamp ring 36. The annular clamp ring 36 is located radially outward of the stretch punch 35. The stretch punch 35 is provided with a domed end face (see figures 6a and 6b).

[0026] On platen 32 is amounted a cup holder 37. The cup holder 37 is a tubular insert having an annular end face 38 and an outer diameter corresponding to the internal diameter of the drawn cup 23 (see figures 6a and 6b). In use, the drawn cup 23 is mounted on the cup holder 37 so that the annular end face 38 contacts a corresponding annular region 26 of the cup's base 25

(see figures 6a and 6b). Loads are applied via cylinders 34 to move platens 31, 32 towards each other along axes 33 until the annular region 26 is clamped firmly in an annular manner between the planar surface of the clamp ring 36 and the annular end face 38 of the cup holder 37. The clamped annular region 26 defines an enclosed portion 27 of the cup. In the embodiment shown in figures 6a and 6b, the annular clamping thereby separates the base 25 into two discrete regions: the clamped annular region 26 and the enclosed portion 27.

[0027] The stretch punch 35 is then moved axially through the clamp ring 36 to progressively deform and stretch (thin) the enclosed portion 27 into a domed profile 28.

[0028] In the embodiment shown in the drawings, the enclosed portion 27 is domed inwardly 28 into the cup (see figure 6b). However, in an alternative embodiment, the enclosed portion 27 may instead be domed outwardly outside of the cup.

[0029] Ideally, the clamping loads applied during this stretching operation are sufficient to ensure that little or no material from the clamped annular region 26 (or the sidewall 24) flows into the enclosed portion 27 during stretching. This helps to maximise the amount of stretching and thinning that occurs in the domed region 28. However, as indicated above in the general description of the invention, it has been found that stretching and thinning of the enclosed portion 27 can still occur when permitting a limited amount of flow of material from the clamped annular region 26 (or from outside of the clamped region) into the enclosed portion.

[0030] In summary, this stretching operation and the resulting thinning of the base 25 is critical to achieving the object of the invention, namely to make a cup or container body having a base thickness which is less than that of the ingoing gauge of the metal sheet.

[0031] In an alternative embodiment shown in figure 7, the sidewall 24 rather than the base 25 is clamped during the stretching operation. Figure 7 shows an annular region 26 of the sidewall adjacent the base being clamped between cup holder 370 and clamping element 360. Either or both of the cup holder 370 and clamping element 360 may be segmented to facilitate the clamping of the sidewall, and to accommodate cups of different sizes. The annular clamping of the sidewall 24 defines an enclosed portion 27 inward of the clamped annular region 26 (see figure 7). A stretch punch 35 is also indicated in figure 7. Note that other features of the stretch rig are excluded from figure 7 for ease of understanding.

[0032] In a further alternative embodiment, the single stretch punch 35 is replaced by a punch assembly 350 (as shown in figure 8). The punch assembly 350 has:

- i) a first group 351 of an annular punch element 351a surrounding a central core punch element 351b; and
- ii) a second group 352 of an annular punch element 352a.

[0033] For ease of understanding, figure 8 only shows the punch assembly 350 and the drawn cup 23. Although not shown on figure 8, in use, an annular region 26 of the cup's base 25 would be clamped during the stretching operation in a similar manner to the embodiment shown in figures 6a and 6b.

[0034] In use, the first and second groups of punch elements 351, 352 face opposing surfaces of the enclosed portion 27. The stretching operation is performed by moving both first and second groups of punch elements 351, 352 towards each other to deform and stretch (thin) the enclosed portion 27. The enclosed portion 27 is deformed into an undulating profile 29 (see figure 8).

[0035] In a further embodiment, a single stretch punch 35 has a number of relief features in the form of recesses/cut-outs 353 provided in its end face (see figure 9). In the embodiment shown, there is a central recess/cut-out surrounded by a single annular recess/cut-out. However, alternative configurations of recess/cut-out may be used.

(Re-)Drawing Operation on Stretched Cup

[0036] For the embodiment of the invention shown in figures 6a and 6b, the stretched cup with its thinned and domed region 28 in the base is transferred to a body-maker assembly 40 (see figures 10a to 10d). The body-maker assembly 40 comprises two halves 41, 42 (indicated by arrows in figures 10a to 10d).

[0037] The first half 41 of the bodymaker assembly 40 has a tubular re-draw punch 43 mounted on the same axis as circumferential clamp ring 44. As can be seen from figures 10a to 10d, the clamp ring 44 circumferentially surrounds the re-draw punch 43 like a sleeve. As will be understood from the following description and looking at figures 10a to 10d, the re-draw punch 43 is moveable through and independently of the circumferential clamp ring 44.

[0038] The second half 42 of the body-maker assembly 40 has a re-draw die 45. The re-draw die 45 has a tubular portion having an outer diameter corresponding to the internal diameter of the stretched cup 23 (see figure 10a). The re-draw die 45 has a forming surface 46 along its inner axial surface, which terminates in an annular end face 47 (see figures 10a to 10d). The annular end face 47 of the re-draw die 45 corresponds in width to that of the annular region 26 of the base of the stretched cup.

[0039] In use, the stretched cup 23 is first mounted on the re-draw die 45 (as shown on figure 10a). Then, as shown in figure 10b, the two halves 41, 42 of the body-maker assembly 40 are moved axially relative to each other so that the annular region 26 of the base of the stretched cup is clamped between the annular end face 47 of the re-draw die 45 and the surface of the circumferential clamp ring 44.

[0040] Once clamped, the re-draw punch 43 is then forced axially through the clamp ring 44 and the re-draw die 45 (see arrow A on figures 10c and 10d) to progressively re-draw the material of the stretched cup along the

forming surface 46 of the re-draw die. The use of the re-draw die 45 has two effects:

- i. to cause material from the sidewall 24 to be drawn radially inwards and then axially along the forming surface 46 of the re-draw die 45 (as indicated by arrows B on figures 10c and 10d). In this way, the cup is reduced in diameter (as indicated by comparing figure 10a with figure 10d); and
- ii. to cause the stretched and thinned material in the domed region 28 of the base to be progressively pulled out and transferred from the base into the reduced diameter sidewall (as indicated by arrows C on figures 10c and 10d). This has the effect of flattening the domed region 28 of the base (see especially figure 10d).

[0041] Figure 10d shows the final state of the re-drawn cup 23 when the re-draw punch 43 has reached the end of its stroke. It can clearly be seen that the formerly domed region 28 of the base has been pulled essentially flat, to provide a cup or container body 23 where the thickness of the base 25 is thinner than that of the ingoing blank 21. As stated earlier, this reduced thickness in the base 25 - and the consequent weight reduction - is enabled by the stretching operation performed previously.

[0042] As shown in the detail view of the re-draw die 45 in figure 11, the junction between the forming surface 46 and the annular end face 47 of the re-draw die is provided with a radius R_{45} in the range 1 to 3.2 mm. The provision of a radius R_{45} alleviates the otherwise sharp corner that would be present at the junction between the forming surface 46 and the annular end face 47, and thereby reduces the risk of the metal of the stretched cup 23 tearing when being re-drawn around this junction.

[0043] Note that although figures 10a to 10d show use of a tubular re-draw punch 43 having an annular end face, the punch may alternatively have a closed end face. The closed end face may be profiled to press a corresponding profile into the base of the cup.

[0044] The drawing operation described above and illustrated in figures 10a to 10d is known as reverse re-drawing. This is because the re-draw punch 43 is directed to invert the profile of the stretched cup. In effect, the re-draw punch reverses the direction of the material and turns the stretched cup inside out. This can be seen by comparing the cup profiles of figures 10a and 10d. Reverse re-drawing the cup in this context has the advantages of:

- i. preventing uncontrolled buckling of the domed region 28 of the base of the stretched cup (especially when using a re-draw punch having a closed end face); and
- ii. maximising transfer of material from the domed region 28 to the sidewalls 24.

[0045] Note that although the embodiment shown in

figures 10a to 10d illustrates reverse re-drawing, conventional re-drawing would also work; i.e. where the re-draw punch acts in the opposite direction to reverse re-drawing and does not turn the cup inside out.

[0046] Figure 12 shows the changes undergone by the metal blank 21 from:

- a) before any forming operations have been undertaken; to
- b) forming into the first stage cup in the cupping press 10; to
- c) the stretching and thinning operation performed in the stretch rig 30; to
- d) the re-drawn cup that results from the bodymaker assembly 40.

[0047] A location on the domed region 28 of the stretched cup is indicated as X on figure 12. The figure illustrates the effect of the re-drawing operation in radially pulling out X to X'. The figure shows that the base of the cup at that location after stretching (t_{stretch}) (and after the re-drawing operation) has a reduced thickness relative to the ingoing gauge of the blank 21 ($t_{\text{in-going}}$), i.e. $t_{\text{stretch}} < t_{\text{in-going}}$. As previously stated, this thinning of the base is enabled by the stretching operation.

[0048] To maximise the height of the sidewall 24 of the cup with its thinned base, the re-drawn cup may also undergo ironing of the sidewalls by being drawn through a succession of ironing dies (not shown). This ironing operation has the effect of increasing the height and decreasing the thickness of the sidewall, and thereby maximising the enclosed volume of the cup.

Stretching Operation, Second Illustrative Method

[0049] According to a second method of forming the intermediate cup that is shown in Figures 6a and 6b, a flat section of metal sheet 10' is located within a stretch rig 20' (an example of which is illustrated in figures 13a and 13b). Steel tin-plate (Temper 4) with an ingoing gauge thickness ($t_{\text{in-going}}$) of 0.280 mm has been used for the metal sheet 10'. However, the invention is not limited to particular gauges or metals. The section of metal sheet 10' is typically cut from a roll of metal sheet (not shown). The stretch rig 20' has two platens 21', 22' that are moveable relative to each other along parallel axes 23' under the action of loads applied through cylinders 24' (see figures 13a and 13b). The loads may be applied by any conventional means, e.g. pneumatically, hydraulically or through high-pressure nitrogen cylinders.

[0050] On platen 21' is mounted a stretch punch 25' and a clamping element in the form of a first clamp ring 26'. The first clamp ring 26' is located radially outward of the stretch punch 25'. The stretch punch 25' is provided with a domed end face (see figures 13a and 13b).

[0051] On platen 22' is mounted a second clamp ring 27'. The second clamp ring 27' is a tubular insert having an annular end face 28' (see figures 13a and 13b). In

use, loads are applied via the cylinders 24' to move platens 21', 22' towards each other along axes 23' until the flat section of metal sheet 10' is clamped firmly in an annular manner between the first and second clamp rings 26', 27' to define a clamped annular region 15' on the section of metal sheet. The clamped annular region 15' defines an enclosed portion 16' on the metal sheet 10'.

[0052] The stretch punch 25' is then moved axially through the first clamp ring 26' to progressively deform and stretch (thin) the metal of the enclosed portion 16' into a domed profile 17' (see figure 13b).

[0053] Ideally, the clamping loads applied during this stretching operation are sufficient to ensure that little or no material from the clamped annular region 15' flows into the enclosed portion 16' during stretching. This helps to maximise the amount of stretching and thinning that occurs in the enclosed portion 16'. However, as indicated above in the general description of the invention, it has been found that stretching and thinning of the metal of the enclosed portion 16' can still occur when permitting a limited amount of flow of metal from the clamped annular region 15' (or from outside of the clamped region) into the enclosed portion.

[0054] In an alternative embodiment, the single stretch punch 25' is replaced by a punch assembly 250' (as shown in figure 14). The punch assembly 250' has:

- i. a first group 251' of an annular punch element 251 a' surrounding a central core punch element 251 b'; and
- ii. a second group 252' of an annular punch element 252a'.

[0055] For ease of understanding, figure 14 only shows the punch assembly 250' and the section of metal sheet 10'. Although not shown on figure 14, in use an annular region 15' of the metal sheet 10' would be clamped during the stretching operation in a similar annular manner to the embodiment shown in figures 13a and 13b.

[0056] In use, the first and second groups of punch elements 251', 252' face opposing surfaces of the enclosed portion 16' of the metal sheet 10'. The stretching operation is performed by moving both first and second groups of punch elements 251', 252' towards each other to deform and stretch (thin) the metal of the enclosed portion 16'. The enclosed portion 16' is deformed into an undulating profile 170' (see figure 14).

[0057] In a further embodiment, a single stretch punch 25' has a number of relief features in the form of recesses/cut-outs 253' provided in its end face (see figure 15). In the embodiment shown in figure 15, there is a central recess/cut-out surrounded by a single annular recess/cut-out. However, alternative configurations of recess/cut-out may be used.

[0058] The embodiment in figures 13a and 13b is shown punching a single enclosed portion in a section of metal sheet 10'. However, the apparatus shown in figures 13a and 13b can be used to stretch and thin a plurality

of enclosed portions 16' separated from each other and disposed across the area of the metal sheet 10'. Figure 16 shows the section of metal sheet 10' having undergone such a stretching operation to define a number of stretched and thinned domed enclosed portions 16', 17' disposed across the area of the sheet. Whilst this be done using a single stretch punch performing a number of successive stretching operations across the area of the metal sheet 10', it is preferred that the apparatus includes a plurality of stretch punches which allow simultaneous stretching operations to be performed on a corresponding number of enclosed portions disposed across the area of the metal sheet. However, to reduce the loads imposed on the tooling used for stretching, it is beneficial to stagger any simultaneous stretching operations so that not all of the enclosed portions across the sheet are stretched at the same time. Figures 17a and 17b indicate six groups of enclosed portions - 'a', 'b', 'c', 'd', 'e' and 'f'. In use, all the enclosed portions in each group would be stretched simultaneously. In the embodiment shown in figure 17a, the stretching would progress radially outwardly from group 'a', to group 'b', to group 'c', to group 'd', to group 'e', to group 'f'. In the alternative embodiment shown in figure 17b, the stretching would progress radially inwardly from group 'f', to group 'e', to group 'd', to group 'c', to group 'b', to group 'a'. On completion of the stretching, separate blanks would be cut from the stretched metal sheet for subsequent drawing.

[0059] Note that figures 16, 17a and 17b are illustrative only and are not intended to be to scale.

Initial Drawing Stage of Drawing Operation, Second Illustrative Method

[0060] On completion of the stretching operation, the metal sheet 10' with its stretched and thinned domed enclosed portion 16', 17' is moved to a cupping press 30'. The cupping press 30' has a draw pad 31' and a draw die 32' (see figures 18a and 18b). A draw punch 33' is co-axial with the draw die 32', as indicated by common axis 34'. The draw punch 33' is provided with a recess 35'. A circumferential cutting element 36' surrounds the draw pad 31'.

[0061] In use, the section of metal sheet 10' is held in position between opposing surfaces of the draw pad 31' and the draw die 32'. The sheet 10' is located so that the domed enclosed portion 16', 17' is centrally located above the bore of the draw die 32'. After the metal sheet 10' has been positioned, the circumferential cutting element 36' is moved downwards to cut a blank 11' out from the metal sheet 10' (see figure 18a). The excess material is indicated by 12' on figure 18a.

[0062] After the blank 11' has been cut from the sheet 10', the draw punch 33' is moved axially downwards into contact with the blank 11' (see figure 18b). The draw punch 33' first contacts the blank 11' on an annular region 18a' located adjacent and radially outward of the domed enclosed portion 16', 17' (see figure 18a). The recess 35'

provided in the draw punch 33' avoids crushing of the domed enclosed portion 16', 17' during drawing. The draw punch 33' continues moving downwardly through the draw die 32' to progressively draw the blank 11' against the forming surface 37' of the die into the profile of a cup 19' having a sidewall 19'_{sw} and integral base 19'_b. However, the action of the draw punch 33' against the blank 11' also causes material of the domed enclosed portion 16', 17' to be pulled and transferred outwardly (as indicated by arrows D in figure 18b). This initial drawing stage results in a reduction in height of the domed region due to its material having been drawn outwardly. Dependent on the depth of the draw, the drawing may be sufficient to pull and transfer some of the stretched and thinned material of the domed enclosed portion 16', 17' into the sidewall 19'_{sw} during this initial drawing stage, rather than this stretched and thinned material remaining wholly within the base 19'_b. Figure 18b includes a separate view of the drawn cup 19' that results from use of the cupping press 30', with the reduced height domed region in the base indicated by 17''. A detail view is included in figure 18a of the radius R'₃₂ at the junction between the end face of the draw die 32' and its forming surface 37'. As for conventional drawing operations, the radius R'₃₂ and the load applied by the draw pad 31' to the periphery of the blank 11' are selected to permit the blank to slide radially inwards between the opposing surfaces of the draw pad 31' and draw die 32' and along forming surface 37' as the draw punch 33' moves progressively downwards to draw the blank into the cup 19'. This ensures that the blank 11' is predominantly drawn, rather than stretched (thinned) (or worse, torn about the junction between the end face of the draw die and the forming surface 37'). Dependent on the size of radius R'₃₂ and, to a lesser extent, the severity of the clamping load applied by the draw pad 31', negligible stretching or thinning should occur during this initial drawing stage. However, in alternative embodiments of the invention, it is permissible for the load applied by the draw pad 31' to be sufficient that a combination of drawing and further stretching occurs under the action of the draw punch 33'. The cup 19' that results from this initial drawing stage is also referred to the "first stage cup".

[0063] In an alternative embodiment of the invention not shown in figures 18a and 18b, if the depth of draw were sufficient it would result in the domed enclosed portion 16', 17' being pulled essentially flat in this initial drawing stage to define a cup 19' having an essentially flat base 19'_b.

[0064] The first stage cup 19' resulting from the cupping process shown in figures 18a and 18b and described above is transferred to a bodymaker assembly 40, where re-drawing processes may be performed as previously described with respect to stretched cup 23.

[0065] Figure 19 shows the changes undergone by the metal sheet 10' from before any forming operations have been undertaken (view a), to after the stretching operation in the stretch rig 20' (view b), to after the initial drawing

stage in the cupping press 30' (view c), and finally to after the re-drawing stage in the bodymaker assembly 40 (view d). The figures clearly show that the base of the final cup has a reduced thickness (t_{stretch}) relative to the ingoing gauge of the metal sheet 10' ($t_{\text{in-going}}$), i.e. $t_{\text{stretch}} < t_{\text{in-going}}$. As previously stated, this reduced thickness (relative to the ingoing gauge of the metal sheet) is enabled by the stretching process of the invention. The effect of the initial drawing stage in progressively pulling and transferring outward material of the domed enclosed portion 16', 17' is shown on views b and c of figure 19, with material at location X pulled and transferred outward to location X' as a result of the initial drawing stage. The effect of the re-drawing stage is shown in view d of figure 19, with material at location X' pulled and transferred to location X'' in the sidewall 19'_{sw}.

[0066] To maximise the height of the sidewall 19'_{sw} of the cup with its thinned base, the cup may also undergo ironing of the sidewalls by being drawn through a succession of ironing dies (not shown) in an ironing operation. This ironing operation has the effect of increasing the height and decreasing the thickness of the sidewall.

[0067] Figure 20 is a schematic view of a container 100 where either the final resulting cup 19' (or stretched cup 23) serves as container body 110. Preferably, the cup 19' (or stretched cup 23) undergoes a conventional ironing process (not shown in the figures) to achieve a desired sidewall thickness. The container body 110 is flared outwardly into a flange 111 at its access opening. Can end 120 is provided with a seaming panel 121 that enables the can end to be fastened to the container body by seaming to flange 111. For discussion of the cup or can body, the term "intermediate cup" refers to cups, such as 19' or 23, that may be formed from the above methods, and the term "can body" refers to the structure of the cup after an ironing process.

[0068] Figure 21 is a graph of material thickness distribution and Rockwell hardness distribution of a stretched cup 123, which was prepared according to the first method (cup stretching) described above from conventional tin plate (that is, continuously annealed, T4) of 0,2794 mm (0.0110 inch) thickness. Figure 22 shows a cross section of a can body base 124 after re-drawing and ironing processes. The locations labelled on base 124 correspond to the locations labelled on cup 123 shown in Figure 21.

[0069] Base 124 includes a relatively planar, un-beaded central panel 130 at its centre, a boss or recess 132 surrounding bottom panel 130, and a peripheral bead 134. Panel 130, recess 132, and bead 134 together form a bottom panel 140. Bead 134 yields to an inboard wall of a countersink bead 134, the bottom of which forms a standing surface on which the can body rests. The upper wall of bead 134 preferably smoothly yields to the can body sidewall. As bottom panel 140 is relatively unstructured, base 124 may be considered to be un-domed.

[0070] The following information describes the cup 123 and the base 124 of the can body according to attributes

of thickness distribution, hardness distribution, and micro-grain structure. Each thickness, hardness, and grain aspect ratio value provided herein depends on the incoming sheet thickness, hardness, annealing, chemistry, and the like, and depending on the desired attributes of the container, degree of re-drawing desired, end goal of the container, and other well-known parameters. For the thickness and hardness distributions, measurements are taken radially from the centre along the grain direction, which is apparent from rolling marks on the sheet. The values and ranges for thickness, hardness, and grain aspect ratio provided herein apply to the can body before any baking or ovening process, but also to the finished can body that is seamed together with an end.

[0071] As illustrated in Figure 21, the thickness of cup 123 monotonically decreases from 0,2464 mm (0.0097 inches) from the centre at point zero to 0,2413 mm (0.0095 inches) at point 3, and increases until point 8 near the boundary of the stretched region of the cup. The numeric average thickness of the stretched base from centre point zero to point 9 (near the stretched dome edge) is 0,2515 mm (0.0099 inches) (an average thickness reduction of 9.8%), and an average thickness of the stretched base of point zero through point 6 (that is, bottom panel 140) is 0,2438 mm (0.0096 inches) (an average wall thickness reduction of 12.2%).

[0072] The inventors surmise that either can bottom panels or the overall stretched portion of the cup, when formed of conventional tinplate, such as CA, T4 plate, having a starting thickness of approximately 0,279 or 0,292 mm (0.011 or 0.0115 inches), can be formed in a thickness range of between 0,152 and 0,381 mm (between 0.006 and 0.015 inches), more preferably between 0,203 and 0,254 mm (between 0.008 and 0.010 inches). Thickness reductions of at least 2%, preferably between 5% and 30%, more preferably between 10% and 25% are contemplated.

[0073] As expected because of work hardening relating to the stretching process, the hardness values inversely correlate to the thickness values. The incoming raw sheet Rockwell hardness number of 58 (RH T-30) is significantly increased throughout the stretched region of points 0 through 9 to a minimum number of 63 (an increase of 8.6%) and an average number of 66 (an increase of 13.8%). For bottom panel 140, the minimum hardness number is 65 (an increase of 12.1%) and the average hardness number is 66.7 (an increase of 15.0%).

[0074] The inventors surmise that a hardness number throughout can bottom 140 may be achieved of at least 63, preferably between 63 and 75, and more preferably between 64 and 70. Moreover, the inventors surmise that the average hardness number of can bottom 140 preferably is at least 64, preferably 64 to 70, and more preferably 68. An increase in average hardness number of can bottom 140 from incoming raw sheet of at least 5 on the RH scale, and more particularly between 5 and 17, between 6 and 15, between 7 and 12, and between 8 and 10, is believed to be achievable and beneficial. The in-

crease in average RH number of can bottom 140 is at least 7%, preferably between 8% and 21%, more preferably between 10% and 16%, and more preferably between 12% and 15%. As shown in Figure 21, the increase in average Rockwell Hardness number in the example is approximately 8 over the entire stretched cup, and 8.7 in bottom plate 140.

[0075] Figures 23 and 24 are photomicrographs of a polished and etched can cross section taken at or near the centre of the respective can bottoms, in general accordance with ASTM E 112 and according to industry practice. Figure 23 shows a cross section of a drawn and ironed can formed of conventional tinplate (CA, T4). Because conventional DWI processes do not appreciably work the bottom centre of the can, the micrograph of Figure 23 is believed to be very close to the structure of incoming raw sheet. Figure 24 shows a cross section of a can formed according to the methods described above.

[0076] Upon preparing the samples to identify grain boundaries, an aspect ratio of the grains may be identified by measuring the grain length in the rolling direction (that is, horizontally in the orientation of Figures 23 and 24) and dividing it by the grain dimension perpendicular to the rolling direction (that is, vertically in the orientation of Figures 23 and 24). The inventors surmise that the average grain aspect ratio of a can body formed according to the present invention taken at the bottom centre of the centre panel (corresponding to point zero in Figure 22) is at least 1.4, preferably between 1.5 and 2.5, more preferably between 1.6 and 2.2. In the example of Figure 24, the average aspect ratio is about 1.8. The inventors surmise can body 124 will have an increase (compared with raw sheet) of at least 20%, preferably between 20% and 100%, more preferably between 30% and 70%, and more preferably between 40% and 60%. The averages may be taken by choosing representative grains.

Claims

1. A drawn and ironed metal can body (110) adapted for seaming onto a can end (120), the can body (110) comprising: an ironed sidewall having a flange (111) capable of being double seamed to a curl of a can end; and an un-domed, enclosed base (124) integrally formed with the sidewall, the base (124) including a peripheral countersink (134) and a bottom wall (130) radially within the countersink (134), **characterised in that** the average Rockwell hardness number of the can body is between 64 and 70, the base has been work hardened by stretching, and grains in the base tinplate have an average aspect ratio of at least 1.4.
2. The can body of claim 1 wherein grains in the base tinplate have the average aspect ratio between 1.5 and 2.5.

3. The can body of claim 1 or claim 2, wherein grains in the base tinplate have the average aspect ratio between 1.6 and 2.2.
4. The can body of claim 3, wherein grains in the base tinplate have an average aspect ratio of approximately 1.8.
5. A method of manufacture of a drawn and ironed metal can body (110) adapted for seaming onto a can end (120), the can body (110) comprising:
 - an ironed sidewall having a flange (111) capable of being double seamed to a curl of a can end; and
 - an un-domed, enclosed base (124) integrally formed with the sidewall,
 - characterised in that** the base (124) is work hardened by stretching from a raw metal sheet (10) which results in an average change in Rockwell hardness number from the raw sheet of at least 7%.
6. The method of manufacture of a drawn and ironed metal can body (110) of claim 5, wherein the increase in average Rockwell hardness number is between 8% and 21 %.
7. The method of manufacture of a drawn and ironed metal can body (110) of claim 5 or claim 6, wherein the increase in average Rockwell hardness number is between 10% and 16%.
8. The method of manufacture of a drawn and ironed metal can body (110) of any one of claims 5 to 7, wherein the increase in average Rockwell hardness number is between 12 and 15%.

40 Patentansprüche

1. Gezogener und streckgezogener Metall-Dosenkörper (110), der zum Falzen auf ein Dosenende (120) eingerichtet ist, wobei der Dosenkörper (110) Folgendes umfasst:
 - eine streckgezogene Seitenwand, die einen Flansch (111) hat, der dafür eingerichtet ist, doppelt an eine Bördelung eines Dosenendes gefalzt zu werden, und
 - eine nicht gewölbte, umschlossene Basis (124), die integral mit der Seitenwand geformt ist, wobei die Basis (124) eine umlaufende Kegelsenkung (134) und eine Bodenwand (130), radial innerhalb der Kegelsenkung (134), einschließt, **dadurch gekennzeichnet, dass** die durchschnittliche Rockwell-Härtezahl des Dosenkörpers zwischen 64 und 70 beträgt, die Basis

- durch Strecken kaltgehärtet worden ist und Körner in dem Basis-Weißblech ein durchschnittliches Seitenverhältnis von wenigstens 1,4 haben.
2. Dosenkörper nach Anspruch 1, wobei Körner in dem Basis-Weißblech das durchschnittliche Seitenverhältnis zwischen 1,5 und 2,5 haben.
 3. Dosenkörper nach Anspruch 1 oder Anspruch 2, wobei Körner in dem Basis-Weißblech das durchschnittliche Seitenverhältnis zwischen 1,6 und 2,2 haben.
 4. Dosenkörper nach Anspruch 3, wobei Körner in dem Basis-Weißblech ein durchschnittliches Seitenverhältnis von ungefähr 1,8 haben.
 5. Verfahren zur Fertigung eines gezogenen und streckgezogenen Metall-Dosenkörpers (110), der zum Falzen auf ein Dosenende (120) eingerichtet ist, wobei der Dosenkörper (110) Folgendes umfasst:
 - eine streckgezogene Seitenwand, die einen Flansch (111) hat, der dafür eingerichtet ist, doppelt an eine Bördelung eines Dosenendes gefalzt zu werden, und
 - eine nicht gewölbte, umschlossene Basis (124), die integral mit der Seitenwand geformt ist, **dadurch gekennzeichnet, dass** die Basis (124) durch Strecken aus einem rohen Metallblech (10) kaltgehärtet worden ist, was zu einer durchschnittlichen Veränderung bei der Rockwell-Härtezah von dem rohen Blech von wenigstens 7 % führt.
 6. Verfahren zur Fertigung eines gezogenen und streckgezogenen Metall-Dosenkörpers (110) nach Anspruch 5, wobei die Zunahme bei der durchschnittlichen Rockwell-Härtezah zwischen 8 % und 21 % beträgt.
 7. Verfahren zur Fertigung eines gezogenen und streckgezogenen Metall-Dosenkörpers (110) nach Anspruch 5 oder Anspruch 6, wobei die Zunahme bei der durchschnittlichen Rockwell-Härtezah zwischen 10 % und 16 % beträgt.
 8. Verfahren zur Fertigung eines gezogenen und streckgezogenen Metall-Dosenkörpers (110) nach einem der Ansprüche 5 bis 7, wobei die Zunahme bei der durchschnittlichen Rockwell-Härtezah zwischen 12 % und 15 % beträgt.

Revendications

1. Corps de canette en métal embouti et étiré (110) adapté à être agrafé sur un couvercle (120), le corps de canette (110) comprenant: une paroi latérale étirée présentant une bride (111) apte à être doublement agrafée sur un bord roulé d'un couvercle ; et une base incorporée non bombée (124) formée d'un seul tenant avec la paroi latérale, la base (124) comportant un creux périphérique (134) et une paroi de fond (130) située radialement vers l'intérieur du creux (134), **caractérisé en ce que** le nombre moyen de dureté Rockwell du corps de canette se situe entre 64 et 70, la base a été écrouie par traction et les grains du fer-blanc de la base ont un rapport d'aspect moyen d'au moins 1,4.
2. Corps de canette selon la revendication 1, dans lequel les grains du fer-blanc de la base ont un rapport d'aspect moyen situé entre 1,5 et 2,5.
3. Corps de canette selon la revendication 1 ou la revendication 2, dans lequel les grains du fer-blanc de la base ont un rapport d'aspect moyen situé entre 1,6 et 2,2.
4. Corps de canette selon la revendication 3, dans lequel les grains du fer-blanc de la base ont un rapport d'aspect moyen d'environ 1,8.
5. Procédé de fabrication d'un corps de canette en métal embouti et étiré (110) adapté à être agrafé sur un couvercle (120), le corps de canette (110) comprenant :
 - une paroi latérale étirée présentant une bride (111) apte à être doublement agrafée sur un bord roulé d'un couvercle ; et
 - une base incorporée non bombée (124) formée d'un seul tenant avec la paroi latérale, **caractérisé en ce que** la base (124) est écrouie par traction à partir d'un feuillard brut (10), produisant une modification moyenne du nombre de dureté Rockwell par rapport à celui du feuillard brut d'au moins 7 %.
6. Procédé de fabrication d'un corps de canette en métal embouti et étiré (110) selon la revendication 5, dans lequel l'augmentation du nombre moyen de dureté Rockwell se situe entre 8 % et 21 %.
7. Procédé de fabrication d'un corps de canette en métal embouti et étiré (110) selon la revendication 5 ou la revendication 6, dans lequel l'augmentation du nombre moyen de dureté Rockwell se situe entre 10 % et 16 %.

8. Procédé de fabrication d'un corps de canette en métal embouti et étiré (110) selon l'une quelconque des revendications 5 à 7, dans lequel l'augmentation du nombre moyen de dureté Rockwell se situe entre 12 % et 15 %.

5

10

15

20

25

30

35

40

45

50

55

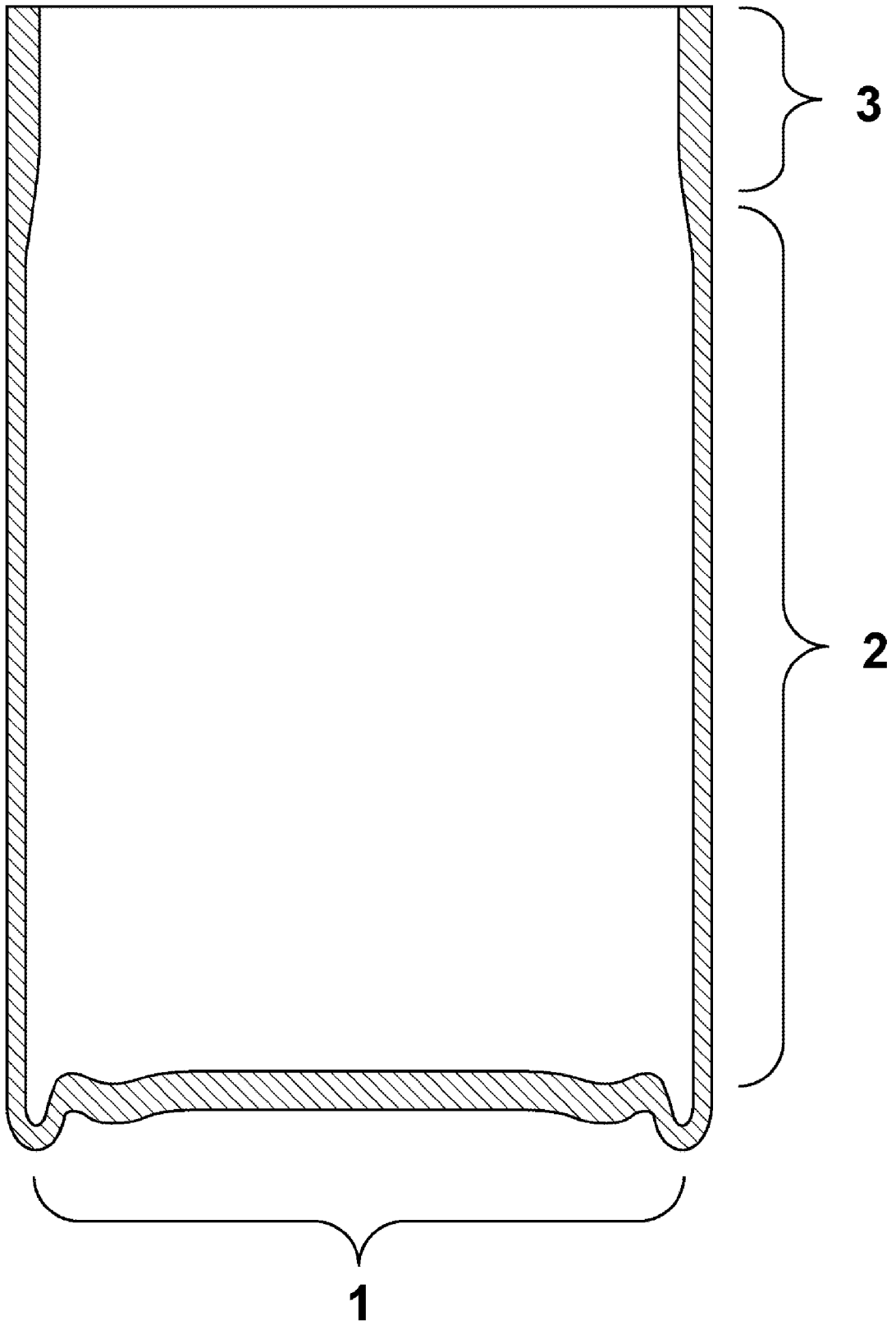

Figure 1

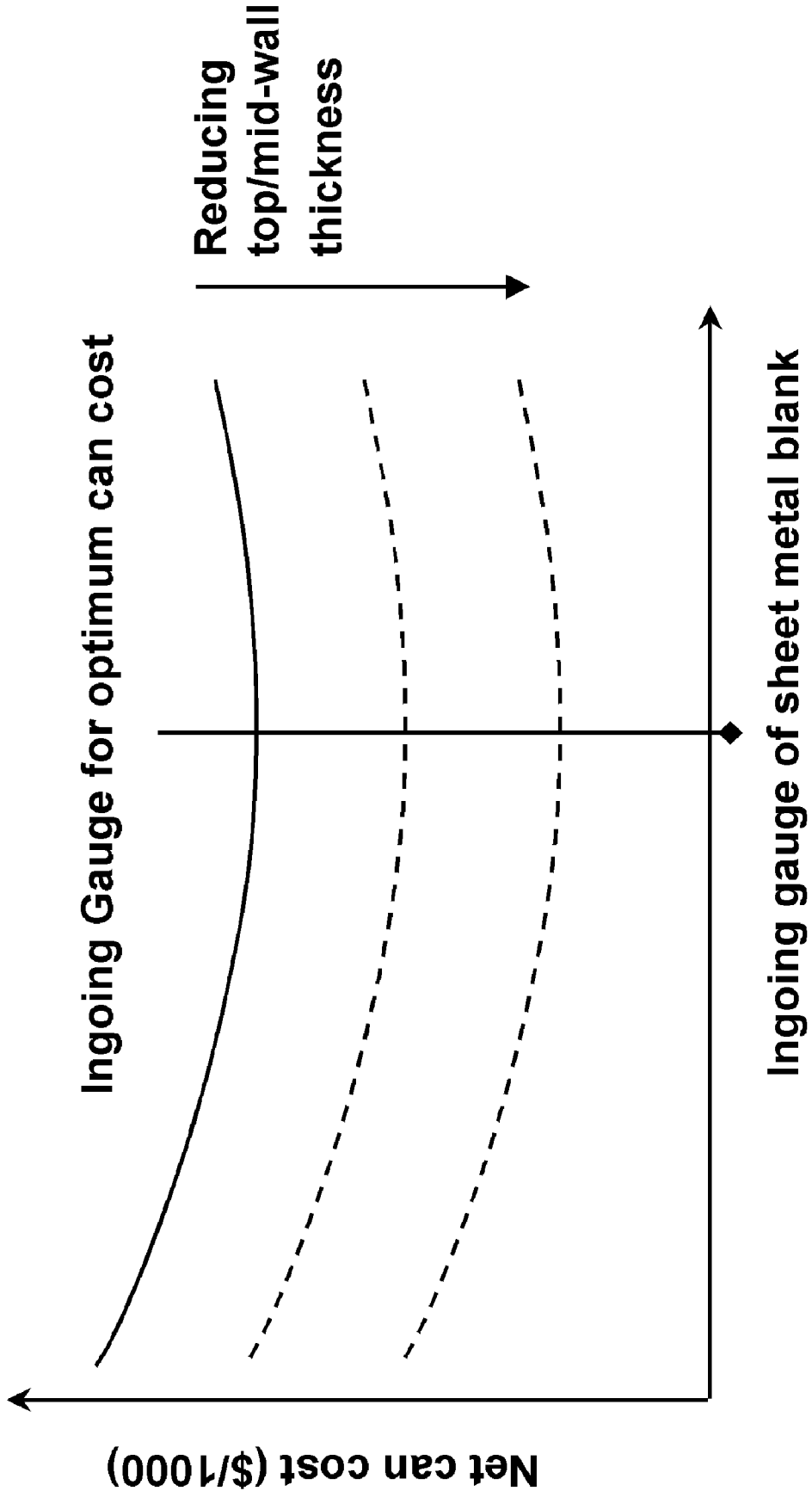

Figure 2

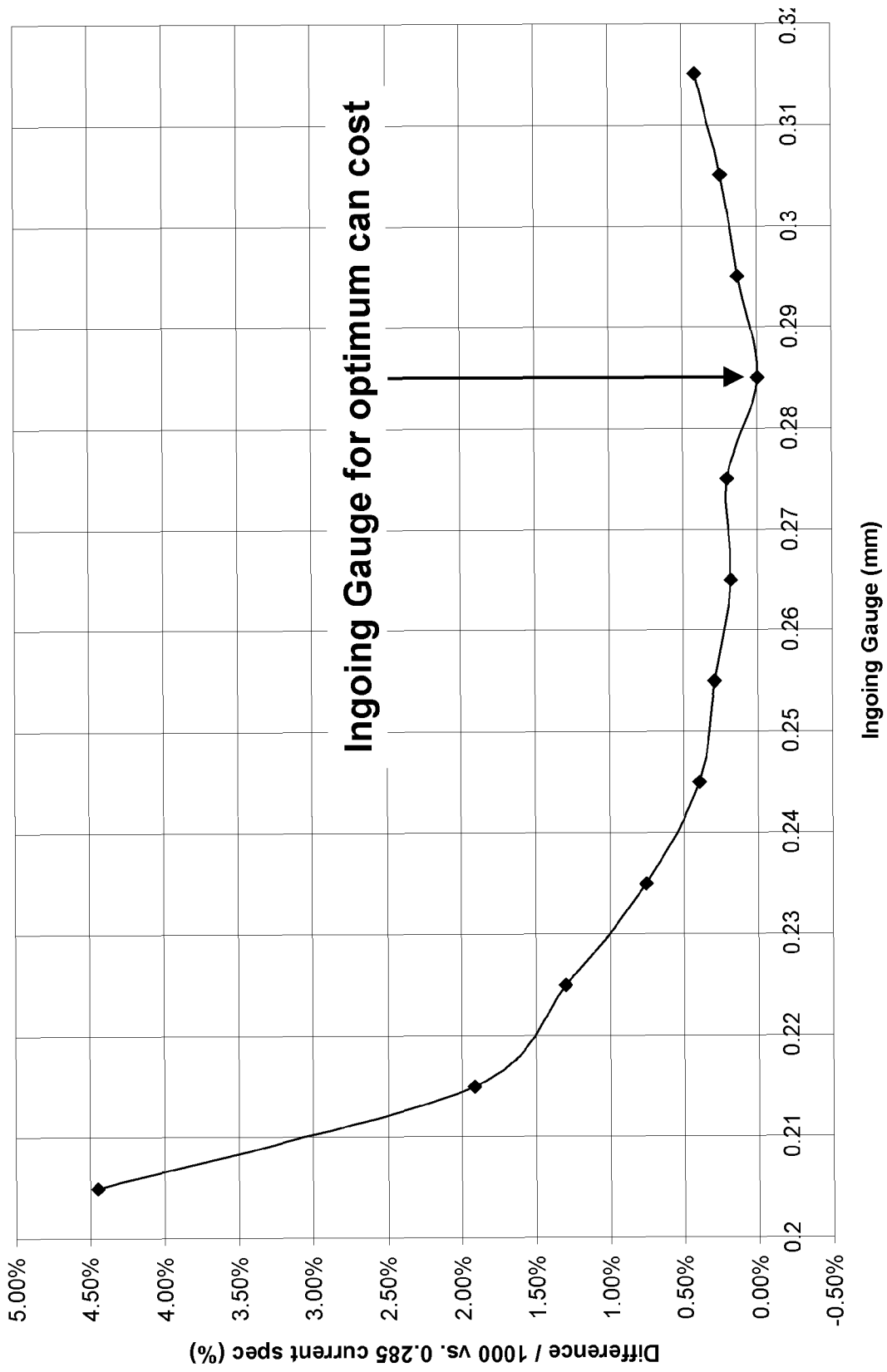
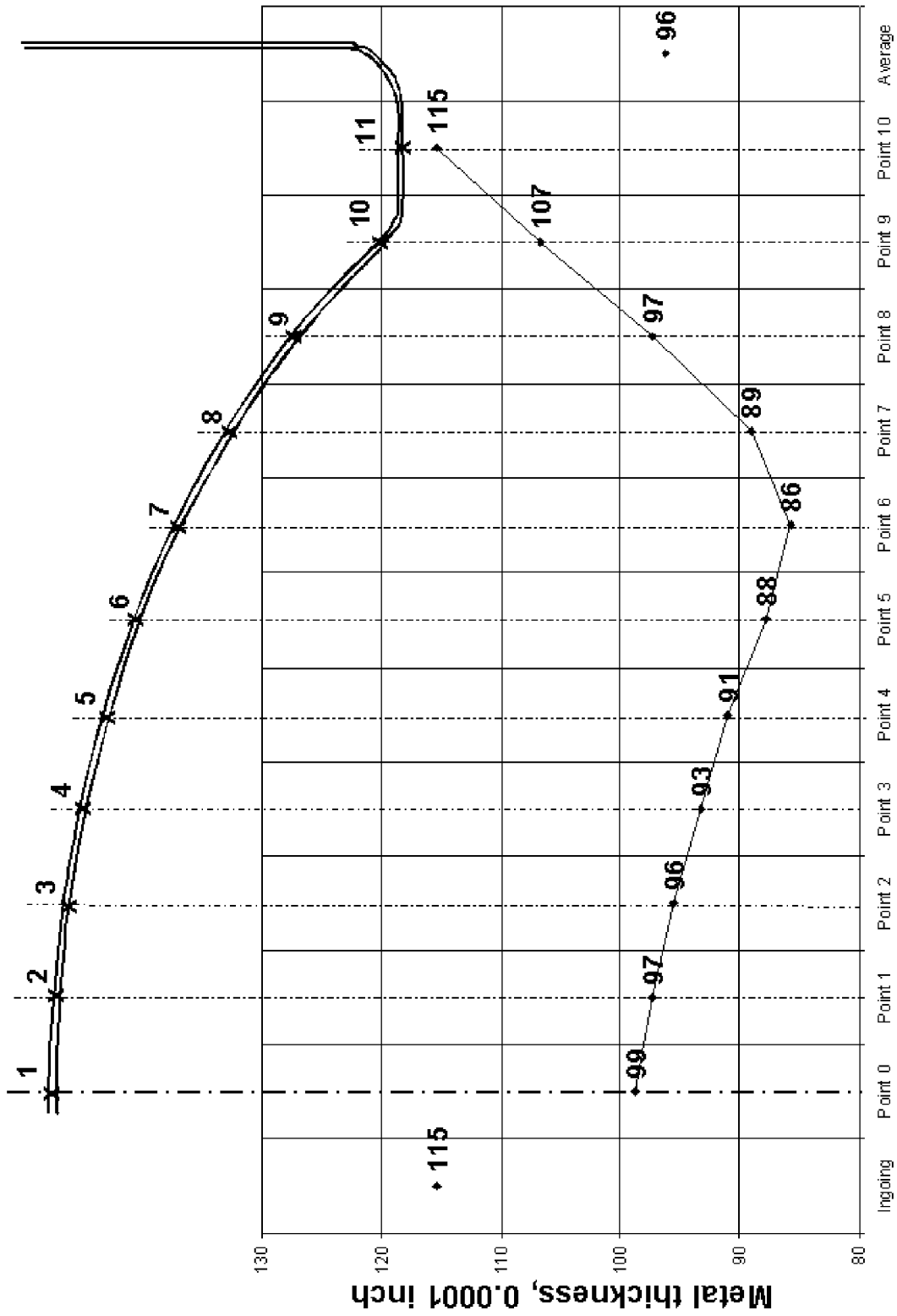

Figure 3



Measurement position on cup base

Figure 4

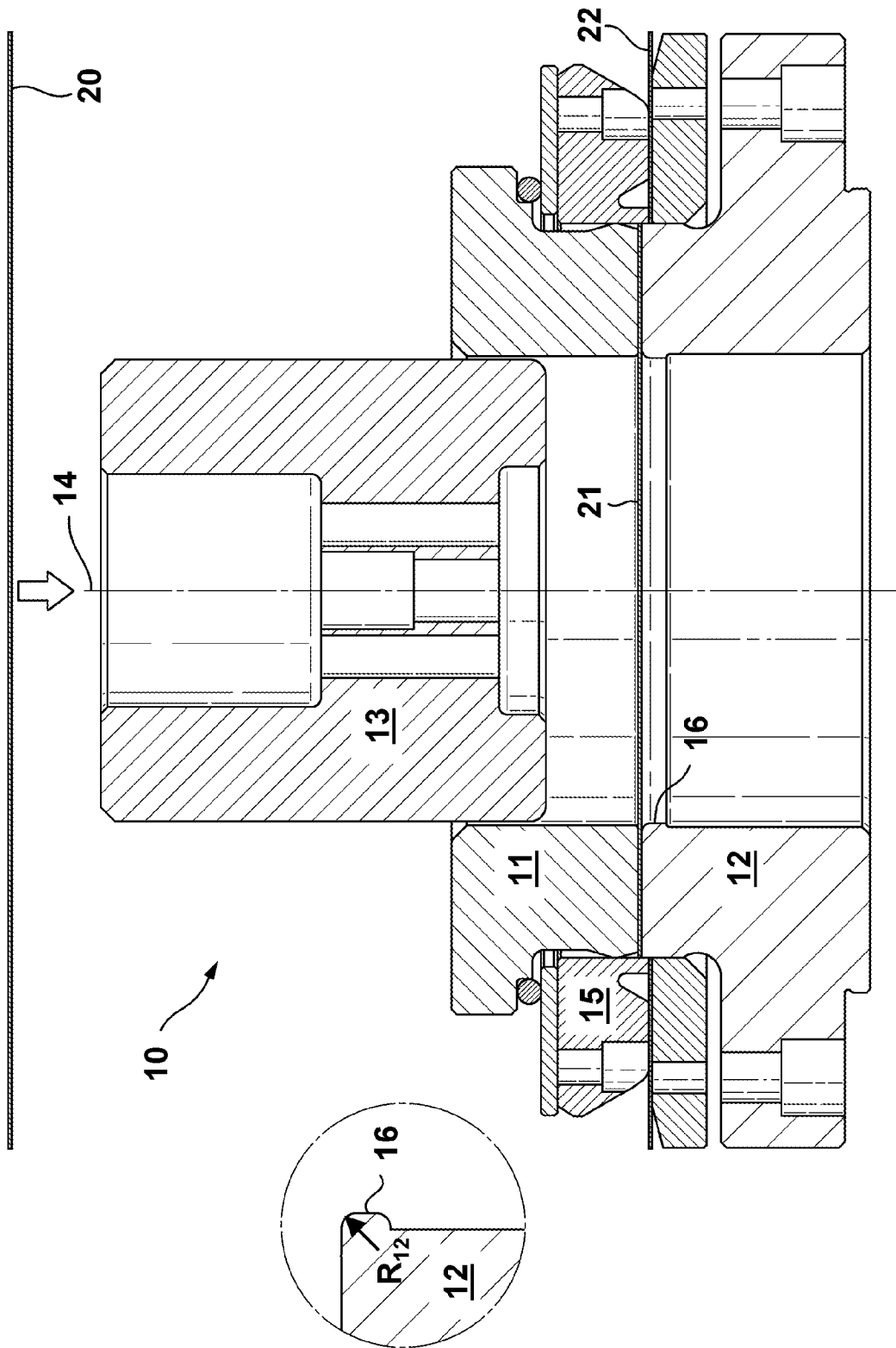

Figure 5a

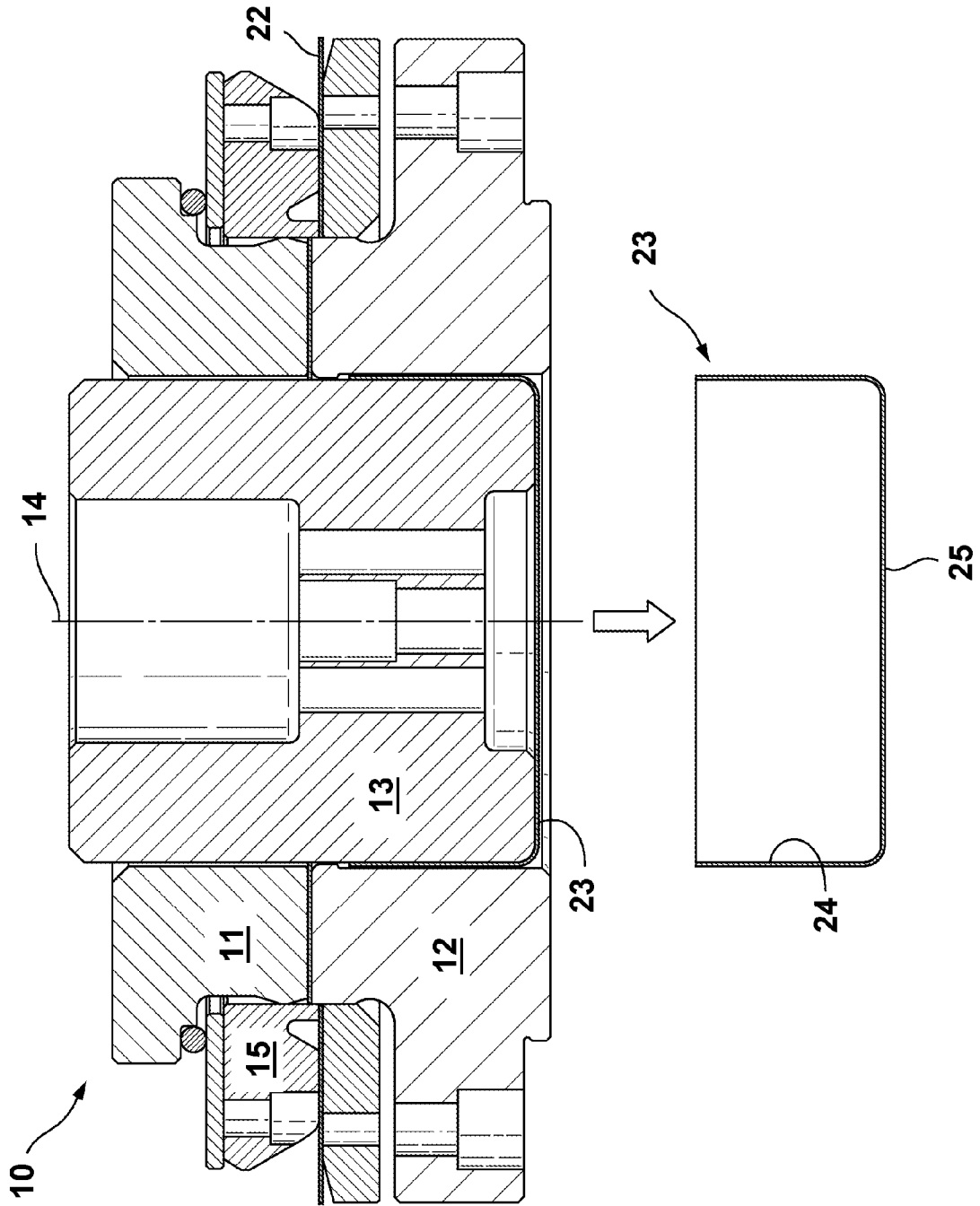

Figure 5b

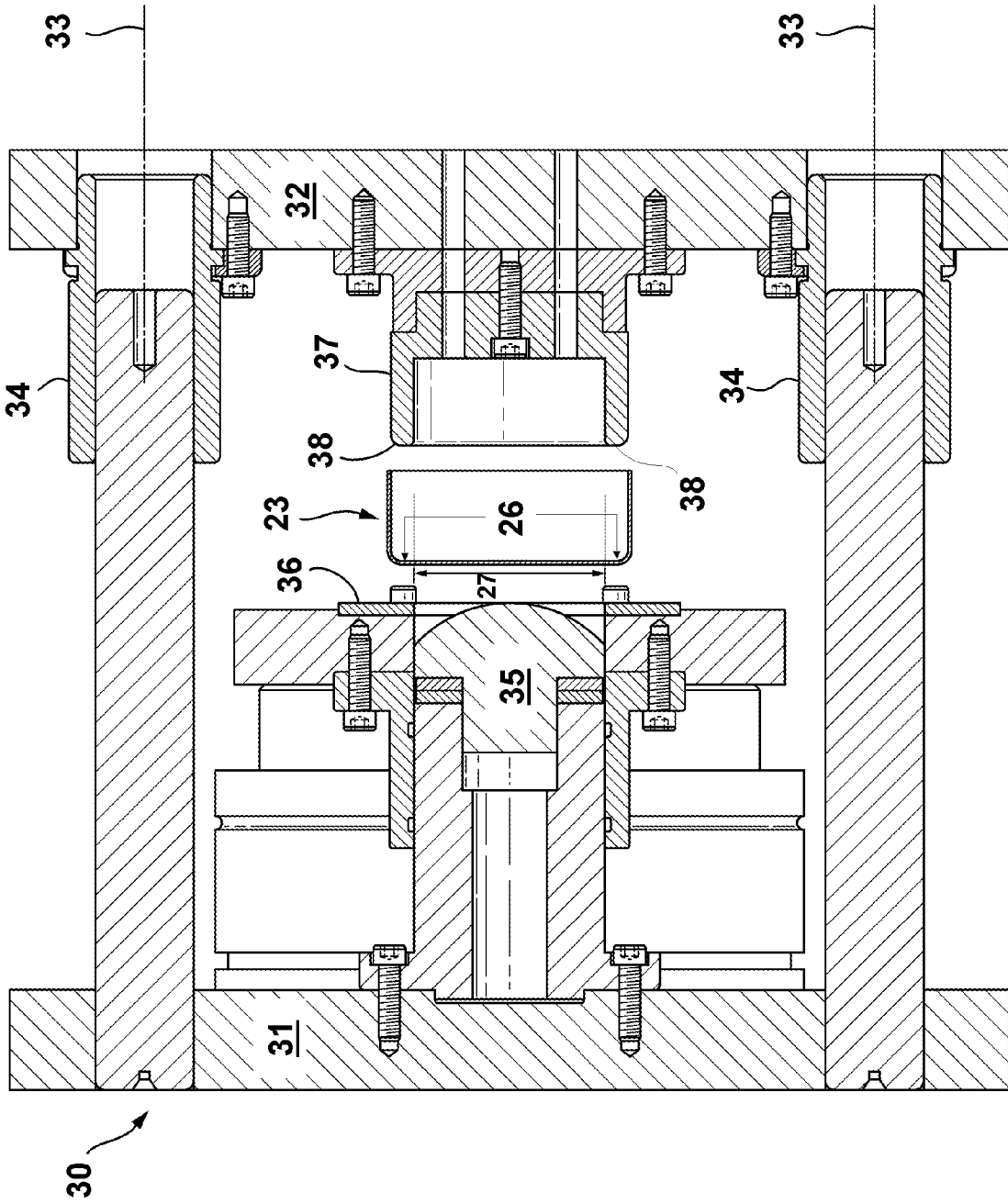

Figure 6a

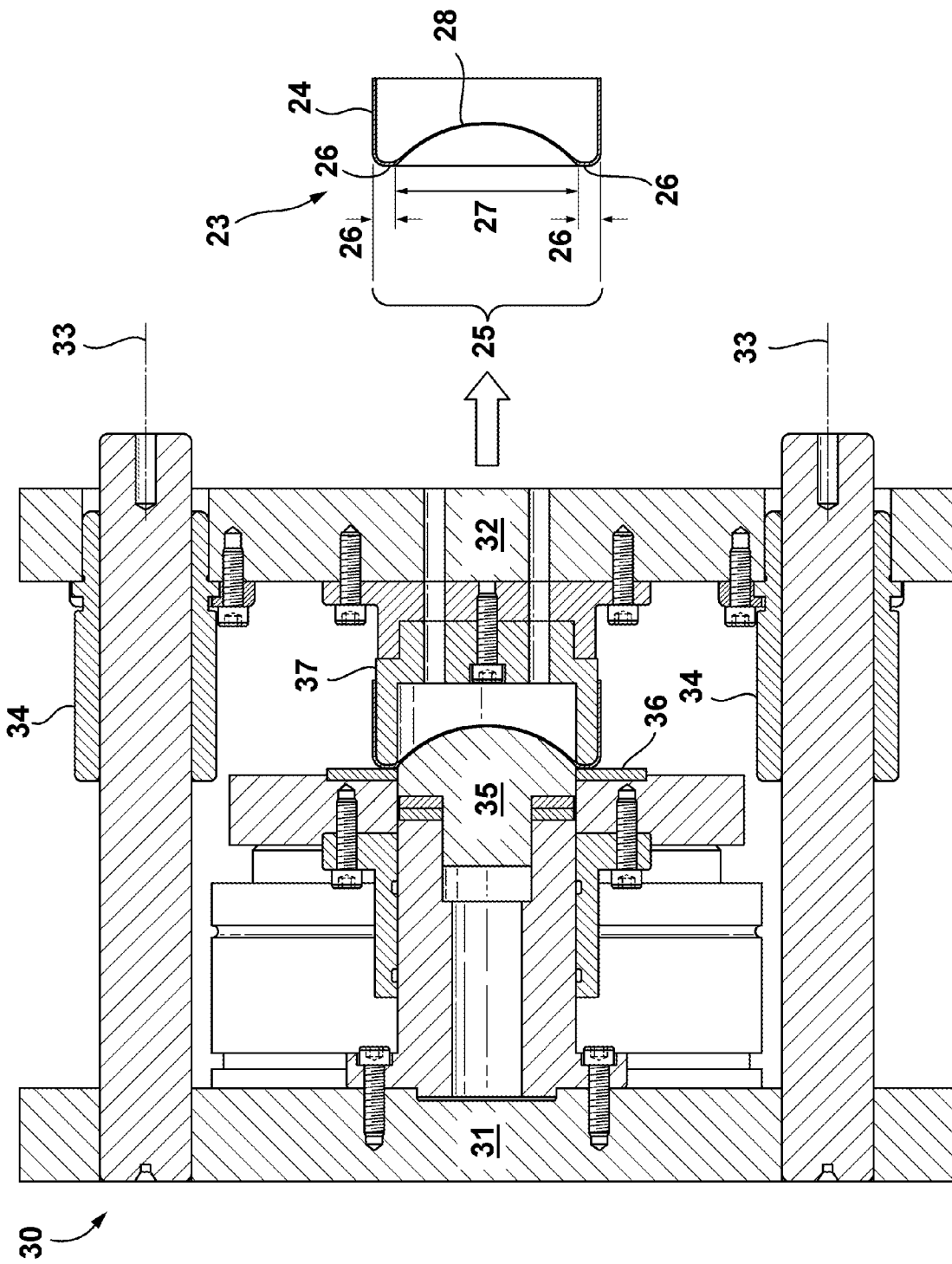

Figure 6b

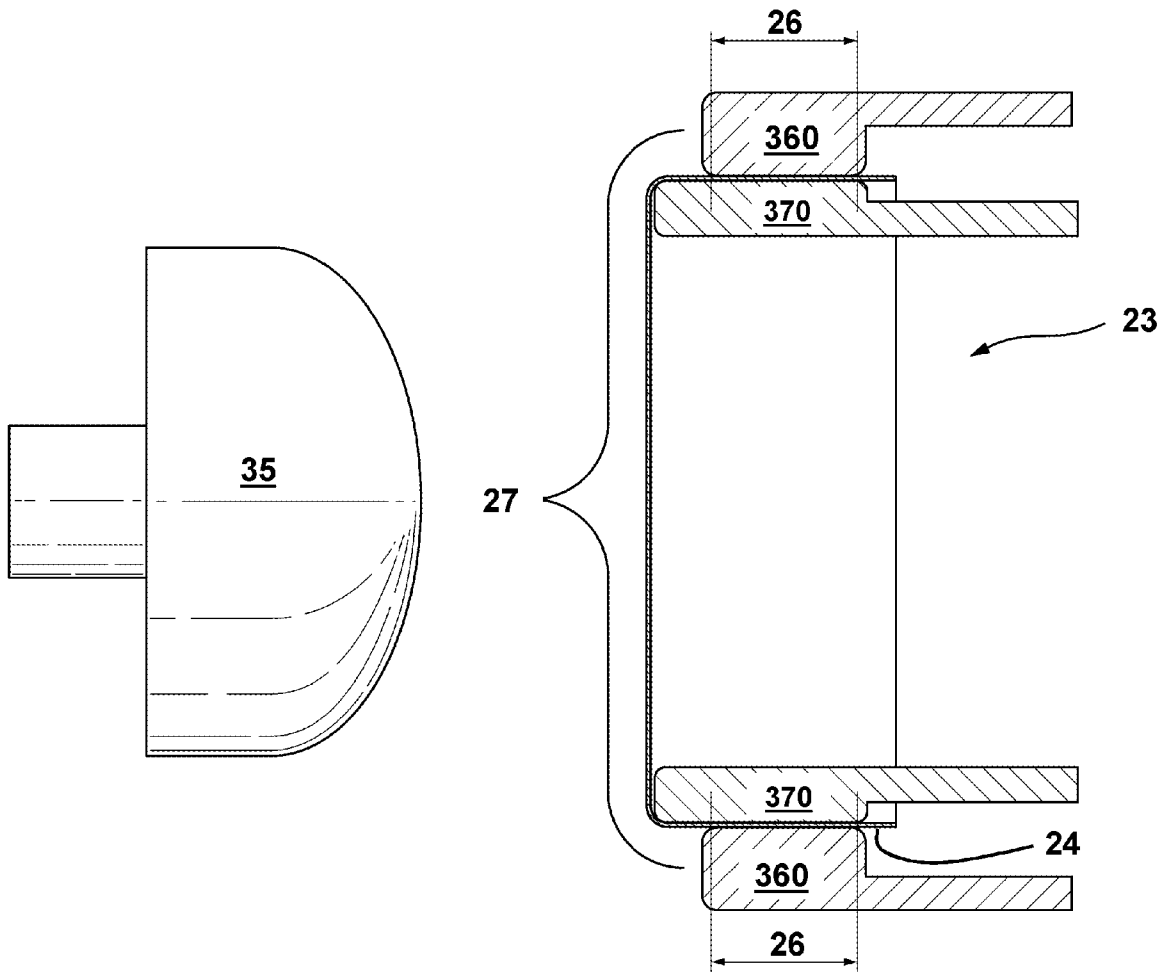

Figure 7

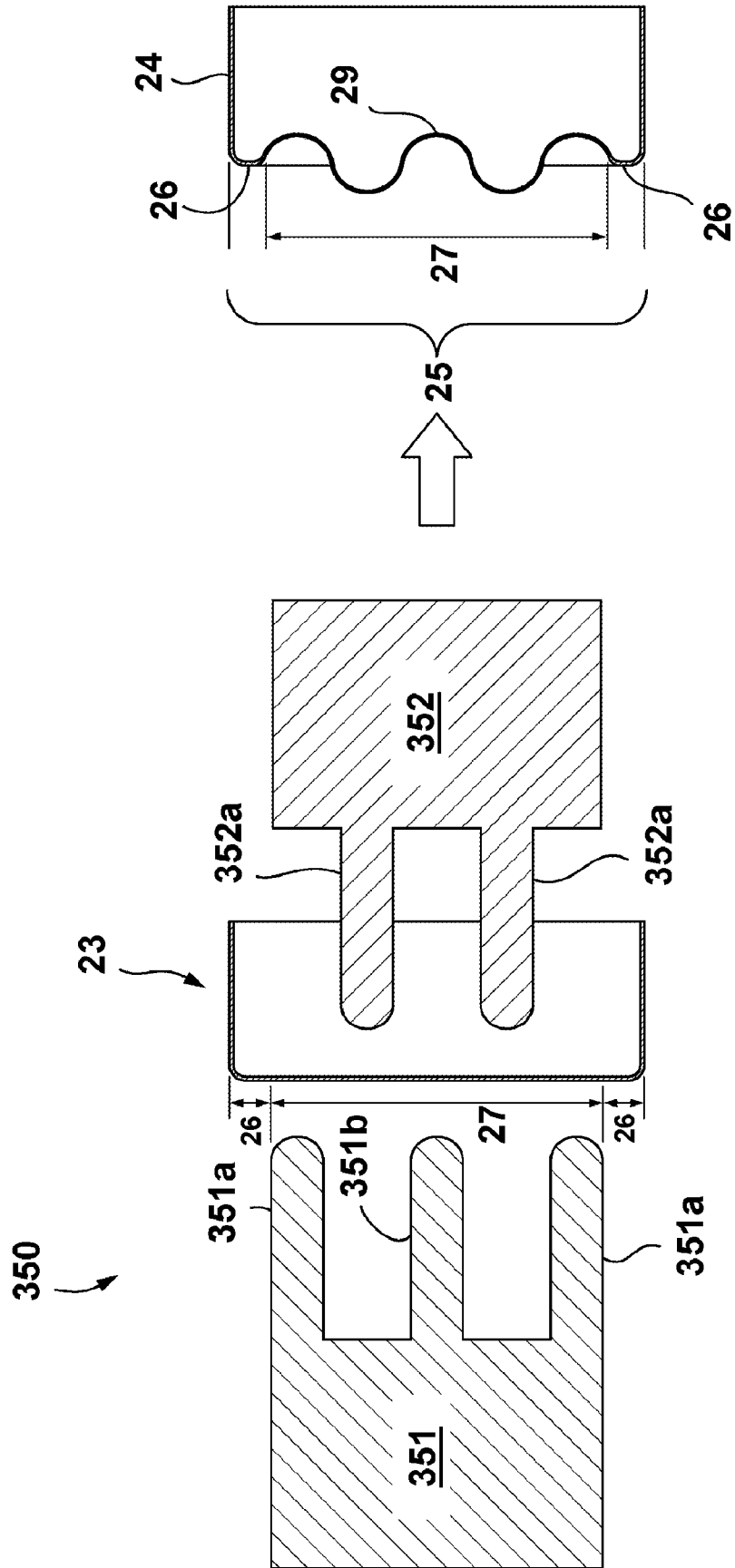

Figure 8

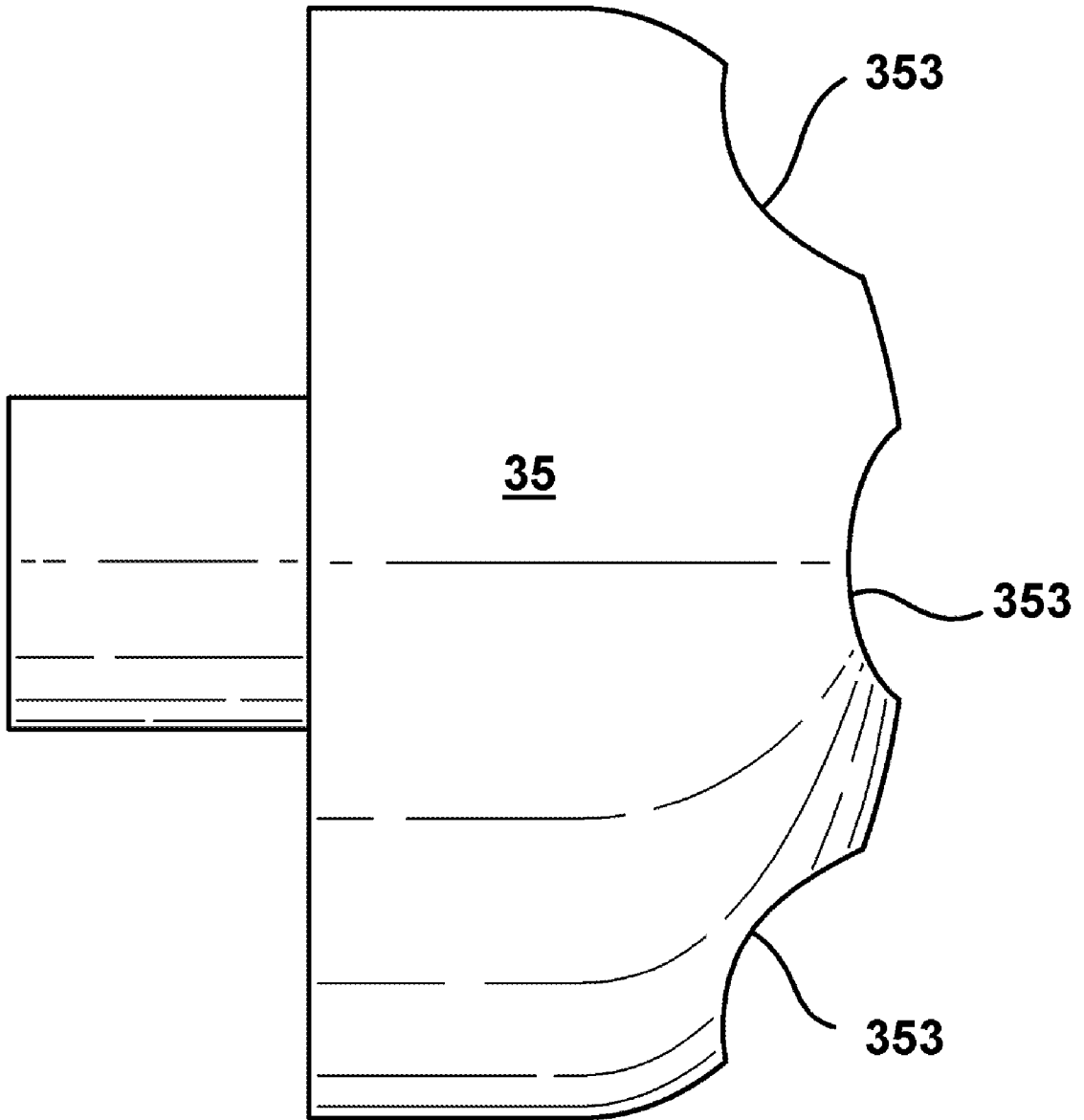

Figure 9

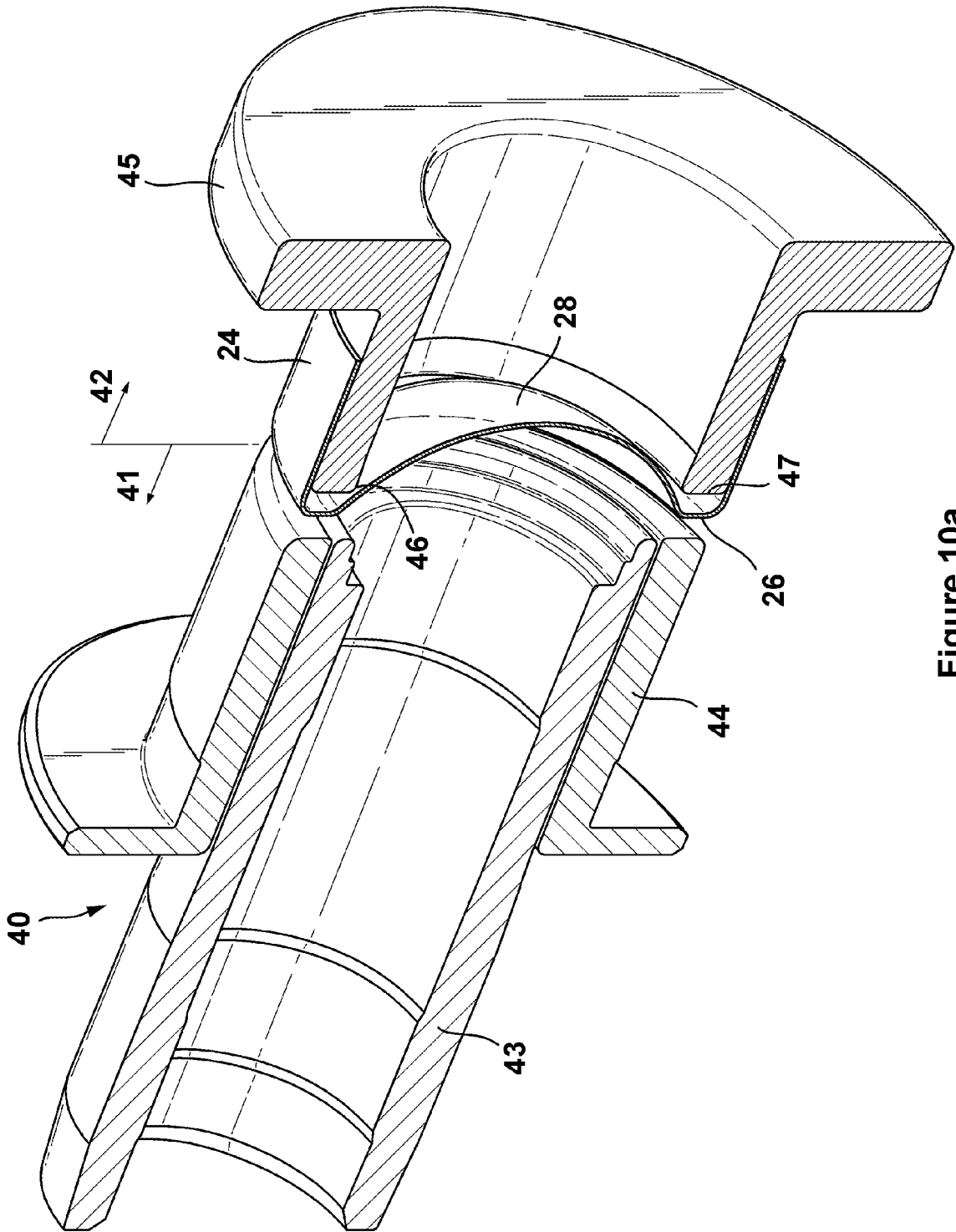

Figure 10a

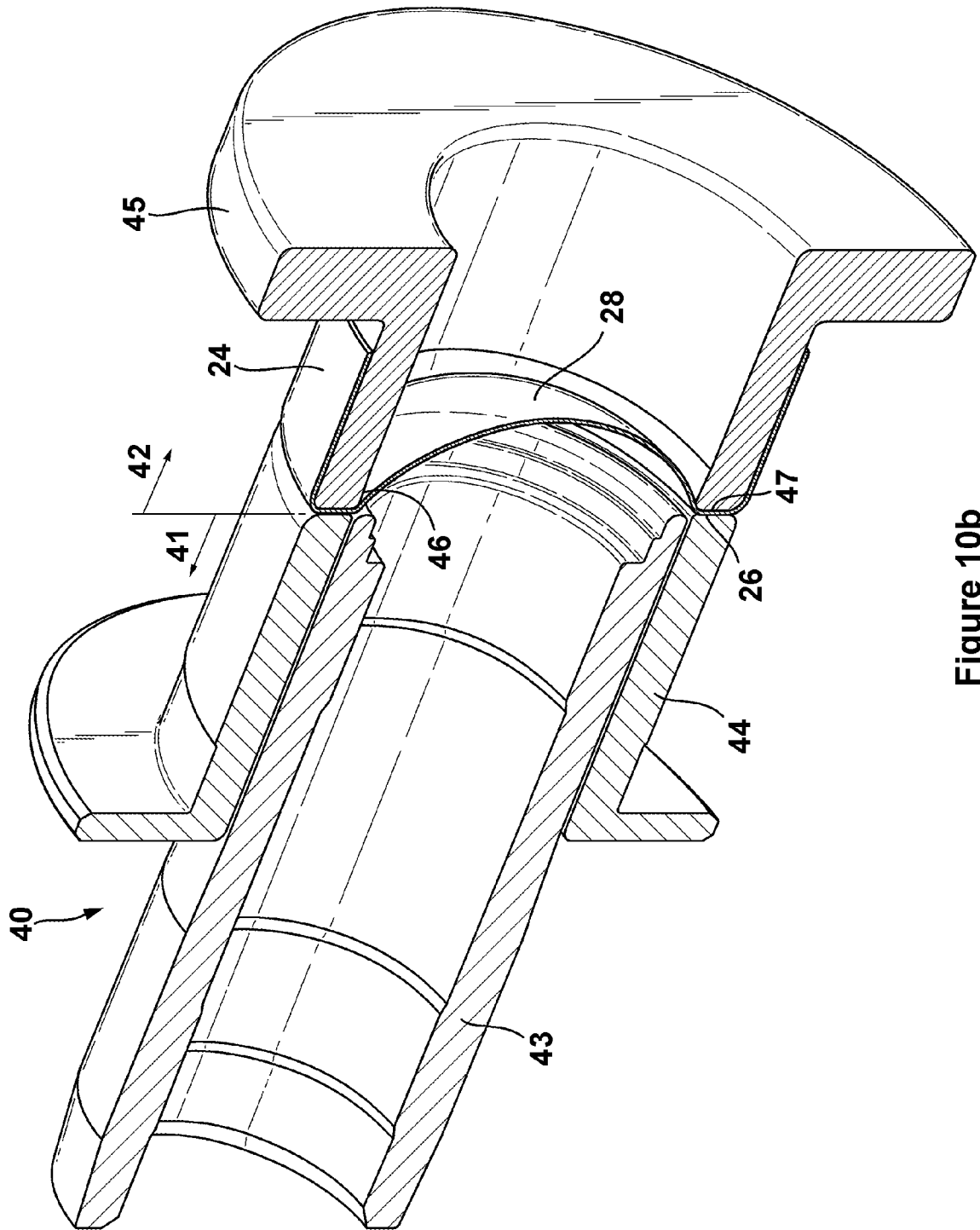

Figure 10b

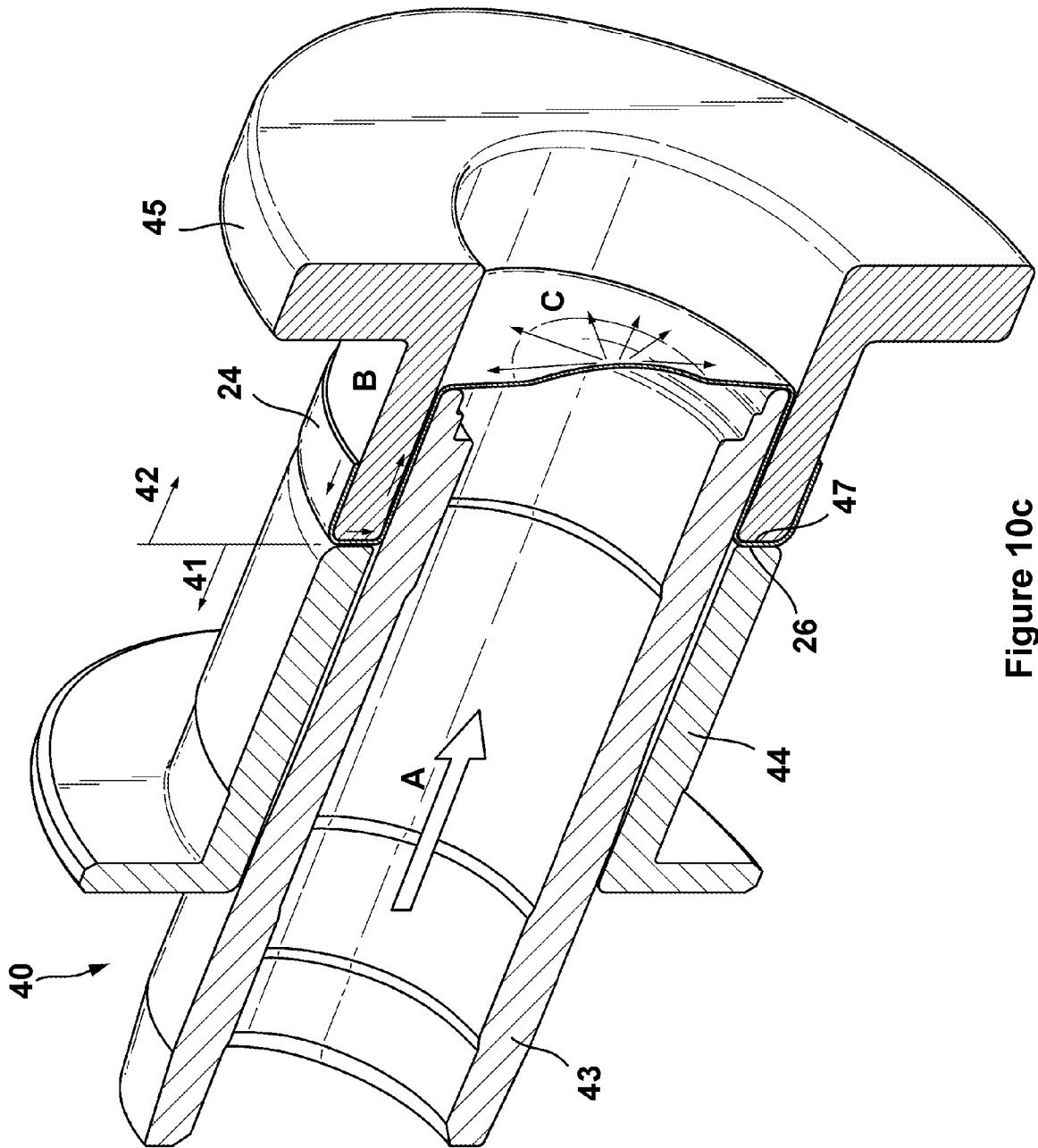

Figure 10c

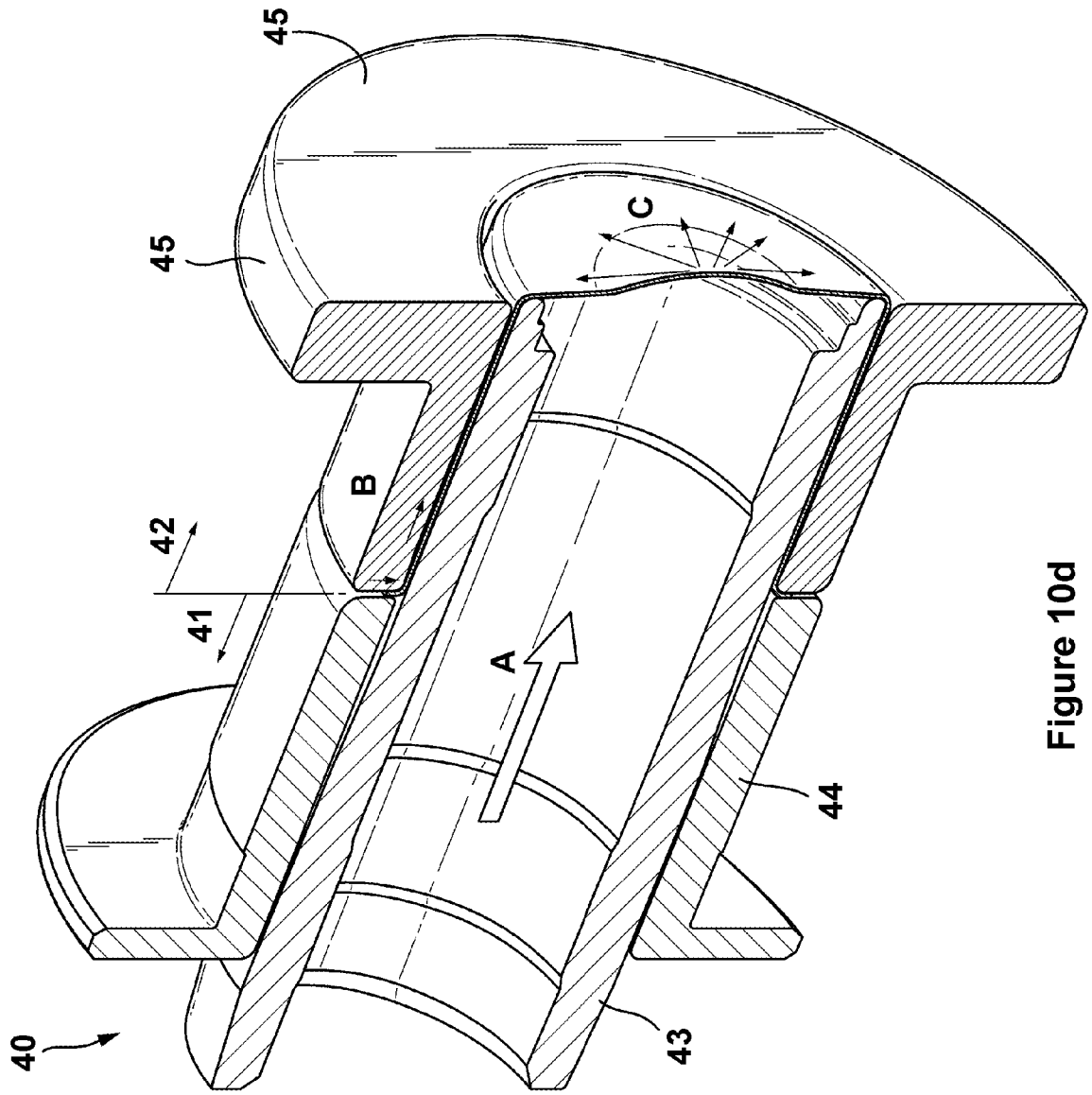

Figure 10d

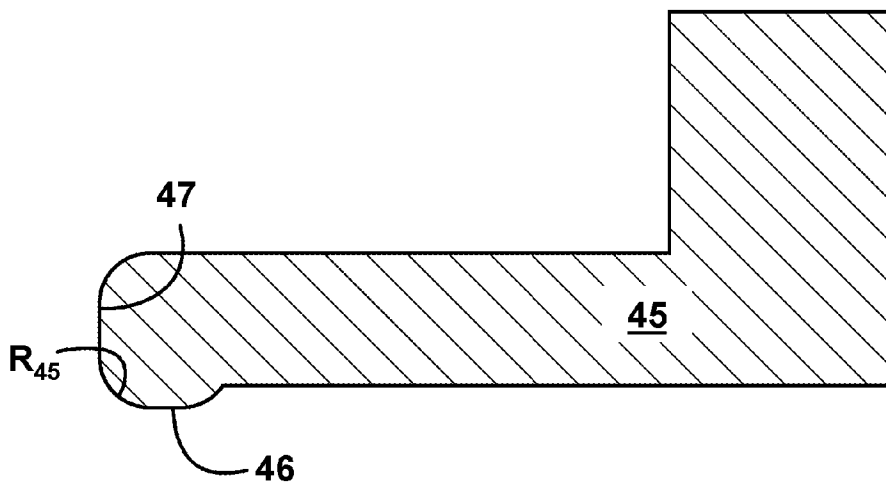

Figure 11

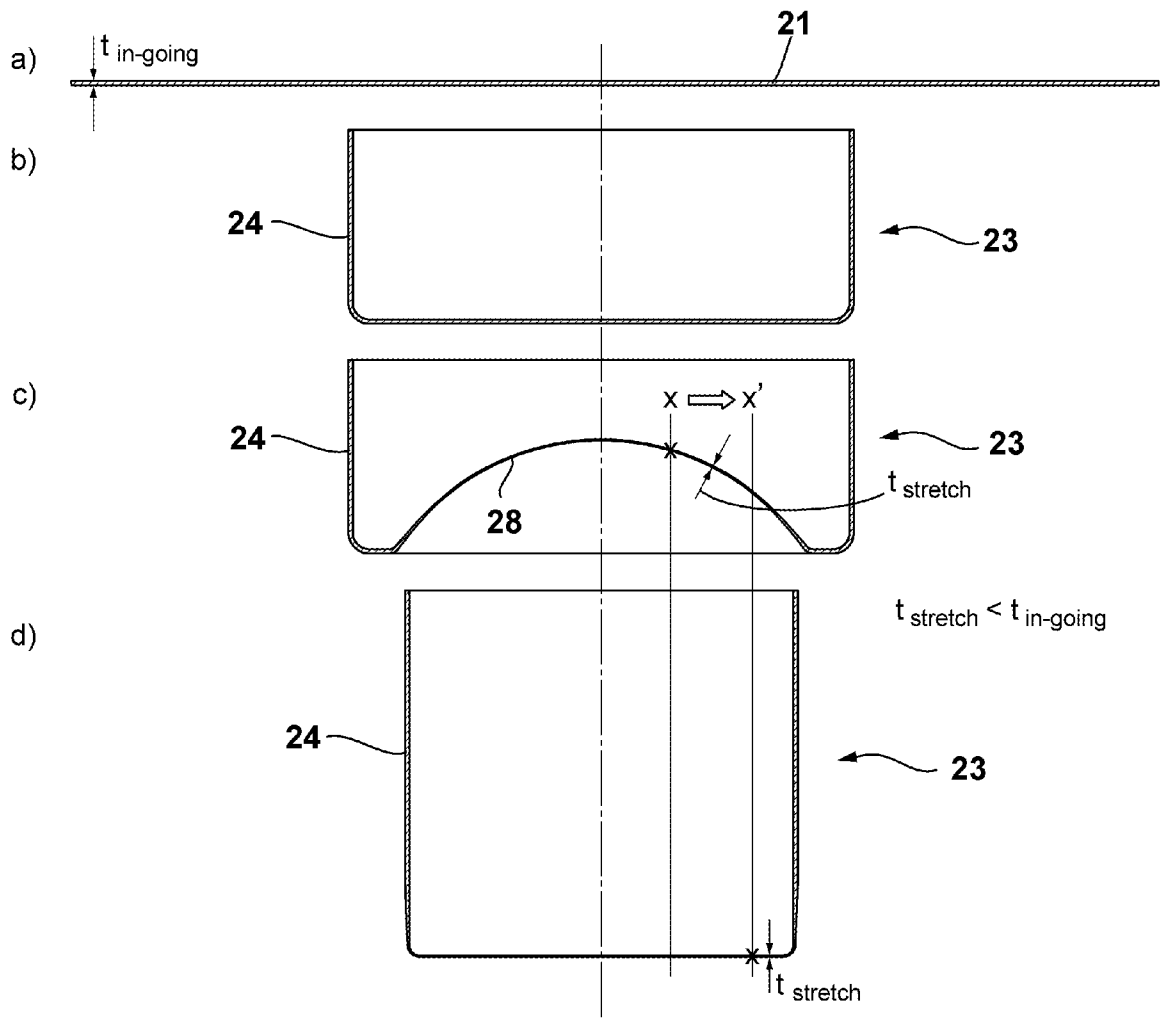

Figure 12

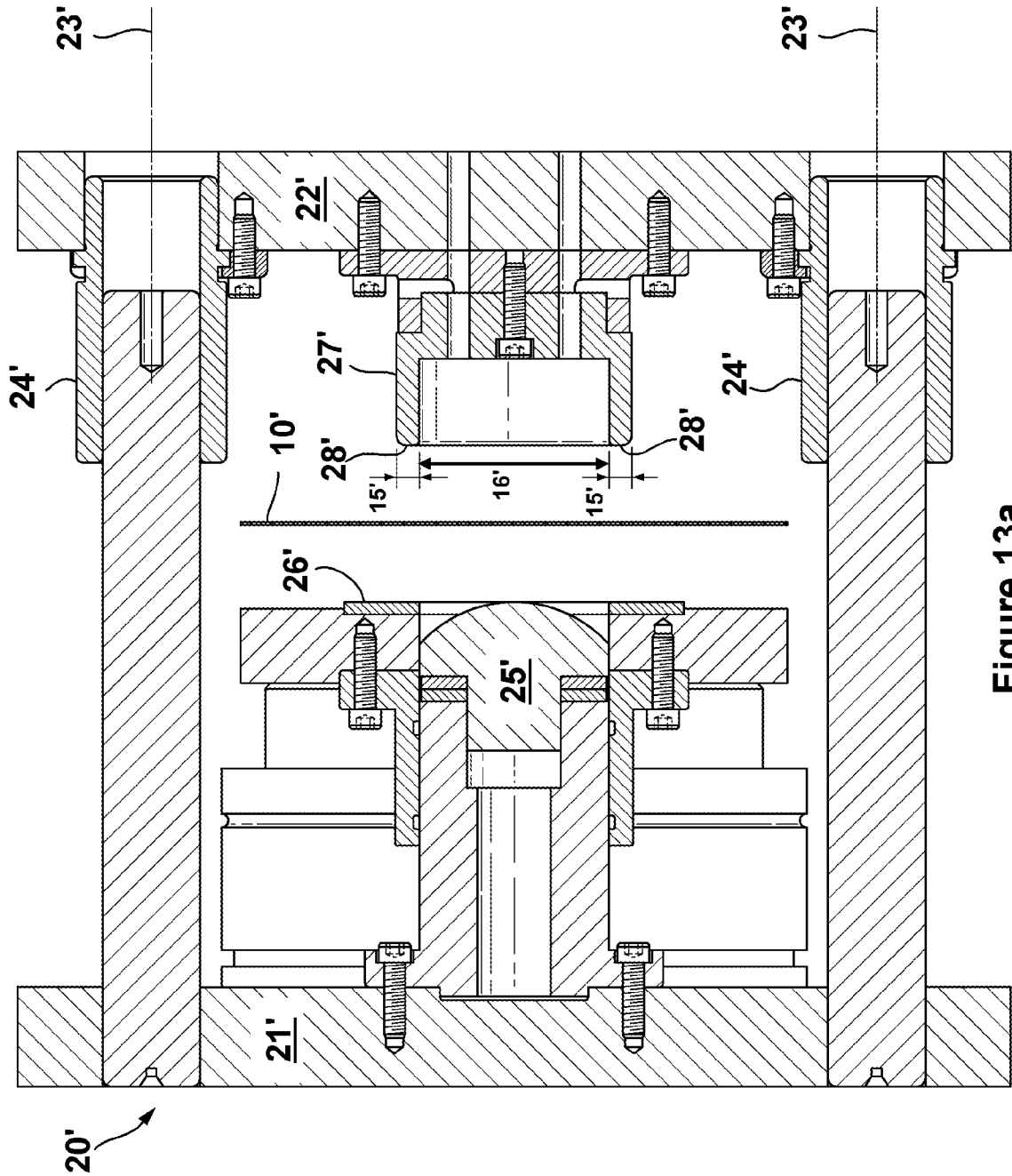

Figure 13a

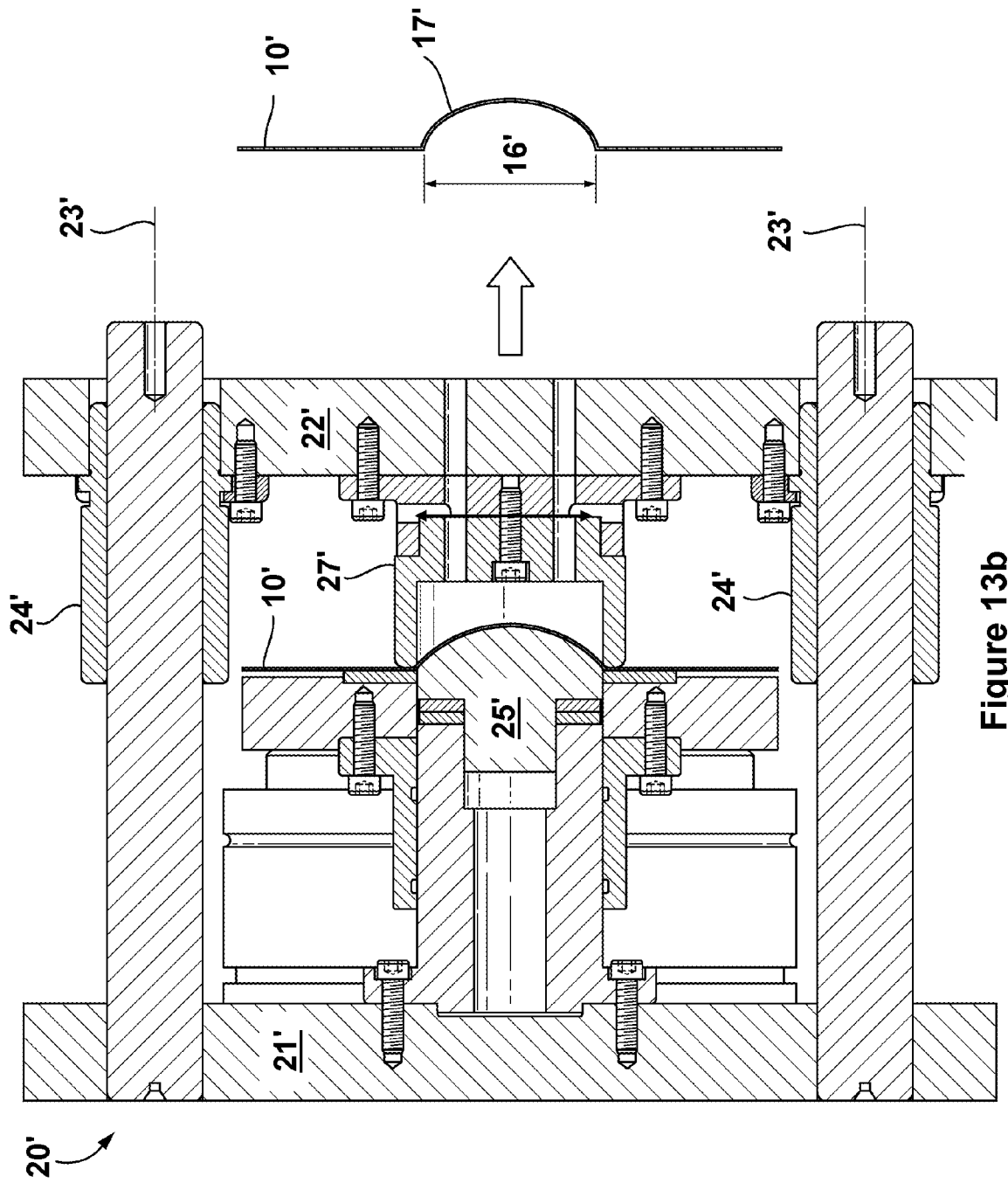

Figure 13b

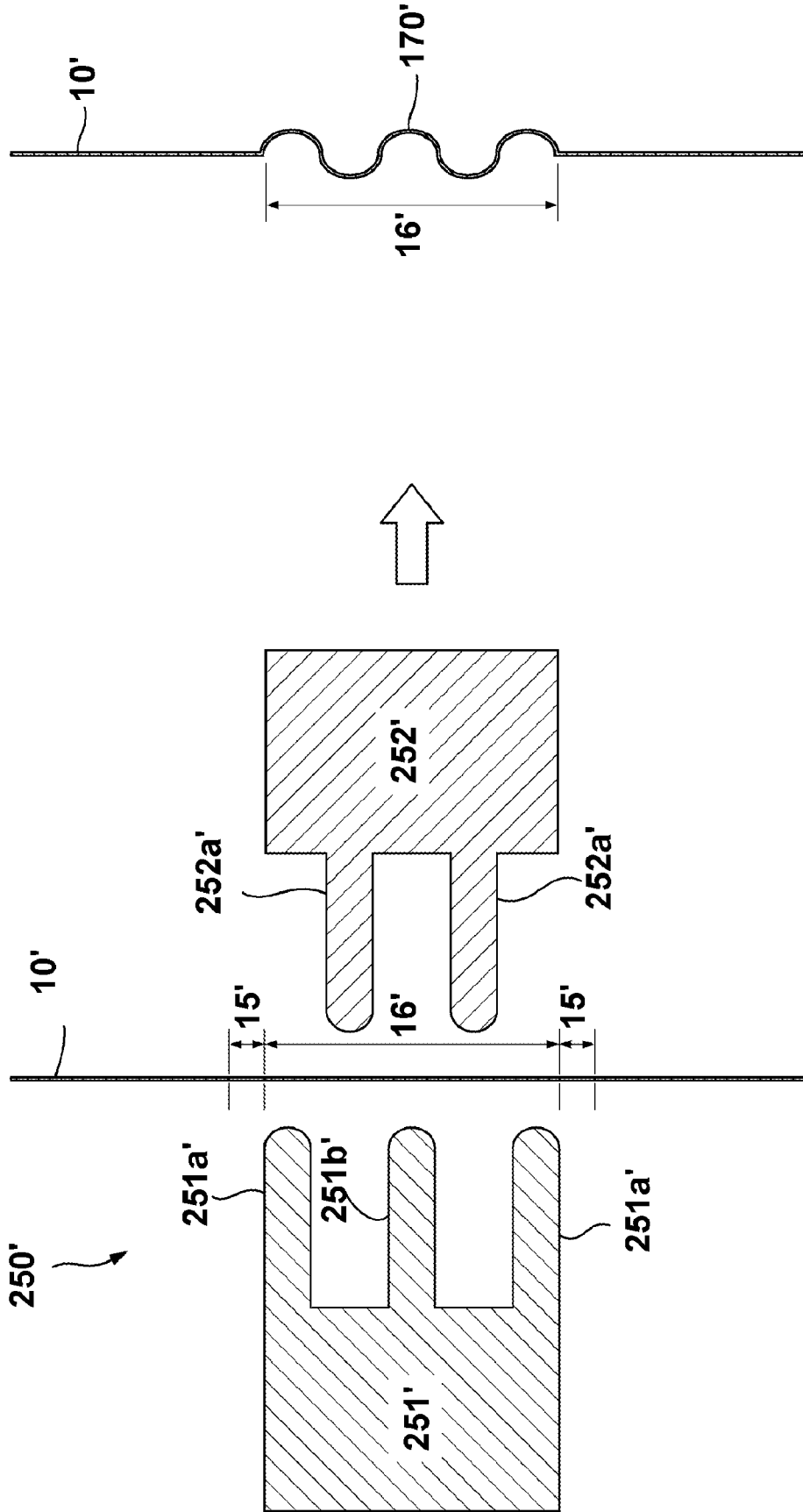

Figure 14

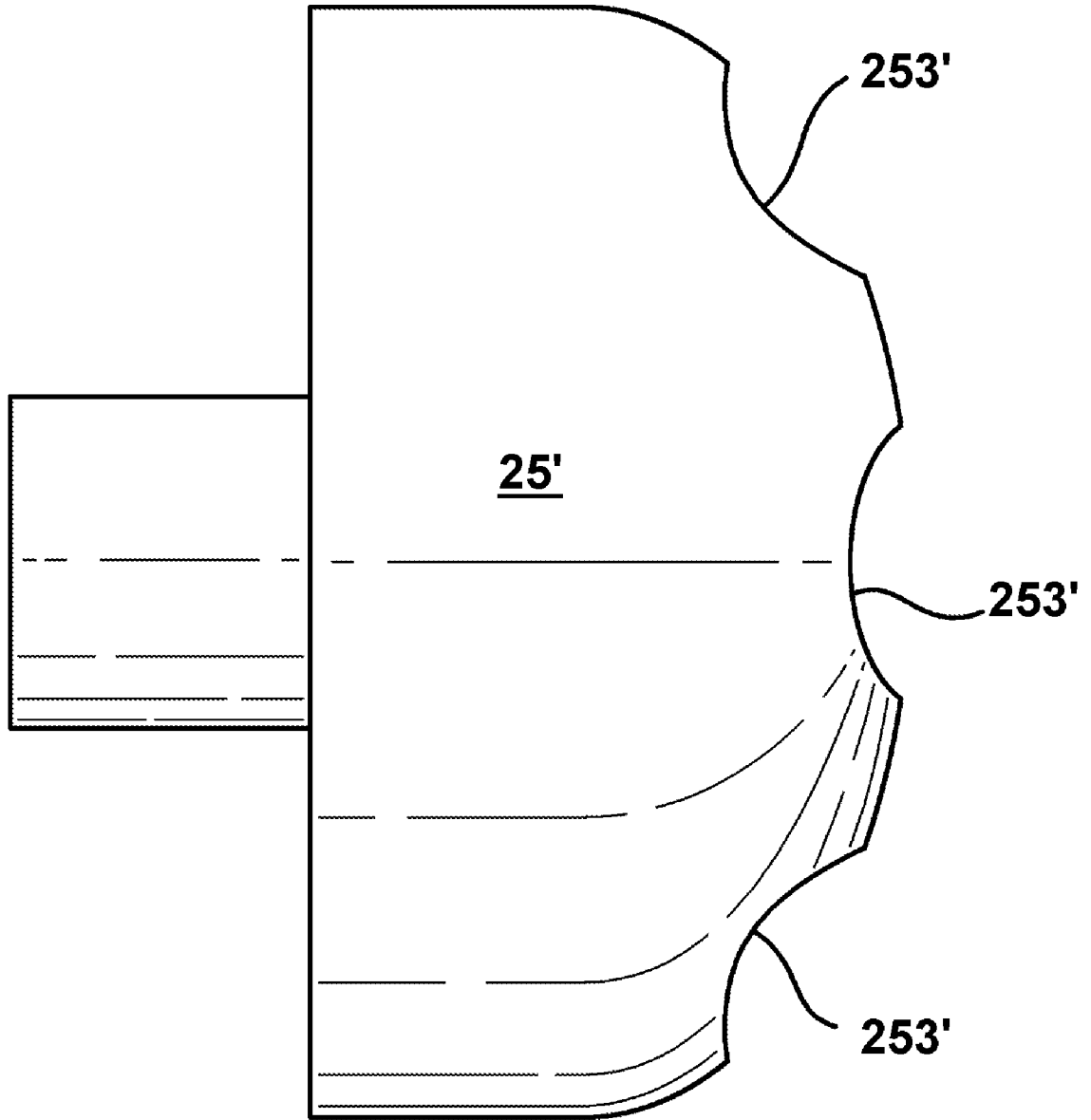

Figure 15

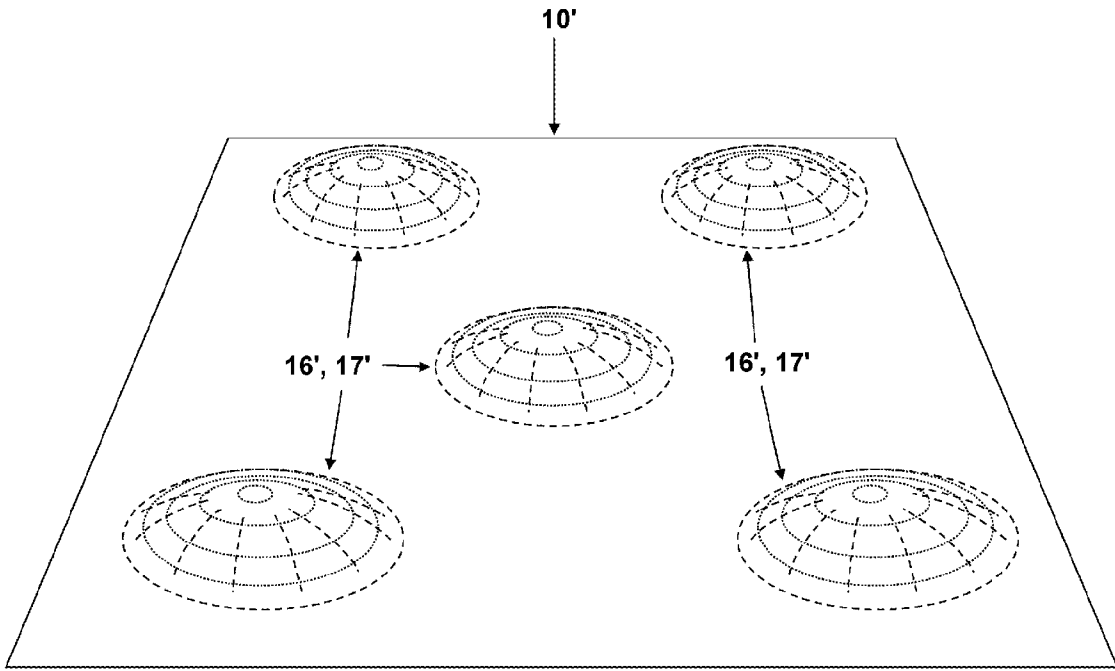

Figure 16

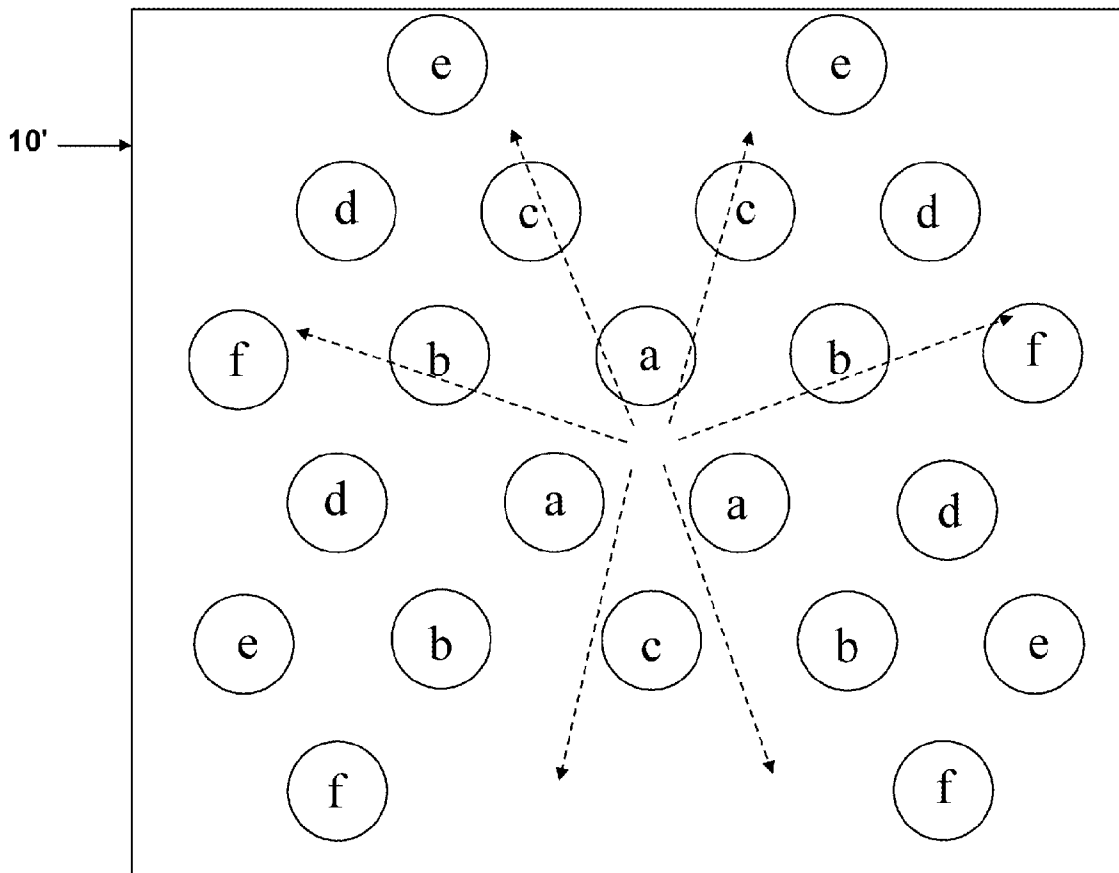

Figure 17a

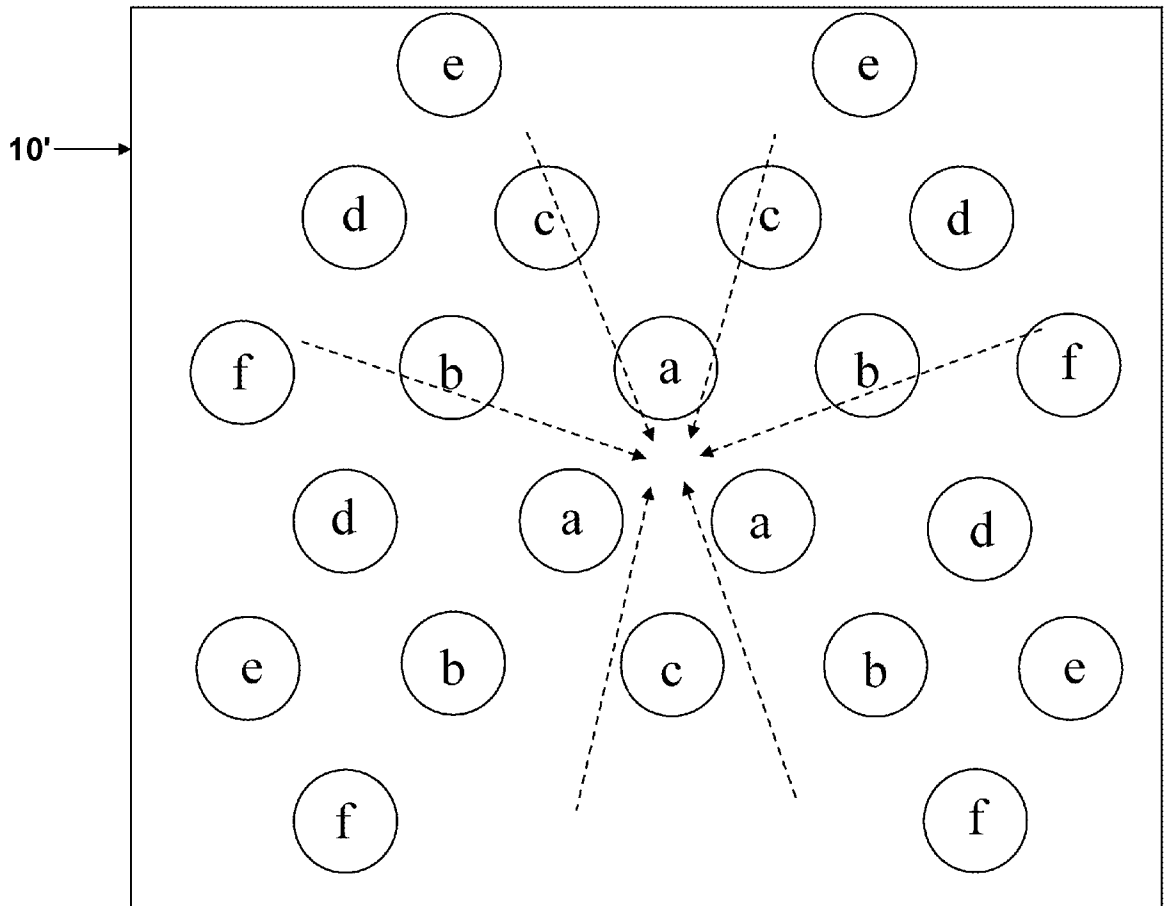

Figure 17b

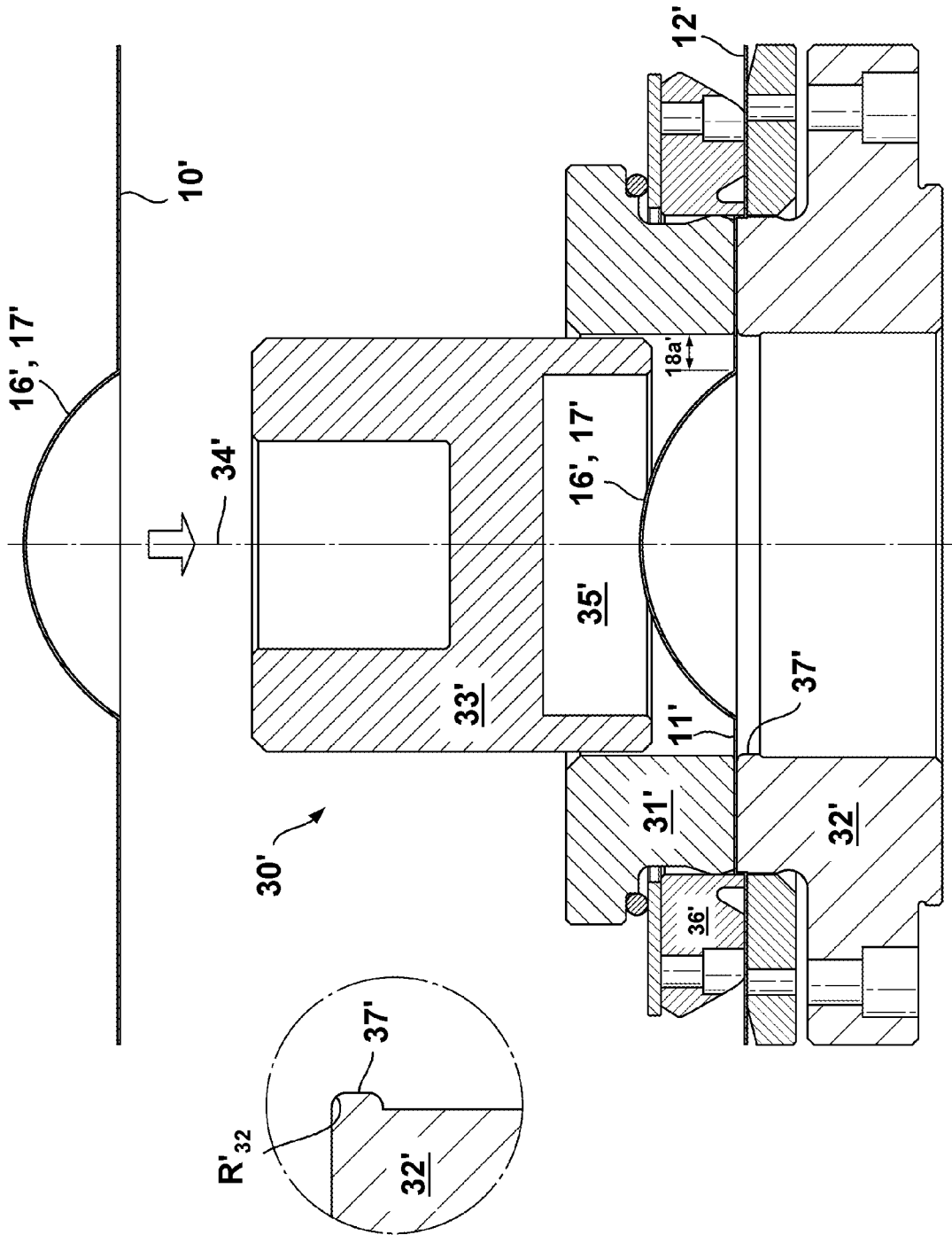

Figure 18a

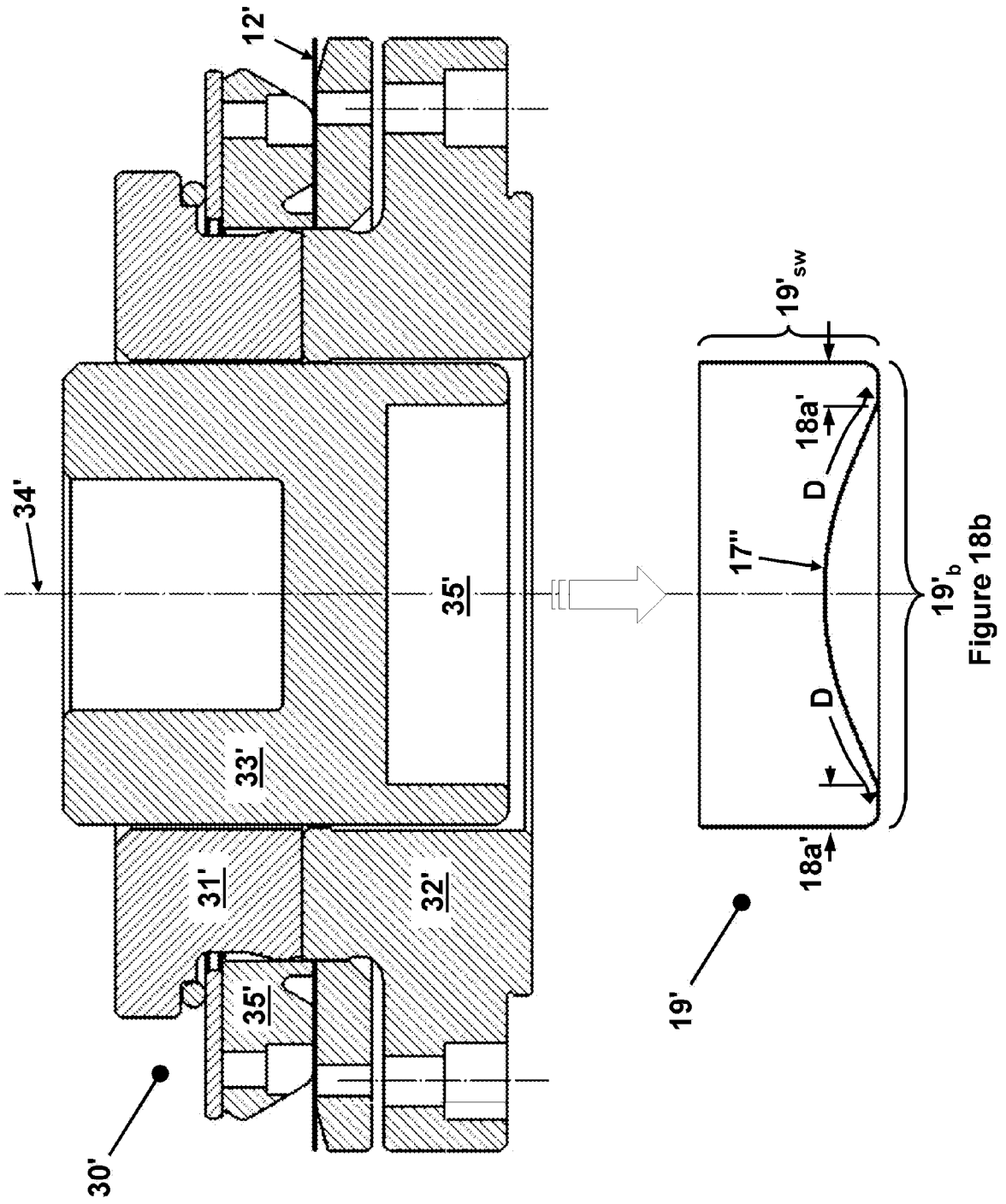

Figure 18b

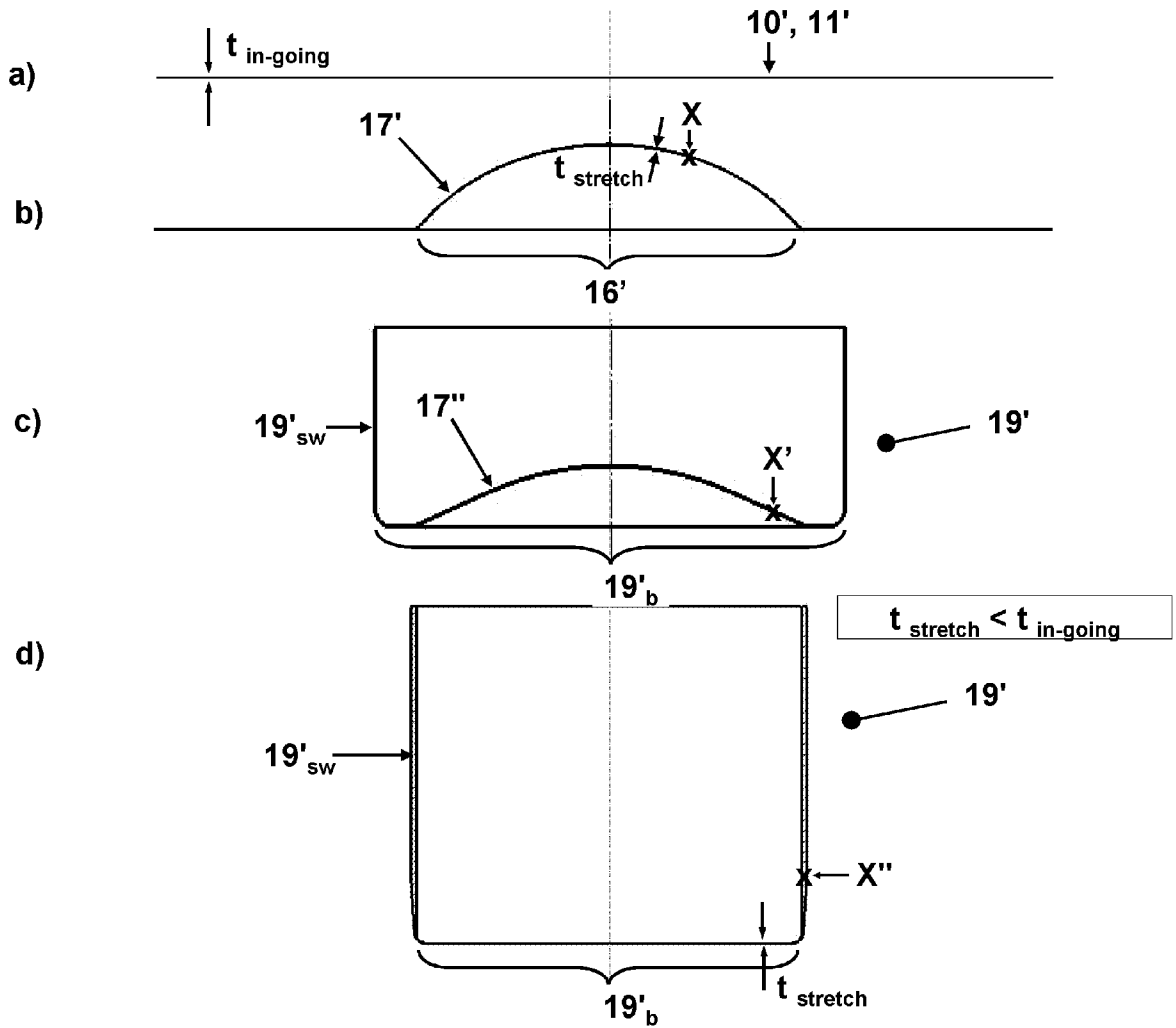

Figure 19

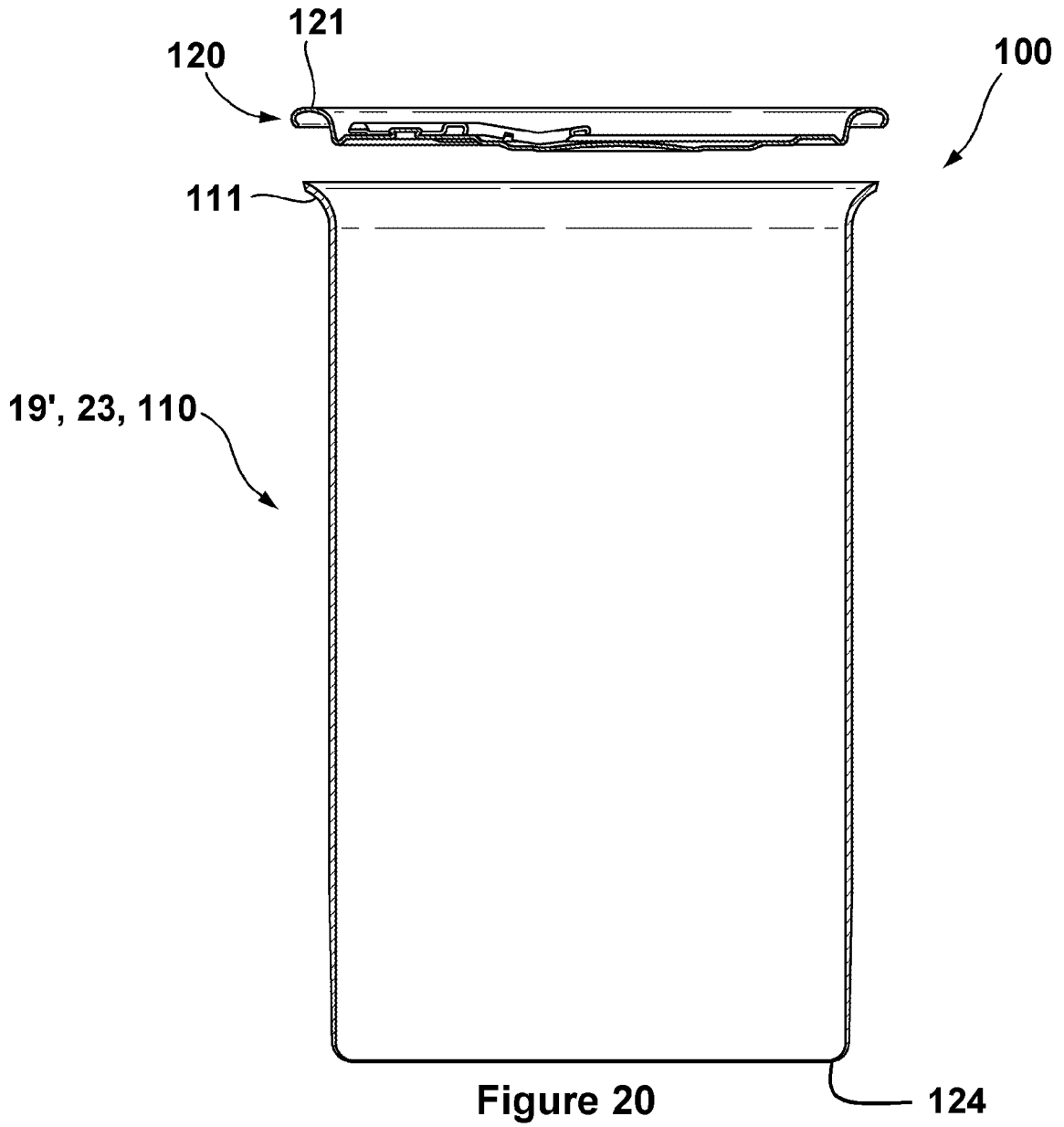

Figure 20

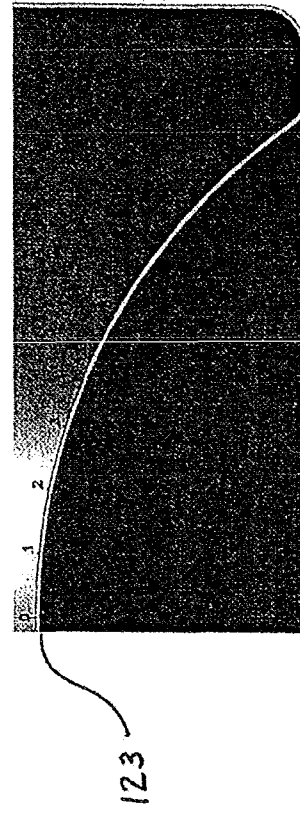
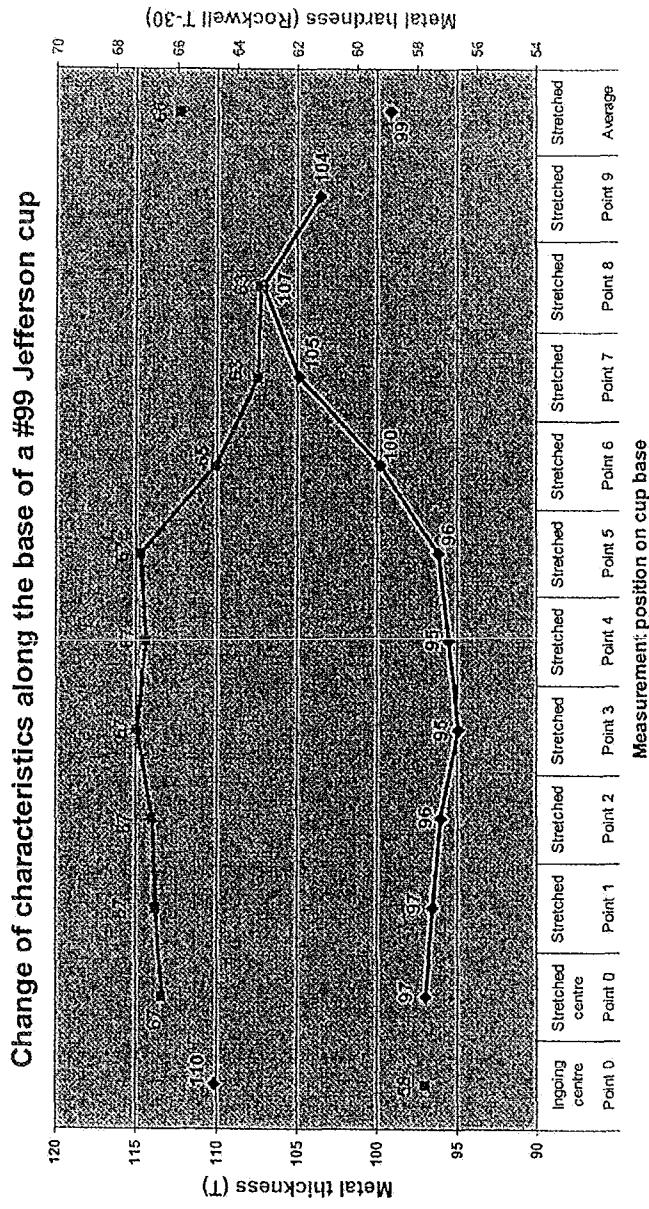

Figure 21

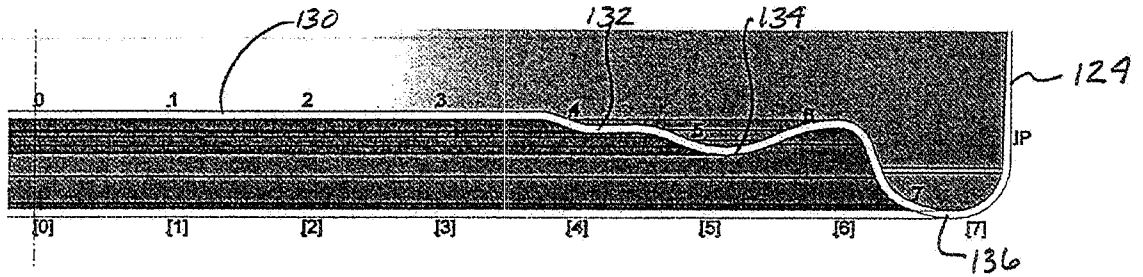

Figure 22

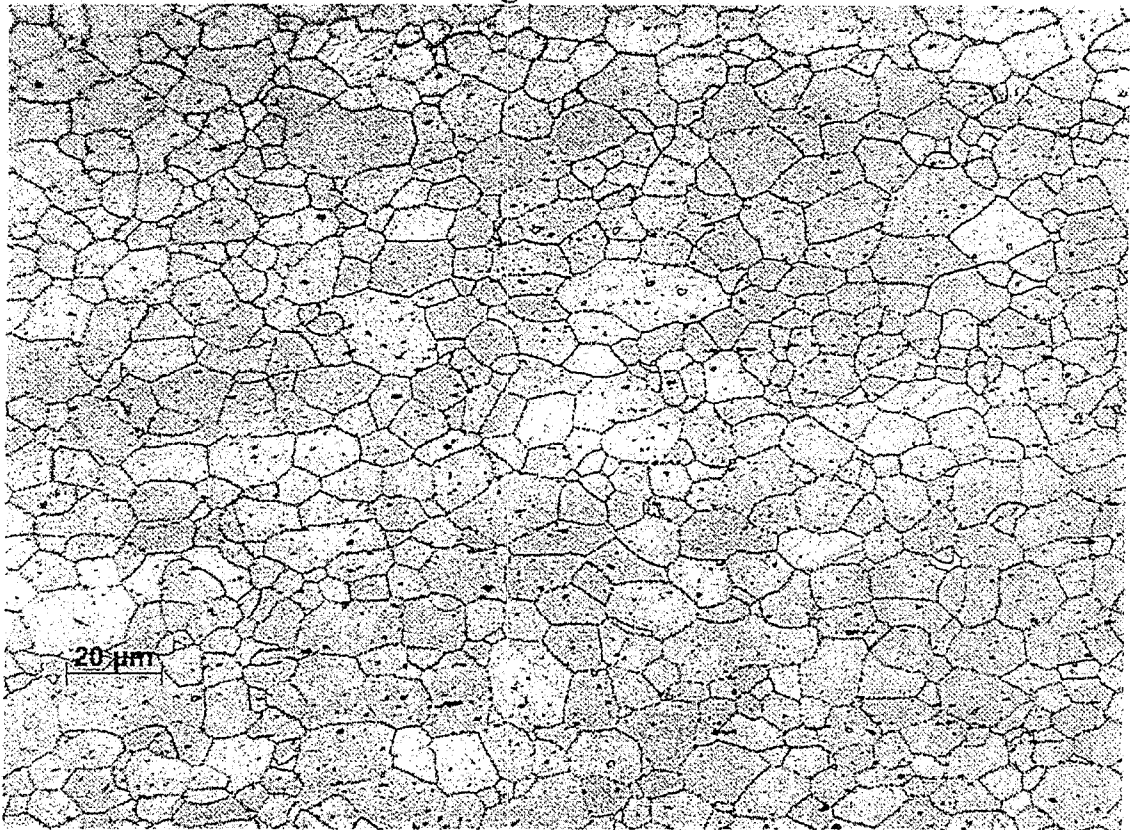

Figure 23

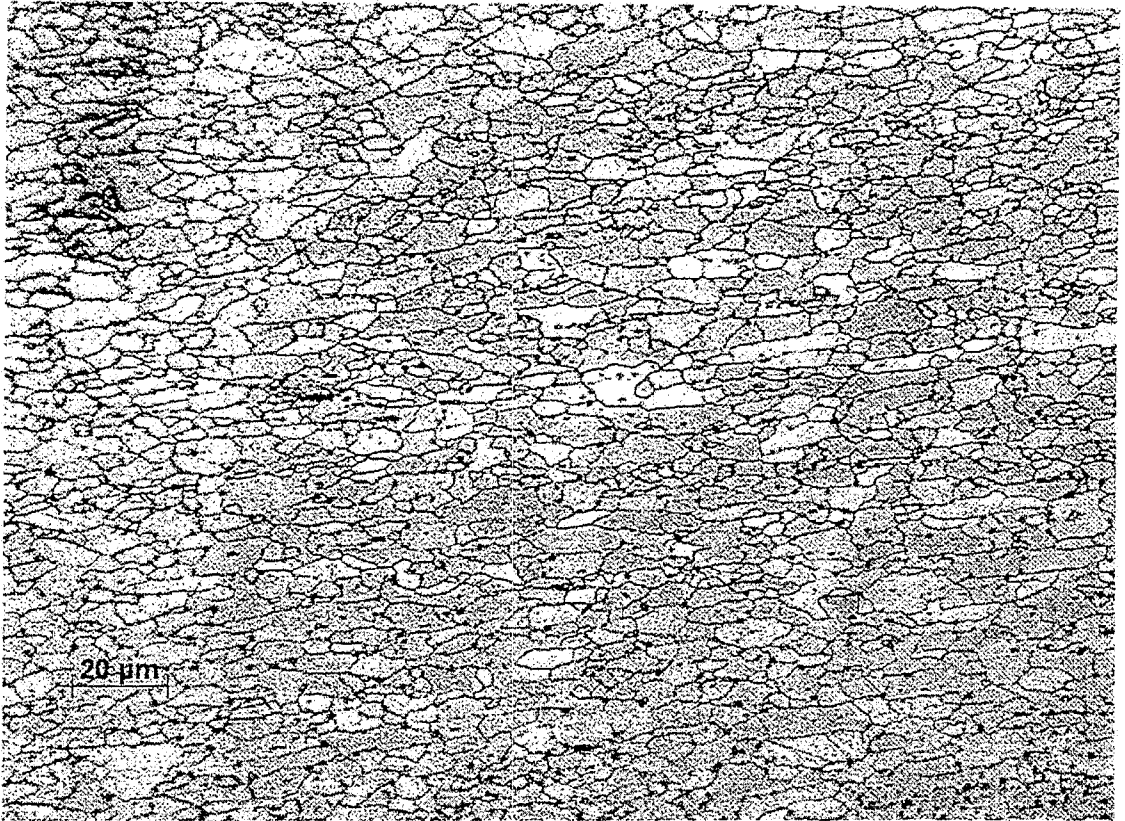

Figure 24

REFERENCES CITED IN THE DESCRIPTION

This list of references cited by the applicant is for the reader's convenience only. It does not form part of the European patent document. Even though great care has been taken in compiling the references, errors or omissions cannot be excluded and the EPO disclaims all liability in this regard.

Patent documents cited in the description

- US 4095544 A [0003] [0005]
- EP 542552 A [0012]

Szabadalmi igénypontok

1. Húzott és nyújtáshúzott fém doboz test (110), amely úgy van kialakítva, hogy doboz végre (120) van peremezve, a doboz test (110) tartalmaz: nyújtáshúzott oldalfalat, amelynek van karimája (111), amely képes arra, hogy kétszeresen peremezve legyen doboz vég peremhez; és
- 5 nem öblös, zárt bázisa (124), amely integrálisan van kialakítva az oldalfallal, a bázis (124) tartalmaz kerületi kúpos mélyedést (134) és fenék falat (130) radiálisan a kúpos mélyedésen belől (134),
 azzal jellemezve, hogy a doboz test átlagos Rockwell keménységi száma 64 és 70 között van, bázis nyújtással volt hidegen keményítve, és szemcséknek a bázis bádogban átlagos oldalaránya legalább 1,4.
- 10 2. Az 1. igénypont szerinti doboztest, ahol a szemcséknek a bázis bádogban átlagos oldalaránya 1,5 és 2,5 közötti.
3. Az 1. vagy 2. igénypont szerinti doboztest, ahol a szemcséknek a bázis bádogban átlagos oldalaránya 1,6 és 2,2 közötti.
4. A 3. igénypont szerinti doboztest, ahol a szemcséknek a bázis bádogban átlagos oldalaránya
 15 közelítőleg 1,8.
5. Eljárás húzott és nyújtáshúzott fém doboz test (110) előállítására, amely úgy van kialakítva, hogy doboz végre (120) van peremezve, a doboz test (110) tartalmaz: nyújtáshúzott oldalfalat, amelynek van karimája (111), amely képes arra, hogy kétszeresen peremezve legyen doboz vég peremhez; és
 nem öblös, zárt bázisa (124), amely integrálisan van kialakítva az oldalfallal,
 20 azzal jellemezve, hogy a bázis (124) nyújtással van keményítve nyers fém lemezből (10), amely a nyers lemez Rockwell keménységi számának legalább 7%-os átlagos változását eredményezi.
6. Az 5. igénypont szerinti eljárás húzott és nyújtáshúzott fém doboz test (110) előállítására, ahol a az átlagos Rockwell keménységi szám növekedése 8% és 21 % között van.
7. Az 5. vagy 6. igénypont szerinti eljárás húzott és nyújtáshúzott fém doboz test (110) előállítására,
 25 ahol az átlagos Rockwell keménységi szám növekedése 10 % és 16 % között van.
8. Az 5-7. igénypontok bármelyike szerinti eljárás húzott és nyújtáshúzott fém doboz test (110) előállítására, ahol az átlagos Rockwell keménységi szám növekedése 12 % és 15 % között van.