



INTERNATIONAL APPLICATION PUBLISHED UNDER THE PATENT COOPERATION TREATY (PCT)

<p>(51) International Patent Classification⁶ : A61C 13/00, 8/00</p>	<p>A1</p>	<p>(11) International Publication Number: WO 99/32045</p> <p>(43) International Publication Date: 1 July 1999 (01.07.99)</p>
<p>(21) International Application Number: PCT/CA97/00984</p> <p>(22) International Filing Date: 18 December 1997 (18.12.97)</p> <p>(71)(72) Applicant and Inventor: POIRIER, Michel [CA/CA]; 1, chemin Normandie, Sainte-Agathe-des-Monts, Quebec J8C 2G5 (CA).</p> <p>(74) Agents: ANGLEHART, James et al.; Swabey Ogilvy Renault, Suite 1600, 1981 McGill College Avenue, Montreal, Quebec H3A 2Y3 (CA).</p>	<p>(81) Designated States: AL, AM, AT, AU, AZ, BA, BB, BG, BR, BY, CA, CH, CN, CU, CZ, DE, DK, EE, ES, FI, GB, GE, GH, HU, ID, IL, IS, JP, KE, KG, KP, KR, KZ, LC, LK, LR, LS, LT, LU, LV, MD, MG, MK, MN, MW, MX, NO, NZ, PL, PT, RO, RU, SD, SE, SG, SI, SK, SL, TJ, TM, TR, TT, UA, UG, US, UZ, VN, YU, ZW, ARIPO patent (GH, GM, KE, LS, MW, SD, SZ, UG, ZW), Eurasian patent (AM, AZ, BY, KG, KZ, MD, RU, TJ, TM), European patent (AT, BE, CH, DE, DK, ES, FI, FR, GB, GR, IE, IT, LU, MC, NL, PT, SE), OAPI patent (BF, BJ, CF, CG, CI, CM, GA, GN, ML, MR, NE, SN, TD, TG).</p> <p>Published <i>With international search report.</i></p>	

(54) Title: MANUFACTURING A DENTAL IMPLANT DRILL GUIDE AND A DENTAL IMPLANT SUPERSTRUCTURE

(57) Abstract

Dental implant drill holes and the shape of a dental implant superstructure are chosen by creating a computer model giving jawbone structural details, gum surface shape information and proposed teeth or dental prosthesis shape information. The computer model shows the bone structure, gum surface and teeth images properly referenced to one another so that implant drill hole positions can be selected taking into consideration proper positioning within the bone as well as proper positioning with respect to the dental prosthesis. Similarly, manufacture of the dental implant superstructure used for fixed dental prosthesis or overdentures can be designed based on knowledge of the actual implant positions referenced to an image of the gum surface and proposed dental prosthesis.

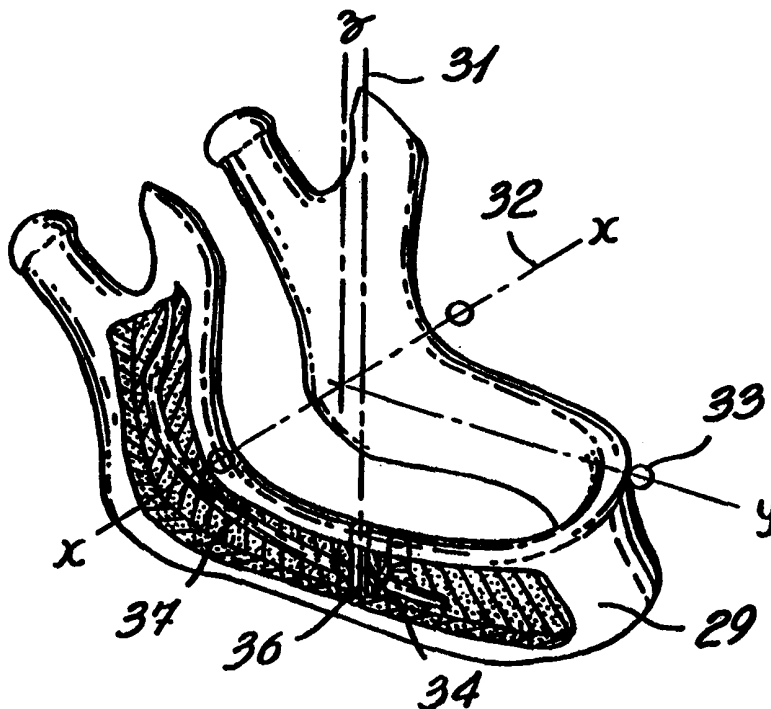

FOR THE PURPOSES OF INFORMATION ONLY

Codes used to identify States party to the PCT on the front pages of pamphlets publishing international applications under the PCT.

AL	Albania	ES	Spain	LS	Lesotho	SI	Slovenia
AM	Armenia	FI	Finland	LT	Lithuania	SK	Slovakia
AT	Austria	FR	France	LU	Luxembourg	SN	Senegal
AU	Australia	GA	Gabon	LV	Latvia	SZ	Swaziland
AZ	Azerbaijan	GB	United Kingdom	MC	Monaco	TD	Chad
BA	Bosnia and Herzegovina	GE	Georgia	MD	Republic of Moldova	TG	Togo
BB	Barbados	GH	Ghana	MG	Madagascar	TJ	Tajikistan
BE	Belgium	GN	Guinea	MK	The former Yugoslav Republic of Macedonia	TM	Turkmenistan
BF	Burkina Faso	GR	Greece	ML	Mali	TR	Turkey
BG	Bulgaria	HU	Hungary	MN	Mongolia	TT	Trinidad and Tobago
BJ	Benin	IE	Ireland	MR	Mauritania	UA	Ukraine
BR	Brazil	IL	Israel	MW	Malawi	UG	Uganda
BY	Belarus	IS	Iceland	MX	Mexico	US	United States of America
CA	Canada	IT	Italy	NE	Niger	UZ	Uzbekistan
CF	Central African Republic	JP	Japan	NL	Netherlands	VN	Viet Nam
CG	Congo	KE	Kenya	NO	Norway	YU	Yugoslavia
CH	Switzerland	KG	Kyrgyzstan	NZ	New Zealand	ZW	Zimbabwe
CI	Côte d'Ivoire	KP	Democratic People's Republic of Korea	PL	Poland		
CM	Cameroon	KR	Republic of Korea	PT	Portugal		
CN	China	KZ	Kazakstan	RO	Romania		
CU	Cuba	LC	Saint Lucia	RU	Russian Federation		
CZ	Czech Republic	LI	Liechtenstein	SD	Sudan		
DE	Germany	LK	Sri Lanka	SE	Sweden		
DK	Denmark	LR	Liberia	SG	Singapore		
EE	Estonia						

**MANUFACTURING A DENTAL IMPLANT DRILL GUIDE
AND A DENTAL IMPLANT SUPERSTRUCTURE**

Field of the Invention

5 The present invention relates to a method of manufacturing a dental implant drill guide. The invention also relates to a method of manufacturing a dental implant superstructure.

10 **Background of the Invention**

 It is known in the art to secure dental prostheses using dental implants secured in the upper or lower jawbone. It is also known in the art to mount a framework or superstructure to a number of implants, the superstructure being used to evenly support a set of false teeth or denture prostheses. Accurate placement within the jawbone of the implants is a difficult task. In International Patent Application No. PCT/IT94/00059, published 24 November 1994 as WO 94/26200, there is described an adjustable guiding device for positioning dental implants in which it is possible for the dental surgeon to adjust a drill axis for each implant before proceeding to use the guiding device or drill template to guide the surgeon's drill for the purposes of preparing the drill hole for the implant. The guiding device disclosed in the International publication helps the dental surgeon to decide on the drill axis after viewing radiographic images of the radio-opaque tubular drill guide superposed the bone structure.

 In the known prior art, the oral surgeon typically has difficulty deciding on a drill axis for the implants since the ideal position for the implants should be decided with knowledge of the jawbone structure into which the implant is to be inserted, knowledge of the position within the jawbone structure of the nerve tissue, the gum surface and the required position and dimensions of the false teeth or dentures

to be supported by the dental implant. Of course, in the conventional manner of selecting the implant axis, the dentist or dental surgeon simply makes a best guess in light of his knowledge of the patient. Of course, this leads, in certain cases, to imperfections in the dental prosthesis. The imperfections may be lack of ideal support, unfavorable angulation of an implant causing a weakness in the implant which may cause failure over time, or a visually perceptible defect in the appearance of the prosthesis.

In the conventional method for the construction of the superstructure, a physical model of the patient's gums and dental implant heads is prepared on which the superstructure is built manually using molding and other techniques known in the art. The craftsman or technician skilled at manufacturing such dental superstructures takes into consideration the size and shape of the desired dentures to be placed over the superstructure when crafting the same. The procedure for manufacturing dental implant superstructures as is conventionally known in the art is time-consuming and sometimes results in imperfect structures or defects in the visual appearance of the dentures to be placed over the superstructure.

In U.S. Patent 5,401,170 granted March 28, 1995 to Nonomura, there is disclosed a method and apparatus for measuring by camera image the implant heads of the implants in the patient's mouth for the purposes of cutting a frame on which the prosthetic teeth will be arranged and baked. In the method disclosed, the construction of the frame or superstructure is carried out in the absence of a reference to the shape and position of the patient's ideal teeth position. Thus, as the dentures or artificial teeth are crafted on the frame or superstructure, care would be required during the manual process to ensure that the position of the

teeth on the frame will match the opposed set of teeth in the patient's mouth.

Objects of the Invention

5 It is a first object of the present invention to provide a method of manufacturing a dental implant drill guide or drill template which will result in a precise and accurate drill guide for selected drill holes. It is furthermore an object of the present
10 invention to provide a method of manufacturing a dental implant superstructure in which information concerning the position of a plurality of dental implants mounted in a jawbone, the gum surface covering the jawbone and the fixed denture shape is
15 all taken into consideration during the specification of the shape of the superstructure before the superstructure is precision made.

 It is yet another object of the present invention to provide such methods which provide better
20 accuracy and faster results than conventional methods.

 It is yet another object of the present invention to provide a dental implant drill guide which is precise and easy to use such that drilling of the dental implant holes does not require expert skill
25 and knowledge beyond the skill of basic dental surgery. It is furthermore an object of the present invention to provide tools which will reduce the number of visits a patient needs to make to the dental surgeon in order to have dental implants and a dental
30 implant superstructure inserted.

Summary of the Invention

 According to a first aspect of the invention, there is provided a method of manufacturing a dental
35 implant drill guide, comprising the steps of: (a) imaging a jawbone and tissue structure with a reference to a gum surface to produce a three-

dimensional computer graphics model; (b) selecting at least one implant drill hole position for at least one dental implant using the said mode, the position being specified in three dimensions, including a hole termination point and orientation, and being referenced to the gum surface reference; (c) entering at least one set of implant drill hole position coordinates into a CNC device; (d) providing a drill template body having a first surface for mating with a gum surface of the jawbone; and (e) using the CNC device to provide a fixed orientation drill guide socket in the template body for each one of the at least one drill hole positions entered in step (c) with a corresponding position and orientation.

According to a second aspect of the present invention, there is provided a method of manufacturing a dental implant superstructure having a plurality of dental implant abutting flanges and a gum tissue overlying bridge to which a dental prosthesis can be attached, the method comprising the steps of: (a) obtaining an image of a gum surface; (b) obtaining an image of dentures or teeth to be placed over the gum surface; (c) obtaining dental implant position data defining a position and angular orientation of a plurality of dental implants mounted in a jawbone covered by the gum surface; (d) referencing the gum surface image, the teeth or denture image and the implant position data with respect to a common frame of reference; (e) generating a computer graphics model of the gum surface, the dentures or teeth and the dental implants; (f) selecting a shape of the overlying bridge using the model and specifying shape data; and (g) entering the shape data into a precision superstructure manufacturing device.

In the method of manufacturing a dental implant drill guide according to the present invention, the patient is typically edentured, namely, the patient

- 5 -

has had all teeth pulled from the jawbone, and the jawbone has been given time to heal since the teeth were pulled. If the patient decides to proceed with dental implants and the placement of a superstructure for solidly securing dentures over the gum, a period of about 12 months is provided for from the time of pulling any remaining teeth from the jawbone before proceeding with the operation of inserting implants into the jawbone.

10 A medical image of the jawbone and tissue structure is obtained by using x-ray imaging, MRI or possibly nuclear imaging techniques to produce a three-dimensional computer graphics model which has a reference to the gum surface or some other fixed reference with respect to the patient's jawbone. Preferably, a radiographic scanner guide is used which is molded to conform to the shape of the patient's gums and which includes radio-opaque spheres whose positions with respect to the gum surface is known.

20 The primary advantage of the invention is that the oral surgeon may select the optimum position for dental implants using the three-dimensional computer graphics model of the jawbone and tissue structure. Selection of the drill hole positions using the computer graphics model is transferred to a CNC device for the purposes of providing fixed drill guide sockets in the template body for each one of the drill hole positions or position selected using the computer graphics model. While the model is three-dimensional, it may be convenient for the purposes of selecting the drill hole axis to use a two-dimensional representation of the jawbone and tissue structure, the two-dimensional view being displayed with a user controlled slice angle. Preferably, the dental surgeon will select the position for each implant drill hole, not only to position the implant in the optimum location within the jawbone, but also to

result in a position of support which is suitable for supporting the dentures. Therefore, it is preferred to display, in addition to the three-dimensional computer graphics model of the jawbone and tissue structure, the patient's dentures in the proper spatial relationship with respect to the jawbone and tissue structure. This requires imaging the patient's dentures or teeth, and possibly gum structure, in addition to the jawbone and tissue structure, in such a way that all images are referenced with respect to one another to be integrated into the same three-dimensional computer graphics model.

While it would be possible to prepare the drill template body and provide it with the drill guide sockets using the CNC device, the drill template body is preferably molded on a physical model of the gum surface into which model the CNC device has previously drilled the desired implant drill holes. The drill holes in the physical model are used to build a mold for the drill guide sockets. This prevents the need to use the CNC device to produce fine details except for the precision drilling of the drill holes.

Imaging of the dentures or teeth to be placed over the gum surface and the imaging of the gum surface can be carried out by using laser camera imaging techniques known in the art. These images are preferably obtained using a physical model of the patient's gum surface, and the physical model is imaged in such a way that the images can be referenced accurately to the jawbone and tissue structure images.

In the method of manufacturing the dental implant superstructure according to the invention, the actual dental implant position data is obtained preferably by taking an imprint using transfers connected to the implants. Preferably, the imprint is taken using the same drill guide according to the invention with the sockets of the drill guide being

- 7 -

large enough to receive the transfers and surrounding
imprint material. Preferably, the positions and
orientations of the transfers are physically measured
along with a reference to the drill guide which will
5 permit the relative positions of the implants to be
known with a reference to a standard frame of
reference. Using the standard frame of reference, it
is possible to generate a computer graphics model of
the gum surface, dentures or teeth and dental implants
10 which allows the dental surgeon or technician to
select the best shape for the overlying bridge of the
superstructure.

In the case of a fixed dental prosthesis which
is implant mounted (i.e. porcelain on metal), the
15 ideal form of the superstructure can be automatically
designed using the computer model taking into
consideration the form of the laser camera imaged
teeth and by subtracting a thickness of porcelain
which the technician requires to recreate the shape of
20 the imaged teeth. In the case of a dental prosthesis
supported by a superstructure (overdenture), the shape
of the superstructure can be automatically determined
by taking into account the external shape of the
prosthesis and by circulating the superstructure
25 inside the prosthesis, making sure that the necessary
thickness of prosthesis material (e.g. acrylic) will
be available all around in order to provide a
adequately strong prosthesis.

When precision forming the superstructure, it
30 is possible to use various techniques. In one
embodiment, the entire superstructure is cut using a
CNC milling machine programmed to cut according to the
shape data specified using the computer model. In
another embodiment, the shape data is used to specify
35 a 3D wax model prepared using stereolithographic
techniques so that the superstructure can then be cast
and then the abutments precision milled with a CNC

milling machine. The casting metal may be titanium. In yet another embodiment, a CNC drilling machine could be equipped with a precision drill bit and used to provide a model with precision positioned implant abutment cavities. The shape of the superstructure can then be "crafted" by manually preparing the cavities for the rest of the superstructure in the model. Such crafting can be guided by the computer model. The superstructure can then be cast in the model and finished, with the abutments in precise position.

Brief Description of the Drawings

Other objects and features of the present invention will be better understood by way of the following detailed description of the preferred embodiment with reference to the appended drawings in which:

Figure 1 is a perspective view of an articulator supporting a physical model of a patient's upper and lower gums with dentures in place;

Figure 2 is a perspective view similar to Figure 1 in which the dentures have been replaced by a radiographic scanning guide;

Figure 3 is a perspective view of the radiographic scanning guide;

Figure 4 is a perspective view of a three-dimensional computer model of a patient's lower jawbone shown partly broken away with the radio-opaque reference spheres and reference coordinate superimposed;

Figure 5 is a flow diagram of the method of manufacturing the dental implant drill guide according to the preferred embodiment;

Figure 6 is a panoramic view of a lower jawbone of a patient with the gum line and dentures superimposed;

Figure 7 is a cross-sectional view about line 7 of Figure 6;

Figure 8 is a block diagram of the CNC drill device and data entry terminal;

5 Figure 9 is a perspective view of a five axis CNC drill device;

Figure 10 is a front view of a physical model with four drill axes shown;

10 Figure 11 is a view similar to Figure 10 in which a drill guide has been molded with the fixed drill sockets formed by pins inserted in the drill holes;

Figure 12 is a perspective view of the drill guide according to the preferred embodiment;

15 Figure 13 is a sectional view of the drill guide being used to drill a patient's jawbone;

Figure 14 is an enlarged sectional view of a jawbone having received an implant with the drill guide placed on top of the gum surface to act as an impression tray for the purposes of taking an exact imprint of the implant position using a transfer;

20 Figure 15 is a flow diagram of the method for machining a superstructure according to the preferred embodiment;

25 Figure 16 is a sectional view of a computer model illustrating the denture fit over the patient's gums with the implant head in correct relative position;

30 Figure 17 illustrates a similar computer graphics image as in Figure 16 for a position between two implants;

Figure 18 illustrates a perspective view of lower dentures and a lower superstructure; and

35 Figure 19 is a view from underneath the assembled components illustrated in Figure 18.

Detailed Description of the Preferred Embodiment

As illustrated in Figure 1, an articulator 20 as is known in the art is set up to support a lower physical model 21 and an upper physical model 22 of a patient's mouth with lower and upper dentures 23 and 24 supported by the physical model with the teeth of the dentures in proper alignment. The articulator is adjusted using the adjustment means 25 and 26 as is known in the art. As illustrated in Figure 2, the dentures 23 and 24 are removed and a scanner guide 27 is made by hand to fit exactly the space occupied by the upper and lower denture. Radio-opaque reference spheres 28 having a known diameter are bonded to the guide 27 with one sphere on each side at the rear and one in the front. In the illustration in the preferred embodiment, the spheres are shown near the lower jaw surface since it is the lower jaw that is to be imaged. The spheres could likewise be placed near the upper jaw surface as the case may be. The separated scanner guide body 27 is illustrated in Figure 3.

The particular advantage of the scanner guide 27 according to the present invention is that during radiographic scanning of the patient's jaw, the patient may comfortably hold the scanner guide 27 in place by closing down on the same. As can be appreciated, the lower jaw could move during imaging and must be secured by means such as the scanner guide 27. The patient's head is held in place during radiographic scanning using a suitable brace as is known in the art.

As shown in Figure 4, the result of the radiographic scanning is to obtain a three-dimensional computer graphics model 29 of the patient's lower jaw. Images of the reference spheres 28 appear as 33 and provide a reference to a coordinate axes 32. The dental surgeon is capable of viewing with the model 29

- 11 -

the nerve 37 which extends from the base of the jaw until it exits the jawbone at each side of the chin. A drill axis 31 for each proposed drill hole 34 is selected on the computer model. The end point of the
5 drill hole 36 is also selected.

For ease of selection of the drill axis 31, namely the position in space of the end point and the angular orientation of the drill axis 31, it may be possible to present slices of the computer model 29 to
10 the dental surgeon or technician which would make it easier to select the parameters. As can be appreciated, two angles are required to specify the orientation of the drill axis 31, for example, a first angle θ may define an angle of the drill axis 31 with
15 respect to the x-z plane and a second angular parameter ϕ may define the angle between the drill axis 31 in the z-y plane.

In the preferred embodiment, selection of the drill axes 31 for the drill holes 34 is done with
20 knowledge of the relative position of the gum surface and the relative position of the dentures or teeth. As illustrated in Figure 5, the 3-D computer model 29 is built up using the radiographic 3-D imaging data as well as referenced gum surface image data and
25 referenced denture image data. In Figure 6, there is shown a panoramic slice view of the 3-D model 29 showing the gum surface 44 and dentures 43 superposed the cortical bone structure 41 and the marrow 42.

As illustrated in Figure 7, in the preferred
30 embodiment, it is possible to view for a selected drill axis 31 the resulting implant position 49 and how this relates to the bone structure 41 and 42, the nerve 37, if present, as well as the lower and upper denture structure 44 and 43. As can be appreciated,
35 if the desired angle and position of the dentures with respect to the gum surface 46 would require an adjustment of the position and angle of the implant

49, the dental surgeon is able to select the optimum depth, position and angular orientation for the implant 49 relying entirely on the computer model. Once the hole termination position and angular orientation data for each of the drill holes is selected using the computer model, the data is entered through a data entry device 51 to control a CNC drill 52 in accordance with Figure 8 and as better illustrated in Figure 9.

The CNC drill 52 has a drill bit 53 which is capable of moving and drilling along a first vertical direction 54. The physical model 21 is mounted in such a way that it is able to turn about two directions 55 and 56 on a platform which is able to move in directions 57 and 60. The CNC drill 52 is capable of moving about five axes. In order for the CNC drill device to be properly referenced with respect to the physical model 21, the scanner guide may be placed on top of the physical model 21 and a coordinates measuring machine (CMM) connected to CNC drill 52 is used to accurately locate the position of each one of the position reference spheres and reference these to the CNC drill's reference frame. The CNC drill 52 is then programmed to convert the hole position and orientation data as referenced to the frame of reference of the computer model to the reference frame of the CNC drill so that the drill holes may be prepared in the physical model 21.

As illustrated in Figure 10, four drill holes 58 are cut into the physical model 21 which is mounted on a base 59. The drill hole axes 31 as shown are in different positions and orientations.

As shown in Figure 11, rods 62 are inserted into the holes 58. The socket forming mold parts 63 are placed over the rods 62 and a surrounding mold structure (not shown) is placed around the physical model 21 to allow for the molded guide body 61 to be

- 13 -

formed. Since the holes 58 are of different heights, the socket forming mold parts 63 are adjusted in size such that the distance between the circular flange edge and the end of the rods 102 is a constant. In this way, the circular flange edge 64 of the drill guide sockets is at a fixed distance with respect to the desired end point of the drill hole.

As shown in Figure 12, the finished molded drill guide body 61 has a plurality of drill guide tubes 66 inserted into the drill guide sockets 68, and three holes 67 are additionally provided for transitionally securing the drill guide 61 to the patient's jawbone during surgery. The drill guide tubes 66 may be removed and reinserted into the drill guide sockets 68 in order to change the internal diameter of the drill guide tubes as is required during surgery since the implant drill hole is started with a very small diameter drill bit and subsequently larger drill bits are used until the full size implant drill hole is obtained. As shown in Figure 13, the drill used in surgery is provided with a collar 69 for abutting against the upper surface of the guide tube 66 in such a way that the distance between the bottom of the collar 69 and the end of the drill bit 71 is fixed as required. In the preferred embodiment, the collar 69 is integral with the drill bit 71.

As can be appreciated, the oral surgeon prepares the implant holes using the drill guide 61 by removing circular portions of the gum (gingival taps) at the implant sites. In the conventional method of drilling implant holes, a procedure known as "flap surgery" is carried out in which a piece of the gum covering the jawbone where the implant hole is to be drilled is cut and peeled back so that the oral surgeon has clear access to the jawbone surface. Using the present invention, the surgeon has the option of doing flap surgery if required or

circumferential surgery as needed. Of course, if a conventional flap surgery is to be done, a modification of the surgical guide should be done, i.e. the guide should be removable as needed for flap surgery. In order to put the guide back at the same location, the use of transitional implants is needed to seat the guide after the flap is done. If the circular approach is chosen, there is no need to remove the guide during surgery, and by avoiding flap surgery, post operation healing time should be reduced.

As illustrated in Figure 14, the oral surgeon screws in an implant 72 into the hole made using drill guide 61. This can be done with the drill guide 61 remaining in place, the implants being inserted through the sockets 68. The upper surface of the implant 72 is approximately flush with the upper surface of the cortical exterior 41 of the jawbone. The implant 72 has a hollow threaded core. Since the implant 72 has been inserted into the jawbone tissue 42 by hand, its exact position may not be perfectly defined by the drill hole formed using the drill guide.

Once the implants have been secured in place, a transfer 73 is placed over the implant 72 and a central screw 76 is used to fasten the transfer 73 to the implant 72. An imprint material 74 is injected in the space between the drill guide cavity 68 and the transfer 73. The imprint material hardens after a short period of time and the oral surgeon or dentist removes the screws 76 which allows the drill guide 61 to be removed with the transfers 73 secured in place with a precise correspondence to the actual positions of the implants 72 in the patient's jawbone. As illustrated in Figure 15, the transfers securely lodged within the drill guide are used as a physical recording of the implant positions. The implants are

- 15 -

then capped with screws and the patient is typically given a period of a few months to recover from the insertion of the implants. During this time, the superstructure to be attached to the implants can be prepared.

As shown in Figure 15, the method for machining the superstructure according to the preferred embodiment requires measuring the actual implant position with reference to the gum surface. This is done by securing implant analogs (replicas of the implants) to each transfer. Then, with a special moldable stone material used in the art for producing oral cavity replicas, the analogs are embedded in the moldable stone material until it sets. After unscrewing all of the transfers from the analogs, a duplicate of the patient's mouth and positions of the implants is obtained. Extensions of the implants which are precisely machined to fit the analogs are screwed back into each analog and CMM measurements are made of the extensions. The extensions referred to as "targets" are used because the implant analog is typically too small for the CMM sensor and the target gives the technician additional surface to measure the top of the target and the sides. The position of each implant is then calculated knowing the position of each target, the targets being of precise known size and shape. It is noted that by changing the occluded (top) surface of the analogs, it is possible to measure the position of the implants by using the CMM directly on the analogs without using the said targets. It is also noted that the same measurement could be calculated by directly scanning the position of the analogs with the said laser scanning camera.

To be able to accurately superimpose the image of the gum surface and the image of the proposed teeth requires obtaining in addition to the positions of the actual implants, a fixed reference to the patient's

- 16 -

gum surface/jawbone. As can be appreciated, this can be achieved in many different ways. Known reference points may be provided on the drill guide and these can be measured when the drill guide is attached to the analogs on the stone physical model using the CMM apparatus. If the scanner guide is able to be fit securely over the gum surface of the physical model in which the implant analogs are embedded, the three spheres of the scanner guide can be measured before the targets are screwed in place.

Alternatively, the implant positions could be measured by attaching measurement targets directly to each transfer while measuring additionally reference points on the drill guide. This, however, poses the problem of solidly securing and mounting the drill guide to the CMM table.

The result of the CMM measurement starting with the transfers embedded in the drill guide is to obtain actual implant position data with a reference to the gum surface.

A 3-D computer model of the gum surface implant heads and teeth (overdentures) is then generated using the referenced gum surface image 38 and the referenced teeth image 39. Also, the original drill hole position data is entered into the 3-D computer model in order to monitor the shifts between the desired and the actual implant positions. This also permits the oral surgeon to confirm whether the actual implant positions are different in a way which could potentially create problems. It also serves to confirm that the measured actual implant positions are accurate.

As illustrated schematically in Figures 16 and 17, the 3-D computer model can be used to show sectional views transverse to the denture and upper jaw structure to illustrate the actual position of the implant, gum surface and teeth structure. As shown in

- 17 -

Figure 16, the implant head **49** will receive a superstructure consisting of an abutment foot **47** extending down to the top of the implant and having an upper bridge-like structure **48** extending inside the lower portion **44** of the denture structure and even possibly into the upper portion **43** of the denture structure. In between two implants, as illustrated in Figure 17, the bridge structure **48** is designed to be located above the gum surface **46** and within the denture structure. As can be appreciated, due to the confines and configuration of the patient's mouth, it may be necessary to shape the bridge structure **48** such that it passes close to either an inner or outer side wall of the denture structure **43, 44**. In this way, the denture technician is capable of viewing in the computer model how the bridge structure and superstructure is best constructed.

As shown in Figure 15, once the denture technician has selected the shape for the dental implant superstructure using the computer model, the shape data is passed on to a precision forming device for shaping the superstructure. In the preferred embodiment, a CNC milling machine similar to the CNC drill device illustrated in Figure 9 is used. The result is a superstructure as illustrated in Figure 17 which may be fastened directly to the dental implants. The superstructure illustrated in Figure 17 is of the type which receives dentures by snap-fit as is illustrated in Figure 18. The superstructure will be prepared from a solid piece of commercially pure titanium or any biocompatible material such as porcelain, preventing corrosion between implants and superstructure.

Alternatively, and especially when the shape of the superstructure is more complex, stereolithography is used to create a 3D superstructure in wax. The wax superstructure can be used according to known

- 18 -

techniques to obtain a cast titanium or titanium alloy superstructure body of the same shape. Precision holes and seats for the implants are then machined in the superstructure body using a 5-axis milling machine.

5

CLAIMS

1. A method of manufacturing a dental implant drill guide, comprising the steps of:
- 5 a) imaging a jawbone and tissue structure with a reference to a gum surface to produce a three-dimensional computer graphics model;
- b) selecting at least one implant drill hole position for at least one dental implant using said
10 model, said position being specified in three dimensions, including a hole termination point and orientation, and being referenced to said gum surface reference,
- c) entering at least one set of implant drill
15 hole position coordinates into a computer controlled precision manufacturing device;
- d) providing a drill template body having a first surface for mating with a gum surface of the jawbone;
- 20 e) using said precision manufacturing device to provide a fixed orientation drill guide socket in said template body for each one of said at least one drill hole position entered in step (c) with a corresponding position and orientation.
- 25
2. The method as claimed in claim 1, further comprising imaging denture prosthesis and including an image of said denture prosthesis in said model such that a position of said prosthesis with respect to
30 said jawbone can be seen, whereby said at least one implant drill hole position can be selected taking into account a position of said denture prosthesis with respect to said jawbone and tissue structure.
- 35 3. The method as claimed in claim 1, wherein said drill guide socket receives drill guide tubes having a variable internal diameter.

4. The method as claimed in claim 1, wherein said step (e) comprises drilling said implant drill holes into a physical model using a CNC drill device,
5 inserting a drill guide socket mold part into said physical model hole, providing a mold structure around said physical model and molding said drill template body to be formed with said fixed orientation drill guide socket in said body.
- 10
5. The method as claimed in claim 1, wherein said step (a) comprises preparing a scanner reference guide and carrying out radiographic imaging of said jawbone and tissue structure with said scanner reference guide
15 secured with respect to said gum surface, and converting said radiographic imaging into data to produce said three-dimensional computer graphics model.
- 20
6. A method of manufacturing a dental implant superstructure having a plurality of dental implant abutting flanges and a gum tissue overlying bridge to which a dental prosthesis can be attached, the method comprising the steps of:
- 25
- a) obtaining an image of a gum surface;
 - b) obtaining an image of dental prostheses to be placed over the gum;
 - c) obtaining dental implant position data defining a position and angular orientation of a
30 plurality of dental implants mounted in a jawbone covered by said gum surface;
 - d) referencing said gum surface image, said prostheses image and said implant position data with respect to a common frame of reference;
 - 35 e) generating a computer graphics model of said gum surface, said dentures and said dental implants;

- 21 -

f) selecting a shape of said overlying bridge using said model and specifying shape data;

g) entering said shape data into a precision manufacturing device to cut said superstructure.

5

7. The method as claimed in claim 6, wherein said precision manufacturing device is a CNC milling machine.

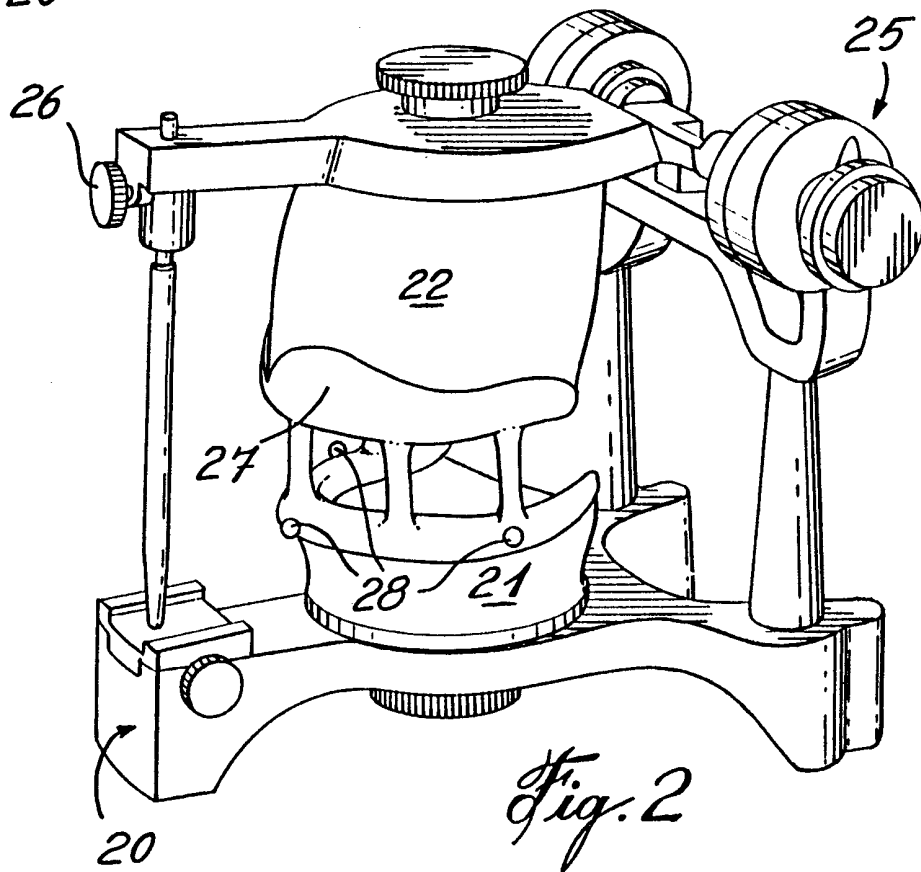
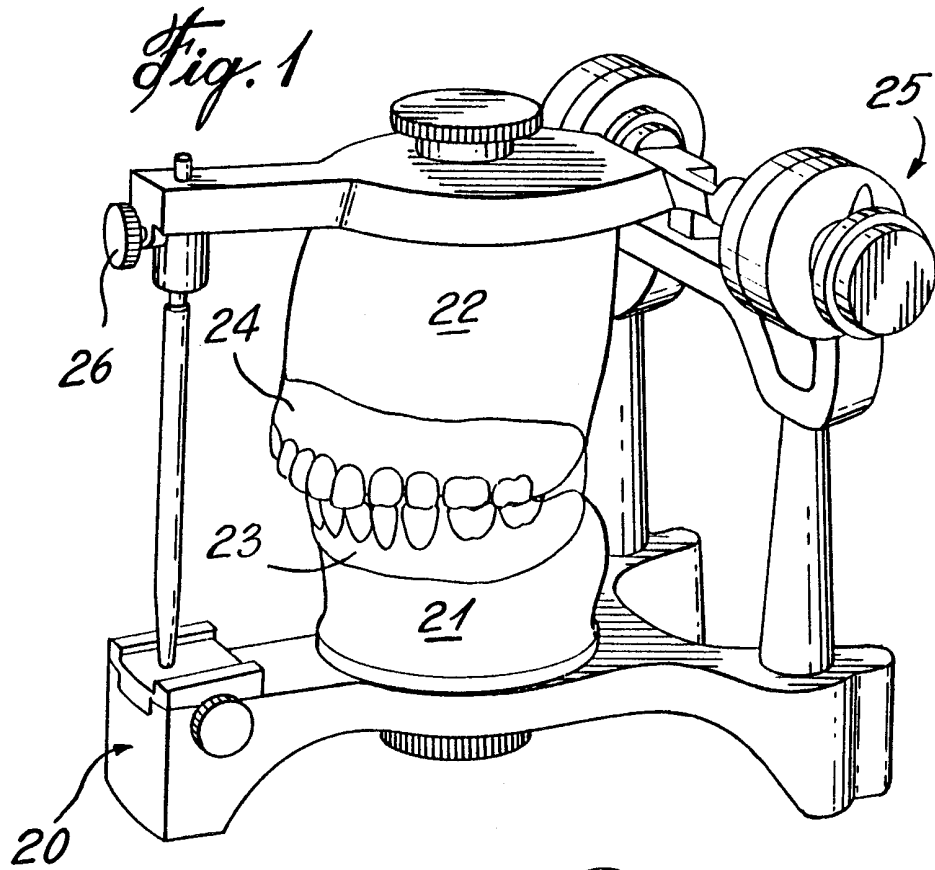

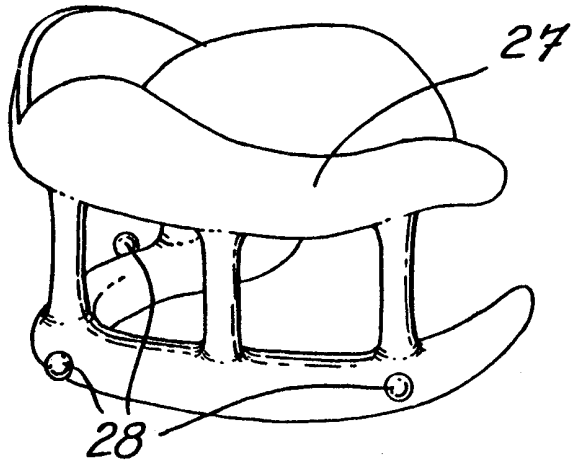

Fig. 3

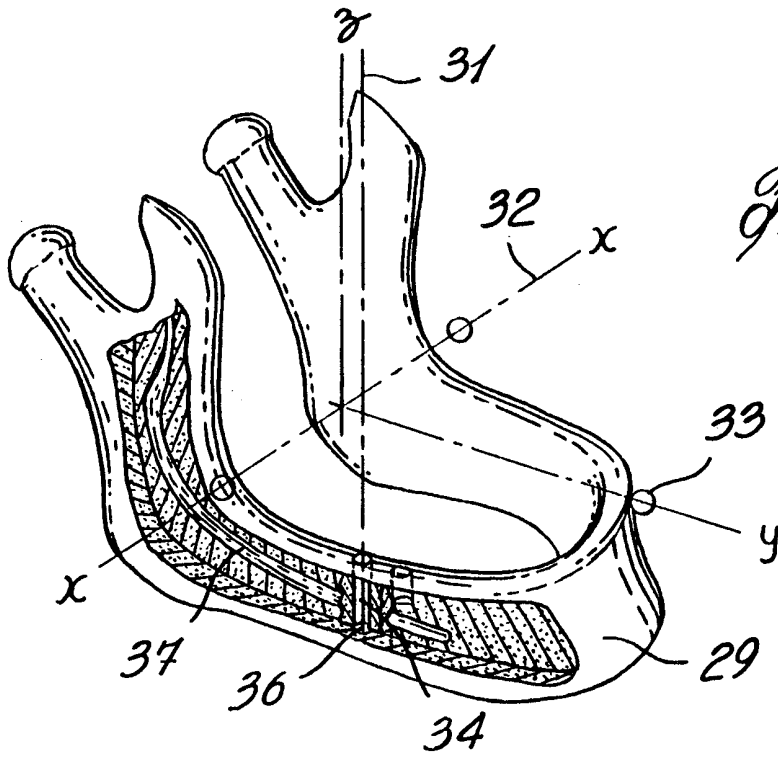

Fig. 4

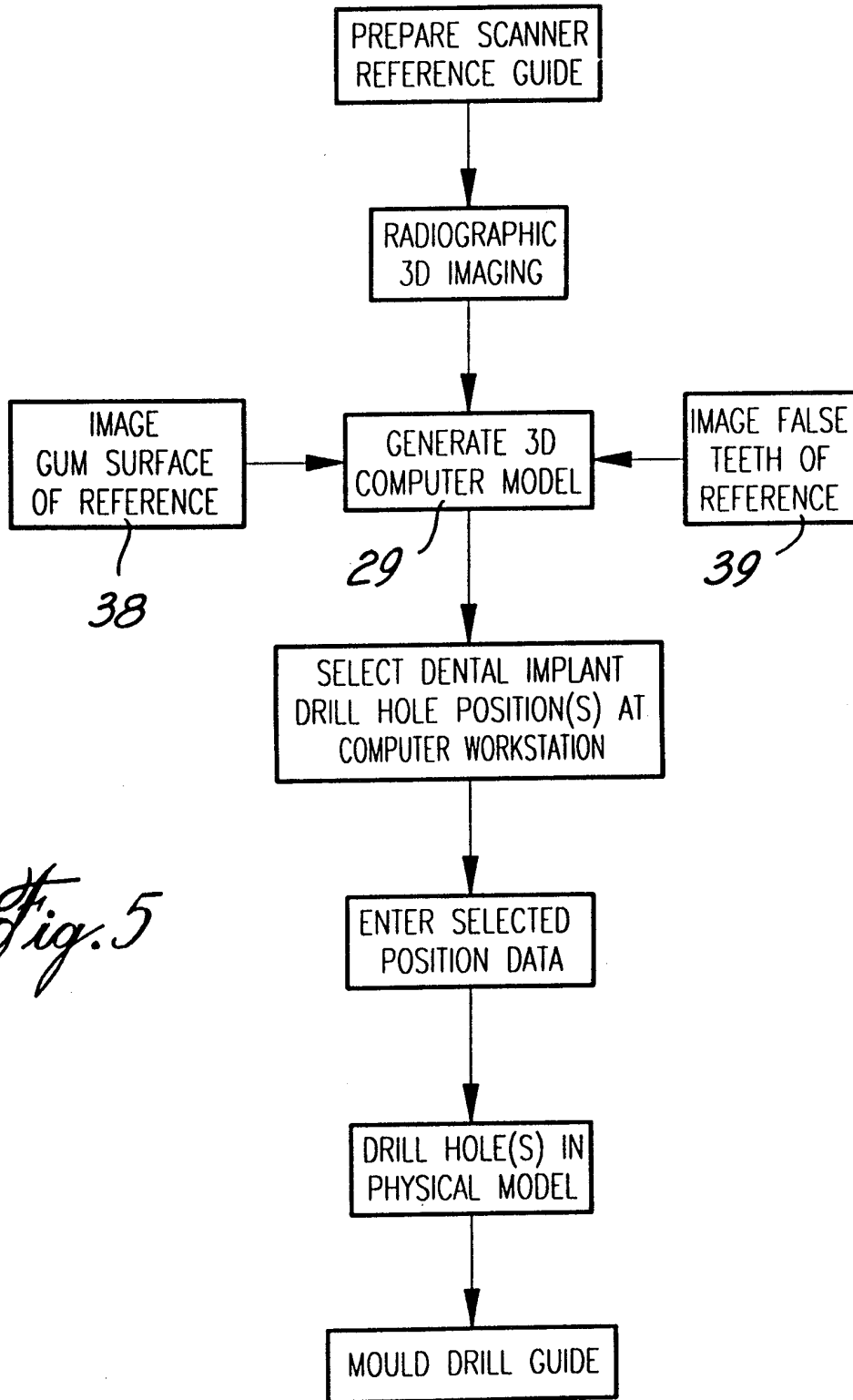

Fig. 5

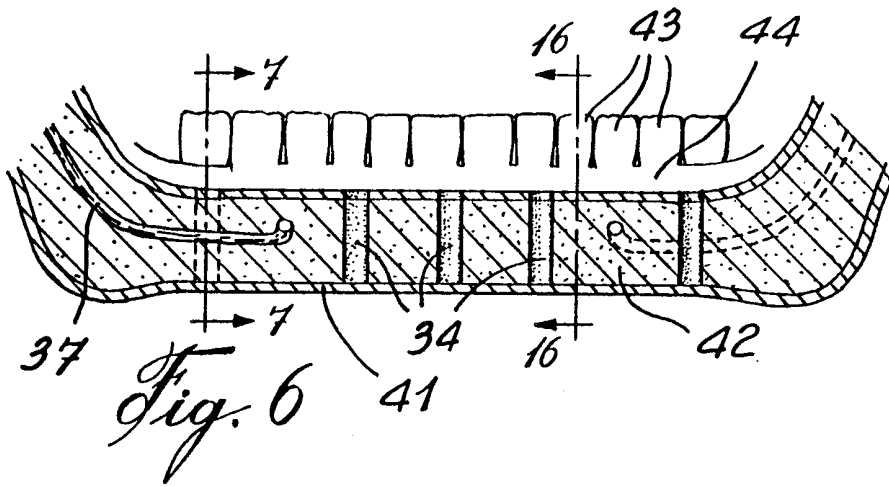

Fig. 6

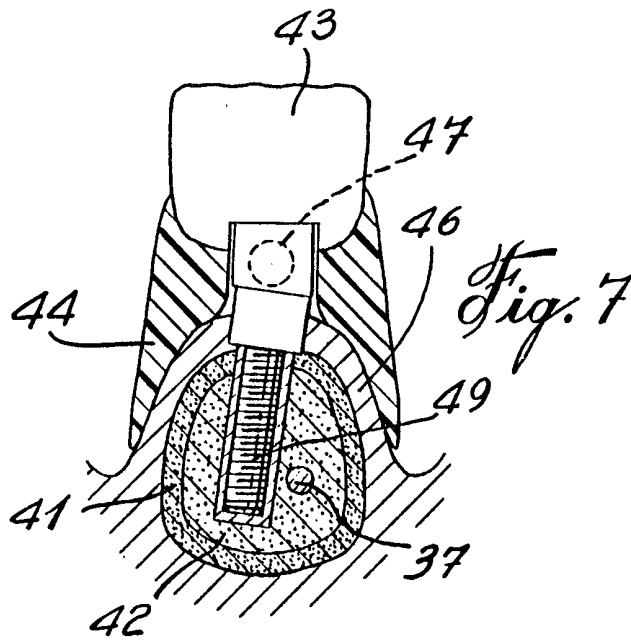
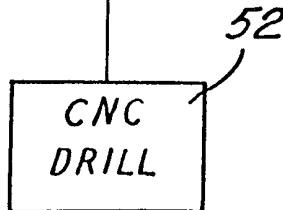

Fig. 7

- 1) x, y, z, θ, ϕ
- 2) x, y, z, θ, ϕ
- 3)

Fig. 8



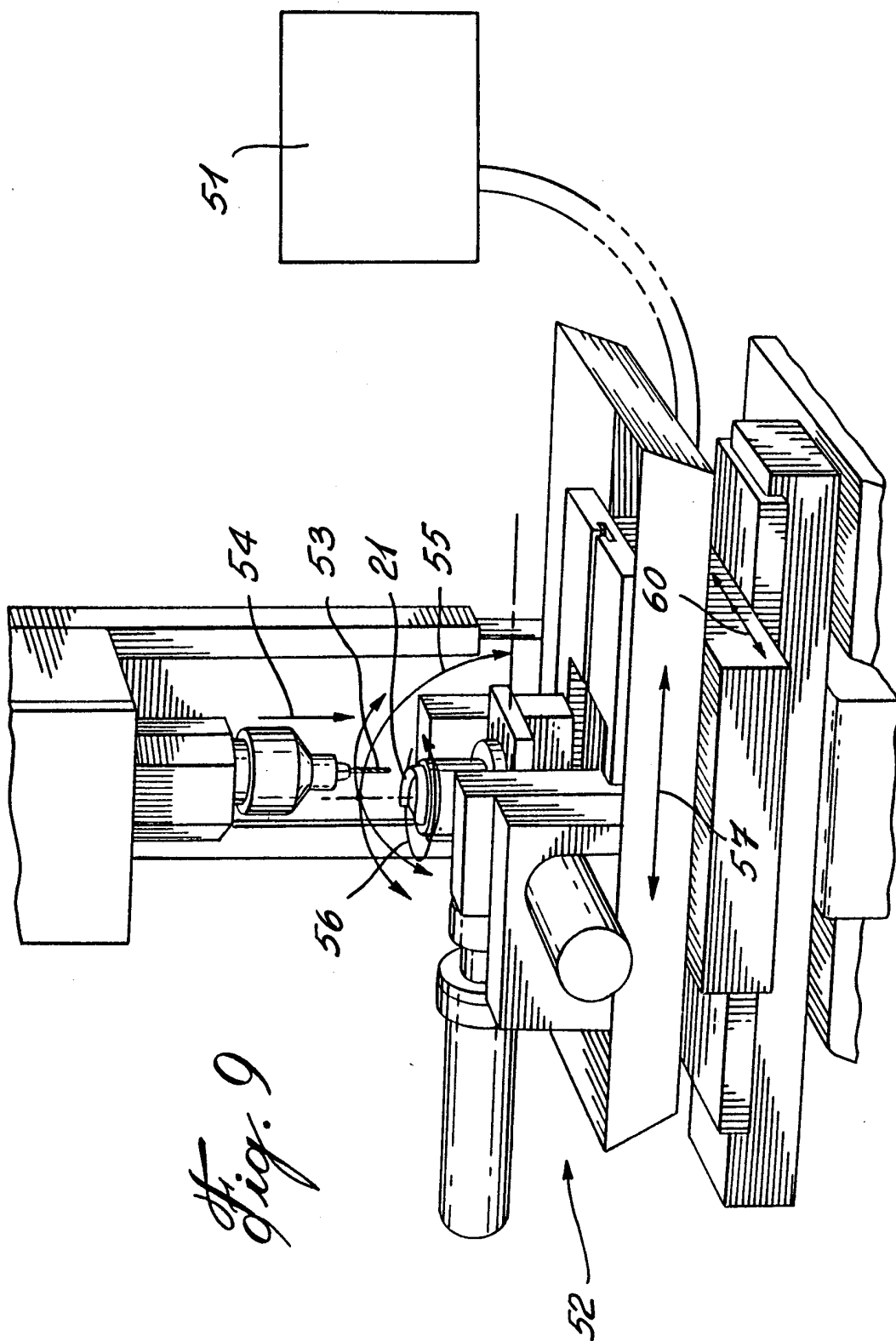
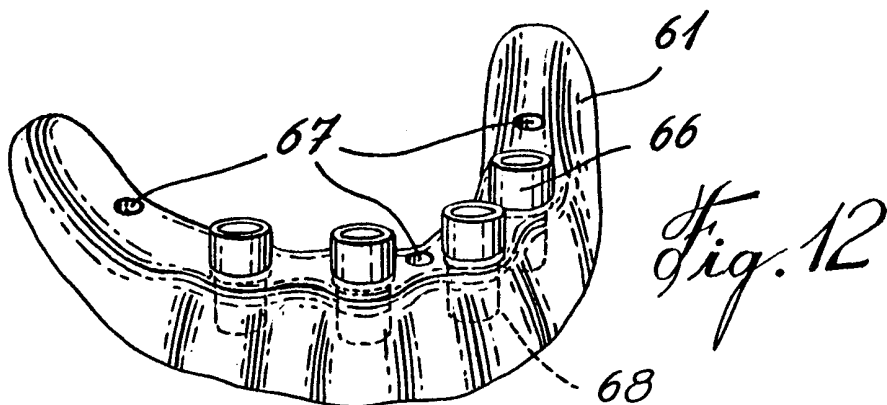
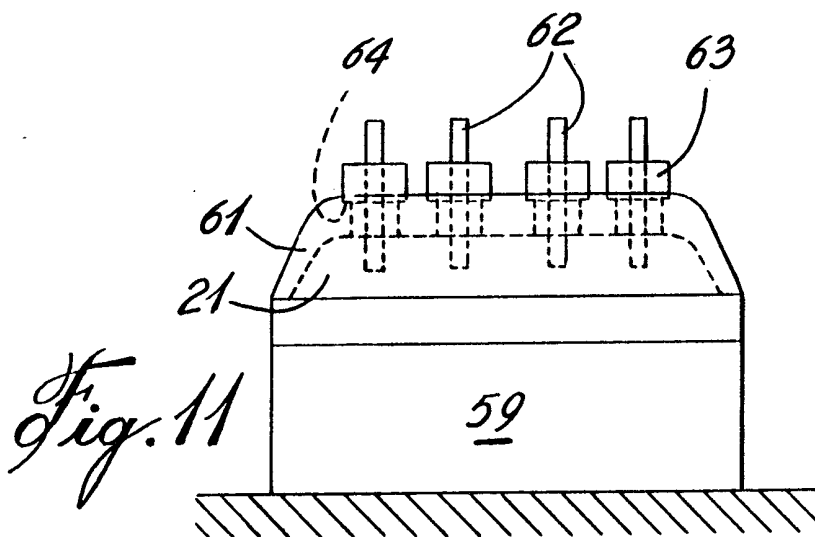
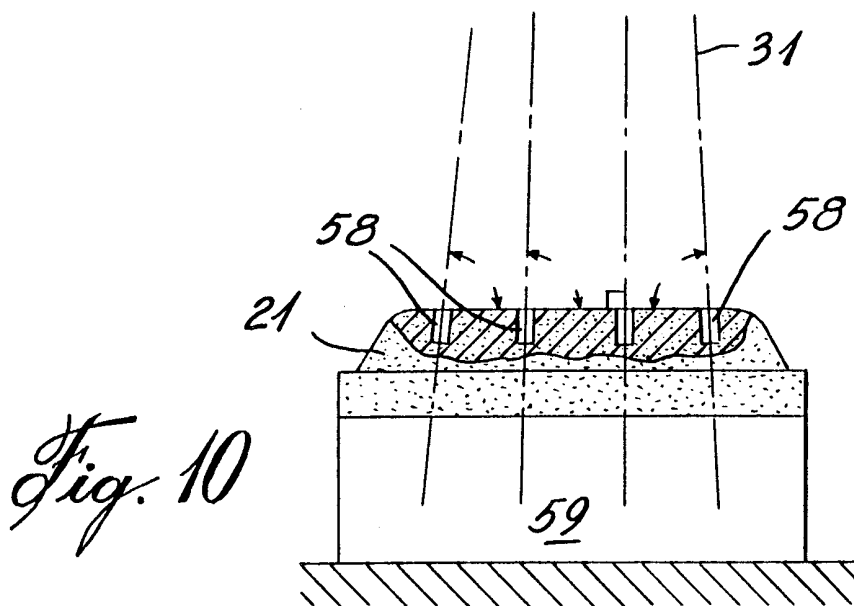

Fig. 9



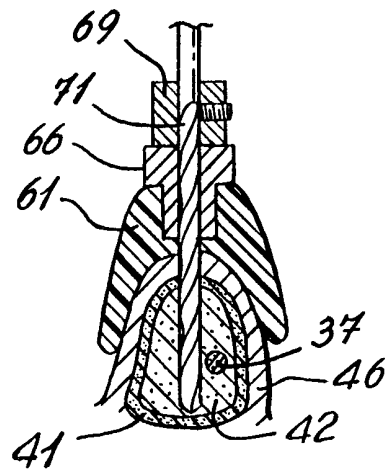

Fig. 13

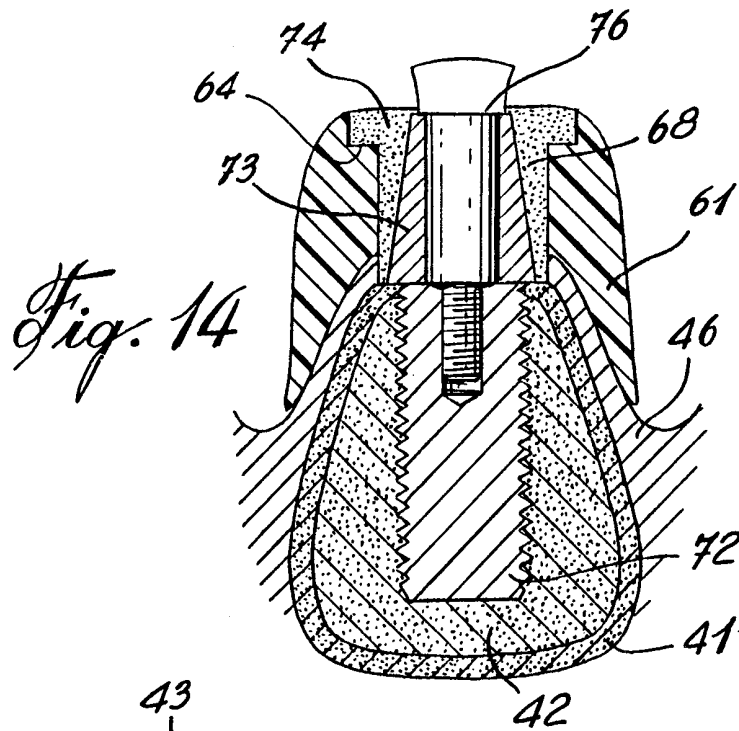

Fig. 14

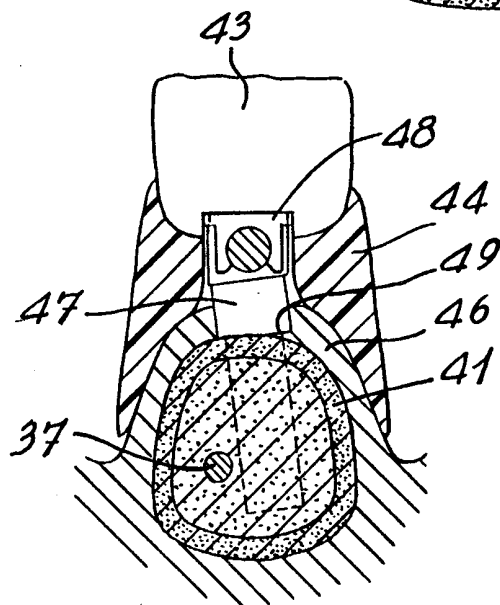
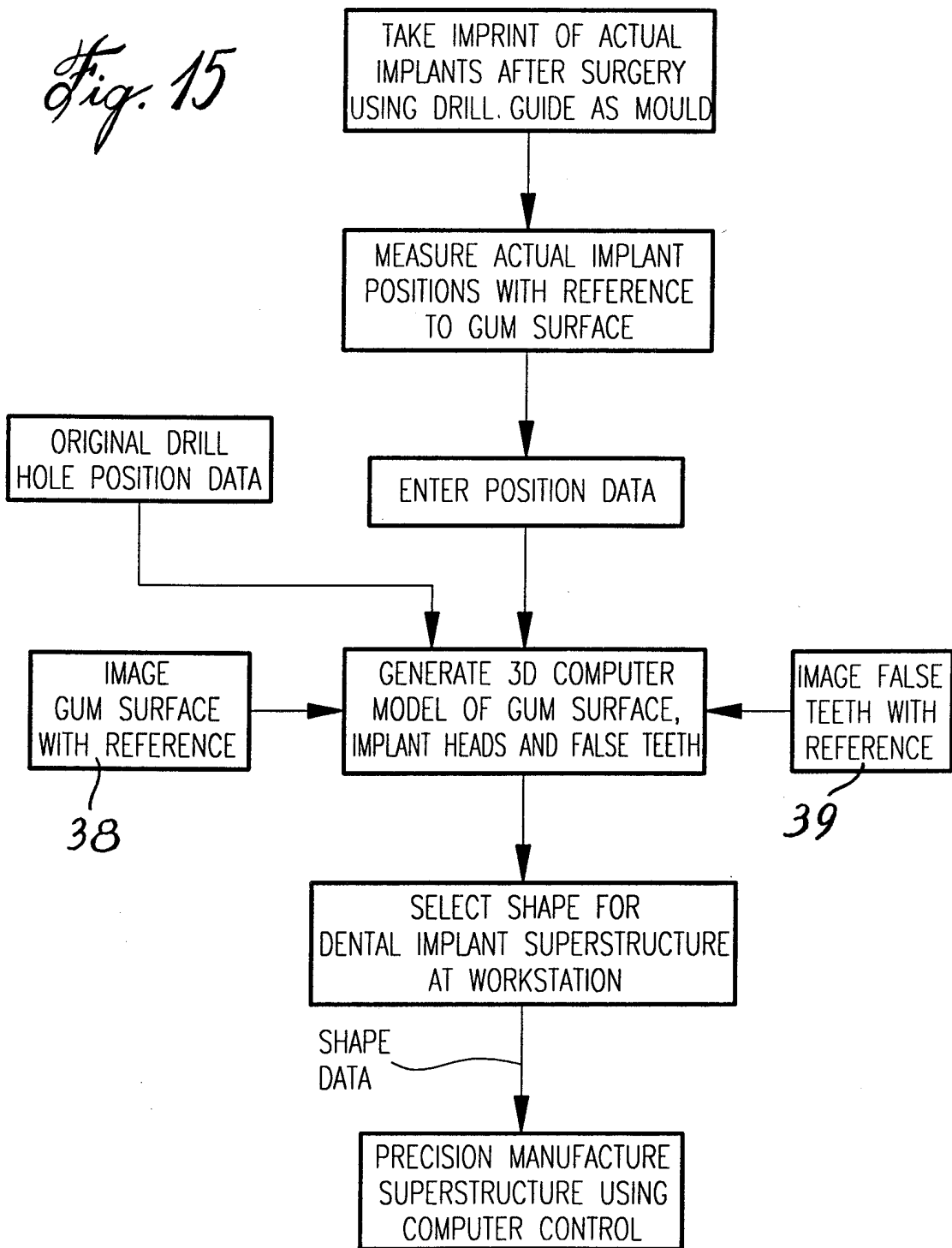
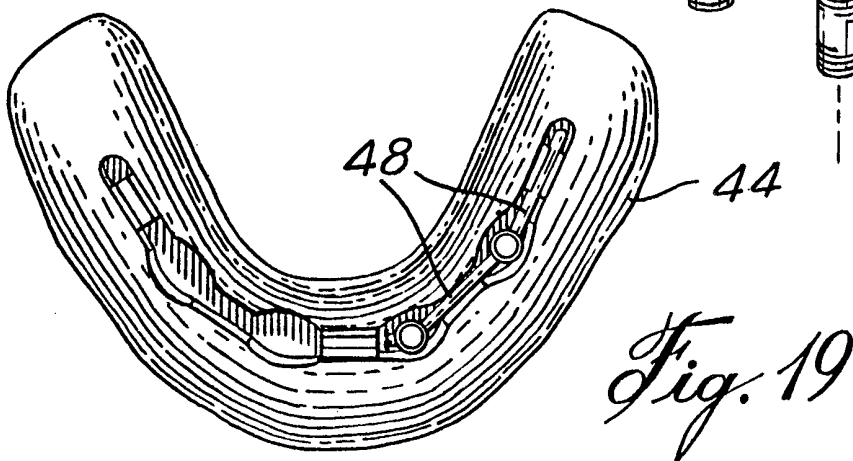
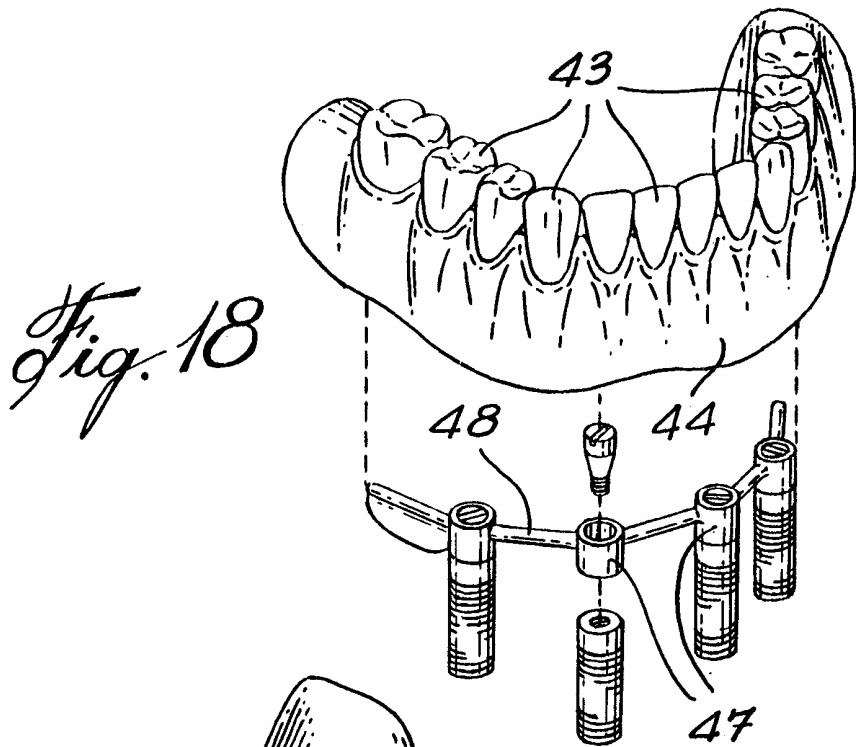
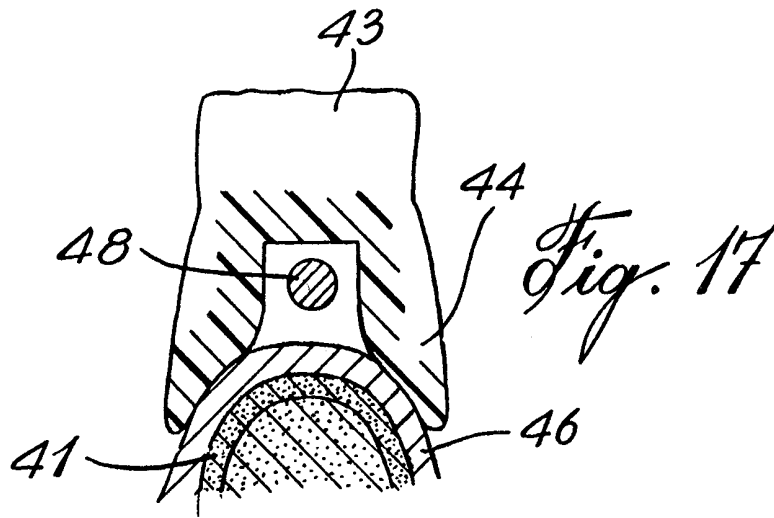

Fig. 16





INTERNATIONAL SEARCH REPORT

International Application No

PCT/CA 97/00984

A. CLASSIFICATION OF SUBJECT MATTER
 IPC 6 A61C13/00 A61C8/00

According to International Patent Classification (IPC) or to both national classification and IPC

B. FIELDS SEARCHED

Minimum documentation searched (classification system followed by classification symbols)

IPC 6 A61C

Documentation searched other than minimum documentation to the extent that such documents are included in the fields searched

Electronic data base consulted during the international search (name of data base and, where practical, search terms used)

C. DOCUMENTS CONSIDERED TO BE RELEVANT

Category	Citation of document, with indication, where appropriate, of the relevant passages	Relevant to claim No.
X	DE 195 10 294 A (BANNUSCHER RALF) 2 October 1996 see column 2, line 47 - column 3, line 22 see column 4, line 8-31 see column 4, line 61-65	1,4,5
A	---	2,3
X	US 5 527 182 A (WILLOUGHBY ANDREW J M) 18 June 1996 see column 51, line 4-25 see column 51, line 56 - column 52, line 31 see figures 16,17	6,7

	-/--	

Further documents are listed in the continuation of box C.

Patent family members are listed in annex.

Special categories of cited documents :

- "A" document defining the general state of the art which is not considered to be of particular relevance
- "E" earlier document but published on or after the international filing date
- "L" document which may throw doubts on priority claim(s) or which is cited to establish the publication date of another citation or other special reason (as specified)
- "O" document referring to an oral disclosure, use, exhibition or other means
- "P" document published prior to the international filing date but later than the priority date claimed

- "T" later document published after the international filing date or priority date and not in conflict with the application but cited to understand the principle or theory underlying the invention
- "X" document of particular relevance; the claimed invention cannot be considered novel or cannot be considered to involve an inventive step when the document is taken alone
- "Y" document of particular relevance; the claimed invention cannot be considered to involve an inventive step when the document is combined with one or more other such documents, such combination being obvious to a person skilled in the art.
- "&" document member of the same patent family

Date of the actual completion of the international search

25 August 1998

Date of mailing of the international search report

31/08/1998

Name and mailing address of the ISA
 European Patent Office, P.B. 5818 Patentlaan 2
 NL - 2280 HV Rijswijk
 Tel. (+31-70) 340-2040, Tx. 31 651 epo nl,
 Fax: (+31-70) 340-3016

Authorized officer

 Chabus, H

INTERNATIONAL SEARCH REPORT

International Application No

PCT/CA 97/00984

C.(Continuation) DOCUMENTS CONSIDERED TO BE RELEVANT		
Category	Citation of document, with indication, where appropriate, of the relevant passages	Relevant to claim No.
A	<p>DE 43 28 490 A (FRIEDMANN LEONID) 2 March 1995 see column 1, line 19-27 see column 3, line 23-50 see column 4, line 59 - column 5, line 8 see figures</p> <p style="text-align: center;">---</p>	1-6
E	<p>DE 196 29 708 A (MUELLER CHRISTIAN ;BONORDEN STEPHAN DR DR (DE); HUBER MICHAEL DR () 5 February 1998 see column 2, line 25-66 see column 7, line 30 - column 8, line 21; figures</p> <p style="text-align: center;">-----</p>	1,4,5

INTERNATIONAL SEARCH REPORT

Information on patent family members

International Application No

PCT/CA 97/00984

Patent document cited in search report	Publication date	Patent family member(s)	Publication date
DE 19510294 A	02-10-1996	NONE	
US 5527182 A	18-06-1996	WO 9625120 A AU 1923195 A	22-08-1996 04-09-1996
DE 4328490 A	02-03-1995	NONE	
DE 19629708 A	05-02-1998	NONE	