

Aug. 2, 1938.

J. G. WILLIAMS

2,125,703

EXHAUST MANIFOLD

Filed Feb. 19, 1937

Fig. 1.

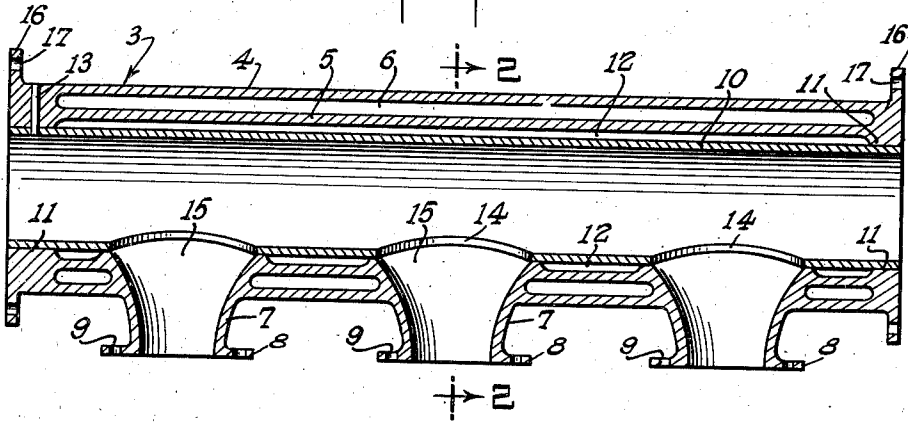
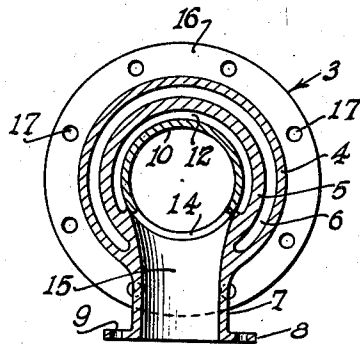

Fig. 2.



INVENTOR
John G. Williams.
BY
Raymond G. Muller
ATTORNEY

UNITED STATES PATENT OFFICE

2,125,703

EXHAUST MANIFOLD

John G. Williams, Franklin, Pa., assignor to Chicago Pneumatic Tool Company, New York, N. Y., a corporation of New Jersey

Application February 19, 1937, Serial No. 126,555

3 Claims. (Cl. 285—210)

This invention relates to exhaust manifolds for internal combustion engines.

Exhaust manifolds in Diesel and gas engines frequently break due to the difference in expansion between the inner and outer walls. Steel manifolds resist cracking fairly well but are objectionable because of their high manufacturing cost. Cast iron manifolds are relatively inexpensive but are liable to crack under the heat of the exhaust gases if they are made in long sections. The use of cast iron manifolds is frequently carried out by making the manifold in a series of comparatively short sections, which necessitates separate water connections for each section.

An object of the present invention is to obviate the use of short sections in cast iron manifolds by making provision for expansion. Other objects are to reduce the manufacturing cost and improve the appearance of a manifold of the type described.

A further object is the prevention of corrosion of the manifold shell due to condensation of exhaust gases. Steel manifolds especially are attacked by condensed exhaust gases so that in some instances they must be replaced. A feature of the present invention resides in a removable sleeve for protecting the shell.

Other objects of the invention will appear more clearly from the following description.

In the accompanying drawing, Fig. 1 is a longitudinal section of a manifold according to the present invention; and

Fig. 2 is a cross section, as indicated by the arrows 2—2 in Fig. 1.

The illustrative embodiment of the invention is designed with particular reference to Diesel engines, but is also applicable to internal combustion engines of other types. It comprises a shell 3, preferably of cast iron, said shell being of cylindrical shape and having an outer wall 4 and an inner wall 5 forming an annular chamber 6 therebetween. The chamber 6 may be supplied with water to protect the operator from burns. The shell has a plurality of radially extending neck portions 7 terminating in flanges 8. The flanges are perforated at 9 and thereby adapted to be bolted to the cylinder head of an engine (not shown) in the usual manner.

In order to protect the inner annular wall 5 of the shell 3 from the heat and corrosive effects of exhaust gases, I provide a steel sleeve 10, approximately co-extensive in length with the shell and fitting inwardly projecting flanges 11 at the ends of the shell. Between the flanges 11, the interior of wall 5 is recessed to form an an-

nular air chamber 12 surrounding sleeve 10. The sleeve is held in position with respect to the shell 3 by a steel pin 13. The sleeve 10 has a series of openings 14 registering with openings 15 extending from wall 5 to the ends of neck portions 7 for the admission of hot exhaust gases to the interior of the sleeve.

At the ends of shell 3, flanges 16, having bolt holes 17, provide means for attaching either end of the shell to a silencer or pipe extension (not shown) and for closing the other end.

The exhaust gases from the engine pass through openings 14 and 15 to the interior of the sleeve 10 thereby heating the sleeve and causing it to expand. Due to the fact that the sleeve is held at only one point, as by pin 13, it is free to expand and contract independently of the shell 3. The air space 12 surrounding the sleeve acts as a heat insulator for the shell 3. As a result, the temperature variations of the integral walls 4 and 5 are not sufficiently great to crack the shell.

The sleeve maintains the wall 5 out of contact with the exhaust gases and thereby prevents corrosion of the shell. When the sleeve becomes corroded it can be discarded and inexpensively replaced.

What is claimed is:

1. An exhaust manifold for internal combustion engines comprising an elongated shell, a sleeve in said shell, inwardly extending flanges on said shell for supporting the sleeve, the major portion of the sleeve being in spaced relation to the shell to provide a heat insulating chamber therebetween, said shell having a plurality of laterally extending inlet ports, said sleeve having ports registering with the shell ports to admit hot exhaust gases to the interior of the sleeve, the sleeve being arranged to close said heat insulating chamber from the inlet port.

2. An exhaust manifold for internal combustion engines comprising a shell having integral inner and outer walls defining a water chamber therebetween, a sleeve removably secured to the inner wall, said inner wall being recessed to provide an air chamber between the sleeve and said inner wall.

3. In an internal combustion engine, an exhaust manifold having three concentric walls, the outer and intermediate walls being integral and the inner wall being removable, said walls providing an annular air chamber surrounded by an annular water chamber, and a plurality of inlets for admitting exhaust gases to the interior of the removable wall.

JOHN G. WILLIAMS.