

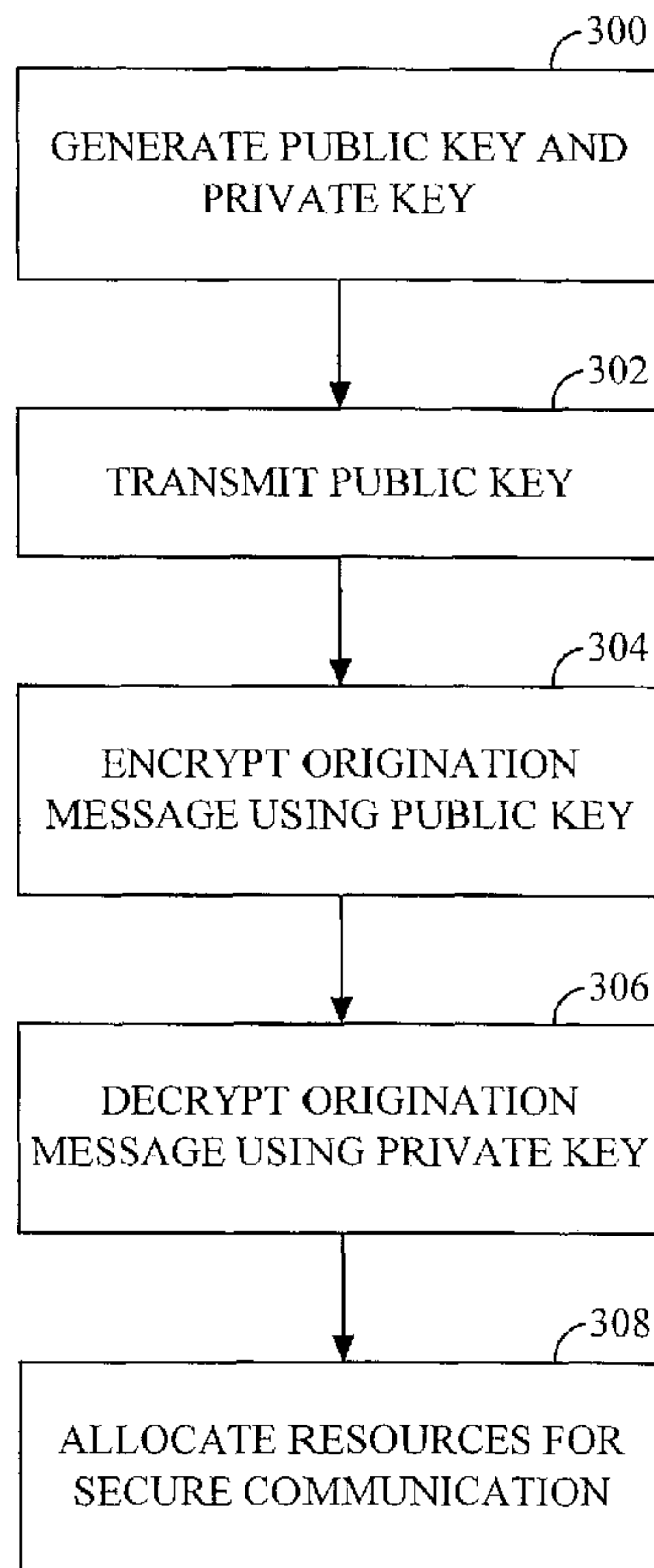

(86) Date de dépôt PCT/PCT Filing Date: 2002/10/11
 (87) Date publication PCT/PCT Publication Date: 2003/04/24
 (85) Entrée phase nationale/National Entry: 2004/04/15
 (86) N° demande PCT/PCT Application No.: US 2002/032564
 (87) N° publication PCT/PCT Publication No.: 2003/034774
 (30) Priorité/Priority: 2001/10/16 (09/981,449) US

(51) Cl.Int.⁷/Int.Cl.⁷ H04Q 7/38, H04L 29/06
 (71) Demandeur/Applicant:
QUALCOMM INCORPORATED, US
 (72) Inventeur/Inventor:
MAGGENTI, MARK, US
 (74) Agent: SMART & BIGGAR

(54) Titre : PROCÉDE ET DISPOSITIF PERMETTANT DE PROTÉGER L'IDENTITÉ ET LES CARACTÉRISTIQUES D'UN UTILISATEUR DANS UN SYSTÈME DE COMMUNICATION
 (54) Title: METHOD AND APPARATUS FOR PROVIDING PRIVACY OF USER IDENTITY AND CHARACTERISTICS IN A COMMUNICATION SYSTEM



(57) Abrégé/Abstract:

A method and apparatus for providing privacy of user identity and characteristics in a communication system. A public key and a private key is generated, corresponding to a transceiver. The public key is transmitted to a wireless communication device. The

(57) **Abrégé(suite)/Abstract(continued):**

wireless communication device encrypts one or more an initial messages using the public key and transmits the one or more encrypted initial messages to the transceiver. The transceiver receives the one or more encrypted initial messages and decrypts it using the private key. The transceiver may then allocate resources to initiate a desired communication between said wireless communication device and a second communication device.

(12) INTERNATIONAL APPLICATION PUBLISHED UNDER THE PATENT COOPERATION TREATY (PCT)

(19) World Intellectual Property Organization
International Bureau



(43) International Publication Date
24 April 2003 (24.04.2003)

PCT

(10) International Publication Number
WO 03/034774 A3

- (51) International Patent Classification⁷: **H04Q 7/38**, H04L 29/06
- (72) Inventor: **MAGGENTI, Mark**; 7254 Shoreline Drive, Apt. #137, San Diego, CA 92122 (US).
- (21) International Application Number: PCT/US02/32564
- (74) Agents: **WADSWORTH, Philip R.** et al.; 5775 Morehouse Drive, San Diego, CA 92121 (US).
- (22) International Filing Date: 11 October 2002 (11.10.2002)
- (81) Designated States (*national*): AE, AG, AL, AM, AT, AU, AZ, BA, BB, BG, BR, BY, BZ, CA, CH, CN, CO, CR, CU, CZ, DE, DK, DM, DZ, EC, EE, ES, FI, GB, GD, GE, GH, GM, HR, HU, ID, IL, IN, IS, JP, KE, KG, KP, KR, KZ, LC, LK, LR, LS, LT, LU, LV, MA, MD, MG, MK, MN, MW, MX, MZ, NO, NZ, OM, PH, PL, PT, RO, RU, SD, SE, SG, SI, SK, SL, TJ, TM, TN, TR, TT, TZ, UA, UG, UZ, VC, VN, YU, ZA, ZM, ZW.
- (25) Filing Language: English
- (26) Publication Language: English
- (30) Priority Data:
09/981,449 16 October 2001 (16.10.2001) US
- (71) Applicant: **QUALCOMM, INCORPORATED**
[US/US]; 5775 Morehouse Drive, San Diego, CA 92121 (US).
- (84) Designated States (*regional*): ARIPO patent (GH, GM, KE, LS, MW, MZ, SD, SL, SZ, TZ, UG, ZM, ZW), Eurasian patent (AM, AZ, BY, KG, KZ, MD, RU, TJ, TM), European patent (AT, BE, BG, CH, CY, CZ, DE, DK, EE,

[Continued on next page]

(54) Title: METHOD AND APPARATUS FOR PROVIDING PRIVACY OF USER IDENTITY AND CHARACTERISTICS IN A COMMUNICATION SYSTEM

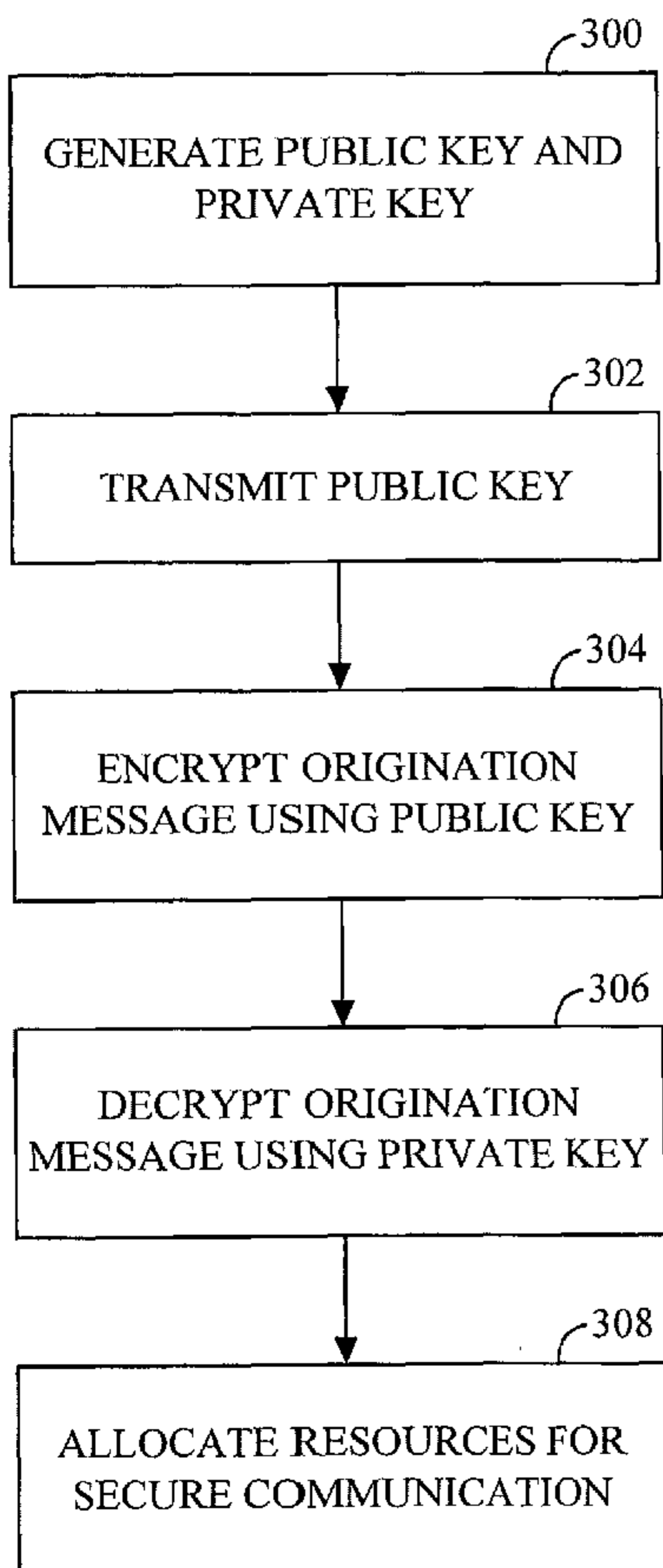

(57) Abstract: A method and apparatus for providing privacy of user identity and characteristics in a communication system. A public key and a private key is generated, corresponding to a transceiver. The public key is transmitted to a wireless communication device. The wireless communication device encrypts one or more initial messages using the public key and transmits the one or more encrypted initial messages to the transceiver. The transceiver receives the one or more encrypted initial messages and decrypts it using the private key. The transceiver may then allocate resources to initiate a desired communication between said wireless communication device and a second communication device.

WO 03/034774 A3

WO 03/034774 A3



ES, FI, FR, GB, GR, IE, IT, LU, MC, NL, PT, SE, SK, TR), OAPI patent (BF, BJ, CF, CG, CI, CM, GA, GN, GQ, GW, ML, MR, NE, SN, TD, TG).

(88) Date of publication of the international search report:
10 July 2003

Published:

- *with international search report*
- *before the expiration of the time limit for amending the claims and to be republished in the event of receipt of amendments*

For two-letter codes and other abbreviations, refer to the "Guidance Notes on Codes and Abbreviations" appearing at the beginning of each regular issue of the PCT Gazette.

METHOD AND APPARATUS FOR PROVIDING PRIVACY OF USER IDENTITY AND CHARACTERISTICS IN A COMMUNICATION SYSTEM

BACKGROUND OF THE INVENTION

I. Field of the Invention

[0001] The present invention relates generally to communication systems. More particularly, this invention relates to a system and method for providing privacy of user identity and characteristics in a communication system.

II. Description of the Related Art

[0002] Recently, there has become a need in the telecommunications industry to provide secure communications in both wireless and wireline communication systems. With the advent of wireless telephony, the ability to provide secure communications have become even more important, due to the ubiquitous nature of electromagnetic signals.

[0003] In prior art communication systems, a first wireless communication device, such as a cellular telephone, may initiate communications with a second wireless communication device. Communications between the two wireless communication devices are generally accomplished using a fixed transceiver, commonly referred to as a base station. When the first wireless communication device initiates communications with the second wireless communication device, it does so by transmitting one or more initial message(s), for example, an origination message, to the fixed transceiver. The initial message(s) typically contains various information, such as an identification of the first wireless communication device (a mobile identification number (MIN), an electronic serial number (ESN), an international mobile subscriber identification (IMSI) number, etc), position-related information of the wireless communication device, an identification of the second wireless communication device, the type of communications desired (for example, secure voice, secure data, clear voice, clear data), and so on.

[0004] In many instances, it may not be desirable to allow the information contained in the initial message(s) to be received by an unauthorized recipient. For example, it may be desirable to keep a user's identity secret during all portions of a wireless communication, including the transmission of one or more initial messages.

- [0005] One method for protecting a user's identity during transmission of an initial message(s) involves the use of a temporary user identification code, sometimes referred to as a Temporary Mobile Subscriber Identity, or (TMSI), to protect a device's identification code, such as an IMSI. In this case, a user transmits one or more initial messages, including the IMSI, and is then provided a TMSI for use during subsequent communications. The TMSI is usually transmitted over an encrypted channel to the requesting communication device, so that an unauthorized recipient cannot intercept it. The TMSI is then used in subsequent communications to identify the communication device. .
- [0006] The disadvantage of the security method described above, of course, is that the first wireless communication device must at least one time send the IMSI, or other identifier, over the air for anyone to intercept. This means that the identifier and/or a number of informational items, such as a wireless communication device identification number, position-related information, etc., may be compromised, thus jeopardizing the security or anonymity of the first and/or possibly second wireless communication devices.
- [0007] That is needed is a method and apparatus for initiating secure communications by a wireless communication device without compromising a user's identity and other characteristics normally transmitted during a request to initiate communications, while still allowing the fixed transceiver to determine the identity and other characteristics.

SUMMARY

- [0008] The present invention is directed to a method and apparatus for providing privacy of user identity and characteristics in a communication system. In one embodiment, the present invention is directed to an apparatus, the apparatus comprising a processor for generating a public key and a private key associated with a transceiver. The public key is transmitted to a communication device. The communication device encrypts one or more initial messages using the public key when the it is desired to maintain secrecy of the apparatus' identification code or other characteristics. The encrypted initial message(s) is transmitted by the communication device to the transceiver, where it is decrypted using the private key. A processor then allocates resources for establishing the requested service devicefor the communication device.

BRIEF DESCRIPTION OF THE DRAWINGS

[0009] The features, objects, and advantages of the present invention will become more apparent from the detailed description set forth below when taken in conjunction with the drawings in which like reference characters identify correspondingly throughout and wherein:

FIG. 1 illustrates a wireless terrestrial communication system in which various embodiments of the present invention are incorporated;

FIG. 2 illustrates a functional block diagram of a wireless communication device as used in one embodiment of the present invention; and

FIG. 3 is a flow diagram illustrating the method for providing privacy of user identity and characteristics in a secure communication system.

DETAILED DESCRIPTION

[0010] The present invention is directed to a method and apparatus for providing privacy of user identity and characteristics in a communication system. Although the method and apparatus is described herein with respect to a wireless terrestrial telephone system, it should be understood that the method and apparatus for providing privacy of user identity and characteristics could be applied to a number of other situations. For example, the method and apparatus could alternatively be used in a satellite communication system, or in a wireline communication system, such as a Public Switched Telephone Network (PSTN). In addition, the method and apparatus could be used in other types of electronic devices other than telephones, such as facsimile machines, Personal Digital Assistants (PDAs), wireless data modems, etc.

[0011] FIG. 1 illustrates a wireless terrestrial communication system 100 in which various embodiments of the present invention are incorporated. Wireless communication devices (WCDs) 102 and 104 communicate with fixed transceivers, otherwise known as basestation transceivers (BTSs) 106, 108, and/or 110, or simply transceivers, wirelessly using one or more well-known air-interfaces, such as code division multiple access (CDMA), time division multiple access (TDMA), global system for mobile communications (GSM), or others. The term "transceiver" used herein refers to any fixed or mobile transceiver, such as a satellite, mobile base station, or transceiver mounted in a moving vehicle. WCDs 102 and 104 are shown in FIG. 1 comprising cellular telephones, although it should be understood that WCDs 102 and 104 could alternatively comprises a variety of electronic devices, as noted above.

[0012] Communications to and from WCDs may be routed to devices outside communication system 100 (such as telephones or data modems) by way of mobile switching center (MSC) 114. MSC 114 routes communications to these other devices either through public switched telephone network (PSTN) 116 or through data network 118. Satellite gateway 120 is used to connect satellite devices, such as telephones or data modems, generally to PSTN 116. The information is subsequently received by data device 122 or modem 124, as the case may be. Data modem 128 is connected to PSTN 116 to enable computers, digital telephones, and other data devices, to communicate over PSTN 116.

[0013] The various communication devices comprising communication system 100, such as WCDs, data devices, and modems, may be capable of transmitting and receiving "secure" voice and/or data. In general, this means that communication signals transmitted from WCDs 102 and 104 are encoded, or encrypted, using one or more well-known techniques. Communication signals received from BTS 106, for example, arrive at WCD 102 in encrypted form, and are decrypted using similar well-known techniques.

[0014] One method of performing secure communications is known as public-key cryptography. Public-key cryptography is based on the concept of a key pair. Each half of the pair (one key) can encrypt information so that only the other half (the other key) can decrypt it. One part of the key pair, the private key, is known only by the designated owner; the other part, the public key, is published widely but is still associated with the owner. Key pairs have a unique feature -- data encrypted with one key can be decrypted with the other key in the pair. In other words, it makes no difference if you use the private key or public key to encrypt a message, the recipient can use the other key to decrypt it. These keys can be used in different ways to provide message confidentiality and to prove the authenticity of a message's originator. In the first case, one would use the recipient's public key to encrypt a message; in the other, one would use a private key to encrypt a message.

[0015] In one embodiment, communication system 100 uses public-key cryptography to provide secure communications between WCDs and other communication devices in communication system 100. Of course, other known encryption systems could be used in the alternative to public-key cryptography. In this embodiment, a public key and a corresponding private key are generated at one or more predetermined times and stored in a database. The generation of the key pair can take place at any BTS, at MSC 114, at a data device connected to data network 118, satellite gateway 120, or PSTN 116. Once generated, the keys can be stored in a database located at any of the aforementioned entities. In another embodiment, key generation, storage, and

management could be done at a secure server, shown in FIG. 1 as security manager 126. Although FIG. 1 depicts security manager 126 as being located proximate to BTS 106, it should be understood that it could alternatively be located within BTS 106, or in any one of the aforementioned entities such as MSC 114 or BSC 112.

[0016] Keys may be generated at any time, and are frequently generated at predetermined time intervals, for example once every hour. Periodic key generation minimizes the problem of a potential security breach, such as an unauthorized person discovering a private key. Keys could be generated upon request from a user of a WCD or other data device in communication system 100. Multiple key pairs could be generated, each key pair assigned to a unique BTS for use with WCDs within the respective coverage area of each BTS.

[0017] At some point in time after a key pair has been generated, a public key is transmitted to WCDs throughout communication system 100. The transmission may be accomplished at predetermined times (for example, upon expiration of a timer), upon a request from data device within communication system 100, or by both methods. In one embodiment, the public key is transmitted to only a subset of data devices in communication system 100, for example, only to WCDs in the region of BTS 108, only WCDs in a certain base station sector, WCDs in one or more cities, etc. In another embodiment, the public key is transmitted to all communication devices throughout communication system 100.

[0018] In one embodiment, the public key transmitted from a BTS is transmitted on a paging channel found in many wireless communication systems. Generally, any WCD that is registered with communication system 100 will receive such a transmission. The public key may alternatively be transmitted using other known techniques, such as using the well-known Short Message Service, or SMS. After reception by a WCD, the public key is stored in an electronic memory contained within the WCD for use in encrypting subsequent transmissions from the WCD.

[0019] The public key may be digitally "signed" by a "trusted entity" using techniques well-known in the art to prevent "spoofing" the public key prior to transmission by a BTS. The trusted entity may be security manager 126, a service provider in charge of communication system 100, or any entity within communication system 100 tasked with generating the public key. The trusted entity is usually certified by an independent agency, such as Verisign of Mountain View, California. After certification, the trusted entity then digitally signs the public key using an authentication certificate given to it by the independent agency. Each WCD then

authenticates the signed public key before use storing the key, again, using methods well known in the art.

[0020] In one embodiment, when a WCD desires to initiate a communication, it uses the stored public key to encrypt one or more initial communication messages, commonly known as an origination message, to a BTS. An origination message is a term that is used in the telecommunication industry to describe a request for initiating a communication. The initial message(s) may comprise a single message (such as an origination message), or the initial message(s) may comprise a series of messages, any one of which may contain identification and/or other characteristics of the WCD, such as position-related information pertaining to the location of the WCD, an identification of a target communication device, the type of communications desired (for example, secure voice, secure data, clear voice, clear data), and so on. WCD identification is presently accomplished by sending a numeric or alpha-numeric sequence which uniquely identifies the WCD within communication system 100. Typically, this identification comprises a mobile identification number (MIN), electronic serial number (ESN), international mobile subscriber identification (IMSI) number, or other unique identifier. The identification sequence is typically stored in a non-volatile memory within the WCD.

[0021] The initial message(s) may request one of a number of services available to the communication device. For example, the available services may include secure voice, secure data, clear voice, clear date, and so on. Various sub-categories of these services may also exist, such as packet data communications vs. asynchronous data communications. One such service may be used, for example, to transmit non-secure position-related information at regular intervals to another WCD or to some entity in communication system 100, but to keep the WCD's identification anonymous. Or, in another embodiment, a non-secure voice communication could be established without compromising the originator's identity.

[0022] In another embodiment, the initial message(s) comprises the entire information to be transmitted. For example, it may be desirable to transmit a WCD's identity and position-related information all in the initial communication. Such a short communication could be accomplished using SMS or by using a signaling channel, such as a access channel. In this embodiment, resources do not have to be allocated by a BTS or by a MSC/BSC in response to the initial message(s).

[0023] In any case, the WCD encrypts the initial message using the stored public key prior to transmitting the initial message(s) to a BTS. This may involve encrypting only portions of the

initial message(s), or it may involve encrypting all information contained within the initial message(s).

[0024] The encrypted initial message(s) is transmitted to one or more BTSs, where it is received and processed, either by the BTS or by another entity, such as MSC 114, or security manager 126. Processing comprises decrypting the initial message(s) using a private key corresponding to the public key that was used by the WCD to encrypt the initial message(s). Once the initial message(s) has been decrypted, resources may then be allocated to accommodate the requested communication service, such as secure voice, secure data, clear voice, or clear data. This generally comprises allocating communication equipment resources, such as a modulator/demodulator pair within one or more BTSs and/or allocating a switching circuit within MSC 114 to establish a communication link to a communication device through PSTN 116 or data network 118. In addition, a communication link is established with a target communication device as specified by the WCD initiating the communication. The target communication device can be any entity within communication system 100 and may be specified by the WCD in the initial message(s) or in a subsequent communication between the WCD and a BTS. A new key may be issued by security manager 126 and transmitted to the WCD and/or target communication device for subsequent communications.

[0025] FIG. 2 illustrates a functional block diagram of WCD 102 or WCD 104 as used in one embodiment of the present invention. Again, it should be understood that the components shown in FIG. 2 are not restricted to use in wireless communication devices but could be implemented in other devices, such as a landline telephone, laptop or desktop computer, etc. In this embodiment, WCD 102 is a wireless telephone capable of secure communications.

[0026] In any case, after a BTS has transmitted the public key, either signed or unsigned, it is received and downconverted using RF circuitry 200 using techniques suited for the applicable type of wireless communications, using techniques well-known in the art. RF circuitry comprises a transmitter and a receiver. The encrypted public key is identified by processor 202 and, if necessary, passed to decryption processor 206 for authentication if the public key was digitally signed. Then, the public key is stored in an electronic memory, shown as memory 204. Memory 204 comprises one of any number of known electronic storage devices, such as a random access memory (RAM), flash memory, EEPROM, etc.

[0027] When a user of WCD 102 desires to initiate a communication while keeping the WCD's identity and/or other characteristics private, the user initiates an action, such as pressing a sequence of keys on WCD 102, to begin establishing a communication link. In response to the

user action, processor 202 generates one or more initial message(s) for transmission to a BTS. The initial message(s) informs communication system 100 of at least the identity of the requesting WCD (in this case WCD 102), and may additionally provide other information pertinent, such as the type of communication service desired, or position-related information pertaining to the location of the WCD. Position-related information may comprise latitude and longitude coordinates (or other coordinates), timing, or other measurements which would enable one to locate the WCD. The position-related information could alternatively, or in addition, comprise a landmark which is proximate to the WCD, such as the name of a city, building, river, bridge, street address, and so on. The identity of the WCD may comprise a mobile identification number (MIN), an electronic serial number (ESN), an International mobile subscriber identification (IMSI) number, or other numeric or alpha-numeric sequence for uniquely identifying a WCD within communication system 100. Either all or a portion of the information contained in the initial message(s) is encrypted using the public key stored in memory 204 in conjunction with encryption processor 208. Encryption processor 208 comprises electronic circuitry or a combination of hardware and software, for encrypting this information using the public key.

[0028] Once the initial message(s) is encrypted, it is modulated and upconverted using RF circuitry 200 and transmitted to a BTS. The encrypted initial message(s) is received by a BTS and is generally forwarded to an entity for decryption, such as BSC 112, MSC 114, or security manager 126. The entity decrypts the initial message(s) using a private key corresponding to the public key that was previously transmitted to WCDs and other communication devices within communication system 100. After the initial message(s) has been decrypted, resources may be allocated to establish the desired communication service, as previously described.

[0029] FIG. 3 is a flow diagram illustrating the method for providing privacy of user identity and characteristics in a communication system. In step 300, an entity within communication system 100 generates a key pair, namely a public key and a private key. At least the private key is stored in a secured memory, generally within the entity that generated it. The public key is then distributed to all or a subset of communication devices within communication system 100, shown as step 302. In one embodiment, the public key is digitally signed to ensure the authenticity of the source of the public key.

[0030] The public key is received by one or more communication devices within communication system 100 and stored in an electronic memory. When a communication is desired by a user of, for example, a wireless communication device, some or all information pertaining to one or more

initial messages, such as an identification of the transmitting WCD, is encrypted using the public key stored in the memory of the wireless communication device, shown in FIG. 3 as step 304. The encrypted initial message(s) is then transmitted to a BTS.

[0031] The encrypted initial message(s) is then decrypted using the private key corresponding to the public key that was distributed to the communication devices of communication system 100. Once the initial message(s) has been decrypted, resources may be allocated to initiate and support a the desired communication servicesecure .

[0032] The previous description of the preferred embodiments is provided to enable any person skilled in the art to make or use the present invention. The various modifications to these embodiments will be readily apparent to those skilled in the art, and the generic principles defined herein may be applied to other embodiments without the use of the inventive faculty. Thus, the present invention is not intended to be limited to the embodiments shown herein but is to be accorded the widest scope consistent with the principles and novel features disclosed herein.

WHAT IS CLAIMED IS:

CLAIMS

- [c1] 1. A method for providing privacy of user identity and characteristics in a communication system, comprising the steps of:
transmitting a public key from a transceiver to a communication device;
receiving one or more initial messages from said wireless communication device, wherein at least a portion of said one or more initial messages are encrypted using said public key; and
decrypting said encrypted portion of said one or more initial messages using a private key corresponding to said public key.
- [c2] 2. The method of claim 1 wherein said encrypted portion of said initial message comprises an identification of said communication device.
- [c3] 3. The method of claim 1 further comprising the step of:
allocating resources to initiate a communication between said wireless communication device and a second communication device.
- [c4] 4. The method of claim 3, wherein said communication comprises a secure communication.
- [c5] 5. The method of claim 1 further comprising the step of signing said public key for authentication purposes prior to the step of transmitting said public key.
- [c6] 6. The method of claim 1 wherein said public key is transmitted at a predetermined event.
- [c7] 7. The method of claim 6 wherein said predetermined event comprises an expiration of a timer.
- [c8] 8. Apparatus for providing privacy of user identity and characteristics in a communication system, comprising:
a processor for generating a public key and a private key associated with a transceiver;

a transmitter, coupled to said processor, for transmitting said public key to a communication device;

a receiver, coupled to said processor, for receiving one or more initial messages from said wireless communication device, wherein at least a portion of said one or more initial messages is encrypted using said public key; and

a decryption processor for decrypting said portion of said one or more initial messages using said private key.

[c9] 9. The apparatus of claim 8, wherein said portion of said initial message comprises an identification of said communication device.

[c10] 10. The apparatus of claim 8 wherein said processor is further for allocating resources to initiate communication between said wireless communication device and a second communication device.

[c11] 11. The apparatus of claim 8 further comprising an encryption processor for signing said public key for authentication purposes prior to transmitting said public key to said communication device.

[c12] 12. A method for providing privacy of user identity and characteristics in a communication system, comprising the steps of:

receiving a public key from a transceiver; and

transmitting one or more initial messages to said transceiver, wherein at least a portion of said one or more initial messages is encrypted using said public key.

[c13] 13. The method of claim 12, wherein said portion of said initial message comprises an identification of said communication device.

[c14] 14. The method of claim 12 further comprising the step of:

performing an authentication procedure on said public key to determine if said public key was transmitted by a trusted entity.

[c15] 15. An apparatus for providing privacy of user identity and characteristics in a

communication system, comprising:

a receiver for receiving a public key from a transceiver;

a processor for encrypting at least a portion of one or more an initial messages with said public key; and

a transmitter for transmitting said one or more initial messages to said transceiver.

[c16] 16. The apparatus of claim 15 wherein said public key is signed and said processor is further for decrypting said public key and performing an authentication procedure on said public key to determine if said public key was transmitted by said transceiver.

[c17] 17. The apparatus of claim 15 wherein said portion of said one or more initial messages comprises an identification of said communication device.

[c18] 18. A system for providing privacy of user identity and characteristics in a communication system, comprising:

a transceiver, comprising:

a processor for generating a public key and a private key associated with a transceiver;

a transmitter, coupled to said processor, for transmitting said public key to a communication device;

a receiver, coupled to said processor, for receiving one or more an initial messages from said wireless communication device, wherein at least a portion of said one or more initial message s is encrypted using said public key;

a decryption processor for decrypting said portion of said one or more initial messages using said private key;

said communication device comprising:

a second receiver for receiving said public key from said transceiver;

a second processor for encrypting at least a portion of said one or more initial messages with said public key; and

a second transmitter for transmitting said one or more encrypted initial messages to said transceiver.

[c19] 19. The system of claim 18, wherein said portion of said one or more initial messages

comprises an identification of said communication device.

[c20] 20. A method for providing privacy of user identity and characteristics in a communication system, comprising the steps of:

generating a public key and a private key corresponding to a transceiver;
transmitting said public key to a communication device;
encrypting at least a portion of one or more an initial messages using said public key;
transmitting said one or more initial messages from said communication device to said transceiver; and
decrypting at least said portion of said one or more initial messages using said private key.

[c21] 21. The method of claim 20, further comprising the step of allocating resources to initiate a communication between said wireless communication device and a second communication device.

[c22] 22. The method of claim 21, wherein said communication comprises a secure communication.

[c23] 23. The method of claim 20, wherein said portion of said one or more initial messages comprises an identification of said communication device.

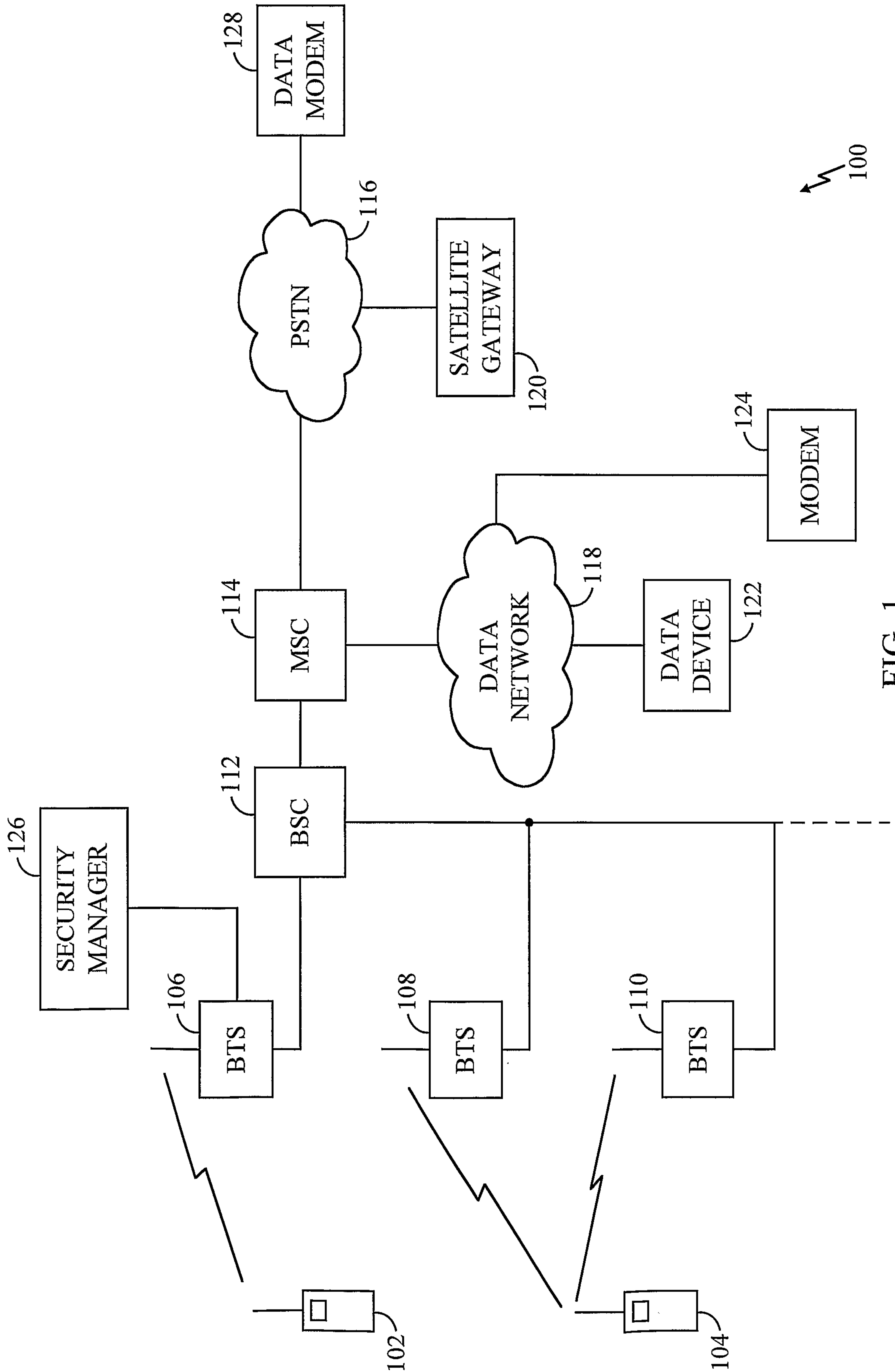
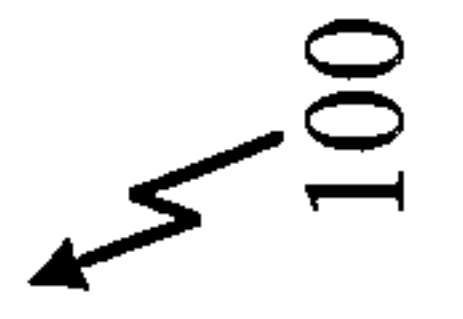

FIG. 1



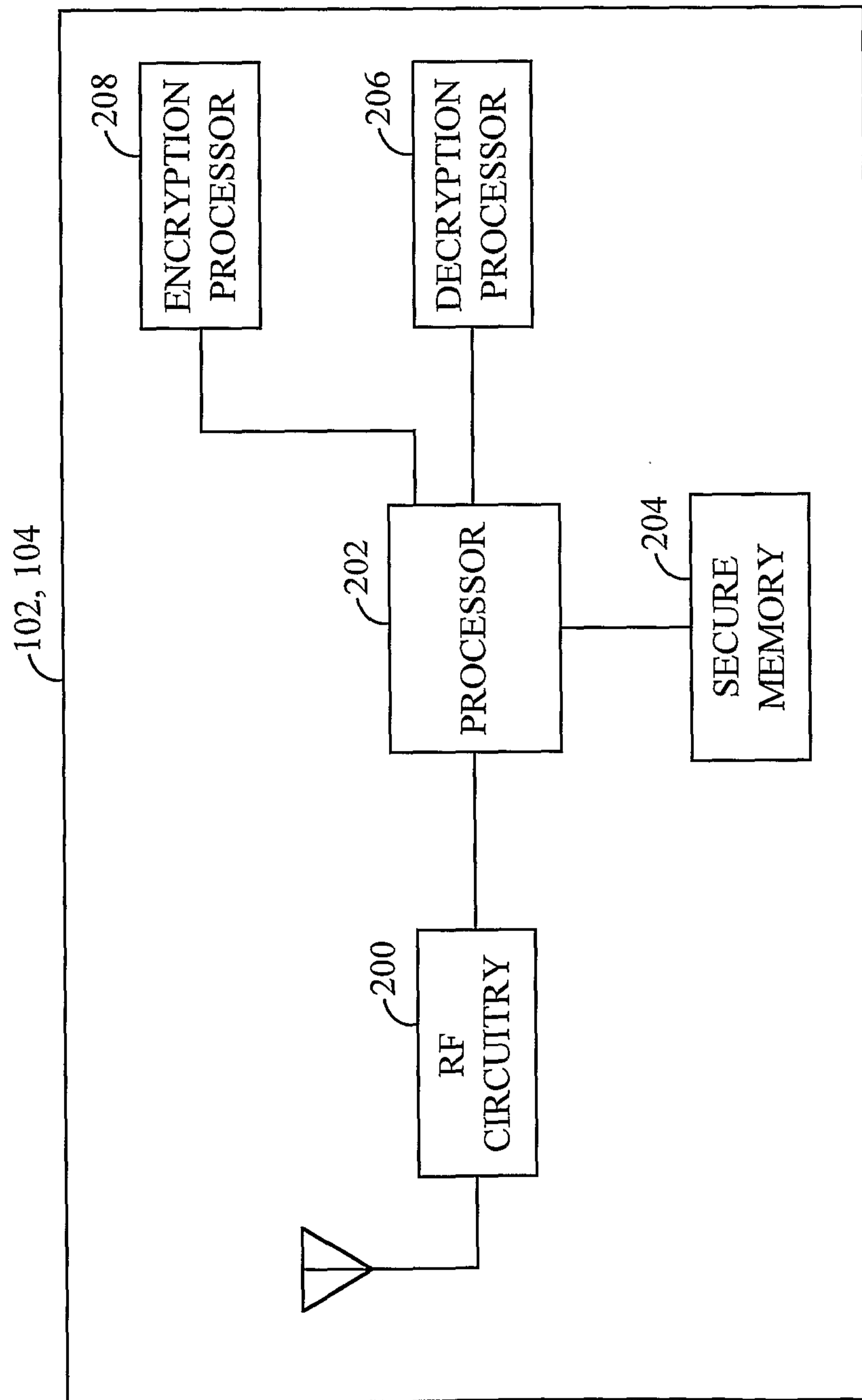

FIG. 2

3/3

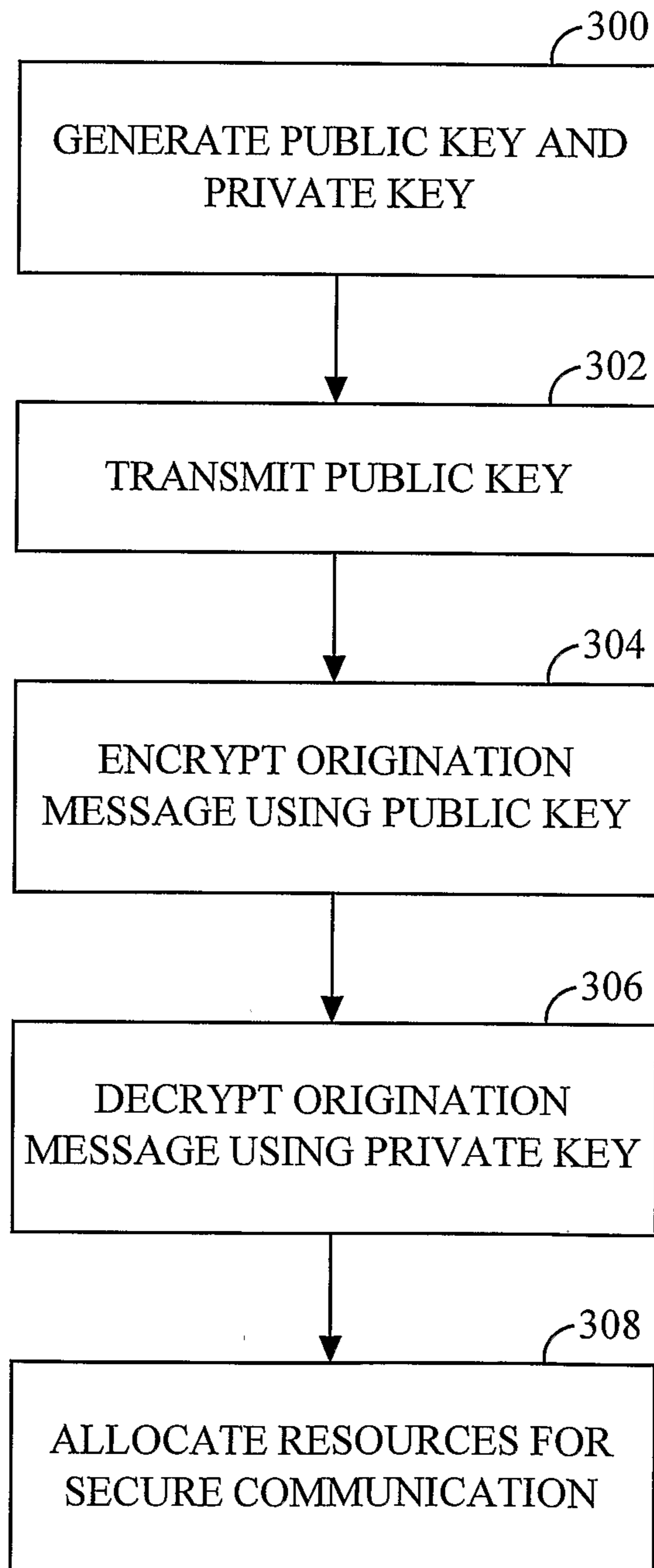

FIG. 3

300
GENERATE PUBLIC KEY AND
PRIVATE KEY

302
TRANSMIT PUBLIC KEY

304
ENCRYPT ORIGINATION
MESSAGE USING PUBLIC KEY

306
DECRYPT ORIGINATION
MESSAGE USING PRIVATE KEY

308
ALLOCATE RESOURCES FOR
SECURE COMMUNICATION