

F. W. WAKEFIELD.
BODY FOR LIGHTING FIXTURES.

APPLICATION FILED JAN. 3, 1905.

2 SHEETS—SHEET 1.

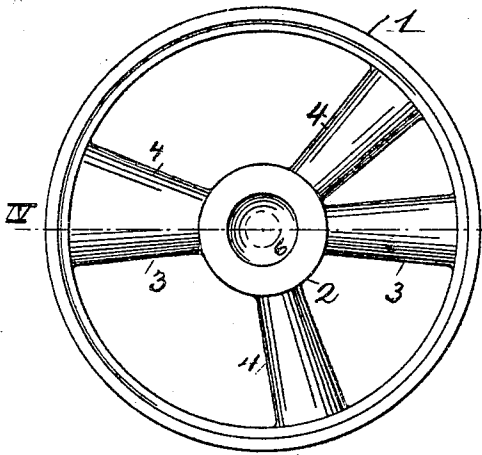

Fig. I.

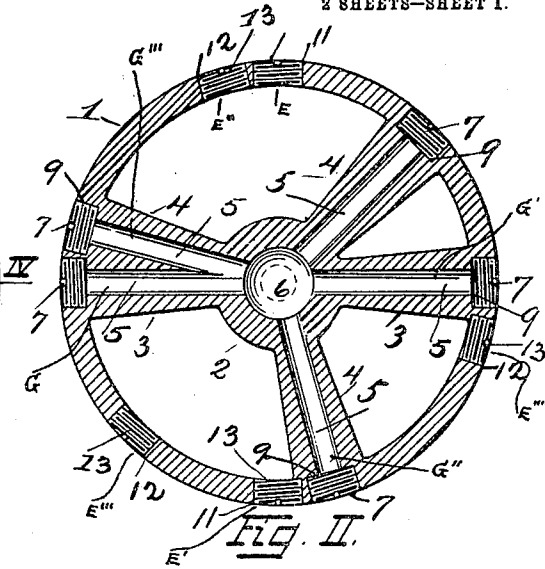

Fig. II.

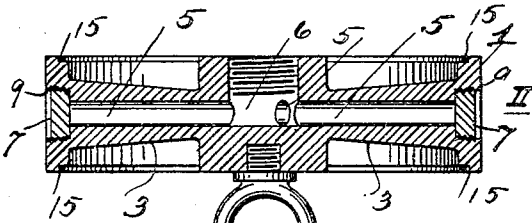

Fig. IV.

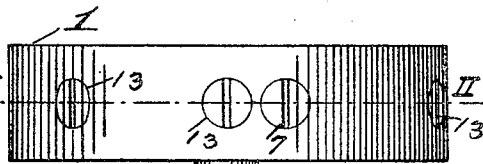

Fig. III.

Witnesses:

F. C. Valentine
C. H. Olds

Inventor,
Fredrick W. Wakefield.
by Wm. W. Monroe
Attorney.

F. W. WAKEFIELD.
BODY FOR LIGHTING FIXTURES.

APPLICATION FILED JAN. 3, 1905.

2 SHEETS—SHEET 2.

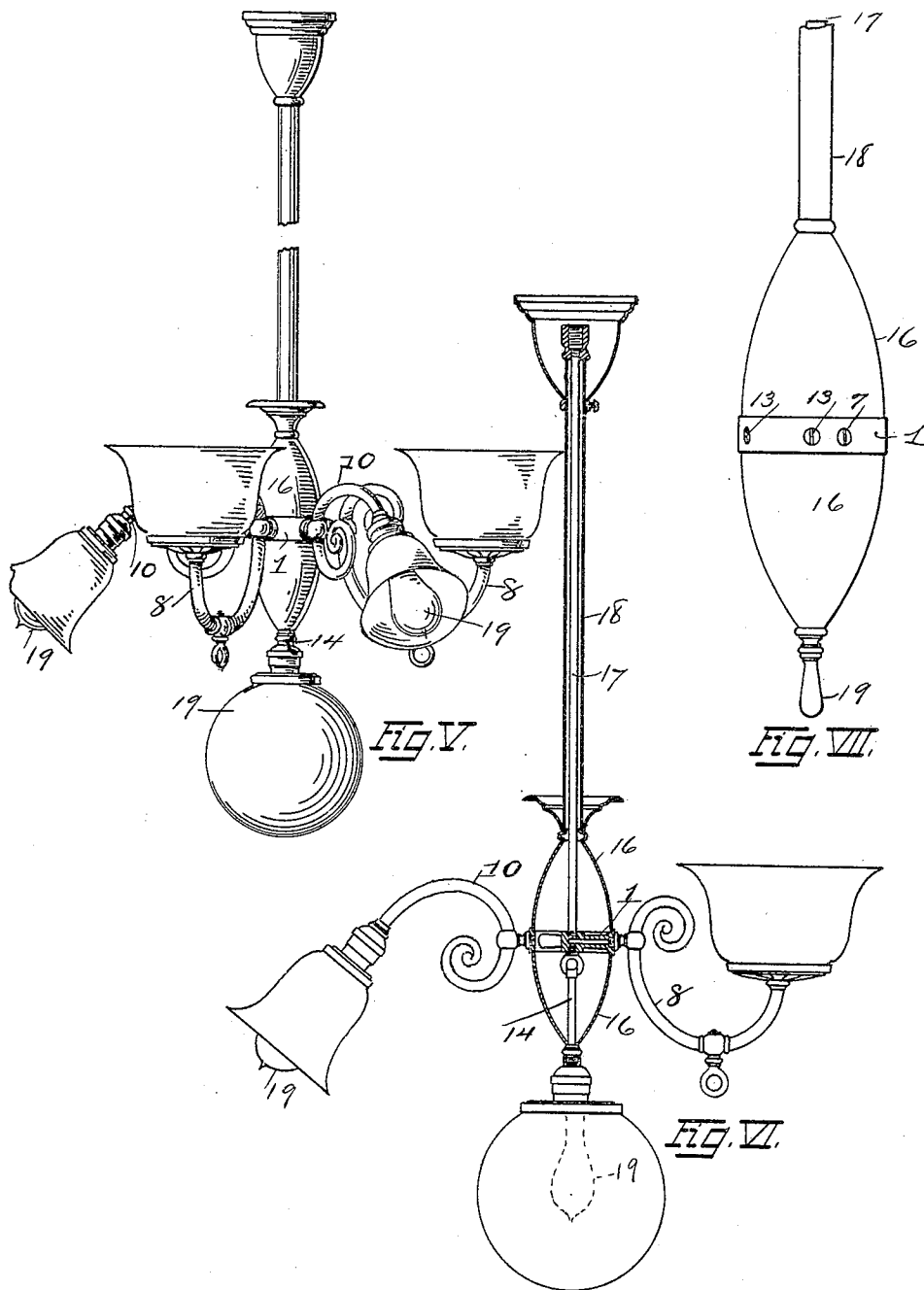

Witnesses:
F. C. Valentine
C. H. Olds

Inventor,
Frederick W. Wakefield
by W. H. Moore
Attorney

UNITED STATES PATENT OFFICE.

FREDERICK W. WAKEFIELD, OF CLEVELAND, OHIO.

BODY FOR LIGHTING-FIXTURES.

No. 800,960.

Specification of Letters Patent.

Patented Oct. 3, 1905.

Application filed January 3, 1905. Serial No. 239,330.

To all whom it may concern:

Be it known that I, FREDERICK W. WAKEFIELD, a citizen of the United States, and a resident of Cleveland, county of Cuyahoga, State of Ohio, have invented certain new and useful Improvements in Bodies for Lighting-Fixtures, of which I hereby declare the following to be a full, clear, and exact description; such as will enable others skilled in the art to which it appertains to make and use the same.

The objects of the invention are to provide a finished metal part for lighting-fixtures which will serve as a permanent center or body to which any desired number of arms or branches may be attached for either electric or gas lighting or for both uses combined in one fixture.

The primary object, however, is found in the peculiar adaptability of this body portion for use with a varying number of arms, so that a fixture with a definite number of arms can be enlarged by the addition of a greater number of arms or made smaller in size by reducing the number of arms.

The invention consists in the novel features of construction of the body and the combination and arrangement of parts, as hereinafter described, shown in the accompanying drawings, and specifically pointed out in the claims.

In the accompanying drawings, Figure 1 is a plan view of the improved form of body. Fig. 2 is a transverse section on a central horizontal plane on line 2 2, Fig. 3. Fig. 3 is an edge view thereof, showing a central pendant for finish or the attachment of an electric light. Fig. 4 is a vertical central section thereof on line 4 4, Fig. 1. Fig. 5 is an elevation of a complete fixture provided with three arms for gas-lighting and three for electric lighting. Fig. 6 is a vertical central section thereof, and Fig. 7 is an enlarged elevation of central portion before the arms are attached.

In the drawings, 1 is the body, which is disk-shaped and comprises a metal ring, a central hub 2, and radial spokes or arms 3 and 4, which are perforated at 5, the passages thus formed leading to a central opening 6 in the hub. These passages are for gas when the fixture is used for gas-lighting. It will be seen that the spokes are so spaced that one pair of them, 3, can be used when two oppositely-placed arms are employed, and a group of three, as at 4, can be used when three arms are employed.

The passages not employed at any one time are closed by plugs 7, so that the gas will not escape therefrom, and the arms 8, which support the gas-burners, are secured in the threaded extremities 9 of the gas-passages.

It will be seen that the body 1 is open above and below, and hence there is plenty of room for the insertion of wires for electric lighting. The arms 10 for this purpose are then attached to the threaded openings 11 or 12, intermediately spaced between the spokes and so arranged as to coincide with the spacing of the spokes. For instance, if the oppositely-placed spokes 3 are employed for gas-lighting the oppositely-placed openings 11 are used for the attachment of the arms 10 for electric lighting. This will give an evenly-balanced effect to the fixture. When, however, spokes 4 are employed for gas-lighting, the openings 12 are used for the insertion of the arms 10 for electric lighting, and all the other openings are closed by the plugs 7 and 13, so as to give a smooth and finished appearance to the exterior of the body.

It will be seen that the fixture illustrated is capable of many combination uses with gas and electric arms. For instance, it can be used as a two or three light gas-fixture.

By employing a central pendant 14, secured to the disk, it can be used as a two, three, or four light electric fixture. This pendant comprises a ring 20, screwed into the lower surface of the hub, and a tube 14, inserted in the ring. An ornamental cap 22 covers the lower end of the tube when it is not in use. The function of this pendant is to support an incandescent bulb at its lower end, the wires leading to which are inclosed in the tube. This is clearly seen in Figs. 3 and 4 as a two gas $G\ G'$ in one line and one electric fixture 19, as a two gas $G\ G'$ in line and two electric $E\ E'$ at right angles thereto fixtures, as a two gas $G\ G'$ and three electric fixtures $E\ E'$ and 19, as a three gas $G''\ G''' G''''$ and three electric fixtures $E''\ E''' E''''$, as a three gas $G''\ G''' G''''$ and four electric fixtures $E''\ E''' E''''$ 19.

In Fig. 4 is seen a narrow annular shoulder 15 upon each edge of the body, into which the edges of an inclosing case 16 can be set, thus completing the body. 17 is the pendent gas-pipe, and 18 the sheath in which the wires are carried which supply current to the lamps 19.

The number of arms in a body intended only for gas-lighting need only be limited by the diameter of the body and the space required

to attach the arms. The same would be true where electric lights only were employed and the arms were spaced for that purpose only. By changing the style and design of the arms an endless field of usefulness is possible.

The advantages of such a body are obvious, since with this body the dealer can supply the consumer on demand with a finished fixture in any of the above number of gas or electric lights or combination thereof without being compelled to carry a large stock of gas and electric fixtures.

Having described my invention, what I claim as new, and desire to secure by Letters Patent, is—

1. A body for a gas-fixture, comprising, in combination, a ring portion, provided with an annular shoulder on each edge, a central hub provided with a central gas-opening, spokes connecting said hub and ring, and provided with radial gas-passages, the said spokes being so arranged as to form groups of spaced passages for gas and plugs in the ring for the unused groups of passages and gas-lighting arms upon the ring connecting with the used group, substantially as described.

2. In a body for a combined gas or electric light fixture, the combination with a metal ring and hub, of spokes, connecting the hub and ring, and arranged in groups the spokes in each group being regularly spaced about the ring, gas-passages in said spokes and hub, plugs for the unused passages, groups of openings in the ring for electric lighting, intermediate between the said spokes, the said openings in each group of openings being regularly spaced about said ring, substantially as described.

3. A body for combined gas and electric lighting, comprising, in combination, a ring portion provided with an annular shoulder

upon each edge, a central hub provided with a gas-passage, spokes connecting the ring and hub, the said spokes being provided with radial passages communicating with said passage in the hub, and the said spokes and passages, being spaced in balanced groups, threaded extremities for said passages, for the insertion of burner-arms—the said ring being also provided with threaded openings for the insertion of arms for electric lighting, the said openings for arms and electric lighting being also spaced in balanced groups, between the aforesaid spokes, substantially as described.

4. A body for a lighting-fixture comprising a metal ring, a hub therefor, by means of which said ring is suspended, radial arms connecting said hub and ring—the said ring being provided with threaded openings for the attachment of burner-tubes, and the said openings being arranged in balanced and spaced groups, each group of openings differing numerically from every other group.

5. A body for a lighting-fixture, comprising a metal ring, having an annular shoulder on each edge, a central hollow pendant secured to the lower side of the hub, radial spokes connecting said hub and ring, a central side of the hub, the said ring being provided with threaded openings for the insertion of burner-tubes, and the said openings spaced in balanced groups each group being numerically different from the other groups—substantially as described.

In testimony whereof I hereunto set my hand.

FREDERICK W. WAKEFIELD.

In presence of—

WM. M. MONROE,
C. H. OLDS.