

(19) World Intellectual Property Organization
International Bureau



(43) International Publication Date
10 March 2011 (10.03.2011)

(10) International Publication Number
WO 2011/027245 A1

(51) International Patent Classification:
A47C 4/02 (2006.01)

(21) International Application Number:
PCT/IB2010/053571

(22) International Filing Date:
6 August 2010 (06.08.2010)

(25) Filing Language: Italian

(26) Publication Language: English

(30) Priority Data:
PD2009A000250 3 September 2009 (03.09.2009) IT

(71) Applicant (for all designated States except US): **ARPER S.P.A.** [IT/IT]; Via Lombardia, 16, I-31050 Monastier di Treviso (IT).

(72) Inventor; and

(75) Inventor/Applicant (for US only): **FELTRIN, Claudio** [IT/IT]; c/o Arper S.p.A., Via Lombardia, 16, I-31050 Monastier di Treviso (IT).

(74) Agents: **ZANETTIN, Gianluigi** et al.; c/o Jacobacci & Partners S.p.A., Via Berchet, 9, I-35131 Padova (IT).

(81) Designated States (unless otherwise indicated, for every kind of national protection available): AE, AG, AL, AM, AO, AT, AU, AZ, BA, BB, BG, BH, BR, BW, BY, BZ,

CA, CH, CL, CN, CO, CR, CU, CZ, DE, DK, DM, DO, DZ, EC, EE, EG, ES, FI, GB, GD, GE, GH, GM, GT, HN, HR, HU, ID, IL, IN, IS, JP, KE, KG, KM, KN, KP, KR, KZ, LA, LC, LK, LR, LS, LT, LU, LY, MA, MD, ME, MG, MK, MN, MW, MX, MY, MZ, NA, NG, NI, NO, NZ, OM, PE, PG, PH, PL, PT, RO, RS, RU, SC, SD, SE, SG, SK, SL, SM, ST, SV, SY, TH, TJ, TM, TN, TR, TT, TZ, UA, UG, US, UZ, VC, VN, ZA, ZM, ZW.

(84) Designated States (unless otherwise indicated, for every kind of regional protection available): ARIPO (BW, GH, GM, KE, LR, LS, MW, MZ, NA, SD, SL, SZ, TZ, UG, ZM, ZW), Eurasian (AM, AZ, BY, KG, KZ, MD, RU, TJ, TM), European (AL, AT, BE, BG, CH, CY, CZ, DE, DK, EE, ES, FI, FR, GB, GR, HR, HU, IE, IS, IT, LT, LU, LV, MC, MK, MT, NL, NO, PL, PT, RO, SE, SI, SK, SM, TR), OAPI (BF, BJ, CF, CG, CI, CM, GA, GN, GQ, GW, ML, MR, NE, SN, TD, TG).

Declarations under Rule 4.17:

- as to applicant's entitlement to apply for and be granted a patent (Rule 4.17(ii))
- of inventorship (Rule 4.17(iv))

Published:

- with international search report (Art. 21(3))

(54) Title: SEAT ELEMENT

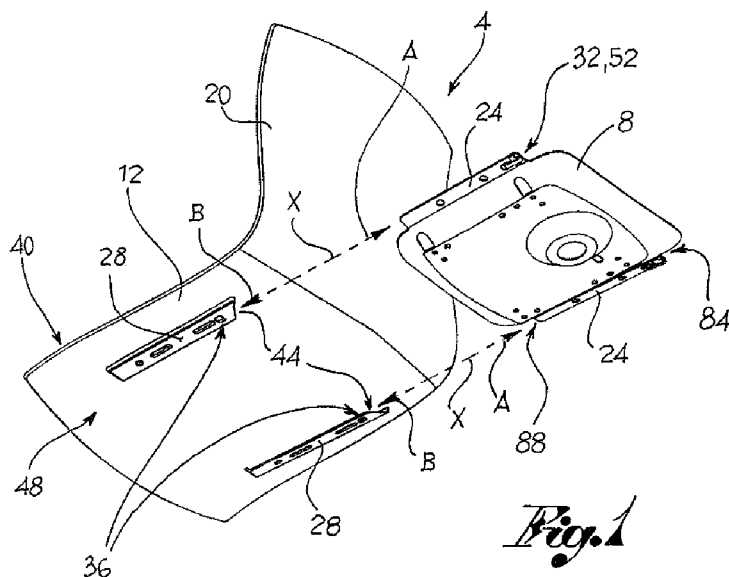

(57) Abstract: A seat element (4) comprising a frame (8), a seat (12) associable to said frame (8), wherein the frame (8) and the seat (12) are made separately from each other and can be engaged and disengaged from each other. Advantageously, the frame (8) comprises at least one lateral plate (24) and the seat (12) comprises at least one tab (28) which, in an assembled configuration, couples at least partially onto said lateral plate (24) in a shaped coupling. Between the at least one tab (28) and the at least one plate (24) a snap coupling element (32) is positioned, which is flexible in relation to the plate (24) and to the tab (28) so as to block the seat (12) to the frame (8) in an assembled configuration of the element (4).

WO 2011/027245 A1

DESCRIPTION**"Seat element"**

[001] The present invention relates to a seat element such as a chair, a stool and the like, comprising a frame and
5 a seat made separately and assembled together.

[002] It is known of in the art to make seats and frames separately, preferably in different materials, to later assemble them together. The interconnection of the seat and the frame is usually performed using rivets, bolts or
10 screws passing through the seat so as to engage in relative holes made in the frame.

[003] Such structures however present the drawback of requiring for their assembly riveting machines or staff specialised in assembling and connecting parts using the
15 aforesaid means of connection.

[004] For such reason, the seat elements of the prior art are normally assembled during the production phase so that the final product is a chair or stool already assembled and ready for use.

20 [005] The pre-assembled structure has the disadvantage however of being cumbersome and unwieldy both during storage and relative transport.

[006] Seat element structures in two separate parts having attachment devices and shaped couplings between relative
25 counter-shaped portions of the frame and the seat are

also known of in the art.

[007] Such attachment devices and shaped couplings do not however ensure a safe and stable attachment over time: in other words with wear, and on account of the inevitable
5 production tolerance, there is often unacceptable and annoying play between the seat and the frame.

[008] Furthermore, the attachment devices of the known art tend to break during assembly and often ruin the seat by abrasion during assembly and subsequent dismantling
10 phases.

[009] The deterioration of the seat, even if on the under part of the seat and therefore not very visible, is not acceptable in the case in which the seat is, for example, upholstered in valuable material. Furthermore, in the
15 case of an upholstered seat, the friction and damage of the covering may lead to jamming of the mechanism.

[0010] The purpose of the present invention is to

[0011] make a seat element which overcomes the drawbacks mentioned with reference to the prior art.

20 [0012] Such drawbacks and limitations are resolved by a seat element according to claim 1.

[0013] Other embodiments of the seat according to the invention are described in the claims below.

[0014] Further characteristics and advantages of the
25 present invention will be more comprehensible from the

description below of its preferred embodiments, made by way of a non-limiting example wherein:

figure 1 shows a perspective view in separate parts of a seat element according to one embodiment of the present invention;

figure 2 shows a ground view from below of the seat element in figure 1, in an assembled configuration;

figure 3 shows a cross-section view of the seat element in figure 1, along the section plane III-III in figure 2;

figures 4-6 show enlarged perspective views of the phases of the assembly process of the seat element in figure 1;

figures 7-8 respectively shows a front view and a ground view from below of a seat element according to a further embodiment of the present invention, in an assembled configuration.

[0015] The elements or parts of elements common to the embodiments described below will be indicated using the same reference numeral.

[0016] With reference to the aforesaid figures, reference numeral 4 globally denotes a seat element; the seat element may be of any type, such as, for example, a chair, a stool or even an armchair or a sump chair.

[0017] The seat element 4 comprises a frame 8 able to support an associable seat 12 and fitted with at least

one means of support 16, such as a foot or a leg.

[0018] The frame 8 is preferably made in metal and is of the tubular type. The means of support 16 may be of any type, such as for example a plurality of legs, a central
5 column fitted with arms, with or without castors, and so on.

[0019] The seat 12 may be of various shapes, materials and sizes and may be with or without a backrest 20.

[0020] The frame 8 and the seat 12 are made separately from
10 each other and can be attached and detached from each other, as better described below.

[0021] Advantageously, the frame (8) comprises at least one lateral plate (24), and the seat (12) comprises at least one tab (28) which in an assembled configuration, hooks
15 onto said lateral plate (24) at least partially, in a shaped coupling.

[0022] Advantageously between the at least one tab (28) and the at least one plate (24) a snap coupling element (32) is positioned, flexible in relation to the plate
20 (24) and to the tab (28) so as to block the seat (12) to the frame (8) in an assembled configuration of the seat element (4).

[0023] According to one embodiment, the at least one plate 24 has a snap coupling element 32, flexible in relation
25 to the at least one plate 24 and at least one tab 28, and

the tab 28 comprises at least one connection seat 36 able to receive the snap coupling element 32 of the plate 24, so as to block the seat 12 to the frame 8 in an assembled configuration of the seat element 4.

5 [0024] Preferably, the seat 12 comprises a pair of tabs 28 and the frame 8 comprises a pair of lateral plates 24 which, in an assembled configuration, guide the relative sliding between the seat 12 and the frame 8 in an axial direction X-X essentially parallel to a seat plane 40.

10 [0025] Preferably, the lateral plates 24 are positioned to overhang the frame 8, at the lateral extremities 42 of the frame 8.

[0026] According to one embodiment, the tabs 28 of the seat 12 define cavities 44 with a lower wall 48 of the seat 12
15 and said cavities 44 house the tabs 28 at least partially, in an assembled configuration of the seat element 4.

[0027] Preferably, the lateral plates 24 and the cavities 44 are directed in an axial direction X-X, so as to form
20 a prismatic coupling along said axial direction X-X. Prismatic coupling is taken to mean a coupling of pure translatory movement which prevents a relative rotation between the two coupled elements.

[0028] According to one embodiment, the snap coupling
25 element 32 is a spring 52 having an attachment base 56 to

the frame 8 and a cantilevered flexible arm 60 provided with one free extremity 64 able to snap engage into the connection seats 36 of the tabs 28 of the seat 12. For example the flexible cantilever arm 60 is connected to the attachment base 56 by a connection portion, for example arc-shaped.

[0029] Preferably, the attachment base 56 is positioned towards the means of support 16, on the side opposite the associable seat 12, so as not to interfere with the seat plane 40.

[0030] In other words, the attachment base 56 is attached to the lateral plate 24 of the frame 8 so as not to interfere with the shaped coupling between the lateral plate 24 and the tab 28.

[0031] Preferably, in an idle condition, the flexible cantilever arm 60 is at least partially closed towards the attachment base 56, so that the free extremity 64 of the spring 52 intersects a plane passing through said attachment base 56.

[0032] According to one embodiment, the plate 24 comprises, at the height of the snap coupling element 32, a through aperture 68 able to allow the passage of said free extremity 64 of the spring 52.

[0033] The free extremity 64 is fitted with a slot portion 72, on the side opposite the attachment base 56, to

facilitate the connection of the spring 52 and a front rim 76 of the tabs 28 of the seat 12, during assembly of the seat element 4 in an insertion direction A.

[0034] The free extremity 64, on the side opposite the slot portion 72 has a pawl 80 able to prevent relative withdrawal of the seat 12 from the frame 8 in a withdrawal direction B opposite said insertion direction A.

[0035] Preferably, the length of the flexible cantilever arm 60 of the spring 52 is such that, in a connection configuration of the free extremity 64 in the connection seat 36, a connection portion 66 between the flexible cantilever arm 60 and the attachment base 56 reaches its final position against a front rim 76 of the tabs 28, so as to form a limit stop to the coupling of the seat 12 and the frame 8.

[0036] Preferably, the spring 52 is positioned at a rear extremity 84 of the plate 24, on the side opposite the front extremity 88 of the plate 24 suitable for being coupled to a front rim 76 of the tabs 28 of the seat 12; this way the spring 52 prevents reverse assembly of the seat 12 on the side of said rear extremity 84 of the plate 24.

[0037] The spring 52 is preferably of the leaf type with a rectangular cross-section.

Preferably the spring is made from crude steel so as to yield to the tabs 28 and to the plates 24.

[0038] The method of assembling a seat element according to the invention will now be described.

5 [0039] In particular, the frame 8 is assembled and the seat 12 brought up to it so as to insert the front extremity 88 of the plates 24 into the cavities 44 delimited by the tabs 28 (figure 4).

[0040] During the coupling of the plates 24 and the tabs 10 28, near the limit stop of the coupling, the front rim 76 of the tabs 28 intercepts the free extremity 64 of the spring 52. This way the flexible cantilever arm 60 rises flexibly to allow the sliding of the tabs (figure 5) until the free extremity encounters the connection seat 15 36 with which it snap couples (figure 6). Preferably, the limit stop occurs contemporarily with the contact between the front rim 76 of the tabs 28 and the connection portion 66 of the spring 52.

[0041] Lastly, to dismantle the seat element 4, it is 20 sufficient to flexibly press the springs 52 so as to disengage the free end 64 from the connection seat 36 and contemporarily slide the seat 12 in relation to the frame 8 so as to pull out the plates 24 from the tabs completely 28.

25 [0042] For example, a screwdriver may be used for the

purpose, inserting the tip between the flexible cantilever arm 60 of the spring 52 and the tab 28 of the seat 12.

[0043] As may be appreciated from the description, the seat element according to the invention makes it possible to overcome the drawbacks spoken of in relation to the prior art.

[0044] In particular, the seat element is particularly practical and easy to assemble and dismantle.

[0045] The coupling and detachment element does not cause any abrasion of the seat or seat covering where present.

[0046] The coupling element is sturdy and does not break even if the assembly and dismantling phase is performed repeatedly.

[0047] The coupling element is small and practically invisible in conditions of normal use of the seat element.

[0048] The cost of producing and assembling the coupling element is extremely limited and does not substantially influence the overall cost of the seat element.

[0049] Thanks to the present invention it is possible to store and transport the seat elements in an easy and practical manner.

[0050] Lastly, the number of machines and the labour used to produce the seat elements is reduced.

[0051] A person skilled in the art may make numerous modifications and variations to the seat elements described above so as to satisfy contingent and specific requirements while remaining within the sphere of protection of the invention as defined by the following claims.

Claims

1. Seat element (4), comprising
- a frame (8) able to support an associable seat (12) and
5 fitted with at least one means of support (16), such as a
foot or a leg,
 - a seat (12) associable to said frame (8),
 - the frame (8) and the seat (12) being made separately
from each other and being attachable and detachable from
10 each other,
- characterised by the fact that
- the frame (8) comprises at least one lateral plate
(24),
 - the seat (12) comprises at least one tab (28) which in
15 an assembled configuration, hooks onto said lateral plate
(24) at least partially, in a shaped coupling, wherein
 - between the at least one tab (28) and at least one
plate (24) a snap coupling element (32) is positioned,
flexible in relation to the plate (24) and to the tab
20 (28) so as to block the seat (12) to the frame (8) in an
assembled configuration of the seat element (4).
2. Seat element (4) according to claim 1, wherein the
at least one plate (24) has a snap coupling element
(32), flexible in relation to the at least one plate (24)
25 and at least one tab (28), and the tab (28) comprising at

12

least one connection seat (36) is able to receive the snap coupling element (32) of the plate (24), so as to block the seat (12) to the frame (8) in an assembled configuration of the seat element (4).

5 3. Seat element (4) according to claim 1 or 2, wherein the seat (12) comprises a pair of tabs (28) and the frame (8) comprises a pair of lateral plates (24) which, in an assembled configuration, guide the relative sliding between the seat (12) and the frame (8) in an axial
10 direction (X-X) essentially parallel to a seat plane (40).

4. Seat element (4) according to claim 1, 2 or 3, wherein the tabs (28) of the seat (12) define cavities (44) with a lower wall (48) of the seat (12) and said
15 cavities (44) house the tabs (28) at least partially, in an assembled configuration of the seat element (4).

5. Seat element (4) according to any of the previous claims, wherein the lateral plates (24) and the cavities (44) are directed in an axial direction (X-X), so as to
20 form a prismatic coupling along said axial direction (X-X).

6. Seat element (4) according to any of the previous claims, wherein the lateral plates (24) are positioned to overhang the frame (8), at the lateral extremities (42)
25 of the frame (8).

7. Seat element (4) according to any of the previous claims, wherein the snap coupling element (32) is a spring (52) having an attachment base (56) to the frame (8) and a cantilevered flexible arm (60) provided with
5 one free extremity (64) able to snap engage into the connection seats (36) of the tabs (28) of the seat (12).

8. Seat element (4) according to claim 7, wherein the attachment base (56) is positioned towards the means of support (16), on the side opposite the associable seat
10 (12), so as not to interfere with the seat plane (40).

9. Seat element (4) according to claim 7 or 8, wherein, in an idle condition, the flexible cantilever arm (60) is at least partially closed towards the attachment base (56), so that the free extremity (64) of the spring (52)
15 intersects a plane passing through said attachment base (56).

10. Seat element (4) according to any of the previous claims from 7 to 9, wherein the plate (24) comprises, at the height of the snap coupling element (32), a through
20 aperture (68) able to allow the passage of said free extremity (64) of the spring (52).

11. Seat element (4) according to any of the previous claims from 7 to 10, wherein the free extremity (64) is fitted with a slot portion (72), on the side opposite the
25 attachment base (56), to facilitate the connection of the

14

spring (52) and a front rim (76) of the tabs (28) of the seat (12), during assembly of the seat element (4) in an insertion direction (A).

12. Seat element (4) according to claim 11, wherein the
5 free extremity (64) opposite the slot portion (72), has a pawl (80) able to prevent relative withdrawal of the seat (12) from the frame (8) in a withdrawal direction (B) opposite said insertion direction (A).

13. Seat element (4) according to any of the previous
10 claims from 7 to 12, wherein the length of the flexible cantilever arm (60) of the spring (52) is such that, in a connection configuration of the free extremity (64) in the connection seat (36), a connection portion (66) between the flexible cantilever arm (60) and the
15 attachment base (56) reaches its final position against a front rim (76) of the tabs (28), so as to form a limit stop to the coupling of the seat (12) and the frame (8).

14. Seat element (4) according to any of the previous
claims from 7 to 13, wherein the spring (52) is
20 positioned at a rear extremity (84) of the plate (24), on the side opposite the front extremity (88) of the plate (24) suitable for being coupled to a front rim (76) of the tabs (28) of the seat (12), the spring (52) preventing reverse assembly of the seat (12) on the side
25 of said rear extremity (84) of the plate (24).

15

15. Seat element (4) according to any of the previous claims from 7 to 13, wherein the spring (52) is made from crude steel so as to yield to the tabs (28) and to the plates (24).

5

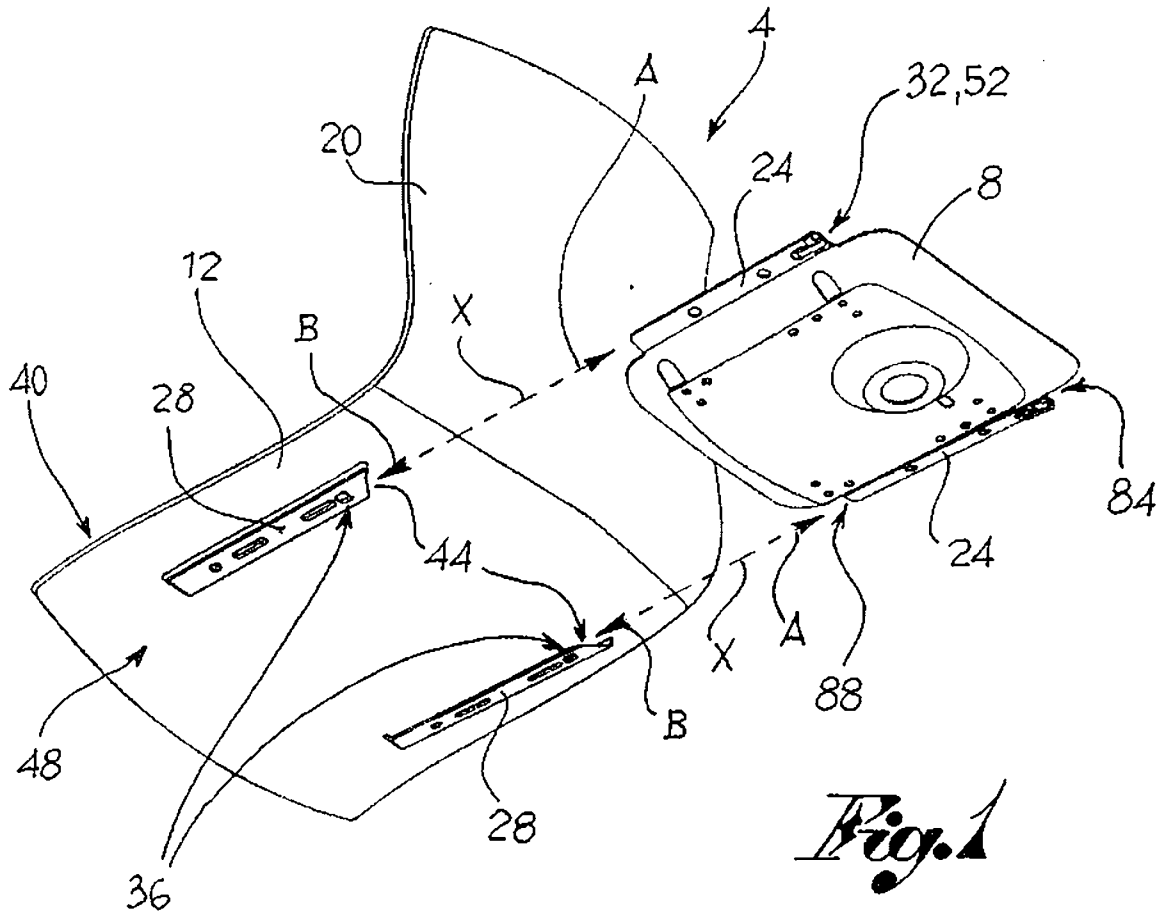

Fig. 1

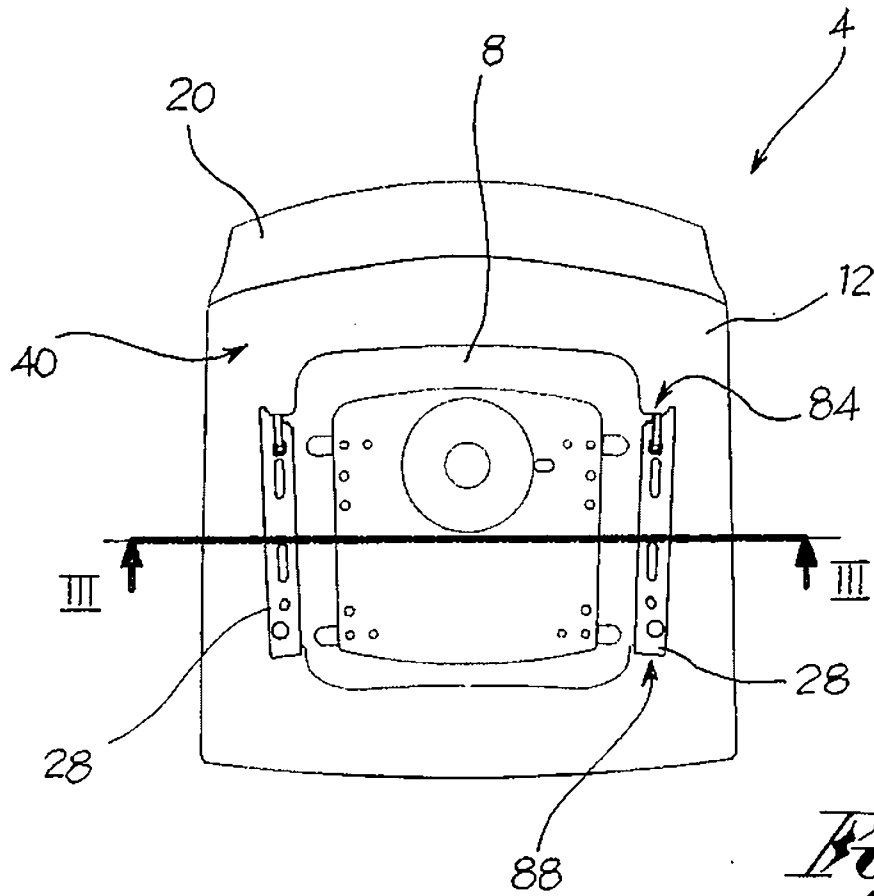

Fig. 2

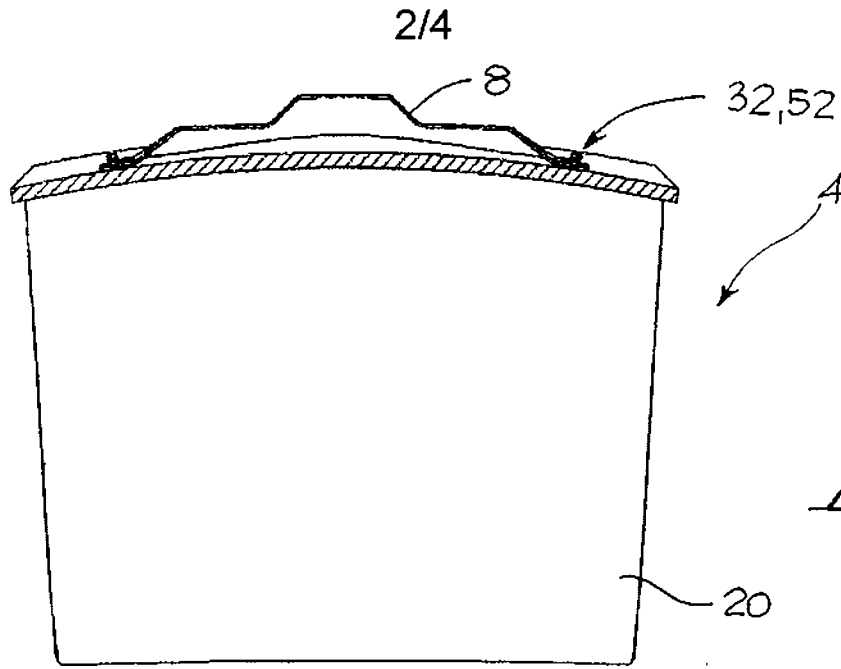

Fig. 3

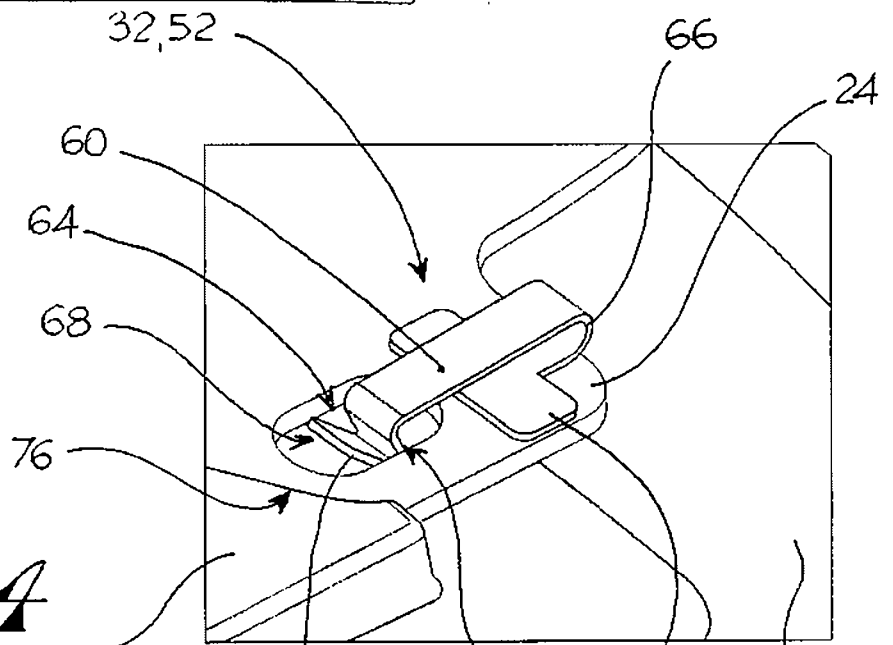

Fig. 4

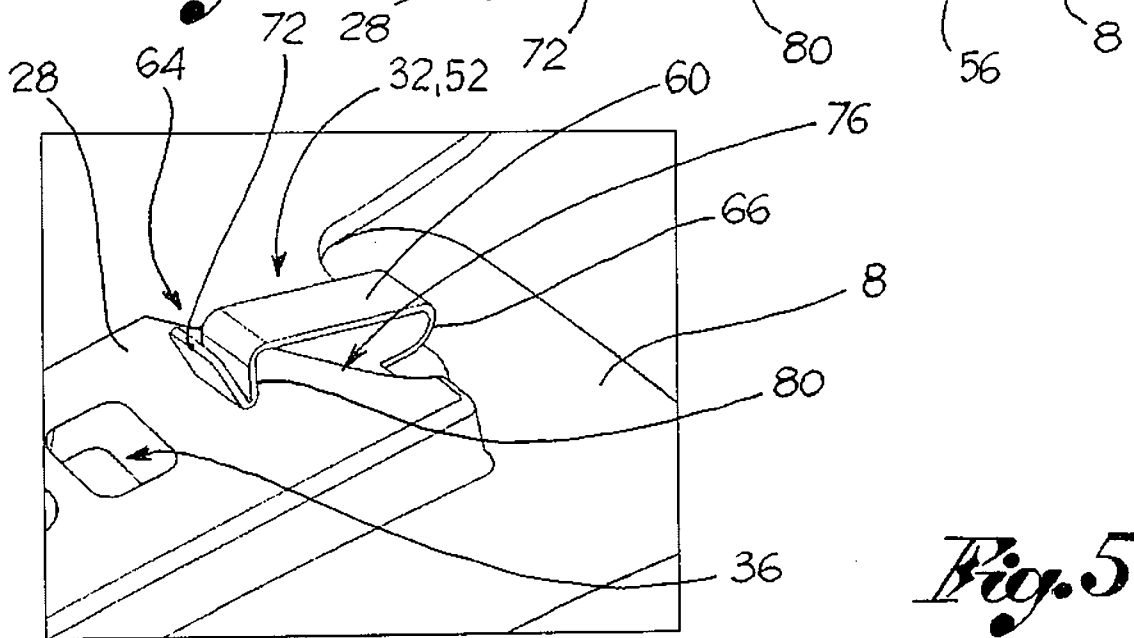

Fig. 5

3/4

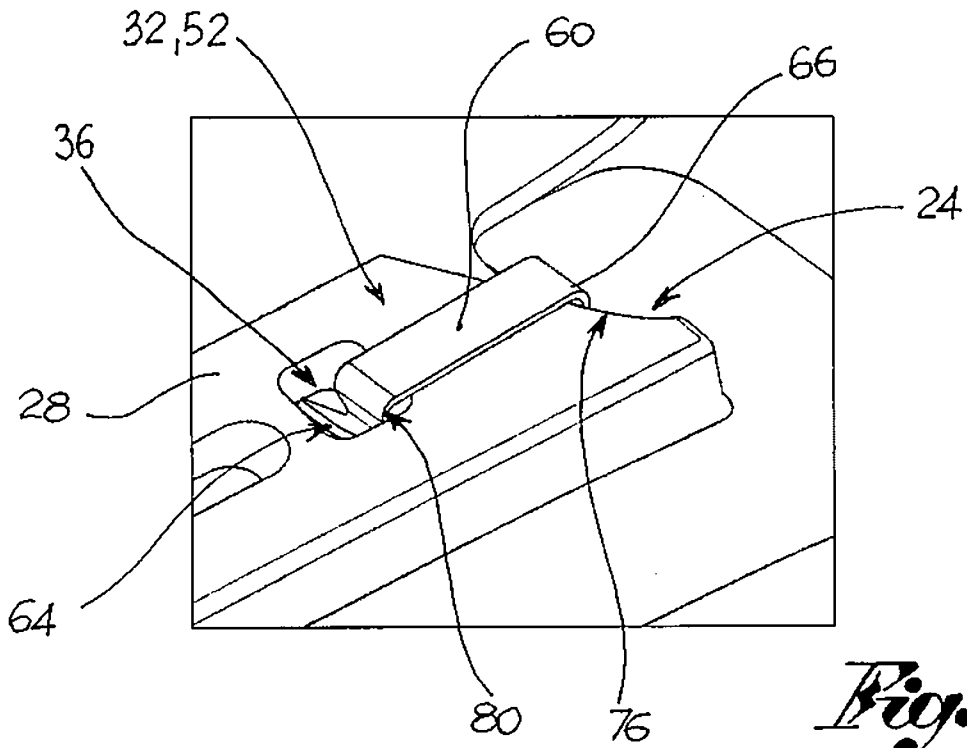

Fig. 6

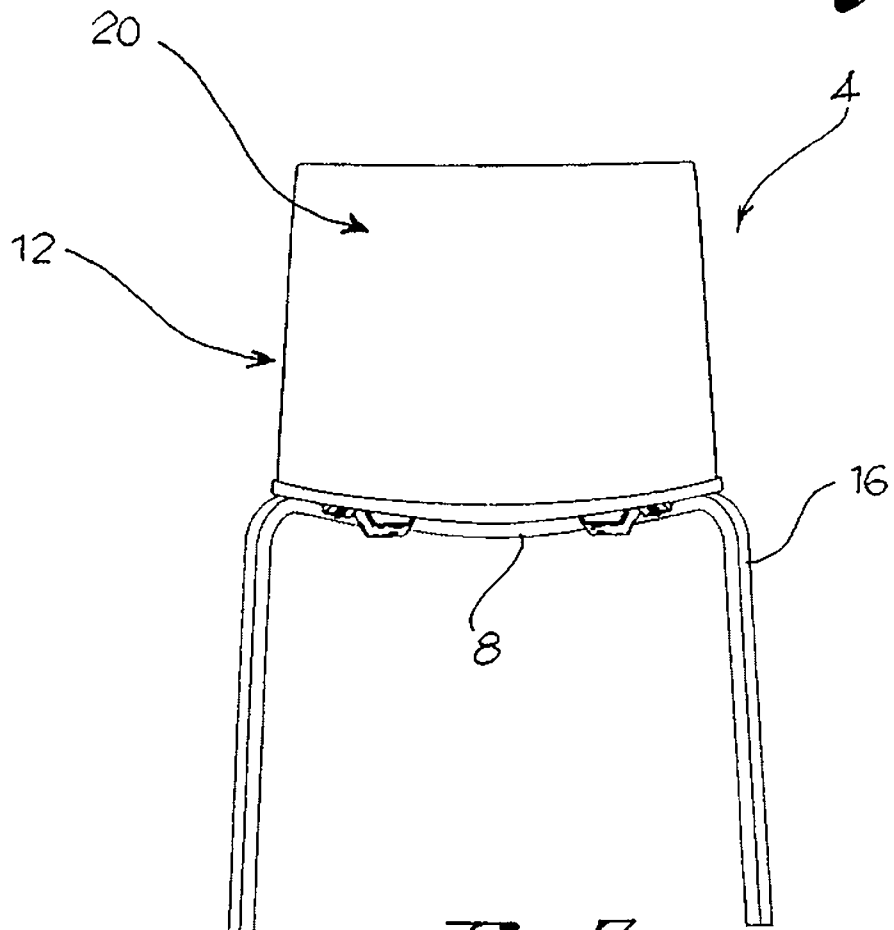

Fig. 7

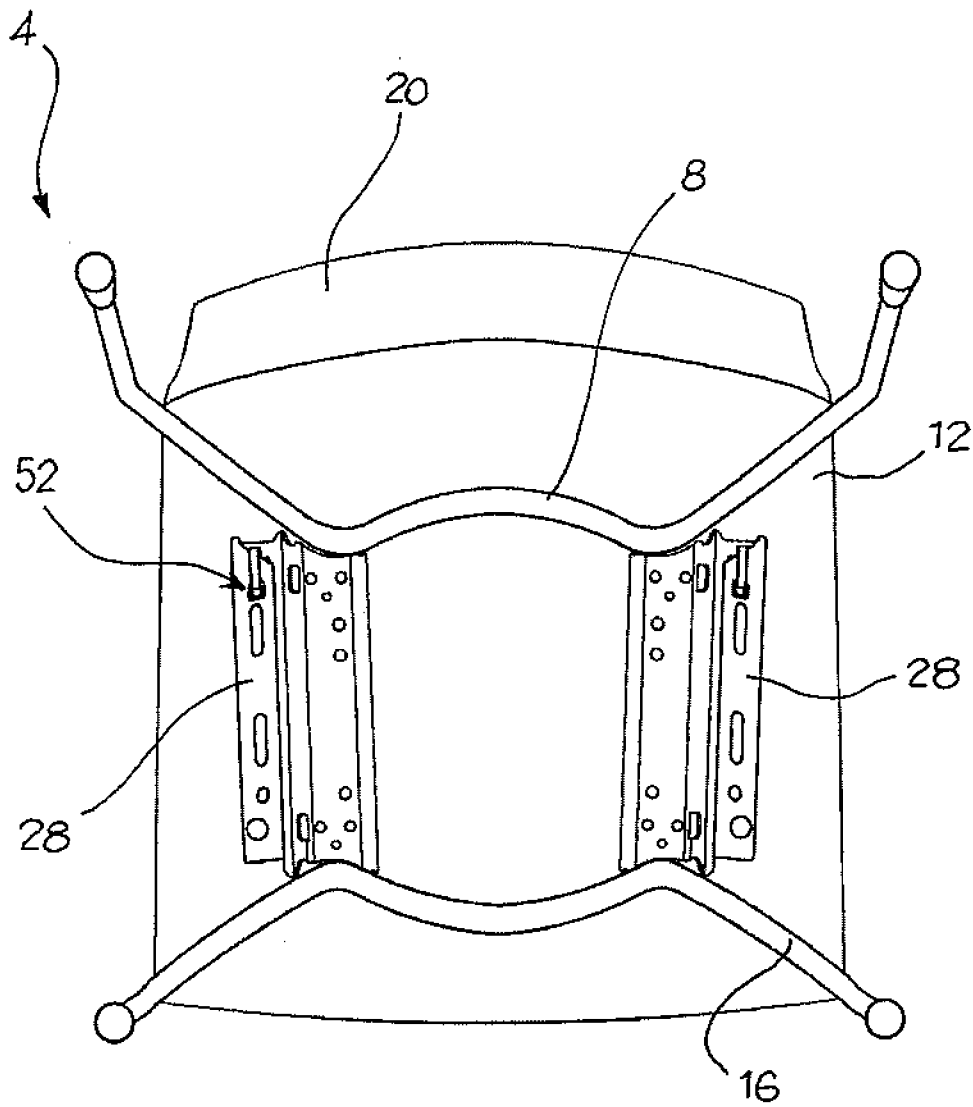

Fig. 8

INTERNATIONAL SEARCH REPORT

International application No
PCT/IB2010/053571

A. CLASSIFICATION OF SUBJECT MATTER

INV. A47C4/02

ADD.

According to International Patent Classification (IPC) or to both national classification and IPC

B. FIELDS SEARCHED

Minimum documentation searched (classification system followed by classification symbols)

A47C

Documentation searched other than minimum documentation to the extent that such documents are included in the fields searched

Electronic data base consulted during the international search (name of data base and, where practical, search terms used)

EPO-Internal

C. DOCUMENTS CONSIDERED TO BE RELEVANT

| Category* | Citation of document, with indication, where appropriate, of the relevant passages | Relevant to claim No. |
|-----------|---|-----------------------|
| A | WO 2008/140752 A1 (L & P PROPERTY MANAGEMENT CO [US]; COSTAGLIA MASSIMO [IT]; SLONGO ALES) 20 November 2008 (2008-11-20) the whole document | 1-15 |
| A | US 2006/273642 A1 (LIN PO-YI [TW] ET AL) 7 December 2006 (2006-12-07) the whole document | 1-15 |
| A | US 2004/245840 A1 (TUBERGEN RENARD G [US] ET AL) 9 December 2004 (2004-12-09) the whole document | 1-15 |

 Further documents are listed in the continuation of Box C. See patent family annex.

* Special categories of cited documents :

"A" document defining the general state of the art which is not considered to be of particular relevance

"E" earlier document but published on or after the international filing date

"L" document which may throw doubts on priority claim(s) or which is cited to establish the publication date of another citation or other special reason (as specified)

"O" document referring to an oral disclosure, use, exhibition or other means

"P" document published prior to the international filing date but later than the priority date claimed

"T" later document published after the international filing date or priority date and not in conflict with the application but cited to understand the principle or theory underlying the invention

"X" document of particular relevance; the claimed invention cannot be considered novel or cannot be considered to involve an inventive step when the document is taken alone

"Y" document of particular relevance; the claimed invention cannot be considered to involve an inventive step when the document is combined with one or more other such documents, such combination being obvious to a person skilled in the art.

"&" document member of the same patent family

Date of the actual completion of the international search

12 November 2010

Date of mailing of the international search report

19/11/2010

Name and mailing address of the ISA/

European Patent Office, P.B. 5818 Patentlaan 2
NL - 2280 HV Rijswijk
Tel. (+31-70) 340-2040,
Fax: (+31-70) 340-3016

Authorized officer

Cardan, Cosmin

INTERNATIONAL SEARCH REPORT

Information on patent family members

International application No

PCT/IB2010/053571

| Patent document cited in search report | Publication date | Patent family member(s) | Publication date |
|---|---------------------|----------------------------|---------------------|
| WO 2008140752 A1 | 20-11-2008 | EP 2144537 A1 | 20-01-2010 |
| US 2006273642 A1 | 07-12-2006 | NONE | |
| US 2004245840 A1 | 09-12-2004 | AU 2003272280 A1 | 30-04-2004 |
| | | AU 2004245072 A1 | 16-12-2004 |
| | | BR 0314234 A | 09-08-2005 |
| | | BR PI0411047 A | 11-07-2006 |
| | | CA 2498395 A1 | 25-03-2004 |
| | | CA 2528041 A1 | 16-12-2004 |
| | | CN 1822780 A | 23-08-2006 |
| | | CN 1822781 A | 23-08-2006 |
| | | EP 1578230 A2 | 28-09-2005 |
| | | EP 1483986 A1 | 08-12-2004 |
| | | EP 1628554 A2 | 01-03-2006 |
| | | JP 4562532 B2 | 13-10-2010 |
| | | JP 2006513807 T | 27-04-2006 |
| | | JP 2006526484 T | 24-11-2006 |
| | | KR 20050037000 A | 20-04-2005 |
| | | MX PA05002605 A | 08-06-2005 |
| | | TW 257294 B | 01-07-2006 |
| | | WO 2004023934 A2 | 25-03-2004 |
| | | US 2006170263 A1 | 03-08-2006 |
| | | US 2004245839 A1 | 09-12-2004 |
| | | US 2004051358 A1 | 18-03-2004 |
| | | US 2007114827 A1 | 24-05-2007 |
| | | US 2007228800 A1 | 04-10-2007 |
| | | US 2004245827 A1 | 09-12-2004 |
| | | US 2004245841 A1 | 09-12-2004 |
| | | WO 2004107915 A2 | 16-12-2004 |