



INTERNATIONAL APPLICATION PUBLISHED UNDER THE PATENT COOPERATION TREATY (PCT)

(51) International Patent Classification <sup>6</sup> : <b>B01F 3/12, 13/06, 15/02, A61F 2/46</b>	A1	(11) International Publication Number: <b>WO 99/67015</b>
		(43) International Publication Date: 29 December 1999 (29.12.99)

(21) International Application Number: PCT/DK98/00208

(22) International Filing Date: 22 May 1998 (22.05.98)

(30) Priority Data:  
0584/97 21 May 1997 (21.05.97) DK

(71) Applicant (for all designated States except US): NIKOMED APS [DK/DK]; Formervangen 5, DK-2600 Glostrup (DK).

(72) Inventor; and  
(75) Inventor/Applicant (for US only): KORNERUP, Niels [DK/DK]; Gl. Vallerødvej 31 A, DK-2960 Rungsted Kyst (DK).

(74) Agent: OSTENFELD PATENTBUREAU A/S; Bredgade 41, P.O. Box 1183, DK-1011 Copenhagen K. (DK).

(81) Designated States: AL, AM, AT, AT (Utility model), AU, AZ, BA, BB, BG, BR, BY, CA, CH, CN, CU, CZ, CZ (Utility model), DE, DE (Utility model), DK, DK (Utility model), EE, EE (Utility model), ES, FI, FI (Utility model), GB, GE, GH, GM, GW, HU, ID, IL, IS, JP, KE, KG, KP, KR, KZ, LC, LK, LR, LS, LT, LU, LV, MD, MG, MK, MN, MW, MX, NO, NZ, PL, PT, RO, RU, SD, SE, SG, SI, SK, SK (Utility model), SL, TJ, TM, TR, TT, UA, UG, US, UZ, VN, YU, ZW, ARIPO patent (GH, GM, KE, LS, MW, SD, SZ, UG, ZW), Eurasian patent (AM, AZ, BY, KG, KZ, MD, RU, TJ, TM), European patent (AT, BE, CH, CY, DE, DK, ES, FI, FR, GB, GR, IE, IT, LU, MC, NL, PT, SE), OAPI patent (BF, BJ, CF, CG, CI, CM, GA, GN, ML, MR, NE, SN, TD, TG).

**Published**  
With international search report.

(54) Title: AN APPARATUS FOR PREPARING BONE CEMENT

(57) Abstract

An apparatus for preparing bone cement from two or more constituents contained in respective sealed containers comprises a housing defining an open first end and a closed second end opposite each other. A piston body is received within the housing defining an inner chamber of the housing. The apparatus further comprises at least two receptor assemblies communicating with the inner chamber of the housing through respective inlets which are shiftable between an open state and a closed state, in which open state communication is established from the receptor assemblies to the inner chamber of the housing, and in which closed state communication to the inner chamber of the housing through the inlets is blocked. Each of the receptor assemblies comprises a receptor for receiving a respective sealed container and for establishing a leakage-proof communication from within the respective sealed container to the inner chamber of the housing. The apparatus further comprises a stirring means received within the housing being operable from outside the housing and being movable within the housing and an ejector tube connected to the housing at the second end thereof. The ejector tube is shiftable between a first state and a second state, in which first state communication from the inner chamber of the housing through the ejector tube is blocked and in which second state communication from the inner chamber of the housing is established through the ejector tube to the environment.

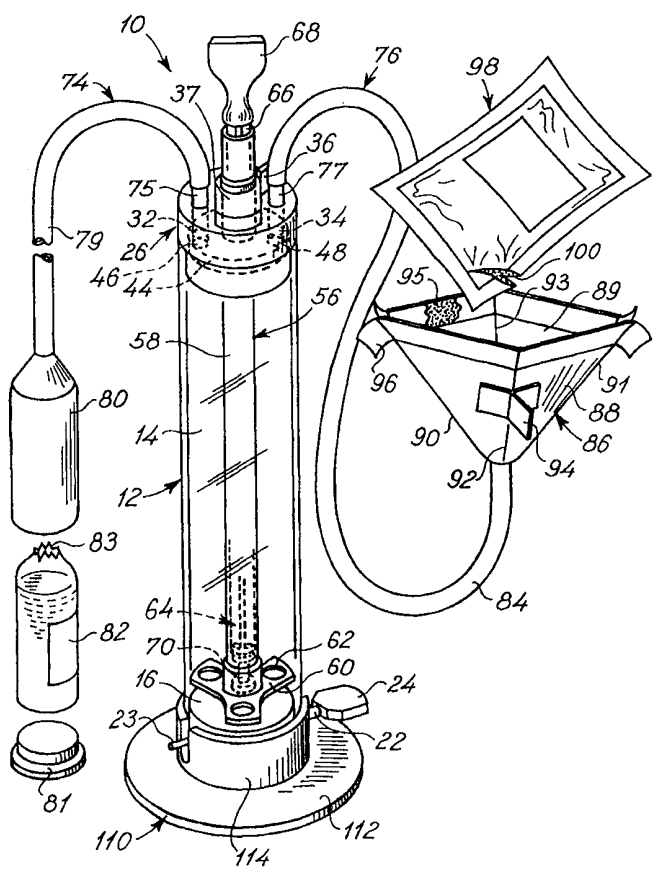

*FOR THE PURPOSES OF INFORMATION ONLY*

Codes used to identify States party to the PCT on the front pages of pamphlets publishing international applications under the PCT.

AL	Albania	ES	Spain	LS	Lesotho	SI	Slovenia
AM	Armenia	FI	Finland	LT	Lithuania	SK	Slovakia
AT	Austria	FR	France	LU	Luxembourg	SN	Senegal
AU	Australia	GA	Gabon	LV	Latvia	SZ	Swaziland
AZ	Azerbaijan	GB	United Kingdom	MC	Monaco	TD	Chad
BA	Bosnia and Herzegovina	GE	Georgia	MD	Republic of Moldova	TG	Togo
BB	Barbados	GH	Ghana	MG	Madagascar	TJ	Tajikistan
BE	Belgium	GN	Guinea	MK	The former Yugoslav Republic of Macedonia	TM	Turkmenistan
BF	Burkina Faso	GR	Greece	ML	Mali	TR	Turkey
BG	Bulgaria	HU	Hungary	MN	Mongolia	TT	Trinidad and Tobago
BJ	Benin	IE	Ireland	MR	Mauritania	UA	Ukraine
BR	Brazil	IL	Israel	MW	Malawi	UG	Uganda
BY	Belarus	IS	Iceland	MX	Mexico	US	United States of America
CA	Canada	IT	Italy	NE	Niger	UZ	Uzbekistan
CF	Central African Republic	JP	Japan	NL	Netherlands	VN	Viet Nam
CG	Congo	KE	Kenya	NO	Norway	YU	Yugoslavia
CH	Switzerland	KG	Kyrgyzstan	NZ	New Zealand	ZW	Zimbabwe
CI	Côte d'Ivoire	KP	Democratic People's Republic of Korea	PL	Poland		
CM	Cameroon	KR	Republic of Korea	PT	Portugal		
CN	China	KZ	Kazakstan	RO	Romania		
CU	Cuba	LC	Saint Lucia	RU	Russian Federation		
CZ	Czech Republic	LI	Liechtenstein	SD	Sudan		
DE	Germany	LK	Sri Lanka	SE	Sweden		
DK	Denmark	LR	Liberia	SG	Singapore		
EE	Estonia						

## An apparatus for preparing bone cement

5 The present invention relates to an apparatus for preparing bone cement from two or more constituents contained in respective sealed containers.

Numerous apparatuses of the above kind for producing bone cement by mixing two constituents together for preparing the bone cement are known. Examples of prior art apparatuses are described in EP 0470959, WO 95/00240, WO 94/26403, WO 93/22041, EP 0674888, DE 4302230, 10 EP 0178658, EP 0528447 and SE 447785.

An apparatus of the present type usually comprises a cylindrical syringe housing in which a stirring piston is present by means of which the two constituents usually constituting a liquid constituent and a powder 15 constituent are mixed after the constituents are introduced into the interior of the housing. The housing also includes a piston body by means of which the bone cement mixture prepared in the apparatus may be expelled by means of an applicator gun through an ejector tube.

In several apparatuses described in the above publications, the constituents from which the bone cement is to be prepared are readily 20 introduced into an inner chamber of the apparatus by breaking the sealed containers in which the constituents are contained and simply pouring the constituents into the interior of the apparatus through one or more funnels. An example of the bone cement to be prepared by means of an apparatus of this kind is the commercial bone cement mixture manufactured by the 25 US company Schering-Plough and sold under the tradename PALACOS® R. It has been realized that the constituents from which the bone cement is to be prepared are highly toxic and may cause injuries to the person or persons preparing the bone cement from the constituents by means of an apparatus of the above described type.

30 According to some technical solutions, the entire apparatus is to be contained in an evacuated chamber in which the bone cement is to be prepared; however, this technical solution is inconvenient as the preparation of the bone cement from the two or more constituents involves a mechanical mixing of the constituents together which necessitates that 35 the person or persons preparing the bone cement mixture is able to mechanically operate the apparatus and perform a physical work by means of a mixing or stirring piston of the apparatus. According to an alternative

technical solution, the toxic gases and the toxic or skin-irritating powder constituents are stated to be prevented from contacting the person or persons preparing the bone cement mixture from the constituents by evacuating the interior of the mixing apparatus by means of a vacuum source; however, experiments performed by the applicant have clearly demonstrated that liberation of toxic gases and expelling of powder material from the mixing chamber cannot be prevented, even in case the  
5 mixing chamber is evacuated by means of a vacuum source.

An object of the present invention is to provide an apparatus of the above described kind for preparing a bone cement mixture from two or more constituents, at least one of which constitutes a toxic or skin-irritating constituent, which apparatus prevents the constituents from which the bone cement mixture is to be prepared, at least the toxic or skin-irritating constituent, from being liberated or expelled from the apparatus during any step of the process of preparing the bone cement mixture.  
10 15

An advantage of the present invention relates to the fact that the bone cement preparing and mixing apparatus according to the present invention allows the constituents from which the bone cement mixture is to be prepared to be introduced into the mixing or preparing apparatus without leaking gas, liquid or powder material to the atmosphere.  
20

A particular feature of the present invention relates to the fact that the bone cement preparing apparatus according to the present invention allows all steps of the operation of preparing the bone cement mixture from two or more constituents, at least one of which constitutes a toxic or skin-irritating constituent, in a non-gas-, liquid- and powder-leaking state, which steps involve pouring or introducing the constituents into the apparatus, and mechanically mixing the constituents together for preparing the bone cement mixture.  
25

A particular advantage of the present invention relates to the fact that in the bone cement mixing and preparing apparatus according to the present invention the two or more constituents from which the bone cement mixture is to be prepared are transferred from sealed containers in closed off or sealed receptors to the interior of the apparatus and further mixed in a mechanical mixing operation within the apparatus without leaking gas, liquid or powder to the environment for exposure of the person preparing the mixture or persons present in the vicinity of the bone cement mixing and preparing apparatus from toxic or skin-irritating gases,  
30 35

liquids or powder materials.

5 A further advantage of the present invention relates to the fact that no materials including gaseous, liquid and powder materials are liberated from the bone cement mixing and preparing apparatus during the process of introducing the two or more constituents from which the bone cement is to be mixed into the apparatus and during the process of mixing the constituents together until the bone cement prepared by means of the apparatus according to the present invention is expelled by the surgeon by means of the apparatus constituting an applicator apparatus to be received in an applicator gun for expelling the bone cement.

10 The above object, the above feature and the above advantages together with numerous other objects, features and advantages which will be evident from the below detailed description of preferred embodiments of the present invention are in accordance with the teachings of the present invention obtained by an apparatus for preparing bone cement from two or more constituents contained in respective sealed containers, comprising:

- 15 i) a housing defining opposite first and second ends and an inner cylindrical wall, the first end being open and the second end being closed,
- 20 ii) a piston body received within the housing and sealing against the inner cylindrical wall, the piston body and the housing together defining an inner chamber of the housing, the piston body being movable from the first end towards the second end for diminishing the inner chamber of the housing,
- 25 iii) at least two receptor assemblies communicating with the inner chamber of the housing through respective inlets, the inlets being shiftable between an open state and a closed state, in which open state communication is established from the receptor assemblies to the inner chamber of the housing, and in which closed state communication to the inner chamber of the housing through the inlets is blocked, each of the receptor assemblies comprising a receptor for receiving a respective sealed container and for establishing a leakage-proof communication from within the respective sealed container to the inner chamber of the housing through the respective receptor assembly and the respective inlet for transferring  
30 the constituents in the respective sealed container to the inner chamber of the housing,
- 35 iv) stirring means received within the housing, the stirring means

being operable from outside the housing and being movable within the housing for mixing together the constituents received within the inner chamber of the housing for preparing the bone cement, and

5 v) an ejector tube connected to the housing at the second end thereof and for expelling the bone cement prepared within the inner chamber of the housing by moving the piston body from the first end towards the second end for diminishing the inner chamber, the ejector tube being shiftable between a first state and a second state, in which first state  
10 communication from the inner chamber of the housing through the ejector tube is blocked and in which second state communication from the inner chamber of the housing is established through the ejector tube to the environment.

According to the teachings of the present invention, the constituents from which the bone cement mixture is to be prepared are transferred  
15 from the sealed containers in which the constituents are initially contained to the inner chamber of the housing of the apparatus, as the sealed containers are received in respective receptors of the receptor assemblies, in which receptors leakage-proof communication from the sealed containers to the inner chamber of the housing is established, allowing  
20 transfer of the constituents from the sealed containers to the inner chamber of the housing without risking leaking of gaseous, fluid or solid materials to the environment.

It is to be realized that the apparatus according to the present invention further provides the advantage of allowing the individual preparing the  
25 bone cement mixture to position the constituents within the respective receptor assemblies a fairly long period of time before carrying out the mixing or stirring operation and consequently prepare the apparatus according to the present invention in a ready-to-use-state in which the bone cement mixture is simply prepared within an extremely short period of  
30 time including the time for transferring the constituents from the receptor assemblies and stirring the bone cement mixture by means of the stirring means, however, eliminating the time of positioning or arranging the constituents within the respective receptor assemblies. In this context, it is to be recognized that the usual time of solidification of bone cement  
35 mixtures are of the order of 5-6 minutes meaning that the bone cement mixture has to be used within a fairly short period of time of the order of 2-4 minutes after the bone cement mixture has been prepared. Therefore,

the bone cement mixture cannot be produced in advance but need to be produced at the time the surgeon tells that the bone cement mixture is to be prepared. Consequently, by the elimination of the time period for positioning or arranging the constituents within the two receptor assemblies, the overall time spent by the surgeon waiting for the bone cement mixture to be prepared is to a great extent shortened as compared to the prior art bone cement mixture apparatuses as the apparatus according to the present invention as discussed above allows the apparatus to be prepared in a ready-to-use state in which the preparation or production of the bone cement mixture involves the transfer of the constituents from the two receptor assemblies to the housing and the operation of stirring the constituents together.

The apparatus according to the present invention may include receptor assemblies fulfilling the objects, advantages and features characteristic of the present invention adapted to specific types and kinds of containers which may be constituted by glass bottles, plastic containers, such as plastic bottles, plastic bags, foil bags, capsules, etc. and allowing that the container containing the constituents from which the bone cement is to be prepared to be perforated or opened within the receptor or prior to introducing the container or containers into the respective receptors, and in doing so performing a swift introduction of the container or containers in question into the respective receptors preventing to any substantial extent evaporation or liberation of gases, liquids or powder material from the container or containers.

For allowing the container or containers containing the constituents from which the bone cement is to be prepared to be received by the respective receptors without risking the apparatus being physically moved and overturned, the receptor assemblies preferably further comprise respective flexible hoses interconnecting the respective receptors and the respective inlets. Consequently, the individual receptors may easily be handled by the person preparing the bone cement mixture, and handled in any appropriate orientation allowed by the presence of the hoses being flexible hoses interconnecting the receptors and the respective inlets. According to specific advantageous embodiments, at least one of the receptor assemblies comprises an openable container constituting the respective receptor for receiving and enclosing the respective sealed container containing one of the constituents constituting a liquid constituent

to be expelled from its respective sealed container after breaking the sealed container, or alternatively comprises a funnel-shaped receptor. According to the first-mentioned advantageous embodiment, the receptor is adapted to receive and enclose a sealed container, such as a bottle, e.g. a glass or plastic bottle containing a liquid or powder constituent. According to the second advantageous embodiment, the receptor constituted by a funnel-shaped receptor is through its adhesive coating applied to its inner surface adapted to seal against the foil bag and establish a leakage-proof communication from the interior of the foil bag to the inner chamber of the housing of the apparatus for transfer of liquid or powder constituents from the foil bag.

According to a further embodiment of the above funnel-shaped receptor, the funnel-shaped receptor is foldable and collapsible and has gripping flaps for allowing the foldable and collapsible funnel-shaped receptor to be agitated for promoting the expelling of the powder constituent contained within the foil bag. The stirring means of the apparatus according to the present invention may be constituted by any appropriate means including a stirring body and a stirring rod, or alternatively a stirring body which is operable from outside the housing, e.g. through a threaded connection, a magnetic coupling, etc. The stirring body of the presently preferred embodiment according to the present invention is positioned within the inner chamber and connected to the stirring rod which extends through an opening at the second end of the housing, as a seal is provided at the opening for sealing the stirring rod relative to the housing at the opening for preventing leaking of gaseous, liquid or powder substances or materials through the opening through which the stirring rod extends.

The ejector tube of the apparatus according to the present invention may be constituted by a separate component which may be integrally connected to the housing, or alternatively mounted on the housing after the preparation of the bone cement mixture and is shiftable between the first and second state through perforating a perforating foil or wall component prior to ejecting the bone cement mixture from the inner chamber of the housing in which the bone cement mixture is prepared. According to an advantageous and presently preferred embodiment of the apparatus according to the present invention, the ejector tube and the stirring rod of the stirring means are integrated into a single component as the stirring rod



is composed of a hollow tube constituting the ejector tube and an inner rod extending lengthwise through the hollow tube defining the first state of the ejector tube and being removable from its position within the hollow tube defining the second state of the ejector tube.

5       The housing of the apparatus according to the present invention may per se have any appropriate configuration fulfilling the purposes of the housing of the apparatus according to the present invention. The cylindrical inner wall of the housing may have any appropriate generator, such as a square, a rectangle, an ellipse, and preferably a circle, meaning  
10       that the inner cylindrical wall constitutes a circular-cylindrical inner wall allowing that the piston body be simply constituted by a circular-cylindrical body which in a rotational symmetrical manner readily fits into the inner cylindrical wall of the housing.

15       For preventing that the piston body be unintentionally shifted from its position at the first end of the housing to a position at the second end of the housing, the piston body is preferably arrestable by means of arresting means relative to the housing at the first end of the housing. The arresting means may be constituted by any per se well-known means within the art, such as a screw rod, a bayonet lock, a locking pin, etc.

20       The shifting of the inlets from the open state to the closed state, and optionally vice versa, may be accomplished in any appropriate manner by means of a separate closing element constituting an external component or an internal component of the apparatus, which component may be moved from a position corresponding to the closed state of the inlet to a different  
25       position constituting the open state of the inlet. It is further to be realized that the closing of the inlets and the opening of the inlets need not be accomplished by means of a single element or component providing a simultaneous closing and/or opening of the inlets. According to a first advantageous embodiment of the apparatus according to the present  
30       invention, the inlets are blocked in the closed state by a shiftable closer plate provided within the housing at the second end thereof and being shiftable from a first position in which the inlets are blocked to a second position in which the inlets are not blocked. Alternatively, according to the presently preferred embodiment of the apparatus according to the present  
35       invention, the inlets are blockable by means of individual plugs to be inserted into the inlets for defining the closed state.

In accordance with the realization described in numerous of the above

patent publications, the mixing of the two constituents for producing the bone cement is preferably carried out while any excessive gas is evacuated from the mixing chamber. Consequently, the apparatus according to the present invention preferably further comprises an evacuation channel  
5 communicating with the inner chamber of the housing for evacuating the inner chamber of the housing by means of an external vacuum source.

The present invention is now to be further described with reference to the drawings, in which

Fig. 1 is an overall perspective and schematic view of a first  
10 embodiment of a bone cement mixing apparatus according to the present invention illustrating a first step of mixing a two-constituent bone cement within the apparatus,

Fig. 2 is a view similar to the view of Fig. 1 illustrating a second step of mixing the two-constituent bone cement within the apparatus,

15 Fig. 3 is a view similar to the views of Figs. 1 and 2 illustrating a third step of mixing the two-constituent bone cement within the apparatus,

Fig. 4 is a view similar to the views of Figs. 1-3 illustrating a fourth step of mixing the two-constituent bone cement within the apparatus,

20 Fig. 5 is an exploded view of the first embodiment of the bone cement mixing apparatus according to the present invention also illustrated in Figs. 1-4,

Fig. 6 is a perspective and schematic view illustrating the first embodiment of the apparatus according to the present invention mounted within a bone cement applicator gun,

25 Fig. 7 is an overall perspective, schematic top view of a modified embodiment of the bone cement mixing apparatus according to the present invention,

30 Fig. 8 is a view similar to the view of Fig. 7 of a further modified embodiment of the bone cement mixing apparatus according to the present invention,

Fig. 9 is an overall perspective and schematic view of a further and presently preferred embodiment of the bone cement mixing apparatus according to the present invention, and

35 Fig. 10 is a view similar to the view of Fig. 9 of a twin portion mixing version of the presently preferred embodiment of the bone cement mixing apparatus according to the present invention.

In the below description, components or elements of identical structure and serving the same function in different embodiments are designated the same reference numerals and components or elements of a further embodiment serving the same purpose as a previously described component or element, however, modified in relation to the previously described component or element is designated the same reference numeral, yet added a single or a multiple marking. In the present context, the expressions "upper " and "lower" refer, unless otherwise indicated, to the orientation of the apparatus during the process of preparing a bone cement mixture, in which instance the apparatus is positioned on a supporting surface such as a table and extends substantially vertically upwards from the supporting surface.

In Figs. 1 and 5, a first embodiment of a bone cement mixing apparatus according to the present invention is shown designated the reference numeral 10 in its entirety. The apparatus 10 basically constitutes a combined bone cement mixing apparatus and bone cement applicator apparatus as will be evident from the below description. The apparatus comprises a housing 12 which is composed of a circular-cylindrical wall component 14 defining opposite upper and lower end parts. At the lower end part, a closure plug 16 is mounted slidably within the circular-cylindrical wall component 14. The closure plug 16 is, as is evident from Fig. 5, provided with a radial groove in which a sealing O-ring 18 is received. A diametrical bore 20 is provided extending through the lower part of the closure plug 16 below the sealing O-ring 18 serving the purpose of receiving an arresting pin 22 which is mounted extending through opposite bores produced in the wall component 14 opposite the diametrical bore 20 for fixating and arresting the closure plug 16 relative to the wall component 14. The arresting pin 22 is at its one end provided with a reduced diameter part 23 and at its opposite end provided with a handle 24 serving the purpose of allowing a person using the apparatus 10 to remove the arresting pin 22 from its position fixating and arresting the closure plug 16, i.e. from the position illustrated in Fig. 1 after the completion of the bone cement mixing procedure.

At the upper end, the annular cylindrical wall component 14 is sealed by a top closure cap 26 which is composed of two parts, a solid body top part 27 and a downwardly protruding annular part 28 having a reduced outer diameter which corresponds to and mates with the inner diameter of

the annular cylindrical wall component 14. The top closure cap 26 is sealed to the circular-cylindrical wall component 14 through an adhesive or welded joint as the lower annular part 28 of the top closure cap 26 is received within the annular cylindrical wall component 14.

5 Through the solid body part 27 of the top closure cap 26, an axial through-going bore 30 extends, and two additional through-going bores 32 and 34 are produced in the solid body top part 27 of the top closure cap 26 as is evident from Fig. 5. The through-going bores 32 and 34 are produced diametrically opposite one another in relation to the axial bore 30. From  
10 the top surface of the top closure cap 26, a radially extending fin 36 protrudes. Within the axial bore 30, a turnable knob 37 is provided. The knob 37 has a lower annular cylindrical skirt part 38 through which a concentric through-going bore 39 is produced. Through the outer wall of the annular cylindrical skirt part 38, the turnable knob 37 is received  
15 within the through-going axial bore 30 of the top closure cap 26.

Within the inner chamber defined behind the lower annular part 28 of the top closure cap 26 a further component 40 is received. The component 40 is basically composed of two parts, firstly a tubular top part 42 and a  
20 disc-shaped circular part 44. The disc-shaped cylindrical part 44 is provided with two through-going bores 46 and 48 which may be positioned in registration with the through-going bores 32 and 34, respectively, of the top closure part 26. Within recesses produced in the top part of the through-going bores 46 and 48, two sealing O-rings 50 and 52,  
25 respectively, are received for sealing against the lower surface of the solid body part 27 of the top closure cap 26. In a circumferential outer groove of the disc-shaped circular part 44, a further sealing O-ring 54 is received for sealing against the inner surface of the lower annular part 28 of the top closure cap 26.

As the component 40 is received within the inner chamber defined  
30 behind the lower annular part 28 of the top closure cap 26, the tubular part 42 extends through the through-going bore 30 of the top closure cap 26 and further into the through-going bore 39 of the turnable knob 37 and is fixated relative to the knob 37. The knob 37 and the component 40 are connected to one another in an angular orientation so as to position the  
35 through-going bores 46 and 48 of the disc-shaped circular part 44 away from registration with the through-going bores 32 and 34 of the solid body part 27 of the top closure cap 26, provided the knob 37 is positioned in

radial continuation of the radially extending fin 36, whereas the through-going bores 46 and 48 of the disc-shaped circular part 44 of the component 40 are positioned in registration with the through-going bores 32 and 34 of the solid body part 27 of the top closure cap 26, provided the turnable  
5 knob 37 is positioned in a specific angular orientation relative to the radially extending fin 36.

The bone cement mixing apparatus 10 further comprises a stirring assembly shown in the right-hand part of the exploded view of Fig. 5 and designated the reference numeral 56. The stirring assembly 56 comprises  
10 an elongated tubular element 58 defining opposite open ends. At the lower open end of the tubular element 58, a three-bladed plate element 60 is arranged defining three individual blade elements each apertured by a through-going hole 62. The stirring assembly 56 further comprises a rod  
15 64 which during the initial steps of preparing a bone cement mixture by means of the bone cement preparing apparatus 10 is mounted within the elongated tubular element 58 of the stirring assembly 56 for providing a closure at the lower end of the elongated tubular element 58 and sealing  
20 off the passage within the interior of the elongated tubular element 58. The rod 64 basically includes a central body portion 66 terminating at the upper end in a handle 68 and terminating at the opposite lower end in a plug part 70 which is composed of two circular disc-shaped elements 71 and 72 which are kept in spaced-apart relationship by a pin element 73.  
25 The circular disc-shaped element 72 positioned juxtaposed the central body portion 66 is provided with an outer circumferential recess for receiving a sealing O-ring 69. The stirring assembly 56 is in the assembled state of the apparatus 10 mounted within the interior of the housing 12 extending  
through the inner through-going passage of the tubular top part 42 of the component 40 as is illustrated in Fig. 1.

In Fig. 1, the apparatus 10 is, as stated above, illustrated in a first step  
30 of preparing a bone cement mixture as the apparatus is mounted on a stand 110 in an upright position. The stand 110 basically comprises a circular disc-shaped supporting plate 112 for resting and supporting the apparatus on a supporting surface, such as the surface of a table at which a person, such as a nurse, is to prepare a bone cement mixture by means of the  
35 apparatus. From the circular disc-shaped supporting plate 112, an annular skirt 114 extends upwardly for receiving and arresting the lower end part of the housing 12 as is seen in Fig. 1. The annular skirt 114 is provided

with longitudinally extending slits for receiving the arresting pin 22 and the reduced diameter part 23 thereof, and at the same time for preventing the housing 12 from turning relative to the stand 110.

In Fig. 1, the through-going bores 46 and 48 of the disc-shaped circular part 44 are arranged in registration with the through-going bores 32 and 34 of the solid body part 27 of the top closure cap 26 for providing communication to the interior of the apparatus 10 through two tube assemblies 74 and 76, respectively, which are connected to the top closure cap 26 through tube connectors 75 and 77, respectively. The tube assembly 74 basically comprises a hose 79 which defines opposite ends, one of which is connected to the connector 75, whereas the opposite end is integrally connected to a receptor 80. The receptor 80 is sealable by means of a closure plug 81. The receptor 80 is configured or shaped so as to allow a bottle 82 including a liquid constituent of the two-component bone cement mixture to be received and supported within the interior sealed chamber defined within the receptor 80 after the neck of the bottle 82 is broken off as indicated by the reference numeral 62. After the bottle is introduced into the interior of the receptor 80, the closure plug 81 is press-fitted into sealing engagement with the lower open end of the receptor 80. It is to be realized that the hose 79 has a length, as is evident from Fig. 1, preventing the receptor 80 from resting on the supporting surface, such as the table on which the apparatus 10 rests supported in the stand 110 so as to present the initially opened or unsealed receptor 80 freely hanging in the hose 89 and presenting the open lower end of the receptor 80 at a height above the supporting surface of the table, allowing the person preparing the bone cement mixture to readily introduce the bottle 82 into the interior of the receptor 80 by simply lifting the bottle 82 into the interior of the receptor 80 and thereupon closing the open lower end of the receptor by means of the plug 81.

For introducing the other constituent of the two-component bone cement mixture into the interior of the apparatus 10, the other tube assembly 76 comprising a hose 84 similar to the hose 74 is present, however differing from the tube assembly 74 in that the hose 84 has a length substantially exceeding the length of the hose 74 and allowing a receptor 86 of the tube assembly 76 to rest on the supporting surface on which the apparatus 10 is positioned and rests supported by the stand 110. The receptor 86 further differs from the receptor 80 in that the receptor 86

constitutes a foldable or collapsible funnel 86 composed of two opposite  
triangularly shaped walls 88 and 89 which are joined together along joints  
90 and 91 and which are foldable away from one another along folding  
lines or weakening lines 92 and 93, respectively. The foldable and  
5 collapsible funnel 86 is erectable from a collapsed state by means of  
gripping flaps provided at the outer side surfaces of the triangularly shaped  
walls 88 and 89 at the weakening or folding lines 92 and 93, respectively,  
one of which gripping flaps is shown in Fig. 1 and designated the  
reference numeral 94. The oppositely positioned gripping flap provided at  
10 the outer side surface of the triangularly shaped wall 89 is hidden in the  
illustration of Fig. 1.

Along the inner side of the triangularly shaped walls 88 and 89 two  
adhesive coatings, one of which is designated the reference numeral 95,  
are provided at the upper edges of the foldable and collapsible funnel 86.  
15 The joints 90 and 91 interconnecting the triangularly shaped walls 88 and  
89 terminate a short distance below the upper edges of the triangularly  
shaped walls 88 and 89 for presenting freely accessible gripping flaps, one  
of which is designated the reference numeral 96, of release papers  
covering the adhesive coatings which are described above and one of  
20 which is designated the reference numeral 95.

The foldable and collapsible funnel 86 is adapted to receive and seal  
around a bag 98 containing a powder constituent of the two-component  
bone cement mixture, which bag is opened by cutting a slit 100 at one  
corner of the bag 98 by means of a knife or a pair of scissors. After the  
25 bag 98 has been opened by cutting the slit 100 and completely opened by  
removing the cut-off end piece of the bag separated by the slit 100, the bag  
is introduced into the interior of the foldable and collapsible funnel 86 in  
the position shown in Fig. 1, without spilling any powdered material from  
the bag 98, or, alternatively, in an inversed position by positioning the  
30 funnel 86 embracing or encircling the bag 98 from above whereupon the  
foldable and collapsible funnel 86 is adhered to the outer walls of the bag  
98 for sealing the opening produced in the bag 98 by the slit 100 by  
tearing the release papers off, which release papers are gripped by the  
person preparing the bone cement mixture by gripping the flaps, one of  
35 which is designated the reference numeral 96. After the exposure of the  
adhesive coatings, one of which is designated the reference numeral 95,  
the funnel 86 is pressed against the bag 98 for causing the adhesives at the

upper edge of the inner sides of the triangularly shaped walls 88 and 89 of the funnel 86 to adhere to the bag 98 for sealing off the interior of the bag 98 from the environment. As will be understood, the bottle 82 as well as the bag 98 are now kept in sealed receptors preventing the liquid and powder constituents of the bottle 82 and the bag 98, respectively, from being spilt or otherwise unintentionally allowed to be liberated into the atmosphere and consequently exposed to the person preparing the bone cement mixture by means of the apparatus 10.

The first step of preparing the bone cement mixture by means of the apparatus 10 is now terminated. Now, turning to Fig. 2 which illustrates the next or second step of preparing the bone cement mixture, the receptor 80 is raised, allowing the liquid constituent contained within the bottle 82 to flow into the hose 79 of the tube assembly 74 and further into the interior of the apparatus 10, as illustrated by liquid drops 102. Similarly, the bag 98 is caused to deliver the powder constituent to the interior of the apparatus 10 as the person preparing the bone cement mixture grips the gripping flaps, one of which is shown in solid line in Fig. 2 and designated the reference numeral 94, and brings the gripping flaps apart as illustrated by arrows in Fig. 2, one of which is designated the reference numeral 106, for opening the foldable and collapsible funnel 86 and at the same time mechanically agitating or shaking the bag 98 which is adhered to and sealed off relative to the inner sides of the walls 88 and 89 of the funnel 86. The powder delivered from the bag 98 falls into the interior of the apparatus 10 as illustrated by particulate powder 104.

The liquid and powder constituents from which the bone cement mixture is to be prepared has now been transferred from the bottle 82 and the bag 98, respectively, into the interior of the housing 12 of the apparatus 10. The liquid and powder constituents are now to be mixed together, as is illustrated in Fig. 3, in a mechanical mixing operation in which the person preparing the bone cement mixture raises and lowers the stirring assembly 56 as indicated by an arrow 108 in Fig. 3 for causing the three-bladed plate element 60 to stir the liquid and powder constituents contained within the interior of the housing 12 for preparing the bone cement mixture.

In Fig. 3, the hoses 74 and 84 are also shown and arrows 116 and 118 indicate that the hoses 74 and 84 may be used for evacuating the interior of the housing 12 during the process of agitating and mixing the liquid and



powder constituents of the two-component bone cement mixture together. Alternatively, the evacuation of the interior of the apparatus for mixing the two-constituent bone cement mixture together may in an alternative embodiment 10' illustrated in Fig. 7 be carried out by means of a separate evacuation hose 120. In fig. 7, the modified housing 12' is provided with a modified top closure cap 26' in which a further through-going bore 124 is produced, in which through-going bore a connector 121 is received for establishing connection to the hose 120 similar to the connection established between the hoses 74 and 84 by means of the connectors 75 and 77, respectively. The evacuation through the hose 120 is schematically illustrated by an arrow 122. In Fig. 7, the modified disc-shaped circular part 44' is further provided with an additional through-going passage or bore 126 which may be positioned in registration with the through-going bore 124 of the top closure cap 26' for establishing communication from the interior of the housing 12' through the hose 120 to an evacuation source, not shown in the drawings. Whereas the through-going bores 46 and 48 of the disc-shaped circular part 44' are positioned in communication to the hoses 74 and 84, respectively, through the through-going bores 32 and 34, respectively, of the top closure cap 26' in one and the same position of the disc-shaped part 24' relative to the top closure cap 26', the through-going bore 126 is not at the same time positioned in registration with the through-going bore 124. Thus, provided the communication from the receptors 80 and 96 through the hoses 74 and 84 is established through the hoses 74 and 84, respectively, and further through the bores 46 and 48 of the disc-shaped circular part 44, the through-going bores 124 and 126 are not at the same time positioned in registration to one another. Similarly, provided the through-going bores 124 and 126 are positioned in registration to one another, as illustrated in Fig. 7, the through-going bores 46 and 48 of the disc-shaped circular part 44' are not at the same time positioned in registration with the through-going bores 32 and 34 of the top closure cap 26'.

In Fig. 8, a further modified embodiment 10'' of the bone cement mixing apparatus according to the present invention is shown, comprising a separate evacuation hose 120'. The evacuation hose 120' for evacuating the interior of the housing 12'' as illustrated by the arrow 120' is connected to the housing 12'' through a side aperture which extends through the circular cylindrical wall component 14' and in which the

connector 121' is received. In Fig. 8, the through-going bores 32 and 34 of the top closure cap are sealed by means of two plugs 128 and 130, respectively. After finalizing the mixing operation, after which the evacuation of the interior of the housing 12'' is discontinued, the  
5 connector 121' of the hose 120' is removed from the through-going bore extending through the circular cylindrical wall component 14' and the through-going aperture is sealed off by engaging the reduced diameter part 23 of the arresting pin in the through-going bore and breaking off the reduced diameter part 23 from the remaining part of the arresting pin 22.

10 After the finalizing of the mixing operation as described above with reference to Fig. 3, or alternatively as described above with reference to the alternative embodiments 10' and 10'' illustrated in Figs. 7 and 8, respectively, the bone cement mixing apparatus according to the present invention is to be transformed into an applicator syringe. The conversion  
15 into the applicator syringe is carried out by turning the knob 37 for sealing off the communication between the through-going bores 32 and 34 of the top closure cap 26 and the through-going bores 46 and 48 of the disc-shaped circular part 44 and positioning the knob 37 in radial registration with the radially extending fin 36 as is illustrated in Fig. 4. Thereupon, the  
20 rod 64 is extracted from the interior of the elongated tubular element 58, as is illustrated in Fig. 4 by an arrow 132, for allowing the bone cement mixture present within the interior of the housing 12 to be expelled through the elongated tubular element 58, serving as an ejector tube. At the stage of extracting the rod 64 from the interior of the elongated tubular  
25 element 58, the stirring assembly 56 is also raised to its top position in which the three-bladed plate element 60 is concealed within the interior of the annular part 28 of the top closure cap 26. The apparatus 10 is then introduced into an applicator gun 140, as is illustrated in Fig. 6.

The applicator gun 140 is of a basically conventional structure and no  
30 detailed discussion of the applicator gun is being presented here, as numerous applicator guns are described in the prior art. A single important feature is, however, to be described, namely the configuration of a front plate 142 of the applicator gun 140, in which front plate a radial recess 144 is provided, which recess is configured so as to only allow the  
35 apparatus 10 to be received within the applicator gun 140 provided the knob 37 and the radially extending fin 36 are positioned in radial alignment, corresponding to a position of the disc-shaped circular part 44

relative to the top closure cap 26, in which position the through-going bores 46 and 48 are not communicating with or positioned in alignment with the through-going bores 32 and 34, respectively, of the top closure cap 26. Prior to introducing the apparatus 10 into the applicator gun 140, the arresting pin 22 is also removed, allowing the closure plug 16 to serve as a piston body which is forced into the inner chamber of the housing 12 for expelling the bone cement mixture from the apparatus through the elongated tubular element 58 serving as an ejector tube.

In Fig. 9, a further and presently preferred embodiment of the apparatus according to the present invention is shown designated the reference numeral 10''' in its entirety. The apparatus 10''' is of an overall structure similar to the structure of the above described apparatus 10 illustrated in Figs. 1-6, however, differing from the apparatus 10 in that the apparatus 10''' is of a more simple structure in which the rotatable disc-shaped circular part 44 is omitted. Instead of sealing off the communication established through the top closure cap 26 illustrated in Figs. 1 and 5, by rotating the disc-shaped circular part 44 described above, the through-going bores 32 and 34 of the top closure cap 26'' illustrated in Fig. 9 are simply closed off by means of plugs 128' and 130' similar to the plugs 128 and 130 described above with reference to Fig. 8, which plugs 128' and 130' are connected or linked to the top closure cap 26'' through connecting bands 129 and 131, respectively, preventing the plugs 128' and 130' from being dispositioned or lost. Apart from the simplification of the entire apparatus by the omission of the rotatable disc-shaped circular part 44 discussed above, the apparatus 10''' illustrated in Fig. 9 is furthermore defined through the provision of a linking band 132 by means of which the closure plug 81' is connected to the receptor 82'. Similarly, the connectors 75' and 77' of the tube assemblies 74' and 76', respectively, are provided with closure plugs 133 and 135, respectively which are linked to the connectors 75' and 77', respectively, through linking bands 137 and 141, respectively.

In Fig. 10, a further modification of the above described presently preferred embodiment of the apparatus 10''' is shown, in which modification the tube assemblies 74'' and 76'' are provided with Y-branchings as the tube assembly 74'' comprises two identical receptors 80' for receiving two individual bottles 82, each containing one portion of the liquid constituent of the bone cement mixture. Similarly, the tube assembly

76' comprises two foldable and collapsible funnels 86' for receiving a total of two bags, each containing a portion of the powder constituent of the bone cement mixture. The modified apparatus 10''' illustrated in Fig. 10 consequently allows the mixing of a bone cement mixture twice as big  
5 as the portion prepared from a single bottle 82 and a single bag 98 as described above with reference to Figs. 1-9.

### Example

10 A prototype embodiment of the presently preferred embodiment of the apparatus according to the present invention 10''' illustrated in Fig. 9 was made from the following components. The circular cylindrical wall component 14 was made from a length of 220 mm of a tube made from Nylon 11 having an inner diameter of 38 mm and an outer diameter of 42  
15 mm. The top closure cap 26 was machined from Nylon 11 defining an outer diameter of 46 mm. A lower circumferential recess was machined in the top closure cap 26 for allowing the top closure cap to be highfrequency welded to the circular-cylindrical wall component 14. The elongated tubular element 58 of the stirring assembly 56 was made from a length of  
20 270 mm tube of Nylon 11, the inner diameter of the tube being 10 mm and the outer diameter of the tube being 12 mm. The three-bladed plate element 60 was also made from Nylon 11. The rod 64 defined an overall length of 300 mm and was assembled from individual components made of Nylon 11 which were glued and welded together in the structure illustrated  
25 in Figs. 1, 5 and 9. The sealing O-ring 69 was a conventional rubber sealing ring. The hose 79 and the hose 89 of the tube assemblies 74' and 76', respectively, were both made from PVC hoses, and the hose 76 had an overall length of 250 mm and the hose 89 had an overall length of 540 mm. The receptor 80' was made from a Nylon 11 container defining an  
30 overall length of 100 mm, an outer diameter of 25,5 mm and an inner diameter of 22,5 mm, and the closure plug 81' was also made from Nylon 11. The collapsible funnel 86 was made from foil material which was adhered to the outer free end of the hose 89 by means of an adhesive. The triangularly shaped walls 88 and 90 were made from PVC foil, each  
35 measuring at their widest opening 195 mm and a distance to the vertex of the triangle from the free top edges of the triangle measuring 100 mm. The connectors 75' and 77' were produced from Nylon 11. The stand 110

was an aluminum stand. The arresting pin 22 was a Nylon 11 plug of the configuration illustrated in Fig. 5 and defining a total length of 70 mm.

5 Although the invention has been described above with reference to a specific advantageous embodiment, it is to be construed that numerous modifications may be made without departing from the scope of the invention as defined in the appending claims. In particular, the apparatus may for some applications be modified into an apparatus for mixing more than two constituents, such as three or more constituents, and the ejector tube constituted by the elongated tubular element 58 may be substituted by  
10 separate tubular elements connectable to the top closure cap through a junction, which junction is offset relative to the longitudinal axis of the housing 12. Provided a separate ejector tube is provided, the stirring assembly 56 may similarly be modified by closing off the lower end of the tubular element 58 or simply substituting the tubular element 58 with a  
15 solid rod.

**CLAIMS**

1. An apparatus for preparing bone cement from two or more constituents contained in respective sealed containers, comprising:

- 5        i)     a housing defining opposite first and second ends and an inner cylindrical wall, said first end being open and said second end being closed,
- ii)     a piston body received within said housing and sealing against said inner cylindrical wall, said piston body and said housing together
- 10        defining an inner chamber of said housing, said piston body being movable from said first end towards said second end for diminishing said inner chamber of said housing,
- iii)    at least two receptor assemblies communicating with said inner chamber of said housing through respective inlets, said inlets being
- 15        shiftable between an open state and a closed state, in which open state communication is established from said receptor assemblies to said inner chamber of said housing, and in which closed state communication to said inner chamber of said housing through said inlets is blocked, each of said
- 20        receptor assemblies comprising a receptor for receiving a respective sealed container and for establishing a leakage-proof communication from within said respective sealed container to said inner chamber of said housing through said respective receptor assembly and said respective inlet for transferring said constituents in said respective sealed container to said inner chamber of said housing,
- 25        iv)    stirring means received within said housing, said stirring means being operable from outside said housing and being movable within said housing for mixing together said constituents received within said inner chamber of said housing for preparing said bone cement, and
- v)     an ejector tube connected to said housing at said second end
- 30        thereof and for expelling said bone cement prepared within said inner chamber of said housing by moving said piston body from said first end towards said second end for diminishing said inner chamber, said ejector tube being shiftable between a first state and a second state, in which first state communication from said inner chamber of said housing through said
- 35        ejector tube is blocked and in which second state communication from said inner chamber of said housing is established through said ejector tube to the environment.

2. The apparatus according to claim 1, said receptor assemblies further comprising respective flexible hoses interconnecting said respective receptors and said respective inlets.

5

3. The apparatus according to any of the claims 1 and 2, at least one of said receptor assemblies comprising an openable container constituting said respective receptor for receiving and enclosing said respective sealed container containing one of said constituents constituting a liquid constituent to be expelled from its respective sealed container after breaking said sealed container.

10

4. The apparatus according to any of the claims 1-3, at least one of said receptor assemblies comprising a funnel-shaped receptor for receiving a foil bag constituting one of said respective sealed containers and containing a powder constituent, said funnel-shaped receptor being provided with an adhesive coating at its inner surface for adhering to the outer surface of said foil bag and sealing against the outer surface of said foil bag.

15

20

5. The apparatus according to claim 4, said funnel-shaped receptor being foldable and collapsible and having gripping flaps for allowing said foldable and collapsible funnel-shaped receptor to be agitated for promoting the expelling of said powder constituent contained within said foil bag.

25

6. The apparatus according to any of the claims 1-5, said stirring means comprising a stirring body and a stirring rod, said stirring body being positioned within said inner chamber and connected to said stirring rod, said stirring rod extending through an opening at said second end of said housing, and a seal being provided at said opening for sealing said stirring rod relative to said housing at said opening.

30

7. The apparatus according to claim 6, said stirring rod being composed of a hollow tube constituting said ejector tube and an inner rod extending lengthwise through said hollow tube defining said first state of said ejector tube and being removable from its position within said hollow

35

tube defining said second state of said ejector tube.

8. The apparatus according to any of the claims 1-7, said inner cylindrical wall constituting a circular-cylindrical inner wall.

5

9. The apparatus according to any of the claims 1-8, said piston body being arrestable by means of an arresting means relative to said housing at said first end of said housing.

10

10. The apparatus according to claim 9, said arresting means being constituted by a locking pin.

15

11. The apparatus according to any of the claims 1-10, said inlets being blocked in said closed state by a shiftable closure plate provided within said housing at said second end thereof and being shiftable from a first position in which said inlets are blocked to a second position in which said inlets are not blocked.

20

12. The apparatus according to any of the claims 1-11, said inlets being blockable by means of individual plugs to be inserted into said inlets for defining said closed state.

25

13. The apparatus according to any of the claims 1-12, further comprising an evacuation channel communicating with said inner chamber of said housing for evacuating said inner chamber of said housing by means of an external vacuum source.



Fig. 1

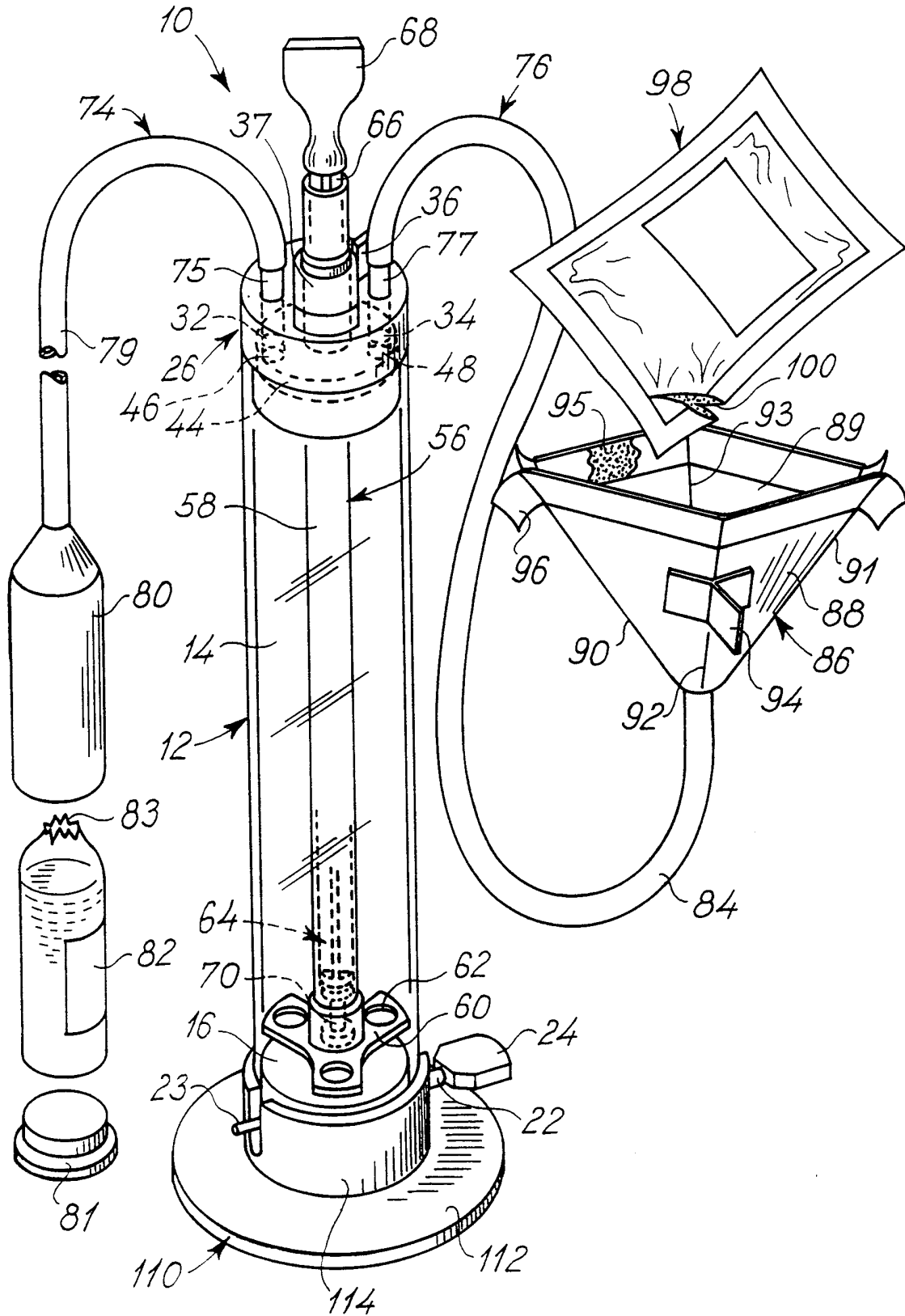

Fig. 2

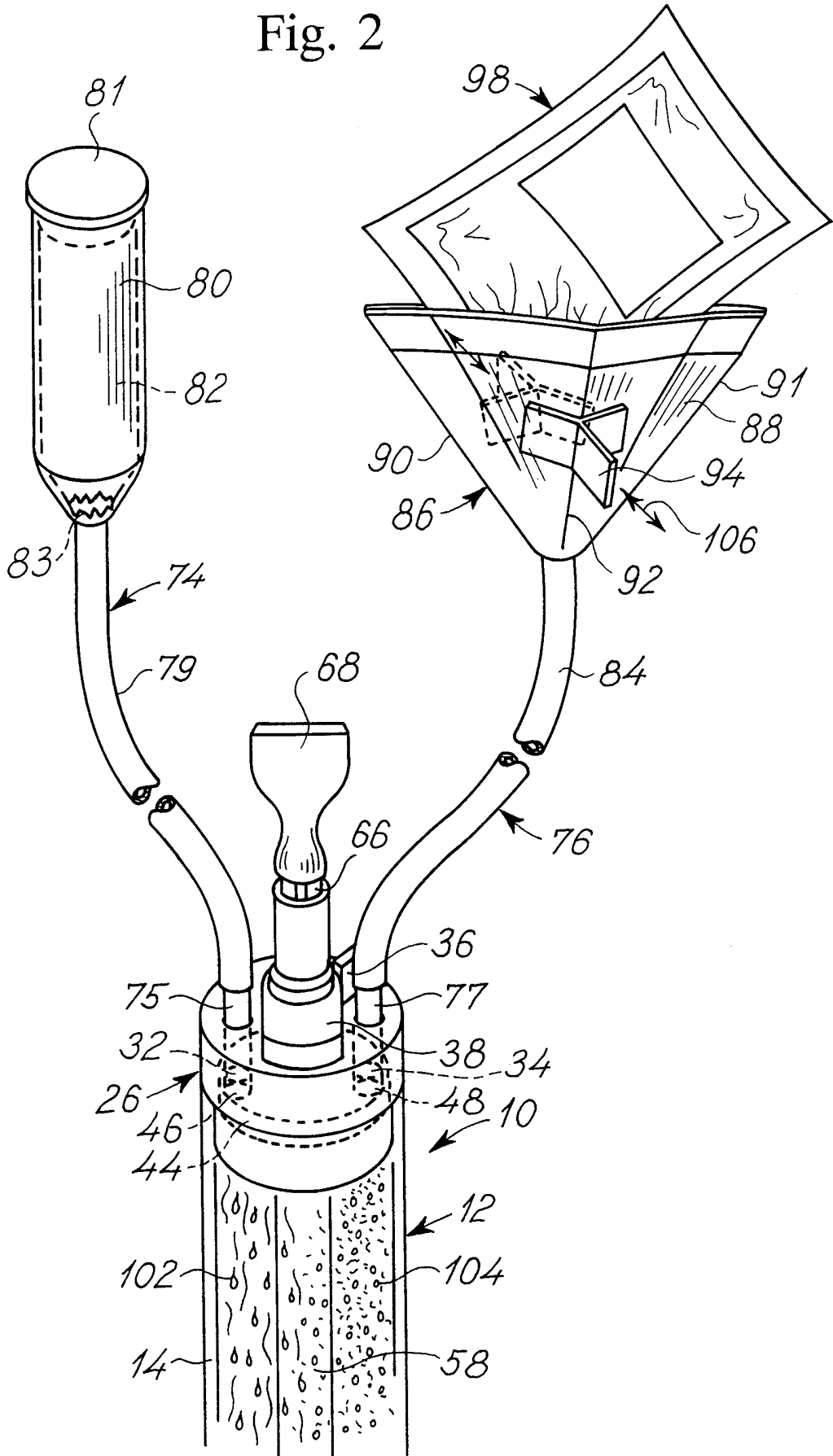

Fig. 3

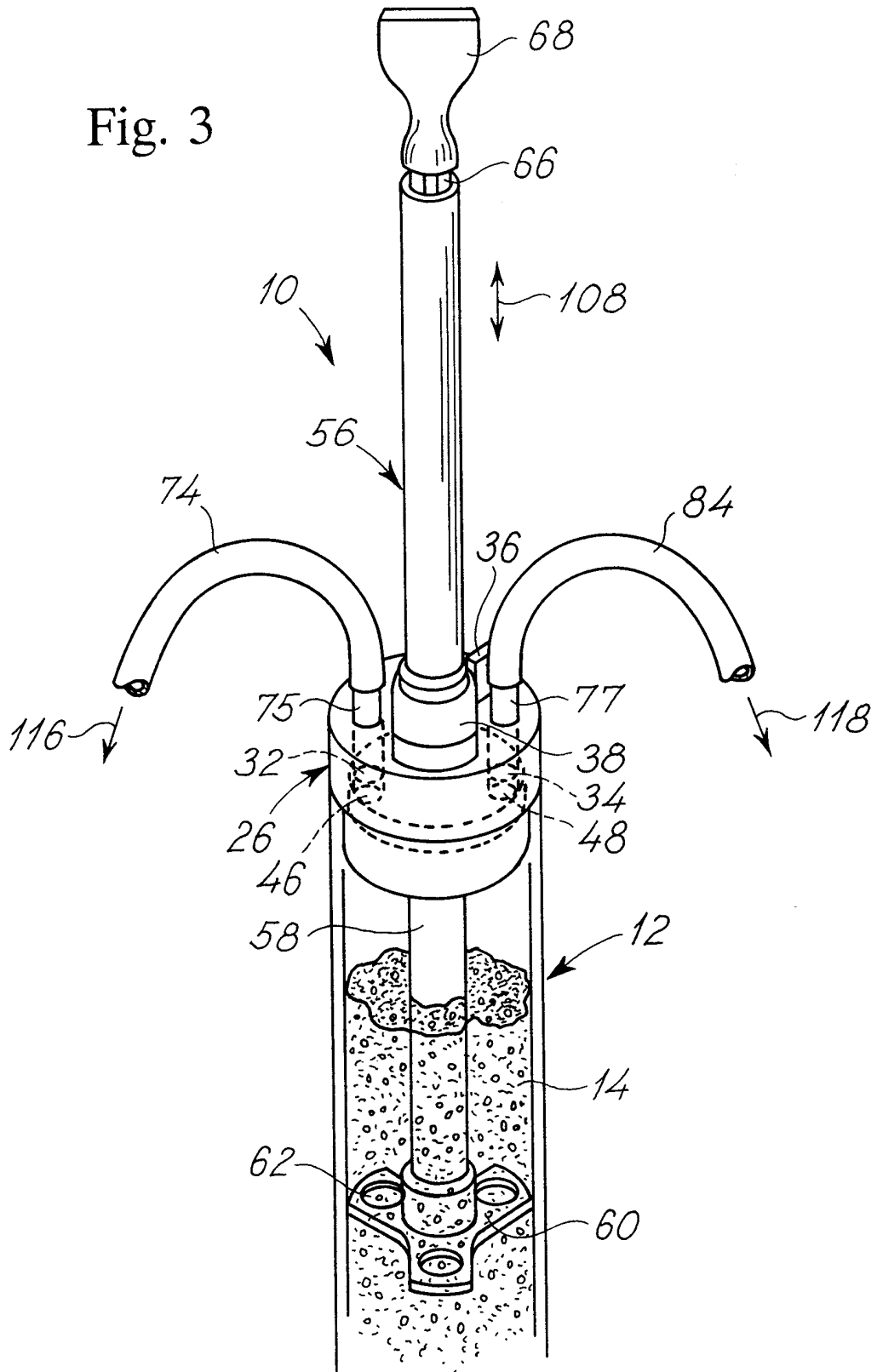

Fig. 7

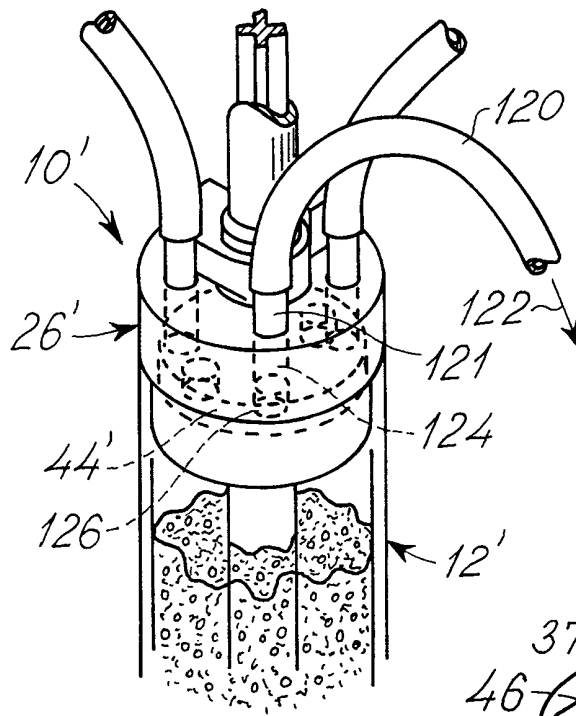

Fig. 4

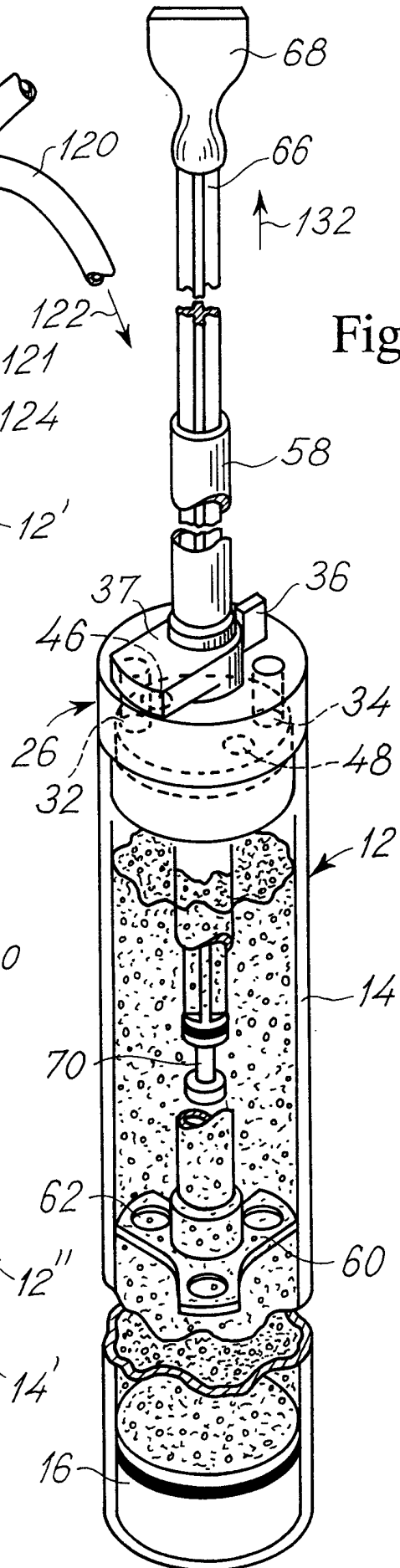
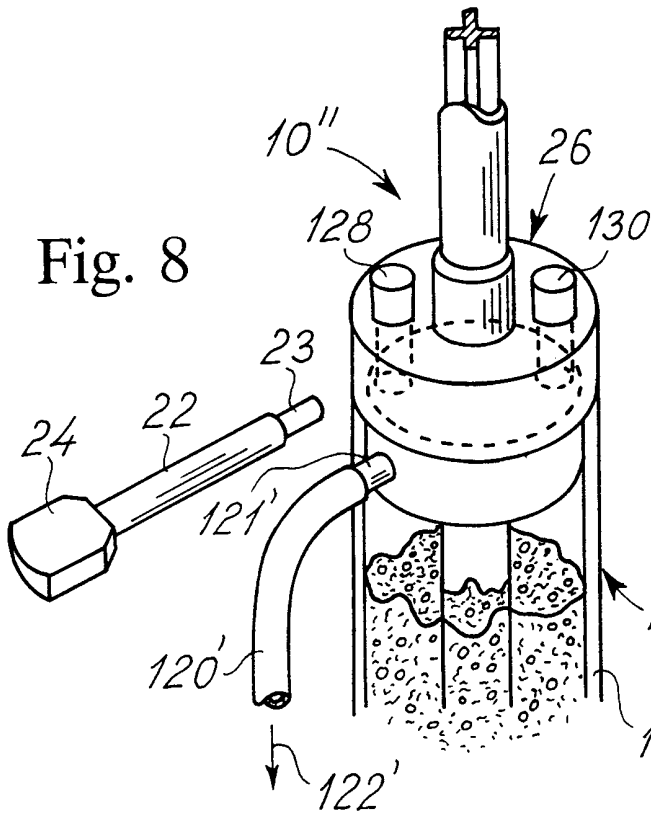
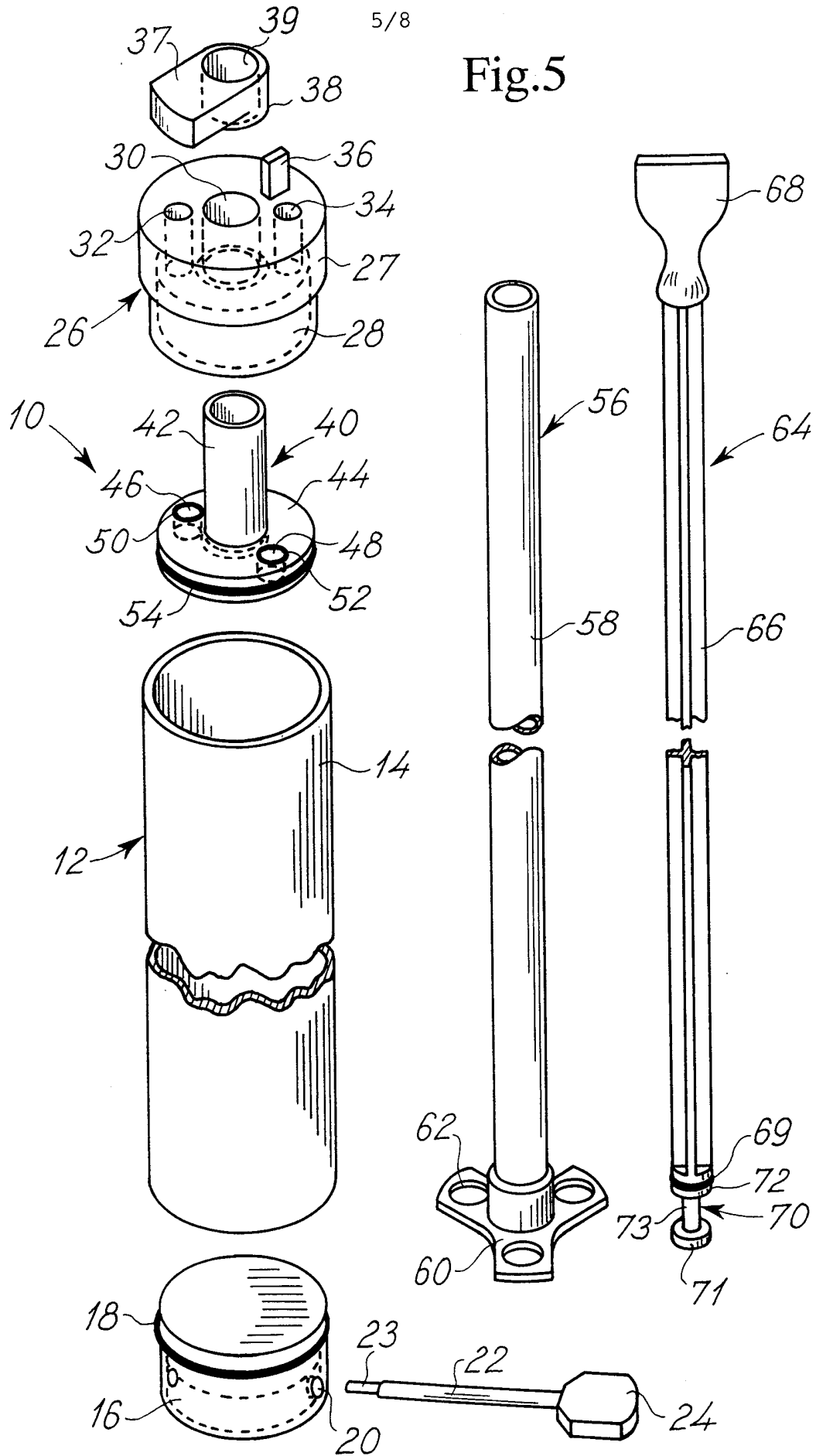

Fig. 8





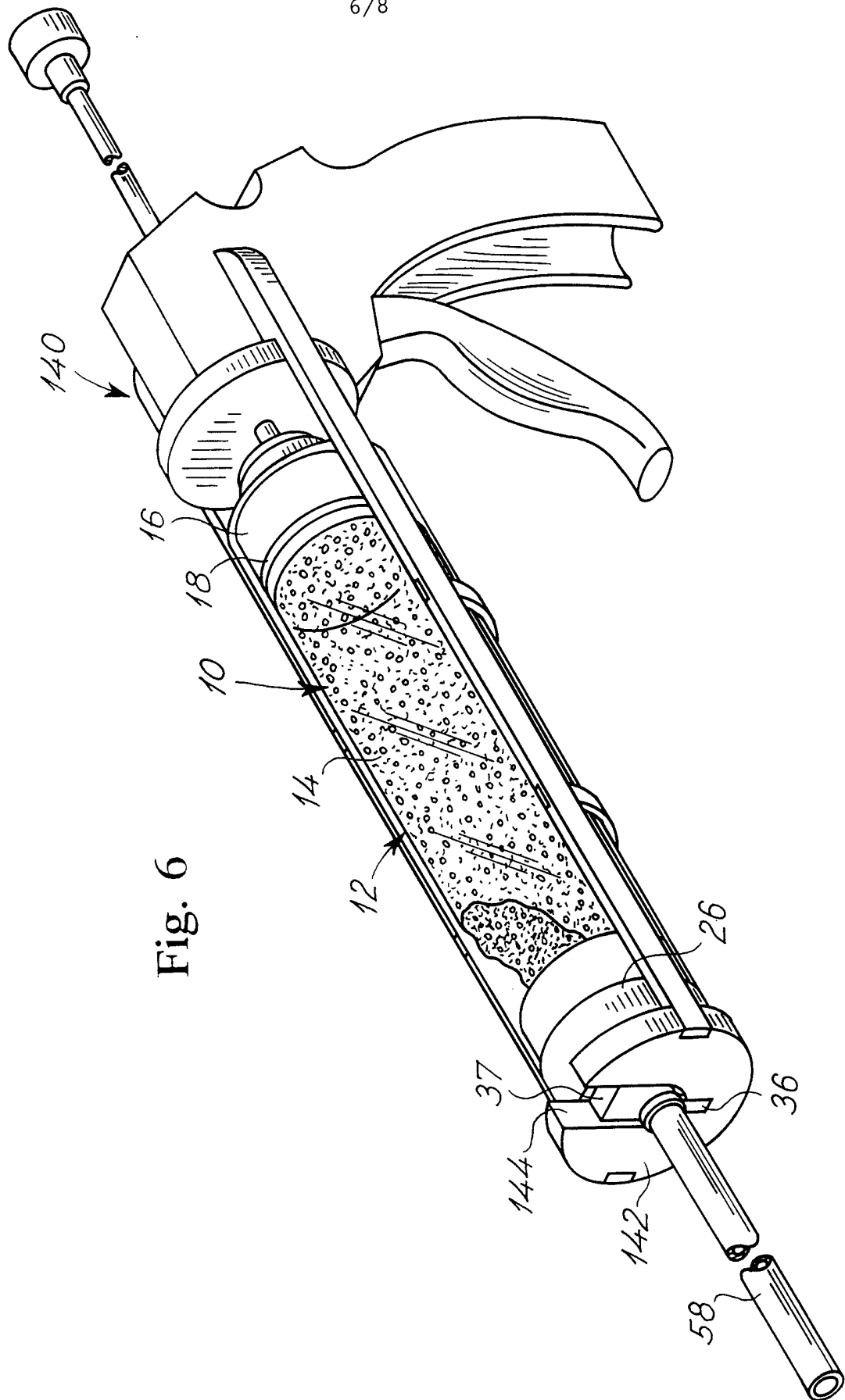

Fig. 6

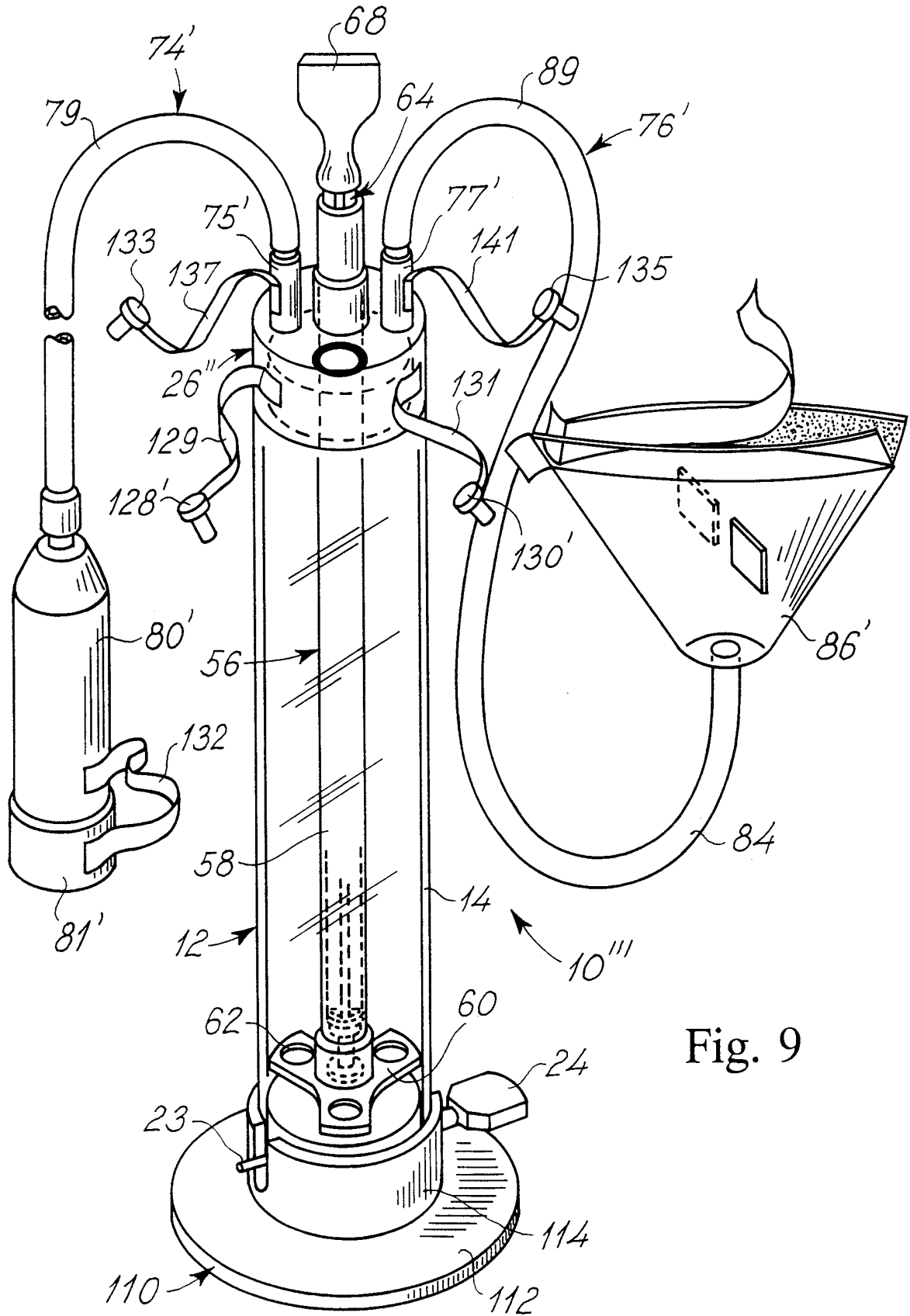

Fig. 9

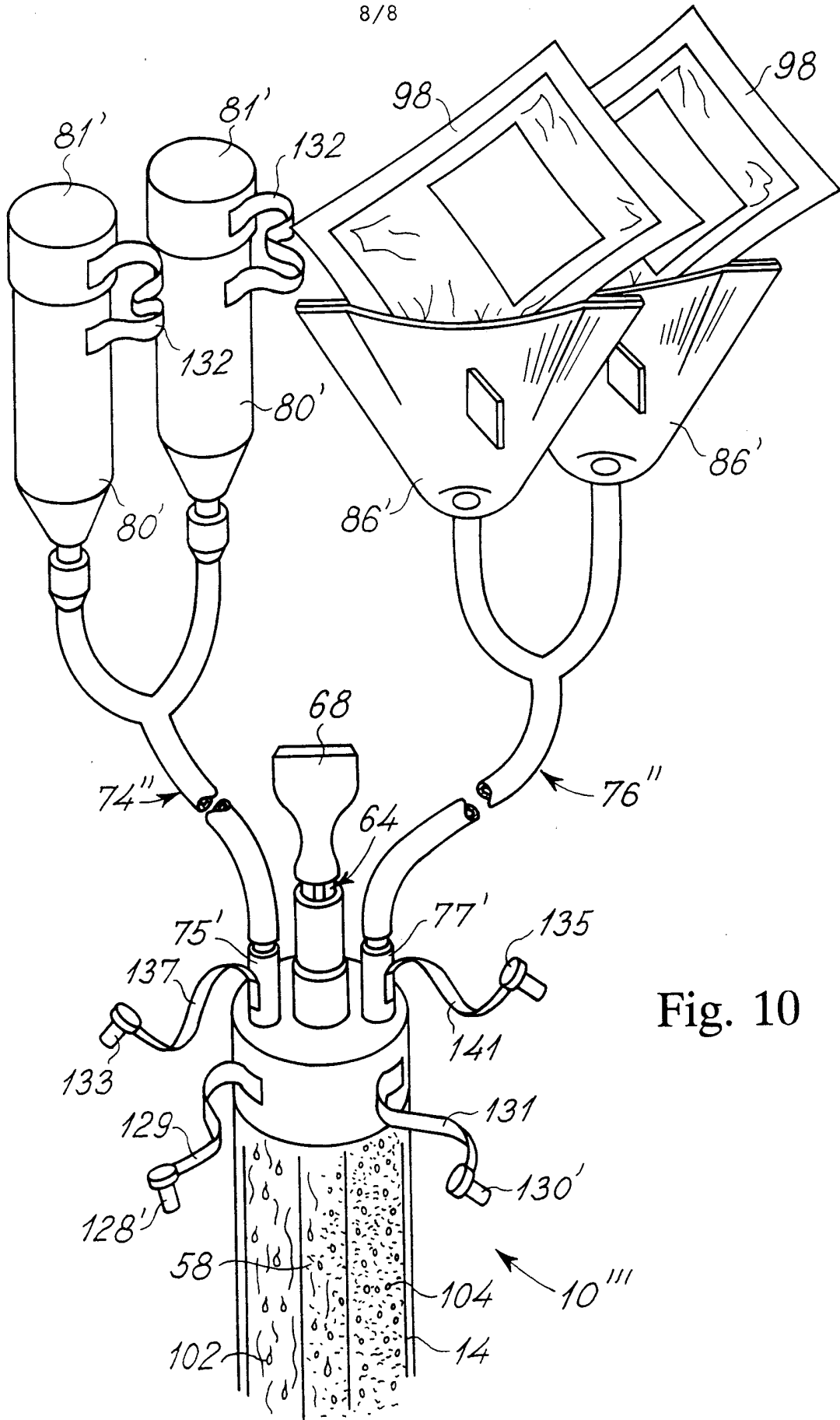

Fig. 10



## INTERNATIONAL SEARCH REPORT

International application No.

PCT/DK 98/00208

## A. CLASSIFICATION OF SUBJECT MATTER

IPC6: B01F 3/12, B01F 13/06, B01F 15/02, A61F 2/46  
According to International Patent Classification (IPC) or to both national classification and IPC

## B. FIELDS SEARCHED

Minimum documentation searched (classification system followed by classification symbols)

IPC6: B01F, A61F

Documentation searched other than minimum documentation to the extent that such documents are included in the fields searched

SE,DK,FI,NO classes as above

Electronic data base consulted during the international search (name of data base and, where practicable, search terms used)

DIALOG: ALLSCIENCE

## C. DOCUMENTS CONSIDERED TO BE RELEVANT

Category*	Citation of document, with indication, where appropriate, of the relevant passages	Relevant to claim No.
A	WO 9500240 A1 (CEMVAC SYSTEM AB), 5 January 1995 (05.01.95)  --	1
A	WO 9426403 A1 (CEMVAC SYSTEM AB), 24 November 1994 (24.11.94)  --	1
A	WO 9322041 A1 (CEMVAC SYSTEM AB), 11 November 1993 (11.11.93)  -- -----	1

Further documents are listed in the continuation of Box C.  See patent family annex.

\* Special categories of cited documents:

"A" document defining the general state of the art which is not considered to be of particular relevance

"E" earlier document but published on or after the international filing date

"L" document which may throw doubts on priority claim(s) or which is cited to establish the publication date of another citation or other special reason (as specified)

"O" document referring to an oral disclosure, use, exhibition or other means

"P" document published prior to the international filing date but later than the priority date claimed

"T" later document published after the international filing date or priority date and not in conflict with the application but cited to understand the principle or theory underlying the invention

"X" document of particular relevance: the claimed invention cannot be considered novel or cannot be considered to involve an inventive step when the document is taken alone

"Y" document of particular relevance: the claimed invention cannot be considered to involve an inventive step when the document is combined with one or more other such documents, such combination being obvious to a person skilled in the art

"&amp;" document member of the same patent family

Date of the actual completion of the international search

18 August 1998

Date of mailing of the international search report

21-08-1998

Name and mailing address of the ISA/

Swedish Patent Office

Box 5055, S-102 42 STOCKHOLM

Facsimile No. +46 8 666 02 86

Authorized officer

Olov Jensén

Telephone No. +46 8 782 25 00

**INTERNATIONAL SEARCH REPORT**  
Information on patent family members

27/07/98

International application No.

PCT/DK 98/00208

Patent document cited in search report			Publication date	Patent family member(s)		Publication date
WO 9500240 A1	05/01/95	AU 7088294 A	17/01/95			
		DE 69405236 D,T	05/03/98			
		EP 0705135 A,B	10/04/96			
		SE 0705135 T3				
-----						
WO 9426403 A1	24/11/94	AU 6763294 A	12/12/94			
		DE 69405579 D,T	26/02/98			
		EP 0725674 A,B	14/08/96			
		SE 500430 C	27/06/94			
-----						
WO 9322041 A1	11/11/93	AU 4274993 A	29/11/93			
		DE 69311582 D,T	08/01/98			
		EP 0726805 A,B	21/08/96			
		SE 0726805 T3				
		SE 470303 B,C	17/01/94			
-----						
SE 9201353 A 30/10/93						