

Feb. 7, 1928.

1,658,459

C. A. NEUBAUER

CIGAR MACHINE

Filed Dec. 8, 1925

4 Sheets—Sheet 1

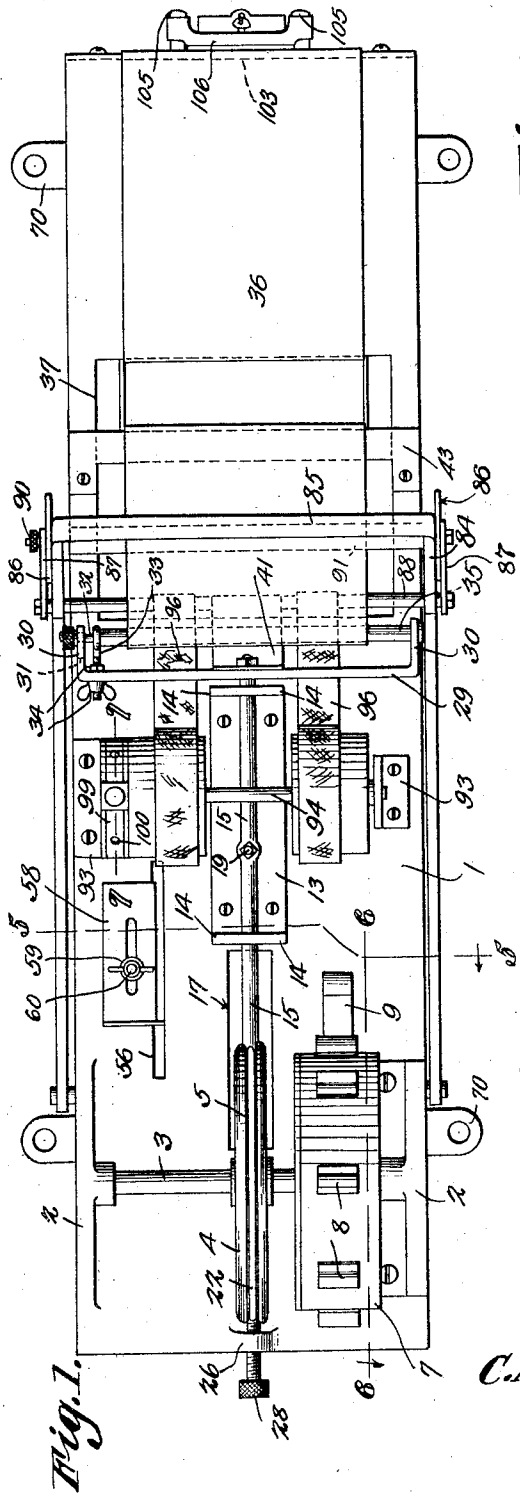

Fig. 10.

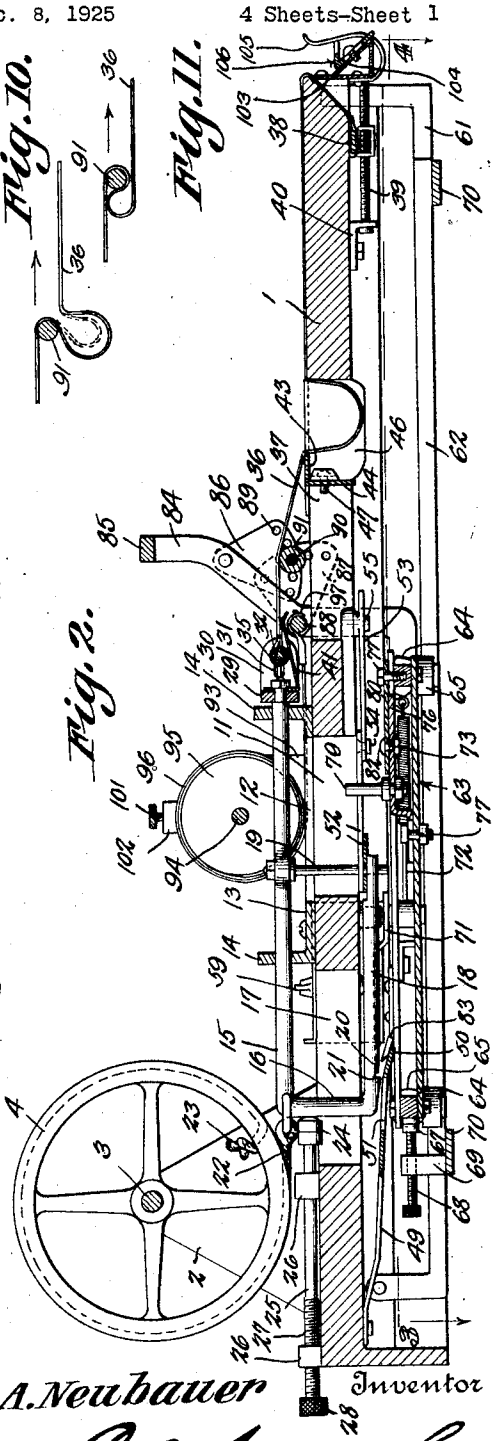

Fig. 11.

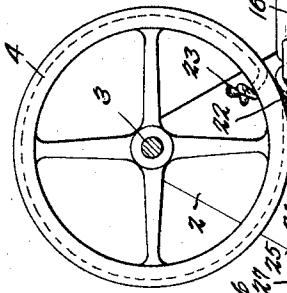

Fig. 2.

C.A. Neubaueer

Inventor

334 C.A. Neubaueer & Co. Attorneys.

Feb. 7, 1928.

1,658,459

C. A. NEUBAUER

CIGAR MACHINE

Filed Dec. 8, 1925

4 Sheets-Sheet 2

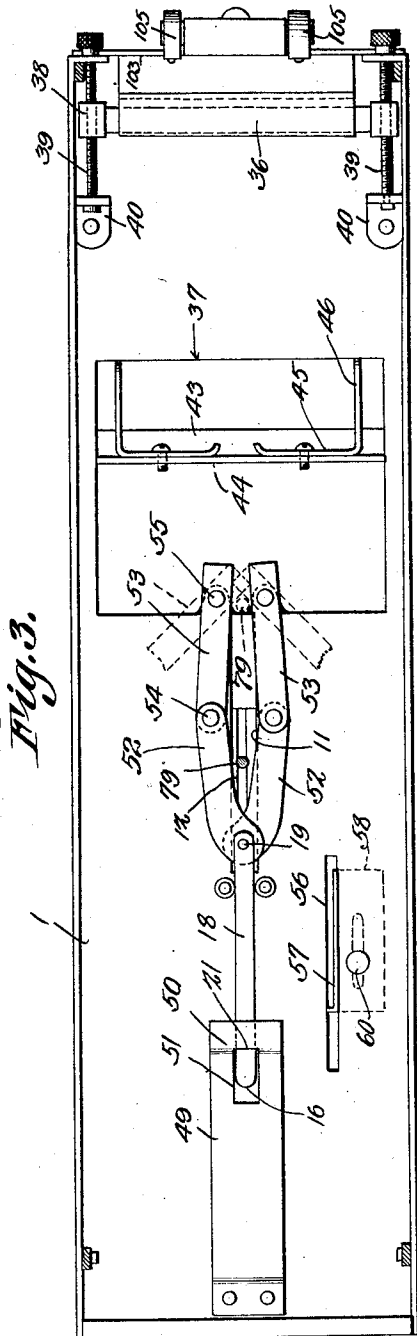

Fig. 3.

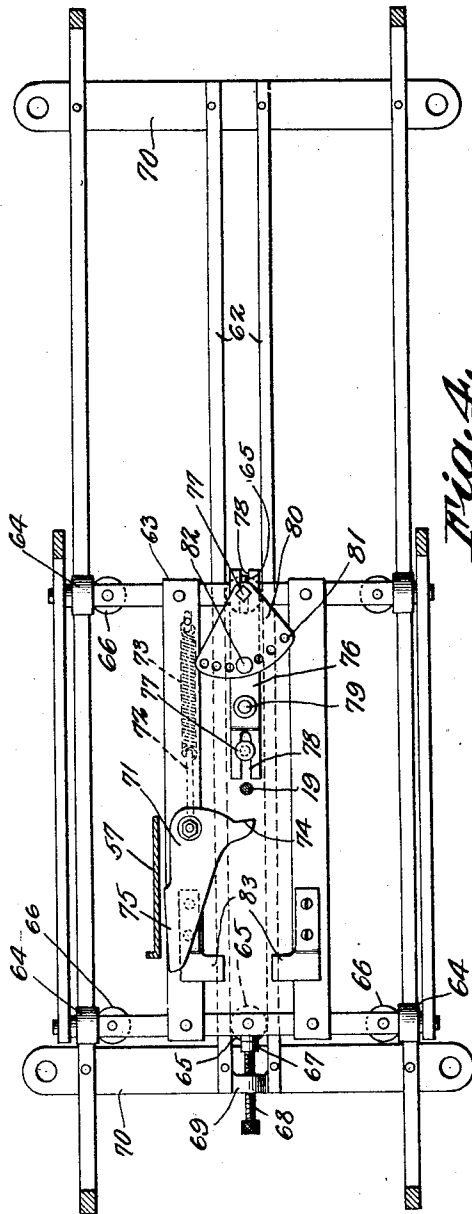

Fig. 4.

C. A. Neubauer

Inventor

By *C. A. Snow & Co.*
Attorneys.

Feb. 7, 1928.

1,658,459

C. A. NEUBAUER

CIGAR MACHINE

Filed Dec. 8, 1925

4 Sheets-Sheet 3

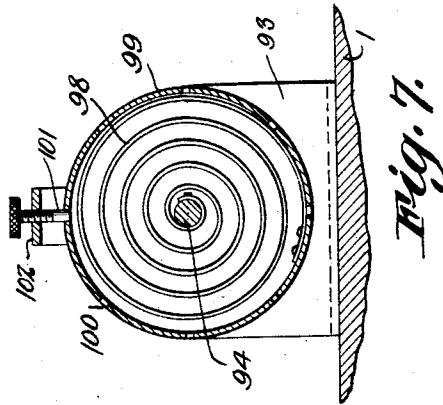
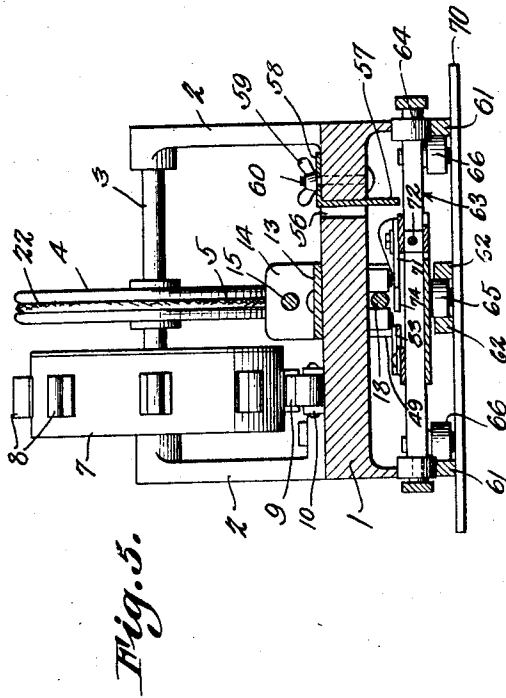
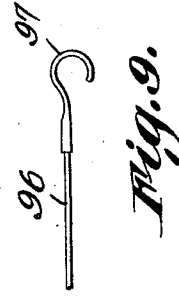
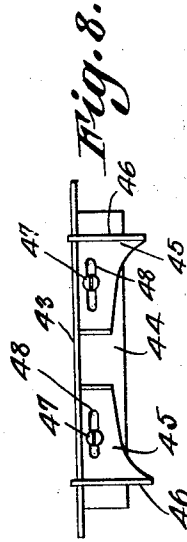
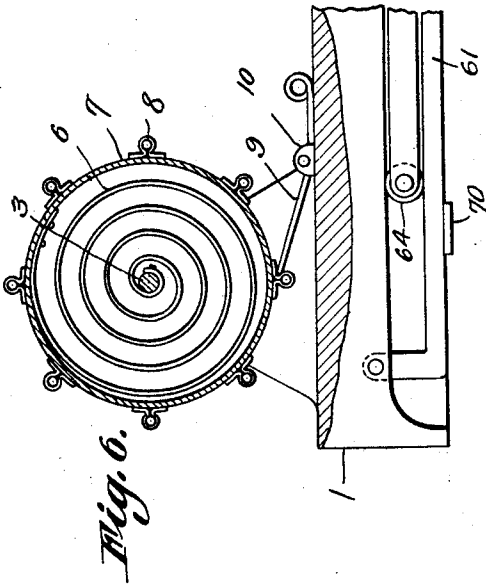

C. A. Neubaer

Inventor

By *C. A. Snow & Co.*
Attorneys.

Feb. 7, 1928.

1,658,459

C. A. NEUBAUER

CIGAR MACHINE

Filed Dec. 8, 1925

4 Sheets-Sheet 4

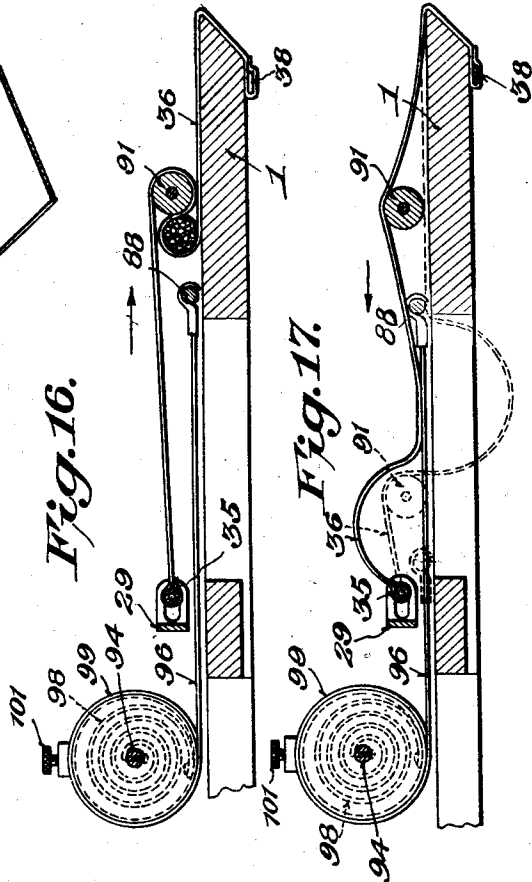
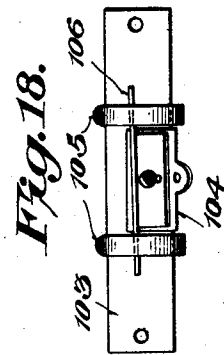
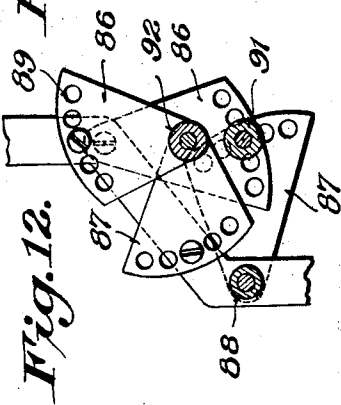
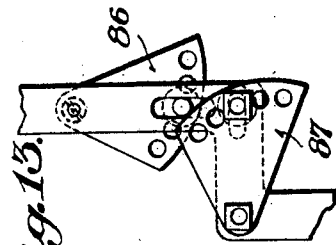
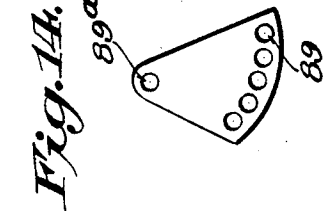
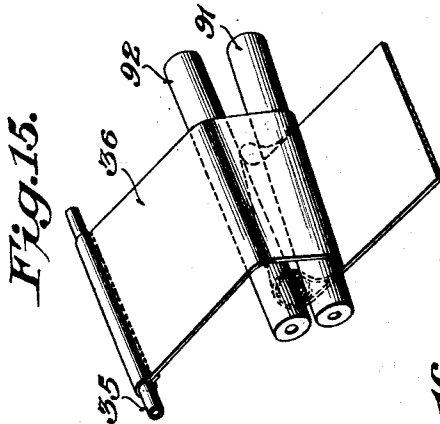

C. A. Neubauer
INVENTOR

UNITED STATES PATENT OFFICE.

CHARLES A. NEUBAUER, OF GLENCOE, MINNESOTA.

CIGAR MACHINE.

Application filed December 8, 1925. Serial No. 74,032.

My invention relates to improvements in cigar machines, and more especially to the type utilizing an apron and a roller to roll the filler into a binder to form a bunch, or roll the filler into a wrapper to form a cigar or stogy when only one wrapping is used, or roll either long or scrap filler into a bunch.

While I am only showing a simple type of an apron, it is to be expressly understood that any flexible means can be used that will answer the purpose, and that all such means is to be included within the term "apron". Also, while I am only showing a simple type of roller that cooperates with the apron to roll a bunch, any other suitable rolling means may be used for said purpose, and all such means are to be understood as included within the term "roller".

One of the objects of my invention is to provide apron-actuating mechanism and roller controlling means that will cooperate to first loosely close the filler pocket formed in the apron, thus forming it into a loose filler loop, then instantly contract the loop to compress the filler therein, hold the actuating and controlling means in their proper positions and release the roller at a predetermined point to finish the rolling operation by means operating in timed relation to effect a smooth and easy operation.

Another object is to provide means for timing and controlling the relative action between the roller and the apron actuating mechanism while the filler loop is being contracted to compress the filler prior to the rolling operation, said means being preferably adjustable for adjusting said timing and controlling means.

Another object is to provide a novel latch mechanism to first actuate, then release, the apron actuating mechanism and simultaneously actuate and release the roller controlling or timing mechanism, said means being preferably adjustable for adjusting the action of said latch mechanism.

Another object is to provide means for locking the apron actuating and roller controlling or timing means after the filler has been compressed for the purpose of holding the tension of the filler loop formed in the apron during the rolling operation, and means for unlocking the locking means after the rolling operation.

Another object is to provide an inertia member that will acquire momentum when actuated by a spring, for the purpose of

aiding said spring in its pull on the apron at the terminating point of the filler compressing operation when the most power is needed.

Another object is to provide novel means for automatically returning the roller carrying mechanism and simultaneously restoring correlated parts to filler-receiving position.

Another object is to provide means for keeping the apron out of the path of the returning roller carrying mechanism during the resetting of parts.

Another object is to provide means for automatically replacing the apron smoothly on the table and forming a filler receiving pocket automatically after each rolling operation.

Another object is to provide novel means for pivotally connecting one end of an apron to the apron actuating mechanism to facilitate its free action.

Another object is to provide an arrangement of antifriction rollers to resist the lateral thrust of the roller carrying mechanism or carriage, while another set of antifriction rollers facilitate its longitudinal movements.

Another object is to provide adjustable buffers to check the return movements of either or both of the apron actuating mechanism and the roller carrying mechanism.

Another object is to provide an adjustable attachment for holding and shaping the pocket formed in the apron to conform to the size and shape of the bunch to be made.

Another object is to provide an adjustable bunch gripper that can be adjusted to snugly grip either straight or tapered bunches of various sizes.

Another object is to provide means for adjusting a roller in any desired angular direction to cooperate with an apron in forming a conical shaped filler loop.

Another object is to provide means for adjusting either or both of a plurality of rollers to angular positions relative to each other to cooperate with an apron in forming a conical shaped filler loop.

Another object is to provide positive adjusting means for adjusting one or more rollers to angular positions.

Another object is to provide an adjustment on one or both ends of an apron to take up slack in either side of said apron when a conical shaped filler loop is desired.

With the foregoing and other objects in view which will appear as the description proceeds, the invention resides in the combination and arrangement of parts and in the details of construction hereinafter described and claimed, it being understood that changes in the precise embodiment of the invention herein disclosed may be made within the scope of what is claimed without departing from the spirit of the invention.

In the accompanying drawings the preferred form of the invention has been shown.

In said drawings,

Figure 1 is a top plan view of the machine, the parts being shown in their normal positions.

Figure 2 is a central vertical longitudinal section therethrough, showing means for mounting a roller, the supplementary roller being omitted.

Figure 3 is a horizontal section taken on the line 3—4 Figure 2 showing the table of the machine in bottom plan.

Figure 4 is a section on line 3—4 Figure 2, looking in the direction of the arrow and showing the carriage in top plan.

Figure 5 is a section on line 5—5 Figure 1.

Figure 6 is a section on line 6—6 Figure 1.

Figure 7 is an enlarged section on line 7—7 Figure 1.

Figure 8 is a front elevation of a gage used for adjusting the size and shape of the filler pocket formed in the apron when scrap filler is used.

Figure 9 is a side elevation of a portion of one of the carriage and apron returning belts.

Figure 10 is a view in diagram showing the relative position of the apron and its supporting roller just prior to the release of the yoke, the contraction of the loop immediately following the release of the yoke being indicated by broken lines.

Figure 11 is a view similar to Figure 10 showing the position of the loop during the operation of rolling the bunch along the table.

Fig. 12 is a sectional elevation showing the relative position of the segmental plates which are adapted to effect positive adjustment of the rollers independently in any angular direction.

Fig. 13 is a sectional view showing the individual adjusting capacity of each segmental plate.

Fig. 14 is a side view of one of the segmental plates used to facilitate positive adjustment for one or more rollers, and also other parts of the machine.

Fig. 15 is a perspective view showing the position of the rollers when adjusted to an angular relation to form a conical shaped filler loop in the apron, as indicated by broken lines, and also showing a sleeve inserted in the hem of the apron.

Fig. 16 is a diagrammatic sectional view showing the filler loop moved in the direction of the arrow during the rolling operation, a belt being also shown as it is unwinding from a drum and following the filler loop to tension the spring shown in dotted lines.

Fig. 17 is a view of the same parts shown in Fig. 16 after the rolling operation, showing the belt being wound back on the drum by the action of the spring, for the purpose of automatically returning the roller, and also in the act of properly positioning the apron for the next rolling operation by frictional contact.

Fig. 18 is a front elevation of the adjustable bunch gripper.

Referring to the figures by characters of reference 1 designates a table provided, adjacent rear end, with standards 2 in which is journaled a shaft 3. Secured to this shaft so as to rotate therewith is a wheel 4 provided with an annular groove 5 in its periphery. To this shaft is secured one end of a spiral coil spring 6 the other end of which is attached to a cylindrical housing 7 rotatably mounted relative to the shaft 3. Ribs 8 of any suitable construction are provided on the periphery of the housing and extend transversely thereof, and any one of these ribs is adapted to be engaged by a dog 9 which is fulcrumed in a bracket 10 on the table 1. The housing is adapted to be rotated so as to place the spring 6 under tension whereupon, by positioning dog 9 in engagement with one of the ribs 8, the housing will be held against rotation by the spring.

A longitudinal slot 11 is formed in the table and registers with a longitudinal slot 12 formed in a plate 13 which is disposed longitudinally on and secured to the table. This plate has upstanding terminal ears 14 constituting bearings for a rod 15. One end portion of this rod is downturned, as at 16, and is designed to reciprocate within a longitudinal slot 17 formed in the table 1. This downturned portion merges into an arm 18 supported beneath the table and parallel with the rod 15 and extended forwardly under the slot 11. A pin 19 connects the forward end of the arm 18 to the rod 15 and is adapted to reciprocate within the slots 11 and 12. A notch 20 is formed in the arm 18 near the rear end thereof and provides a shoulder 21 for the purpose hereinafter explained. A cord 22 is secured to the rod 15 close to the depending portion 16 and is normally extended around the wheel 4, this cord being seated in the groove 5 and having one end fastened to the wheel as shown at 23. For the purpose of checking the rearward movement of the rod 15, a buffer is provided in the form of a suitable cushion 24 mounted on a rod 25 which is provided with a thread 27 and a head 28. This rod is mount-

ed in ears 26, one of which is provided with threads to engage the threaded portion of the rod 25. Obviously, by turning the head 28 the cushion 24 can be adjusted forwardly or backwardly to stop the rod 15 at the desired point when it is returned by the action of the spring 6 and wheel 4 through cord 22.

The forward end of the rod 15 is attached to a yoke 29 extending transversely of the table and provided with forwardly extending arms 30 one of which has a longitudinal slot 31. This slot receives one end of a rod 32 the other end of which is fastened within the other arm 30 of the yoke. The rod is held adjustably in the slot 31 by an eye bolt 33 through which the rod extends. This eye bolt is adjustably connected to the yoke by nuts 34 as shown particularly in Figure 1. Obviously by adjusting the eye bolt the rod can be shifted within the slot 31 so that said rod can thus be disposed at any desired angle relative to the yoke to take up or let out slack on the preferred side of the apron.

Loosely mounted on the rod 32 is a sleeve 35 about which is fastened one end of an apron 36. This apron is extended longitudinally over a front portion of the table and hangs into an opening 37 formed in the table, thus forming a filler receiving pocket. The forward end of the apron is extended downwardly over the forward end of the table and is attached to a cross strip 38 the ends of which are mounted on adjusting screws 39 carried by suitable supporting brackets 40. Obviously by rotating these screws the strip 38 can be shifted longitudinally of the screws, thereby to take up slack in the apron or pay out the apron, as preferred.

A supporting plate 41 is connected to the middle portion of the yoke 29 and is designed to bear upwardly against the apron as shown particularly in Figure 2 for the purpose of preventing the apron from crumpling beneath the yoke.

For the purpose of adjusting the size and shape of the pocket formed in the apron when scrap filler is used, a cross strip 43 is extended under the apron 36 and across the opening 37 in table 1. By setting this strip 43 forward, the depth and width of the pocket is decreased; by setting one end of this strip forward, the pocket is gradually decreased toward the forward end of the strip. This strip is provided with a depending flange 44. Wings 45 extending inwardly from side plates 46 are secured to the flange 44 by bolts 47 extending through slots 48 within the wings 45. Thus it will be seen that the plates 46 can be adjusted toward or from each other according to the width of that portion of the apron that forms the filler pocket, so as to prevent the scraps from falling out of the ends of the pocket. The longitudinal length of the

guard plates can be varied so as to indicate the position the cross strip 43 should occupy to reduce the size of the pocket. If the cigar is to be tapered, one of the guard plates can be shorter than the other, to determine the diagonal position in which the cross strip 43 should be placed to shape the pocket. If the cigar is to be drawn in at the tuck end also, the guard plates 46 are adjusted toward each other so as to make the pocket shorter than the cigars to be made; enough scraps will be displaced in the rolling operation to form a desirable drawn-in tuck; thus both ends of the cigar will be tapered. The portion of the apron that forms the pocket is cut to fit in between the guard plates 46.

A spring tongue 49 is attached to the bottom of the table 1 and has its forward or free end downturned as indicated at 50, there being a slot 51 within the tongue. This tongue is so positioned that, when the arm 18 is pulled back at a certain period during the filler compressing operation of the machine, the shoulder 21 in the arm 18 will be seated in the slot 51 so that the forward wall of the slot will hold arm 18 against forward movement, thus preventing the compressed filler from expanding.

The pin 19 carried by arm 18 and rod 15 constitutes the fulcrum of one pair of links 52 of a toggle. The links 53 are levers controlled by this toggle and are pivotally connected to the links 52 as shown at 54 and are also pivotally connected to the bottom of the table 1 as shown at 55. When the rod 15 is in its normal position the links 52 and 53 are located as shown in Figure 3 so that the lever links 53 are about parallel. However when the rod 15 is moved toward the front end of the table, the links of the toggle will be shifted with the result that the forward ends of the lever links 53 will be swung toward each other into lapped relation. This relative position of the parts has been indicated by broken lines in Figure 3.

Formed in one side portion of the top of the table 1 is a longitudinal slot 56 through which extends a restraining flange 57 depending from a longitudinally slotted plate 58 mounted on the table 1. A clamping nut 59 engages a stud 60 extending through the slot in this plate and by tightening the same the plate can be held in any position to which it might be adjusted longitudinally of the slot 56.

Arranged under and parallel with the side portions of the table 1 are guide rails 61 and below the center of the table is a pair of longitudinal guide rails 62. A roller carrying mechanism, referred to as a carriage, is indicated generally at 63 and is adapted to travel back and forth beneath the table. This carriage is provided with antifriction rollers 64 mounted so as to travel between the bot-

tom side edges of the table and the top faces of the rails 61, thus facilitating the reciprocatory movement of the carriage. Another set of two or more antifriction rollers is mounted on the bottom sides of the axletrees of the carriage so as to travel either between the rails 62, as shown at 65, or along the inner sides of the rails 61 as shown at 66, and are set at a 90° angle relative to the rollers 64, for the purpose of resisting the lateral thrust of the carriage. Thus it will be seen that the carriage will be held in proper position and free and easy reciprocating movements thereof are insured. For the purpose of adjustably limiting the rearward movement of the carriage, a buffer in the form of a suitable cushion 67 is mounted on a screw 68 which is arranged within an ear 69 extending upwardly from a cross bar 70 which constitutes a connection between the rails 61 and 62.

A latch 71 is pivotally mounted on the carriage and has a finger 72 connected thereto and adapted to move therewith. A spring 73 connects this finger to the front portion of the carriage. Extending laterally from the latch is a nose 74 adapted to come against and thrust the lower end portion of the pin 19, the parts being held in engagement during the first portion of the forward movement of the carriage by reason of the contact of the tail portion 75 of the latch with the restraining plate 57.

A strip 76 is slidably mounted on the carriage, it being held in proper position by guide studs 77 extending through slots 78 formed in the ends of the strip 76. This strip 76 carries a timer pin 79 which normally projects between the links 52. The position of the timer pin 79 relative to the end of the carriage 63 can be adjusted by means of a segmental plate 80 pivotally mounted on one of the studs 77 and having a series of apertures 81 eccentrically disposed relative to the stud on which the plate 80 is pivoted. A bolt 82 can be extended through any one of the apertures 81 and into engagement with the strip 76. Thus it will be seen that pin 79 can be adjusted toward or from the studs 77 and a very fine adjustment can be obtained.

Deflecting ears 83 are connected to the carriage and are so located as to extend over and depress the free end portion of the tongue 49 as shown particularly in Figure 2.

The carriage 63 is provided with an upstanding frame 84 located beyond the sides of the table 1 and provided with a cross bar handle 85 adapted to be grasped by the operator to actuate the carriage. To one or both sides of this upstanding frame are pivotally connected any desired number of segmental plates 86 and 87, to facilitate positive adjustment for a roller 91 and a roller 92, if used. The plates that regulate the

roller 91 are located on the outward sides of the frame 84 and the plates that regulate the roller 92, if used, are located on the inward sides of the frame 84. Fig. 12 shows one way of applying the plates to one or both ends of either roller. The plates 86 are placed in a position that tends to regulate the roller which they control in an up and down direction, and the plates 87 are placed in a position that tends to regulate the roller they control in a horizontal direction. Fig. 13 shows the individual adjusting capacity of the plates when one of the plates 87 is mounted so as to regulate the roller 91 and one of the plates 86 is mounted so as to regulate the roller 92, similar to the mounting of the segmental plate 80 shown in Fig. 4. However, when the plates 86 and 87 are used conjunctively on the end of one roller, as shown in Fig. 2, they facilitate the adjustment of that roller in every desired angular direction, which is desirable in the production of a tapered cigar, as it effects the formation of a conical shaped filler loop in the apron and prevents it from wrinkling during the production of a tapered cigar. By providing two plates 86 and 87 at both ends of a roller, as shown in Fig. 1, a greater capacity for adjustment is provided, and when two rollers are used, either one or both ends of each or both may be adjustably mounted as shown in Fig. 12, whereby the extent of adjustment and the flexibility of use is greatly increased, this being desirable in the production of large cigars having considerable taper. Either end of either of the shafts carrying either of the rollers 91 or 92 can also be mounted in a manner similar to that shown in Fig. 13, if desired. The segmental plates have a series of apertures 89 diversely located to an aperture 89^a, and any of the apertures in one plate is adapted to be moved in register with any one of the apertures in the other plate to receive one end of a shaft, as shown in Fig. 12. A shaft 90 carries the roller 91 on which the apron rests when only one roller is used, as shown in Figs. 2 and 16. When the roller 92 is used the apron 36 is extended thereover and rests thereon instead of resting on the roller 91, as shown in Fig. 15.

For the purpose of automatically forming a filler pocket in the apron and replacing it smoothly on the table, returning the carriage, and guarding the apron to keep it out of its path after the rolling operation, brackets 93 are mounted on the table 1 near the sides thereof. In these brackets is journaled a shaft 94 provided with a pair of drums 95 rotatable with the shaft. Secured to each of these drums is one end of a belt 96, the other end of each belt being provided with a hook 97 adapted to engage the rod or shaft 88. A spring 98 is disposed within a

housing 99 mounted for rotation relative to the shaft 94 and one end of this spring is secured to the shaft 94 while the other end is secured to the housing. This housing may be provided with apertures 100 any one of which is adapted to receive a holding screw 101 carried by an extension 102 of the adjacent bracket 93. Thus the spring 98 can be placed under any desired tension and will act to hold the belts 96 normally wrapped around the drums 95, and will yield to the unwinding of the belts 96 as the carriage 63 moves forward and draws the belts 96, so that an unwound portion of said belts will travel adjacent to the bottom side of that portion of the apron 36 which remains behind the filler loop during the rolling operation, as shown in Fig. 16. Consequently, after the rolling operation, the belts will be wound back on the drums by the action of the spring, thus drawing the carriage back. The apron will then rest on the rearwardly moving belts 96 which will support and guard the apron out of the path of the returning carriage, and the frictional contact of the belts with the bottom side of the apron will pull the apron back smoothly over the table, as shown in Fig. 17, and then allow a rear end portion of it to drop into the opening 37 and automatically form a filler receiving pocket immediately after the roller has been returned to normal position as shown in dotted lines in Fig. 17.

For the purpose of gripping each bunch after it is rolled, a gripper is mounted at the front end of the table, this being shown particularly in Figures 1, 2 and 18. This gripper includes an attaching plate 103 having an inclined portion 104. Gripping springs 105 are connected to the plate and form open loops for receiving a bunch. A spreading plate 106 is adjustably mounted on the inclined portion 104 of the attaching plate and by lowering this plate 106 it can be caused to bear against springs 105 so as to enlarge the bunch receiving space both as to depth and width in the gripper. By raising the plate 106 the springs 105 will contract and thereby reduce the bunch receiving space both as to depth and width. By adjusting the plate 106 to a diagonal position, as shown in Fig. 18, the bunch receiving space will be deeper and wider at one spring than at the other. Thus the gripper can be adjusted to snugly grip bunches of various sizes and shapes.

In operation, the apron 36 and roller 91, or roller 92, if used, are first adjusted to form a loop of the proper size and shape to conform to the style of cigar to be made, and the other parts are also adjusted as already explained.

The various parts are normally located as shown in Figs. 1 and 2, which omit the roller 92, for sake of clearness, although it is to

be understood that both rollers may be used when desired, both rollers being shown, with their adjustable mountings, in Figs. 12 and 13.

A portion of the apron 36 hangs within the opening 37 and forms a pocket which is reduced in size both as to the depth and width of it by the cross strip 43 of the pocket gage, the ends of the pocket being closed by the guard plates 46 of the gage, as shown in Fig. 2. When long filler is used, the gage is removed and obviously a larger portion of the apron will drop into the opening 37 and a larger filler pocket is formed, as shown by the dotted lines in Fig. 17. To make a long filler bunch, a binder is laid upon that portion of the apron 36 which rests on table 1 with a small portion of said binder extending into the pocket formed in the apron. The filler is then placed into the pocket, and the bar handle 85 is pulled forwardly to draw the roller carrying mechanism or carriage 63 forward, causing the nose 74 of the latch 71, which is pivotally and resiliently mounted on said carriage, to come against the lower end of the pin 19, and the tail portion 75 to contact the restraining plate 57. Thus the pin 19, arm 18, rod 15, yoke 29 and the rear end of the apron 36 are brought forward a short adjustable distance until the top of the pocket is almost closed or converted into a loose filler loop, as shown in Fig. 10. This forward movement of pin 19 has also caused the wheel 4 to rotate in the direction to place the spring 6 under increased tension and has caused the toggle made up of links 52 to spread at the joints 54 until the free ends of the lever links 53 are swung to a lapped position crossing the path of the timer pin 79, as shown by the broken lines in Fig. 3. At this point the tail 75 of the latch 71 slides off of the restraining plate 57 and releases pin 19, with the result that the spring 6 will set the wheel 4 into a quick rotary motion to exert a pull on the apron to contract the filler loop, through cord 22, as shown by the dotted lines in Fig. 10. The wheel 4 is calculated to be of the specific size and weight required as an inertia member to gain sufficient speed and momentum while the filler loop is slack and little power is needed, so that it will adequately aid the spring 6 to overcome the greater resistance of the filler at the terminating point of the filler compressing operation when the most power is required and the spring has the least power. Thus a smooth and easy operation is effected.

At the point when the pin 19 is released, the timer pin 79 which is mounted on the carriage will have been moved to a position very near the lapping ends of the lever links 53, as shown in Fig. 3, and consequently the roller will be retarded in its forward move-

ment until the spring 6 has pulled the toggle and lever links back to their normal or parallel positions. The pressure of the timer pin 79 against the lapping ends of the lever links 53 will help to force the pin 19 back, and thus aid the spring 6 in pulling the arm 18, rod 15, yoke 29 and the rear end of the apron back to contract the filler loop for compressing the filler. Thus the action of the roller is timed and controlled conjunctively with the action of the spring 6 and wheel 4 during the filler compressing operation. When the arm 18 has been brought back to its normal position, the shoulder 21 on the arm 18 is caught in the slot 51 of the spring tongue 49 and held there in a locked position, thus preventing the rebound or forward movement of the yoke 29 which carries the rear end of the apron 36. Thus the filler loop remains in its contracted condition and the filler also remains in the exact compressed condition desired throughout the rolling operation. The timer pin 79 is released the instant the filler is compressed, thus permitting the roller to freely continue its forward movement to finish the rolling operation, as shown in Fig. 16. The bunch is then automatically deposited into the bunch gripper attached to the front end of the table 1, this gripper being adjustable to snugly grip bunches of various sizes and shapes to prevent the bunch from loosening.

The carriage is then automatically returned, as previously explained, by the action of the spring 98 when in the act of winding the belts 96 back on the drums 95. The belts 96 not only serve to return the carriage, but also support the apron out of the path of the carriage as it is being returned, and their frictional contact with the bottom side of the apron will pull the apron back smoothly over the table and allow a portion of it to drop into the opening 37, thus automatically forming a pocket therein. The loose sleeve 35, inserted in the hem of the apron, facilitates its free action in forming the pocket.

As the carriage approaches its rearmost position, the deflecting ears 83 mounted on said carriage ride onto the inclined end portion 50 of the tongue 49 and depress the tongue so as to disengage it from the shoulder 21 of the arm 18, as shown in Fig. 2.

What is claimed is:

1. In a bunching machine, in combination with relatively movable members for rolling a bunch, a member adapted to be moved with one of the relatively movable members for a portion of its movement, means whereby said last-named member is moved in the opposite direction to compress the filler, and means movable with the aforesaid relatively movable member for first enforcing movement of said second-named member therewith and then releasing said member to the action of said means for compressing the

filler, said second named means including a device for retarding the movement of said relatively movable member as said filler-compressing means comes into operation.

2. In a bunching machine, in combination with relatively movable members for rolling a bunch, a member adapted to be moved with one of the relatively movable members for a portion of its movement, means whereby said last-named member is moved in the opposite direction to compress the filler, means movable with the aforesaid relatively movable member for first enforcing movement of said second-named member therewith and then releasing said member to the action of said means for compressing the filler, timing means operated by the movement of the aforesaid relatively movable member, and means movable with said last-named member and cooperating with said timing means for timing the movement of said member during the action of said filler-compressing means.

3. In a bunching machine, in combination with relatively movable members for rolling a bunch, a member adapted to be moved with one of the relatively movable members for a portion of its movement, means whereby said last-named member is moved in the opposite direction to compress the filler, and means movable with the aforesaid relatively movable member for first enforcing movement of said second-named member therewith and then releasing said member to the action of said means for compressing the filler, said second-named means including an element movable with the aforesaid relatively movable member and means operated by said last-named movable member and cooperating with said element to first retard and then release said element.

4. In a bunching machine, in combination with relatively movable members for rolling a bunch, a member adapted to be moved with one of the relatively movable members for a portion of its movement, means whereby said last-named member is moved in the opposite direction to compress the filler, and means movable with the aforesaid relatively movable member for first enforcing movement of said second-named member therewith and then releasing said member to the action of said means for compressing the filler, said second-named means including an element movable with the aforesaid relatively movable member, and levers cooperating with said element to retard said element, said levers being operatively connected with said second-named member, whereby said element imparts a reverse movement to said second-named member as it passes said levers.

5. In a bunching machine, in combination with relatively movable members for rolling a bunch, a member adapted to be moved

with one of the relatively movable members for a portion of its movement, means whereby said last-named member is moved in the opposite direction to compress the filler, means movable with the aforesaid relatively movable member for first enforcing movement of said second-named member therewith and then releasing said member to the action of said means for compressing the filler, an element movable with the aforesaid relatively movable member, and timing means operatively connected to said second member and moved by the movement of the aforesaid relatively movable member, said timing means cooperating with said element to retard the movement of said last named movable member and being operated by said second member under the action of said filler-compressing means to permit free passage of said element.

6. In a bunching machine, in combination with relatively movable members for rolling a bunch, a member adapted to move with one of the relatively movable members for a portion of its movement and to move in the opposite direction for compressing the filler, means for actuating said second member, an element movable with the aforesaid relatively movable member, timing means operatively connected with said second member, and means movable with the aforesaid relatively movable member for moving said second member and operating said timing means.

7. In a bunching machine, in combination with relatively movable members for rolling a bunch, a member adapted to move with one of the relatively movable members for a portion of its movement and to move in the opposite direction for compressing the filler, means for actuating said second member, an element movable with the aforesaid relatively movable member, timing means operatively connected with said second member, and means movable with the aforesaid relatively movable member for moving said second member and operating said timing means, said timing means cooperating with said element to retard the movement of the aforesaid relatively movable member and said element cooperating with said timing means to actuate said second member in the direction for compressing the filler.

8. In a bunching machine, in combination with an apron and a movable roller for rolling the bunch, a member connected to said apron and adapted to move with the roller for a portion of its movement, means for moving said member in the reverse direction for compressing the filler, and means for first enforcing movement of said member with said roller and then releasing the same to the action of said last-named means, said means including a latch movable with the roller, an element connected to said

member and cooperating with said latch, and means for first maintaining said latch in cooperative engagement with said element and then releasing said latch.

9. In a bunching machine, in combination with an apron and a movable roller for rolling the bunch, a member connected to said apron and adapted to move with the roller for a portion of its movement, means for moving said member in the reverse direction for compressing the filler, and means for first enforcing movement of said member with said roller and then releasing the same to the action of said last-named means, said means including an element movable with the roller and timing means operated by the movement of said member and cooperating with said element to retard the movement of said roller at a predetermined point in its movement.

10. In a bunching machine, in combination with an apron and a movable roller for rolling the bunch, a member connected to said apron and adapted to move with the roller for a portion of its movement, means for moving said member in the reverse direction for compressing the filler, and means for first enforcing movement of said member with said roller and then releasing the same to the action of said last-named means, said means including an element movable with the roller, timing means cooperating with said element and operatively connected to said member, and means movable with said roller for operating said timing means to first retard and then release said element.

11. In a bunching machine, in combination with an apron and a movable roller for rolling the bunch, a member connected to said apron and adapted to move with the roller for a portion of its movement, means for moving said member in the reverse direction for compressing the filler, and means for first enforcing movement of said member with said roller and then releasing the same to the action of said last-named means, said means including an element movable with the roller, timing means cooperating with said element, and operatively connected to said member, and means movable with said roller for operating said timing means to retard the movement of said element, said member on its reverse stroke operating said timing means to permit free passage of said element.

12. In a bunching machine, in combination with an apron and a movable roller for rolling the bunch, a member connected to said apron and adapted to move with the roller for a portion of its movement, means for moving said member in the reverse direction for compressing the filler, and means for first enforcing movement of said member with said roller and then releasing the same to the action of said last-named means,

said means including an element movable with the roller, timing means cooperating with said element and operatively connected with said member, and means movable with

5 said roller for operating said timing means, said element cooperating with said timing means to impart movement to said member in the direction of movement for compressing the filler.

10 13. In a bunching machine, in combination with an apron and a movable roller for rolling the bunch, means for exerting a pull on the apron, means for tensioning the apron-pulling means, and means for timing the ac-

15 tion of said apron-pulling means and also aiding the apron-pulling means in its movement to exert a pull thereon.

14. In a bunching machine, in combination with an apron and a movable roller for

20 rolling the bunch, means for exerting a pull on the apron, means for timing the action of said apron-pulling means relatively to the action of said roller, said timing mechanism including means cooperating with an

25 element movable with said roller for retarding the movement of said roller as said apron pulling means tightens the apron on the filler.

15. In a bunching machine, in combination with an apron and a movable roller for

30 rolling the bunch, means for exerting a pull on the apron, means for timing the release of said apron-pulling means, said timing mechanism including a latch movable with

35 said roller, a member connected to said apron-pulling means and engaged and moved by said latch to place said apron-pulling means under tension, and means whereby said latch is released to permit

40 said apron-pulling means to tighten the apron on the filler.

16. In a bunching machine, in combination with an apron and a movable roller for

45 rolling the bunch, a movable member connected to the apron, means tensioned by the movement of said member in one direction for exerting a pull on said apron, and means for timing the action of said last-named means relatively to the action of said roller,

50 said timing mechanism including means whereby said member moves with said roller for a portion of its stroke and is then released, and means for retarding the movement of said roller while said first-named

55 means is imparting a pull on said apron and then releasing the same.

17. In a bunching machine, in combination with an apron and a movable roller for

60 rolling the bunch, a movable member connected to the apron for tightening the same to contract the filler loop therein, and timing mechanism including means operated by the forward movement of said roller, and means movable with said roller and cooper-

65 ating with said last-named means whereby

said roller is retarded and said first-named member given an initial impulse in its direction of movement for tightening the apron.

18. In a bunching machine, in combination with an apron and a movable roller for

70 rolling the bunch, a movable member connected to the apron, means tensioned by the movement of said member in one direction for exerting a pull on said apron, and means for timing the action of said last-named

75 means relatively to the action of said roller, said timing mechanism including a member connected to said roller, means cooperating with said last-named member for retarding

80 movement of said roller, and means whereby said retarding means are opened to permit free forward movement of said roller as said

means for pulling the apron completes its apron-pulling stroke.

19. In a bunching machine, in combination with relatively movable members for

85 rolling the bunch, a latch movable with the movable member, levers and a toggle actuated by said latch, means holding said latch in position to actuate said toggle and levers

90 and also operating to release the same, and means movable with said movable member and cooperating with said levers to retard said movable member.

20. In a bunching machine, in combination with an apron and a movable connect-

95 ing member for transmitting a pull to said apron, a spring tensioned with the movement of said member in one direction for actuating said member in the opposite direc-

100 tion, and means given momentum by the action of the spring for aiding said spring in its pull on the apron as its tension decreases.

21. In a bunching machine, in combination with an apron and a movable connecting

105 member for transmitting a pull to said apron, a spring tensioned with the movement of said member in one direction for moving said member in its pull-transmitting direc-

110 tion, and a rotatable inertia member rotated by said spring while transmitting a pull to said apron for aiding said spring in overcoming the greatest resistance of the bunch as said first-named member approaches the

115 end of its stroke.

22. In a bunching machine, in combination with an apron and means for transmit-

120 ting a pull to said apron, a spring tensioned by the movement of said means in one direction for actuating said means in its pull-transmitting direction, and an inertia member moved by said spring for aiding the ac-

tion of said spring as its tension decreases.

23. In a bunching machine, in combination with an apron and means for transmit-

125 ting a pull to said apron, a spring tensioned by the movement of said means in one direction for actuating said means in its pull-transmitting direction, and means for aiding

130 said spring and increasing the pull on the

apron as said first-named means moves in its pull-transmitting direction under the action of said spring.

24. In a bunching machine, in combination with an apron and means for transmitting a pull to said apron, a spring tensioned by the movement of said means in one direction for actuating said member in its pull-transmitting direction, and means for adjusting the tension of said spring.

25. In a bunching machine, in combination with an apron and means for transmitting a pull to said apron, a spring tensioned by the movement of said member in one direction for actuating said member in its pull-transmitting direction, an inertia member for aiding said spring in its movement of said member in its pull-transmitting direction, and means for adjusting the tension of said spring.

26. In a bunching machine, in combination with an apron and means for transmitting a pull to said apron, an inertia member movable in opposite directions with said first-named means, and a spring tensioned by the movement of said means in one direction and operated to actuate said means in its pull-transmitting direction and simultaneously impart momentum to said inertia member to supplement the action of said spring.

27. In a bunching machine, in combination with an apron and a movable member for transmitting a pull to said apron, an inertia member movable in opposite directions with said first-named member, a spiral spring wound by the movement of said first-named member in one direction and operated to actuate said member in its pull-transmitting direction and simultaneously impart momentum to said inertia member to supplement the action of said spring.

28. In a bunching machine, in combination with an apron, a movable member for transmitting a pull to said apron, a spring tensioned by the movement of said member in one direction for actuating said member during its pull-transmitting movement, an inertia member actuated by said spring for aiding said spring as its tension decreases, and means cooperating with said movable member after it has been actuated by said spring to lock the same against forward movement.

29. In a bunching machine, in combination with an apron, a movable member for transmitting a pull to said apron, a spring tensioned by the movement of said member in one direction for actuating said member during its pull-transmitting movement, an inertia member actuated by said spring for aiding said spring as its tension decreases, means cooperating with said movable member after it has been actuated by said spring to lock the same against forward movement,

and means to disengage said movable member automatically from its lock when the parts are returned to initial position.

30. In a bunching machine, in combination with an apron, a movable member for transmitting a pull to said apron, a spring tensioned by the movement of said member in one direction for actuating said member in its pull-transmitting direction, and means cooperating with said member after it has been actuated by said spring to lock said member against forward movement.

31. In a bunching machine, in combination with an apron, a movable member for transmitting a pull to said apron, a spring tensioned by the movement of said member in one direction for actuating said member in its pull-transmitting direction, means cooperating with said member after it has been actuated by said member to lock said member against forward movement, and means to disengage said member automatically from its lock when the parts are returned to initial position.

32. In a bunching machine, in combination with an apron and a movable roller to roll the bunch, means operating frictionally on said apron during the return movement of said roller for replacing the apron smoothly and forming a filler-receiving pocket.

33. In a bunching machine, in combination with an apron and a movable roller for rolling the bunch, one or more bands moved with said roller during the bunch-rolling operation and operating frictionally on said apron during the return movement of said roller for replacing the apron smoothly and forming a filler-receiving pocket.

34. In a bunching machine, in combination with an apron, a movable roller for rolling the bunch, and means for returning said roller, means moved with said roller and acting on the apron frictionally during the return movement of said roller for forming a filler-receiving pocket.

35. In a bunching machine, in combination with an apron, a movable roller for rolling the bunch, and means for returning the roller, one or more bands moved with said roller and acting frictionally on the apron during the return movement of said roller for forming a filler-receiving pocket.

36. In a bunching machine, in combination with an apron, a movable roller for rolling the bunch, and means for returning said roller, one or more elongated elements moved with said roller to guide the apron during the return movement of the roller for preventing said apron from falling into the path of the movable parts of the machine.

37. In a bunching machine, in combination with an apron, a movable roller for rolling a bunch, and means for returning

the roller, one or more elongated elements movable with the roller and operating during the return movement of the roller to replace said apron smoothly and form a pocket therein to receive the filler.

38. In a bunching machine, in combination with an apron and a movable roller for rolling the bunch, means for returning the roller including resilient means and means adapted to act by frictionally contacting the apron to form a filler-receiving pocket in said apron.

39. In a bunching machine, in combination with an apron and a movable roller for rolling the bunch, means for returning said roller including one or more elongated elements adapted to act by frictionally contacting the apron to replace the apron smoothly and form a pocket therein for receiving the filler.

40. In a bunching machine, in combination with an apron and a movable roller for rolling the bunch, means for returning the roller including resilient means and one or more bands cooperating with said apron to protect the same and also simultaneously replace the apron smoothly and form a filler-receiving pocket therein.

41. In a bunching machine, in combination with an apron and a movable roller for rolling the bunch, one or more bands moved with said roller and cooperating therewith during the return movement of said roller for forming a filler receiving pocket in the apron, means upon which said band or bands are wound, and resilient means tensioned by the movement of said bands in one direction for returning said bands to initial position as said roller is returned.

42. In a bunching machine, in combination with an apron and a movable roller for rolling the bunch, resilient means for returning said roller tensioned by the forward movement of said roller, and means acting frictionally on said apron during its return for replacing the apron smoothly and forming a filler-receiving pocket.

43. In a bunching machine, in combination with an apron and a movable roller for rolling the bunch, resilient means for returning the roller tensioned by the forward movement of said roller, and one or more elongated elements movable with the roller and acting frictionally on said apron for replacing the apron smoothly and forming the same into a filler-receiving pocket.

44. In a bunching machine, in combination with an apron and a movable roller for rolling the bunch, elongated frictional elements moved with the roller during its rolling operation and acting on the apron during the return of said roller to form a pocket in the apron, and resilient means tensioned by the movement of said elements in

the first-named direction for returning said frictional elements to initial position.

45. In a bunching machine, in combination with an apron and a movable roller for rolling the bunch, one or more bands moved with said roller during its bunch-rolling operation and acting on the apron during the return of said roller for replacing the apron smoothly and forming a pocket in said apron, one or more elements on which said bands are wound, and resilient means tensioned by the first-named movement of said bands for winding said bands on said elements during the return of said roller.

46. In a bunching machine, in combination with an apron and means for transmitting a pull to said apron, and a pivotal connecting element for connecting the end of the apron thereto and providing a free pivotal movement thereof to aid in forming a filler receiving pocket.

47. In a bunching machine, in combination with an apron and a movable member for imparting a pull to said apron, a sleeve secured to the end of the apron, and means on said member for pivotally mounting said sleeve.

48. In a bunching machine, in combination with an apron and a movable roller for rolling the bunch, a carriage movable with the roller, a frame with guide rails on which the carriage reciprocates, anti-friction rollers on the carriage for guiding the carriage in its longitudinal movements, and anti-friction rollers disposed angularly to the first-named anti-friction rollers, for resisting the lateral thrust of said carriage during its longitudinal movements.

49. In a bunching machine, in combination with an apron, roller carrying mechanism, means for returning said roller carrying mechanism, and a resilient buffer for cushioning said roller carrying mechanism when it is returned to normal position.

50. In a bunching machine, in combination with an apron, means for transmitting a pull to said apron, a spring tensioned by the movement of said means in one direction for actuating said means in the opposite direction, and a resilient buffer for cushioning said means when it is returned by the action of said spring.

51. In a bunching machine, in combination with an apron, a member disposed crosswise underneath the apron and adapted to be positioned to shape the pocket formed in said apron to conform to the size and shape of the bunch to be made.

52. In a bunching machine, in combination with an apron, guard plates to prevent scrap filler from falling out of a pocket formed in the apron, and a member disposed crosswise underneath said apron and adapted to be positioned to shape the pocket

formed in said apron to conform to the size and shape of the bunch to be made.

53. In a bunching machine, a bunch gripper including a plurality of resilient arms to form a pocket and a bottom member adjustable to vary the depth of the pocket in said gripper, said member cooperating with said arms to simultaneously adjust the width of said pocket.

54. In a bunching machine, a bunch gripper including a plurality of members forming the side of said gripper, and means cooperating with said sides for simultaneously adjusting the depth and the width of the pocket formed in said gripper.

55. In a bunching machine, a bunch gripper including an adjustable bottom member angularly adjustable to receive bunches of different size and shape.

56. In a bunching machine, a bunch gripper including side members, and means cooperating with said side members for adjusting the depth, the width and the taper of the pocket of said gripper.

57. In a bunching machine, a bunch gripper including side members and means cooperating with said side members for adjusting the depth and the width of the pocket of said gripper, said last-named means being also angularly adjustable to conform with different degrees of taper in the bunch.

58. In a bunching machine, in combination with an apron and a roller, adjustable means for mounting said roller whereby the angularity of said roller may be varied in all directions.

59. In a bunching machine, in combination with an apron and a roller, adjustable means for mounting said roller at one or both ends whereby either or both ends of the roller may be adjusted in any direction.

60. In a bunching machine, in combination with an apron and a roller, adjustable means for mounting said roller whereby said roller may be adjusted in any direction and including means for positively retaining said roller in its positions of adjustment.

61. In a bunching machine, in combination with an apron, a plurality of rollers cooperating with said apron, and means for adjusting the relative angularity of said rollers to form a conical-shaped filler loop.

62. In a bunching machine, in combination with an apron, a plurality of rollers cooperating with said apron, and means whereby one of said rollers may be adjusted in any direction with respect to another roller into parallel relation therewith or angular relation therewith to form a conical-shaped filler loop.

63. In a bunching machine, in combination with an apron, a plurality of rollers cooperating with said apron, and means at one

or both ends of at least one of said rollers whereby said roller may be adjusted in any direction with respect to another roller.

64. In a bunching machine, in combination with an apron, rollers cooperating with said apron, and means for adjusting the relative angularity of said rollers including means for positively retaining said rollers in their positions of relative adjustment.

65. In a bunching machine, in combination with an apron and a roller for rolling a bunch, means for adjustably mounting said roller whereby the angularity of said roller may be varied, and means for adjusting said apron to take up slack therein.

66. In a bunching machine, in combination with an apron and a plurality of rollers for rolling a bunch, means mounting said rollers whereby one or both of said rollers may be adjusted angularly, and means for adjusting said apron to take up slack therein.

67. In a bunching machine, in combination with an apron and a roller for rolling a bunch, an adjusting plate provided with a plurality of apertures variously located for adjustably carrying said roller in an angular position.

68. In a bunching machine, in combination with an apron and one or more rollers for rolling a bunch, a plurality of adjusting plates provided with a plurality of apertures variously located for adjusting the angular position of said roller or rollers.

69. In a cigar bunching machine separate members comprising, respectively, an apron having a filler receiving pocket and a roller, one of said members being movable relative to the other member, a pin movable with the movable member, a toggle device having a normally open end, means operated by the movable member for closing the open end of the toggle device across the path of the pin to stop the movable member, and means operating independently of the movable member for successively contracting the pocket about the filler therein and opening the toggle device to release the pin and movable member.

70. In a cigar bunching machine an apron having a filler receiving pocket, a roller movable relative to the apron for closing the pocket and rolling the filler within the apron, a spring restrained wheel, a connection between said wheel and the apron, means for coupling the connection to the roller during the initial movement of said roller relative to the apron to close the pocket and means for automatically releasing said connection from the roller to contract the closed pocket about the filler therein during the continued movement of the roller.

71. In a cigar bunching machine, an apron having a filler receiving pocket, a roller mov-

able relative to the apron, a spring restrained wheel, a connection between said wheel and the apron, means for automatically coupling said connection with the roller during the initial movement of the roller during the closing of the pocket about a filler, means for automatically disconnecting the roller from said connection thereby to tighten the pocket about the filler therein, and means released by the return of said connection to normal position for holding the roller momentarily against movement.

72. A cigar bunching machine including an apron having a pocket for receiving a filler, a roller movable relative to the apron, yielding means for holding the roller normally in one position, a spring, a connection between said spring and one end of the apron, means for automatically coupling the connection to the roller during the first portion of the forward movement of the roller, thereby to place the spring under increased tension, said roller constituting means for closing the pocket about the filler therein, adjustable means controlled by the movement of the roller for automatically releasing said connection from the roller for actuation by the spring to contract the pocket about the filler therein, and means for holding the roller momentarily against forward movement during the return movement of the connection.

73. A cigar bunching machine including an apron having a filler receiving pocket, a roller, said apron and roller being mounted for relative movement, a wheel, a spring for actuating the wheel in one direction, a connection between said wheel and one end of the apron, means for coupling the roller to said connection during the relative movement of the roller and apron for simultaneously closing the pocket about the filler therein and rotating the wheel to place the spring under increased tension, means for releasing said connection from the roller to allow actuation of the wheel by the spring and effect contraction of the pocket about the filler therein.

74. A cigar bunching machine including an apron having a filler receiving pocket, a roller movable relative to the apron, a wheel, a spring for actuating the wheel in one direction, a connection between said wheel and one end of the apron, means for coupling the roller to said connection for simultaneously closing the pocket about the filler therein and rotating the wheel to place the spring under increased tension, means for releasing said connection from the roller to allow actuation of the wheel by the spring and effect contraction of the pocket about the filler therein, and means for holding the roller against forward movement until the connection has returned to normal position following the contraction of the pocket.

75. In a cigar bunching machine an apron having a filler receiving pocket, a roller movable relative to the apron for successively closing the pocket and thereafter rolling said pocket with the filler therein, a wheel, a spring for actuating the same, a connection between the wheel and one end of the apron, means for automatically coupling said connection to the roller during the closing of the pocket about the filler, means adjustable to release said connection from the roller after the closing of the socket, thereby to release the spring actuated wheel to return the connection to normal position and draw the pocket taut about the filler therein, means for holding the roller against forward movement during the return movement of the connection, said means including a toggle device normally open at one end, means operated by the connection during its movement with the roller for closing the open end of the toggle device, and means movable with the roller against the closed end of the toggle device for stopping the movement of the roller, said connection, when released from the roller, constituting means for opening the toggle device.

In testimony that I claim the foregoing as my own, I have hereto affixed my signature.

CHARLES A. NEUBAUER.