

(19)



(11)

EP 4 265 829 B1

(12)

EUROPEAN PATENT SPECIFICATION

(45) Date of publication and mention of the grant of the patent:
05.03.2025 Bulletin 2025/10

(21) Application number: **23162283.8**

(22) Date of filing: **16.03.2023**

(51) International Patent Classification (IPC):
D02G 1/02^(2006.01) D02J 13/00^(2006.01)

(52) Cooperative Patent Classification (CPC):
D02J 13/003; D02G 1/0266

(54) **HEATER**

HEIZKÖRPER

DISPOSITIF DE CHAUFFAGE

(84) Designated Contracting States:
AL AT BE BG CH CY CZ DE DK EE ES FI FR GB GR HR HU IE IS IT LI LT LU LV MC ME MK MT NL NO PL PT RO RS SE SI SK SM TR

(30) Priority: **15.04.2022 JP 2022067809**

(43) Date of publication of application:
25.10.2023 Bulletin 2023/43

(73) Proprietor: **TMT Machinery, Inc. Osaka-shi, Osaka 541-0041 (JP)**

(72) Inventors:
• **HORIMOTO, Takayuki**
Kyoto-shi, Kyoto, 612-8686 (JP)
• **KITAGAWA, Shigeki**
Kyoto-shi, Kyoto, 612-8686 (JP)

(74) Representative: **Hoffmann Eitle Patent- und Rechtsanwälte PartmbB**
Arabellastraße 30
81925 München (DE)

(56) References cited:
WO-A1-2006/129558 JP-A- 2006 022 411

EP 4 265 829 B1

Note: Within nine months of the publication of the mention of the grant of the European patent in the European Patent Bulletin, any person may give notice to the European Patent Office of opposition to that patent, in accordance with the Implementing Regulations. Notice of opposition shall not be deemed to have been filed until the opposition fee has been paid. (Art. 99(1) European Patent Convention).

Description

BACKGROUND OF THE INVENTION

[0001] The present invention relates to a heater configured to heat a yarn.

[0002] Patent Literature 1 (Japanese Laid-Open Patent Publication No. 2002-194631) discloses a heater provided in a false-twist texturing machine (textile machine) configured to perform false twisting of a running yarn. To be more specific, the heater includes a sheathed heater (heat source), a heating body (heating unit) extending in a predetermined extending direction, and a contact plate (yarn contacted member) which is attached to the heating unit and which is heated by the heat source. The yarn contacted member is provided with a yarn contacted surface curved to be reliably made contact with the yarn. With this arrangement, the yarn running while being in contact with the yarn contacted surface is heated by means of heat conduction.

[0003] Further relevant information can also be found in documents JP 2006-022411 and EP 3 210 919.

SUMMARY OF THE INVENTION

[0004] The specifications (to be more specific, a suitable curvature of a yarn path formed by the yarn contacted surface) of the above-described heater may vary mainly because of the layout of the textile machine forming the yarn path. Traditionally, a yarn contacted member is processed in advance based on the specifications of a heater so that a yarn path has a suitable curvature. Therefore, production cost is high.

[0005] An object of the present invention is to achieve the reduction in production cost of a yarn contacted member applied to a heater.

[0006] A heater according to a first aspect of the invention is configured to heat a running yarn, and includes: a heat source; a heating unit which extends in a predetermined extending direction and which is heated by the heat source; a yarn contacted member which has a yarn contacted surface, which extends at least in the extending direction, and which is heated by the heating unit, the yarn making contact with the yarn contacted surface; and an attaching portion which includes the heating unit and to which the yarn contacted member is attached. In this regard, the yarn contacted surface extends at least in the extending direction and is oriented at least to one side in a predetermined height direction orthogonal to the extending direction. This heater further includes an elastic deformation holding unit configured to hold the yarn contacted member attached to the attaching portion while elastically deforming the yarn contacted member viewed in a width direction orthogonal to the extending direction and the height direction. When the yarn contacted member is elastically deformed and held by the elastic deformation holding unit, a cross sectional curve in a cross section orthogonal to the width direction of the yarn

contacted member has a predetermined curvature.

[0007] According to this aspect, the cross sectional curve of the yarn contacted surface has a predetermined curvature in such a way that the elastic deformation holding unit holds the yarn contacted member which is attached to the attaching portion while being elastically deformed. In other words, even when the yarn contacted member is produced to linearly extend and is attached to the heater, the yarn contacted surface has a desired shape only in such a way that the yarn contacted member is elastically deformed. With this arrangement, the production cost of the yarn contacted member is reduced as compared to a case where the yarn contacted member is processed based on the specifications of the heater. It is therefore possible to achieve the reduction in production cost of the yarn contacted member applied to the heater.

[0008] According to a second aspect of the invention, the heater of the first aspect is arranged such that the elastic deformation holding unit is configured to hold the yarn contacted member so that the yarn contacted member is attachable to and detachable from the attaching portion.

[0009] Typically, a member with which the running yarn makes contact is cleaned according to need. In this regard, the heater may be provided at a position higher than the stature of an operator who cleans the member. Therefore, when the yarn contacted member cannot be detached from the attaching portion, the cleaning of the member may be difficult depending on the position of the heater. The present invention makes it possible to detach the yarn contacted member from the attaching portion at the time of cleaning. It is therefore possible to improve the work efficiency in cleaning of the yarn contacted member, irrespective of the position of the heater.

[0010] According to a third aspect of the invention, the heater of the second aspect is arranged such that an attachment-detachment path through which the yarn contacted member is able to pass in the height direction at the time of attachment and detachment of the yarn contacted member is formed in the attaching portion.

[0011] For example, the yarn contacted member may be attached to and detached from the attaching portion by being inserted in and pulled out from the attaching portion in the extending direction. In this case, however, a long space provided for the attachment and detachment of the yarn contacted member is required at a position adjacent to the heater in the extending direction. This puts a large limit on the layout of the heater and its surroundings. According to this aspect, the yarn contacted member is attachable to and detachable from the attaching portion by moving the yarn contacted member in the height direction. In this case, the above-described long space at the position adjacent to the heater in the extending direction is not required. It is therefore possible to suppress the occurrence of disadvantages such as the limit on the layout of the heater and its surroundings.

[0012] According to a fourth aspect of the invention, the heater of any one of the first to third aspects is arranged

such that the elastic deformation holding unit includes: a first force portion configured to apply the force toward one side in the height direction to a first part of the yarn contacted member attached to the attaching portion, the first part being at a predetermined position in the extending direction; a second force portion configured to apply the force toward the other side in the height direction to a second part of the yarn contacted member attached to the attaching portion, the second part being provided on one side in the extending direction as compared to the first part; and a third force portion configured to apply the force toward the other side in the height direction to a third part of the yarn contacted member attached to the attaching portion, the third part being provided on the other side in the extending direction as compared to the first part.

[0013] According to this aspect, the force toward one side in the height direction is applied to a part of the yarn contacted member in the extending direction. Relative to this part, one part of the yarn contacted member is provided on one side in the extending direction and another part of the yarn contacted member is provided on the other side in the extending direction. The force toward the other side in the height direction is applied to these two parts. With this arrangement, the yarn contacted member is warped. It is therefore possible to elastically deform the yarn contacted member with a simple structure.

[0014] According to a fifth aspect of the invention, the heater of the fourth aspect is arranged such that the first force portion includes a first regulatory portion which is provided on the other side in the height direction as compared to the first part and which is configured to regulate the movement of the first part toward the other side in the height direction, the second force portion includes a second regulatory portion which is provided on one side in the height direction as compared to the second part and which is configured to regulate the movement of the second part toward one side in the height direction, and the third force portion includes a third regulatory portion which is provided on one side in the height direction as compared to the third part and which is configured to regulate the movement of the third part toward one side in the height direction.

[0015] According to this aspect, the force toward one side in the height direction is applied to the first part on account of the law of action and reaction in such a way that the first regulatory portion regulates the movement of the first part toward the other side in the height direction. The force toward the other side in the height direction is applied to the second part and the third part on account of the law of action and reaction in such a way that the second regulatory portion and the third regulatory portion regulate the movement of the second part and third part toward one side in the height direction. It is therefore possible to elastically deform the yarn contacted member with a simple structure.

[0016] According to a sixth aspect of the invention, the

heater of the fifth aspect is arranged such that, when each of the second regulatory portion and the third regulatory portion is viewed in the height direction, the each of the second regulatory portion and the third regulatory portion is movable between a retracted position which does not overlap the yarn contacted member and an overlapping position which overlaps the yarn contacted member.

[0017] According to this aspect, when the yarn contacted member is to be attached to the attaching portion, the yarn contacted member is attached to the attaching portion in such a simple way that (i) the each of the second regulatory portion and the third regulatory portion is temporarily moved to the retracted position and then (ii) the each of the second regulatory portion and the third regulatory portion is moved back to the overlapping position while the yarn contacted member is warped. When the yarn contacted member is attachable to and detachable from the attaching portion, the yarn contacted member is detached from the attaching portion in such a simple way that the each of the second regulatory portion and the third regulatory portion is temporarily moved to the retracted position.

[0018] According to a seventh aspect of the invention, the heater of the sixth aspect further includes a biasing portion configured to bias the each of the second regulatory portion and the third regulatory portion from the retracted position to the overlapping position.

[0019] This suppresses the each of the second regulatory portion and the third regulatory portion from being unintentionally moved from the overlapping position to the retracted position.

[0020] According to an eighth aspect of the invention, the heater of the sixth or seventh aspect further includes a swing axis configured to swingably support the each of the second regulatory portion and the third regulatory portion.

[0021] The second regulatory portion and the third regulatory portion may be movable in a parallel manner. In this case, however, a large space is required for the movement of the second regulatory portion and the third regulatory portion. According to this aspect, for example, when the yarn contacted member is to be attached to the attaching portion in the production of the heater (or when the yarn contacted member which is attachable to and detachable from the attaching portion is to be detached from the attaching portion), a space required for the movement of the second regulatory portion and the third regulatory portion is downsized.

[0022] According to a ninth aspect of the invention, the heater of any one of the fifth to eighth aspects is arranged such that the position of at least one of the first regulatory portion, the second regulatory portion, and the third regulatory portion is changeable with respect to the attaching portion in at least one of the extending direction and the height direction.

[0023] According to this aspect, the curvature of the cross sectional curve of the yarn contacted surface is adjustable according to need even after the heater is set.

BRIEF DESCRIPTION OF THE DRAWINGS

[0024]

FIG. 1 is a profile of a false-twist texturing machine including a first heater of an embodiment.

FIG. 2 is a schematic diagram of the false-twist texturing machine, expanded along paths of yarns. Each of FIGs. 3(a) to 3(e) shows the structure of the first heater.

Each of FIGs. 4(a) and 4(b) shows the structure of the first heater.

FIG. 5 shows a warping unit.

Each of FIGs. 6(a) to 6(d) shows a hook unit viewed in an extending direction.

Each of FIGs. 7(a) and 7(b) shows the hook unit viewed in a width direction.

DESCRIPTION OF THE PREFERRED EMBODIMENTS

[0025] The following will describe an embodiment of the present invention. Hereinafter, the direction perpendicular to the sheet of FIG. 1 will be referred to as a base longitudinal direction. Hereinafter, the left-right direction of the sheet of FIG. 1 will be referred to as a base width direction. Hereinafter, the direction orthogonal to the base longitudinal direction and the base width direction will be referred to as an up-down direction (vertical direction) in which the gravity acts.

(Overall Structure of False-Twist Texturing Machine)

[0026] The following will describe the overall structure of a false-twist texturing machine 1 including a first heater 13 (heater of the present invention: details thereof will be described later) of the present embodiment, with reference to FIG. 1 and FIG. 2. FIG. 1 is a profile of the false-twist texturing machine 1. FIG. 2 is a schematic diagram of the false-twist texturing machine 1, expanded along paths of yarns Y (yarn paths).

[0027] The false-twist texturing machine 1 is able to perform false twisting of yarns Y (to false-twist yarns Y) made of synthetic fibers (e.g., polyester). Each yarn Y is, e.g., a multi-filament yarn formed of filaments. Alternatively, each yarn Y may be formed of a single filament. The false-twist texturing machine 1 includes a yarn supplying unit 2, a processing unit 3, and a winding unit 4. The yarn supplying unit 2 is able to supply yarns Y. The processing unit 3 is configured to pull out the yarns Y from the yarn supplying unit 2, and to false-twist the yarns Y. The winding unit 4 is configured to wind the yarns Y processed by the processing unit 3 onto winding bobbins Bw. Components of the yarn supplying unit 2, the processing unit 3, and the winding unit 4 are aligned to form plural lines (see FIG. 2) in the base longitudinal direction. The base longitudinal direction is a direction orthogonal to a running plane (plane of FIG. 1) of the yarns Y. The

running plane of the yarns Y is formed of the yarn paths extending from the yarn supplying unit 2 to the winding unit 4 through the processing unit 3.

[0028] The yarn supplying unit 2 includes a creel stand 7 retaining yarn supply packages Ps, and is configured to supply the yarns Y to the processing unit 3. The processing unit 3 is configured to pull out the yarns Y from the yarn supplying unit 2, and to process the yarns Y. In the processing unit 3, the following members are provided in this order from the upstream side in a yarn running direction: each first feed roller 11; each twist-stopping guide 12; each first heater 13; each cooler 14; each false-twisting device 15; each second feed roller 16; each interlacing device 17; each third feed roller 18; a second heater 19; and each fourth feed roller 20. The winding unit 4 includes winding devices 21. Each winding device 21 is configured to wind a yarn Y for which the false twisting has been performed by the processing unit 3 onto a winding bobbin Bw, and to form a wound package Pw.

[0029] The false-twist texturing machine 1 includes a main frame 8 and a winding base 9 which are spaced apart from each other in the base width direction. The main frame 8 and the winding base 9 are substantially identical in length in the base longitudinal direction. The main frame 8 and the winding base 9 oppose each other in the base width direction. The false-twist texturing machine 1 includes units termed spans each of which includes a pair of the main frame 8 and the winding base 9. In one span, each device is placed so that the false twisting is simultaneously performable for the yarns Y running while being aligned in the base longitudinal direction. In the false-twist texturing machine 1, the spans are placed in a left-right symmetrical manner to the sheet, with a center line C of the base width direction of the main frame 8 as a symmetry axis. (That is, the main frame 8 is shared between the left span and the right span.) The spans are aligned in the base longitudinal direction.

(Processing Unit)

[0030] The following will describe the structure of the processing unit 3 with reference to FIG. 1 and FIG. 2. Each first feed roller 11 is configured to unwind a yarn Y from one yarn supply package Ps attached to the yarn supplying unit 2, and to send the yarn Y to one first heater 13. As shown in FIG. 2, each first feed roller 11 is configured to send, e.g., a single yarn Y to the first heater 13. Alternatively, each first feed roller 11 may be able to send plural adjacent yarns Y to the downstream side in the yarn running direction. Each twist-stopping guide 12 prevents twisting, which is applied to a yarn Y by one later-described false-twisting device 15, from being propagated to the upstream of each twist-stopping guide 12 in the yarn running direction.

[0031] Each first heater 13 is configured to increase the temperature of yarns Y sent from some first feed rollers 11 to a predetermined processing temperature. As shown in FIG. 2, each first heater 13 is able to heat, e.g., two yarns

Y. Below the first heater 13, there is a working space S (see FIG. 1) provided for an operator to perform yarn threading, etc. Each first heater 13 will be detailed later.

[0032] Each cooler 14 is configured to cool a yarn Y heated by one first heater 13. As shown in FIG. 2, each cooler 14 is configured to cool, e.g., a single yarn Y. Alternatively, the cooler 14 may be able to simultaneously cool plural yarns Y. Each false-twisting device 15 is provided downstream of one cooler 14 in the yarn running direction, and configured to twist a yarn Y. Each false-twisting device 15 is, e.g., a so-called disc-friction false-twisting device. However, the disclosure is not limited to this. Each second feed roller 16 is configured to send a yarn Y processed by one false-twisting device 15 to one interlacing device 17. The conveyance speed of conveying the yarn Y by each second feed roller 16 is higher than the conveyance speed of conveying the yarn Y by each first feed roller 11. Because of this, the yarn Y is therefore drawn and false-twisted between each first feed roller 11 and each second feed roller 16.

[0033] Each interlacing device 17 is configured to interlace a yarn Y. Each interlacing device 17 has, e.g., a known interlace nozzle configured to interlace the yarn Y by means of an airflow.

[0034] Each third feed roller 18 is configured to send, to the second heater 19, a yarn Y running on the downstream side of one interlacing device 17 in the yarn running direction. As shown in FIG. 2, each third feed roller 18 is configured to send, e.g., a single yarn Y to the second heater 19. Alternatively, each third feed roller 18 may be able to send plural adjacent yarns Y to the downstream side in the yarn running direction. The conveyance speed of conveying the yarn Y by each third feed roller 18 is lower than the conveyance speed of conveying the yarn Y by each second feed roller 16. The yarn Y is therefore relaxed between each second feed roller 16 and each third feed roller 18. The second heater 19 is configured to heat yarns Y sent from some third feed rollers 18. The second heater 19 extends along the vertical direction, and is provided for each of the spans. Each fourth feed roller 20 is configured to send a yarn Y heated by the second heater 19 to one winding device 21. As shown in FIG. 2, each fourth feed roller 20 is able to send, e.g., a single yarn Y to the winding device 21. Alternatively, each fourth feed roller 20 may be able to send plural adjacent yarns Y to the downstream side in the yarn running direction. The conveyance speed of conveying the yarn Y by each fourth feed roller 20 is lower than the conveyance speed of conveying the yarn Y by each third feed roller 18. The yarn Y is therefore relaxed between each third feed roller 18 and each fourth feed roller 20.

[0035] In the processing unit 3 arranged as described above, each yarn Y drawn between the first feed roller 11 and the second feed roller 16 is twisted by the false-twisting device 15. The twist formed by the false-twisting device 15 propagates to the twist-stopping guide 12, but does not propagate to the upstream side of the twist-

stopping guide 12 in the yarn running direction. The yarn Y which is twisted and drawn is heated by the first heater 13 and thermally set. After that, the yarn Y is cooled by the cooler 14. The yarn Y is untwisted on the downstream side of the false-twisting device 15 in the yarn running direction. However, the yarn Y is maintained to be wavy in shape on account of the thermal setting described above (i.e., crimp contraction of the yarn Y is maintained).

[0036] After being false-twisted, the yarn Y is interlaced by the interlacing device 17 while being relaxed between the second feed roller 16 and the third feed roller 18. The yarn Y is then guided to the downstream side in the yarn running direction. Furthermore, the yarn Y is thermally set by the second heater 19 while being relaxed between the third feed roller 18 and the fourth feed roller 20. Finally, the yarn Y which is sent from the fourth feed roller 20 is wound by the winding device 21.

(Winding Unit)

[0037] The following will describe the structure of the winding unit 4 with reference to FIG. 2. The winding unit 4 includes plural winding devices 21. Each winding device 21 is able to wind one yarn Y onto one winding bobbin Bw. The winding device 21 includes a fulcrum guide 31, a traverse unit 32, and a cradle 33. The fulcrum guide 31 is a guide functioning as a fulcrum when the yarn Y is traversed. The traverse unit 32 is able to traverse the yarn Y by means of a traverse guide 34. The cradle 33 is configured to rotatably support the winding bobbin Bw. A contact roller 35 is provided in the vicinity of the cradle 33. The contact roller 35 is configured to make contact with a surface of one wound package Pw so as to apply a contact pressure to the surface of the wound package Pw. In the winding unit 4 arranged as above, the yarn Y sent from the above-described fourth feed roller 20 is wound onto the winding bobbin Bw by the winding device 21 so that the wound package Pw is formed.

(First Heater)

[0038] The following will detail each first heater 13 with reference to FIGs. 3(a) to 3(e) and FIGs. 4(a) and 4(b). FIG. 3(a) shows one first heater 13 viewed in the base longitudinal direction. FIG. 3(a) illustrates the first heater 13 extending along the left-right direction of the sheet of FIG. 3(a). FIG. 3(b) is a cross section of the first heater 13, which is taken along a direction orthogonal to the base longitudinal direction. FIG. 3(b) illustrates a yarn contacted surface 57 (described later) of a yarn contacted member 43 (described later). FIG. 3(c) is an enlarged view of a left end part of FIG. 3(b). FIG. 3(d) is an enlarged view of one end of the yarn contacted member 43 of the first heater 13 in an extending direction. FIG. 3(e) is a cross section taken along a line III(e)-III(e) in FIG. 3(d). FIG. 4(a) is a view of FIG. 3(a) viewed along an arrow IV(a) in FIG. 3(a). FIG. 4(b) is a cross section taken along a line IV(b)-IV(b) in FIG. 3(a).

[0039] For the sake of convenience, hereinafter, the left-right direction of the sheet of each of FIGs. 3(a) and 3(b) will be referred to as the extending direction in which the first heater 13 extends. In this regard, the extending direction is orthogonal to the base longitudinal direction. The left side of the sheet of each of FIGs. 3(a) and 3(b) is defined as one side in the extending direction, and the right side of the sheet of each of FIGs. 3(a) and 3(b) is defined as the other side in the extending direction. Hereinafter, the direction orthogonal to the base longitudinal direction and the extending direction will be referred to as a height direction. The lower side of the sheet of each of FIGs. 3(a) and 3(b) and FIGs. 4(a) and 4(b) is defined as one side in the height direction, and the upper side of the sheet of each of FIGs. 3(a) and 3(b) and FIGs. 4(a) and 4(b) is defined as the other side in the height direction. Although not illustrated, these descriptions and definitions of the directions are also applied to FIGs. 3(c) to 3(e), FIGs. 6(a) to 6(d), and FIGs. 7(a) and 7(b) described later. In the first heater 13, specifically, one side in the height direction is close to the working space S (see FIG. 1) as compared to the other side in the height direction. Hereinafter, one side in the height direction may be referred to as the "working space S side". Furthermore, the other side in the height direction may be referred to as the "opposite side from the working space S". Hereinafter, the base longitudinal direction may be referred to as a width direction (see FIG. 3(e), FIG. 4(a), and FIG. 4(b)). The width direction is orthogonal to the extending direction and the height direction.

[0040] The first heater 13 is configured to heat at least one running yarn Y. In the present embodiment, the first heater 13 is able to heat, e.g., two yarns Y (yarns YA and YB: see FIG. 4(a)). The first heater 13 includes two heating units 41 (heating units 41A and 41B: an attaching portion of the present invention), a heat source 42, and two yarn contacted members 43 (yarn contacted members 43A and 43B). The first heater 13 is structured so that (i) the heat source 42 heats the yarn contacted members 43A and 43B attached to the respective heating units 41A and 41B and (ii) the running yarns YA and YB are allowed to make contact with the respective yarn contacted members 43A and 43B. With this arrangement, the yarns YA and YB are heated.

[0041] Each heating unit 41 (attaching portion of the present invention) is heated by the heat source 42. Each heating unit 41 is configured to transfer heat, which is generated by the heat source 42, to a corresponding yarn contacted member 43 mainly by means of heat conduction. Each heating unit 41 linearly extends along the extending direction. The length of each heating unit 41 in a predetermined direction is, e.g., 1.0 m or more and 1.5 m or less. When viewed in the extending direction as shown in FIGs. 4(a) and 4(b), the heating units 41A and 41B are provided to sandwich the heat source 42 in a symmetrical manner. Although not illustrated, when viewed in the extending direction, a heat insulation member (not illustrated) is provided to surround each heating

unit 41. Each heating unit 41 (heating unit 41A, 41B) includes, e.g., a first heating member 54 (first heating member 54A, 54B) and a second heating member 55 (second heating member 55A, 55B). Each first heating member 54 and each second heating member 55 may be made of the same material (e.g., brass). Alternatively, each first heating member 54 and each second heating member 55 may be made of different materials.

[0042] Each first heating member 54 is, e.g., substantially rectangular in shape (see FIG. 4(b)) in a cross section orthogonal to the extending direction. In this cross section, for example, each first heating member 54 is long in the height direction. Each first heating member 54 is in contact with the heat source 42. A contact surface between each first heating member 54 and the heat source 42 is in accordance with the outer shape of the heat source 42. The first heating members 54A and 54B are provided to be adjacent to each other in the width direction. The first heating members 54A and 54B are provided to surround the heat source 42.

[0043] Each second heating member 55 is, e.g., substantially L-shaped (see FIG. 4(b)) in a cross section orthogonal to the extending direction. In this cross section, for example, each second heating member 55 is relatively long in the height direction. In this cross section, a part of each second heating member 55 on the other side in the height direction protrudes in the width direction toward a corresponding first heating member 54 belonging to the same heating unit 41. Each second heating member 55 is provided to be adjacent to a corresponding first heating member 54 belonging to the same heating unit 41 in the width direction. In each second heating member 55, the above-described part protruding in the width direction is in contact with a corresponding first heating member 54. In the width direction, a housing space 56 (housing space 56A, 56B) is formed between each first heating member 54 and each second heating member 55. Each housing space 56 is open on one side (the working space S side) in the height direction. In a cross section orthogonal to the extending direction, for example, each housing space 56 is long in the height direction and substantially rectangular in shape. Each housing space 56 (attachment-detachment path of the present invention) is provided for housing a corresponding yarn contacted member 43. For example, each housing space 56 may be provided with an unillustrated lid which is openable and closeable and which is provided on the working space S side in the height direction of the heating unit 41.

[0044] Each first heating member 54 and each second heating member 55 may be shaped differently from above. Alternatively, each heating unit 41 may not include a corresponding first heating member 54 and a corresponding second heating member 55 but may include a single heating member (not illustrated). For example, this heating member may be formed in such a way that a solid rod member is cut to be shaped as a combination of the shape of the first heating member 54 and that of the

second heating member 55.

[0045] In the extending direction, cover members 51 are provided at both ends of each heating unit 41 and its surroundings so as to surround a part of each heating unit 41. Each cover member 51 is substantially U-shaped when viewed in the extending direction. Each cover member 51 is open on one side (the working space S side) in the height direction.

[0046] The heat source 42 is configured to heat each yarn contacted member 43 through each heating unit 41. The heat source 42 is, e.g., a known sheathed heater (electric heater). The sheathed heater includes a heating wire (such as a coil) and a pipe surrounding the heating wire. The sheathed heater is configured to generate Joule heat when an electrical current flows in the heating wire. The heat source 42 extends along the extending direction (see FIG. 3(a)). The heat source 42 is provided to be surrounded by the heating units 41.

[0047] Each yarn contacted member 43 (yarn contacted member 43A, 43B) is attached to a corresponding heating unit 41. Each yarn contacted member 43 is heated by a corresponding heating unit 41 (a first heating member 54 and a second heating member 55). Each yarn contacted member 43 is formed in such a way that, e.g., a stainless steel (SUS) member is cut and processed. Each yarn contacted member 43 extends at least in the extending direction. The yarn contacted members 43A and 43B are housed in the respective housing spaces 56A and 56B. Each yarn contacted member 43 is provided to be in contact with a corresponding heating unit 41. An inner part of each yarn contacted member 43 in the width direction is provided with a yarn contacted surface 57 (see FIG. 3(d) and FIG. 3(e)) which is oriented at least to one side (the working space S side) in the height direction and with which a yarn Y makes contact. For example, each yarn contacted surface 57 is curved so that (i) its both end portions in the extending direction are provided on the other side in the height direction as compared to the remaining parts of each yarn contacted surface 57 and (ii) its center portion is provided on one side in the height direction as compared to the remaining parts of each yarn contacted surface 57. With this arrangement, a curve 59 (see FIGs. 3(b) and 3(c)) in a cross section orthogonal to the width direction of each yarn contacted surface 57 (hereinafter, this curve will be referred to as the cross sectional curve 59) has a predetermined curvature. A pair of regulatory walls 58 configured to regulate the movement of a yarn Y in the width direction are provided outside the both end portions of each yarn contacted surface 57 in the width direction. In each yarn contacted member 43, a yarn path for the yarn Y to run is formed by the yarn contacted surface 57 and the regulatory walls 58.

[0048] In the false-twist texturing machine 1, (i) the positional relationship between the first heater 13 and the twist-stopping guide 12 and (ii) the positional relationship between the first heater 13 and the cooler 14 are appropriately arranged so that running yarns Y reliably

make contact with the respective yarn contacted surfaces 57. In this regard, a predetermined tension is applied to each yarn Y. With this arrangement, force is applied to each yarn Y so as to move each yarn Y toward a corresponding yarn contacted surface 57 in the height direction. It is therefore possible to prevent each yarn Y from moving away from a corresponding yarn contacted surface 57.

[0049] In the first heater 13 arranged as described above, the heat generated by the heat source 42 is transferred to each yarn contacted member 43 through each heating unit 41 (a first heating member 54 and a second heating member 55). With this arrangement, each yarn contacted member 43 is heated so that a yarn Y in contact with the yarn contacted surface 57 of each yarn contacted member 43 is heated (in a contact manner).

[0050] The specifications (to be more specific, a suitable curvature of a yarn contacted surface) of the first heater 13 may vary mainly because of the layout of the false-twist texturing machine 1 forming each yarn path. In a traditional heater (not illustrated), a yarn contacted member (not illustrated) is processed in advance based on the specifications of the heater so that each yarn path has a suitable curvature. Therefore, production cost of the yarn contacted member (not illustrated) is high. In order to achieve the reduction in production cost of each yarn contacted member 43, the first heater 13 of the present embodiment is structured as described below.

(Specific Structure of First Heater)

[0051] The following will describe the specific structure of each first heater 13 with reference to FIG. 4(a) to FIG. 7(b). FIG. 5 is a schematic diagram of later-described warping units 61 (a first force portion and a first regulatory portion of the present invention). Each of FIGs. 6(a) and 6(b) shows a later-described hook unit 62 viewed from one side in the extending direction. Each of FIGs. 6(c) and 6(d) shows a later-described hook unit 63 viewed from the other side in the extending direction. The up-down direction of the sheet of each of FIGs. 6(a) to 6(d) is in parallel to the height direction. The left-right direction of the sheet of each of FIGs. 6(a) to 6(d) is in parallel to the width direction. Each of FIGs. 7(a) and 7(b) shows the hook units 62 and 63 viewed in the width direction (base longitudinal direction). In the following explanation, a reference position is set at a position where a later-described warping unit 61C (see FIG. 4(b) and FIG. 5) is provided in the extending direction. In FIG. 5, for example, the left side of the warping unit 61C in the sheet is defined as one side in the extending direction, and the right side of the warping unit 61C in the sheet is defined as the other side in the extending direction.

[0052] The following describes only a structure (to be more specific, a structure shown in a right part of the sheet of FIG. 4(a)) provided for heating one of two yarns Y in the first heater 13. This structure provided for heating

one of two yarns Y is the same as a structure provided for heating the other of two yarns Y. Therefore, the explanation of the structure provided for heating the other of two yarns Y is omitted.

[0053] To begin with, a yarn contacted member 43 of the present embodiment is structured as described below. As a matter of course, before the yarn contacted member 43 is attached to a heating unit 41, no external force is applied to the yarn contacted member 43 from the heating unit 41. At this time, the yarn contacted member 43 extends to be substantially linear (e.g., see two-dot chain lines of FIG. 5). In this regard, a yarn contacted surface 57 also extends to be substantially linear in a direction in which the yarn contacted member 43 extends. The yarn contacted member 43 is attachable to and detachable from the heating unit 41 as described later.

[0054] As shown in FIG. 4(a) to FIG. 7(b), the first heater 13 further includes an elastic deformation holding unit 60 configured to hold the yarn contacted member 43 so that the yarn contacted member 43 is attachable to and detachable from the heating unit 41. The elastic deformation holding unit 60 is configured to hold the yarn contacted member 43, which is attached to the heating unit 41, while elastically deforming the yarn contacted member 43 (as described later). The elastic deformation holding unit 60 includes, e.g., the warping units 61 (see FIG. 4(b) and FIG. 5), the hook unit 62 (see FIG. 4(a), FIG. 6(a), FIG. 6(b), and FIG. 7(a)), and the hook unit 63 (see FIG. 6(c), FIG. 6(d), and FIG. 7(b)). The warping units 61, the hook unit 62, and the hook unit 63 are attached to the heating unit 41. The warping units 61, the hook unit 62, and the hook unit 63 are configured to elastically deform the yarn contacted member 43 and to keep the yarn contacted member 43 elastically deformed.

[0055] The warping units 61 are in contact with some parts of the yarn contacted member 43 in the extending direction, and configured to regulate the movement of the yarn contacted member 43 toward the other side (opposite side from the working space S) in the height direction. The warping units 61 are provided on the other side (opposite side from the working space S) in the height direction as compared to the yarn contacted member 43. Each warping unit 61 is a bolt-shaped member extending in the width direction as shown in, e.g., FIG. 4(b). Each warping unit 61 may be, e.g., a known full-dog point set bolt. For the sake of convenience, a direction in which each warping unit 61 extends will be referred to as a bolt axial direction. Each warping unit 61 has, e.g., a head 71, a male screw portion 72, and a leading end portion 73. The head 71 is provided on the most base end side in the bolt axial direction of each warping unit 61. The male screw portion 72 is a part of each warping unit 61, which is provided immediately on the leading end side of the head 71 in the bolt axial direction and at which a male screw is formed. The male screw portion 72 is screwed to, e.g., a female screw portion formed at a second heating member 55. With this arrangement, each warping unit 61 is

fixed to the second heating member 55 of the heating unit 41. The leading end portion 73 is a part of each warping unit 61, which is provided immediately on the leading end side of the male screw portion 72 in the bolt axial direction and at which no screw is formed. The leading end portion 73 is provided to overlap, e.g., a housing space 56 in the width direction. With this arrangement, the leading end portion 73 is able to make contact with a part of the yarn contacted member 43 in the extending direction. For example, the warping unit 61C (see FIG. 4(b) and FIG. 5) provided substantially at the center of the first heater 13 in the extending direction is in contact with a first part 43f (see FIG. 4(b); indicated by broken lines in FIG. 5) of the yarn contacted member 43. The first part 43f of the yarn contacted member 43 is provided at the center (predetermined position of the present invention) of the yarn contacted member 43 in the extending direction. With this arrangement, the warping units 61 regulate the movement of some parts of the yarn contacted member 43 which include the first part 43f toward the other side in the height direction (i.e., some parts of the yarn contacted member 43 in the extending direction: hereinafter, these parts will be simply referred to as inner parts for the sake of convenience).

[0056] In the present embodiment, each warping unit 61 is fixed to the second heating member 55 as described above. However, the disclosure is not limited to this. Each warping unit 61 may be fixed to, e.g., a first heating member 54.

[0057] As shown in FIG. 5, for example, the warping units 61 are spaced apart from one another in the extending direction. The positions of each two adjacent warping units 61 are slightly different in the height direction so that the cross sectional curve 59 of a yarn contacted surface 57 has a predetermined curvature. In the present embodiment, each warping unit 61 is immovable with respect to the heating unit 41.

[0058] The hook unit 62 is configured to regulate the movement of a second part 43s (see the hatched part in FIG. 7(a)) of the yarn contacted member 43 toward one side (the working space S side) in the height direction. The second part 43s of the yarn contacted member 43 is provided on one side in the extending direction as compared to the first part 43f of the yarn contacted member 43. The second part 43s is provided at an end portion of the yarn contacted member 43 on one side in the extending direction. This end portion of the yarn contacted member 43 on one side in the extending direction indicates, e.g., a part of (or all of) an area ranging from an end face of the yarn contacted member 43 on one side in the extending direction to a part which is distant from the end face by 10 mm. However, the disclosure is not limited to this. The hook unit 62 is configured to hold the yarn contacted member 43 so that the yarn contacted member 43 is attachable to and detachable from the heating unit 41. As shown in FIGs. 6(a) and 6(b) and FIG. 7(a), for example, the hook unit 62 includes a swing member 81, a swing axis 82 extending along the extending direction,

and a torsion coil spring 83. As the swing member 81 swings about the swing axis 82, the movement of the second part 43s toward one side in the height direction is regulated or allowed.

[0059] The swing member 81 (see FIG. 4(a), FIGs. 6(a) and 6(b), and FIG. 7(a)) is swingably attached to the heating unit 41 through the swing axis 82. The swing member 81 is formed by, e.g., processing a sheet metal. As shown in FIGs. 6(a) and 6(b) and FIG. 7(a), for example, the swing member 81 includes a base portion 84, a stopper 85, and a handle 86. The base portion 84 is a plate provided with an insertion hole (not illustrated) into which the swing axis 82 is inserted.

[0060] The stopper 85 is a plate extending at least radially outward of the swing axis 82 from the base portion 84. The stopper 85 has a claw-shaped contact portion 85b (a second force portion and a second regulatory portion of the present invention) provided with a contact surface 85a which is able to make contact with one end portion of the second part 43s of the yarn contacted member 43 in the height direction. In the height direction, this end portion of the second part 43s is provided on one side in the height direction as compared to its the other end. To be more specific, the contact surface 85a is able to make contact with one end of one regulatory wall 58 in the height direction. In the height direction, this end of the regulatory wall 58 is provided on one side in the height direction as compared to its the other end. The contact portion 85b is movable between an overlapping position (see FIG. 6(a)) which overlaps the yarn contacted member 43 when viewed in the height direction and a retracted position (see FIG. 6(b)) which does not overlap the yarn contacted member 43 when viewed in the height direction. Strictly speaking, the contact portion 85b (the hatched part in FIG. 6(a)) extends from the contact surface 85a toward one side in the height direction when the contact portion 85b is at the overlapping position (i.e., when the contact surface 85a is in contact with the second part 43s). As moving from the retracted position to the overlapping position, the stopper 85 makes contact with a part of one end face of the yarn contacted member 43 in the width direction so that swinging of the stopper 85 is regulated by the yarn contacted member 43. When the yarn contacted member 43 is attached to, e.g., the heating unit 41, the contact surface 85a is provided on the other side in the height direction as compared to an end of the first part 43f on one side in the height direction.

[0061] At one end portion of the contact portion 85b in the height direction, an inclined surface 85c (see FIG. 6(a)) oriented at least toward one side in the height direction is provided. In the height direction, this end portion of the contact portion 85b is provided on one side in the height direction as compared to the other end portion of the contact portion 85b. The inclined surface 85c overlaps a part of the housing space 56 in the width direction. When viewed in the extending direction, the inclined surface 85c is inclined, e.g., toward the center of

the housing space 56 in the width direction and toward the other side in the height direction.

[0062] The handle 86 extends from, e.g., the stopper 85 toward one side in the extending direction. An operator can pinch and use the handle 86 by hand. The handle 86 is provided with, e.g., a fitting hole 86a to which a first arm 83a (described later) of the torsion coil spring 83 is fitted.

[0063] The swing axis 82 is fixed to an end portion of the heating unit 41 on one side in the extending direction. The swing axis 82 is, e.g., provided on the other side (opposite side from the working space S) in the height direction as compared to the housing space 56. The swing axis 82 is configured to swingably support the swing member 81. The axial direction of the swing axis 82 is substantially in parallel to, e.g., the extending direction. To the swing axis 82, the torsion coil spring 83 is attached.

[0064] The torsion coil spring 83 is configured to bias the swing member 81 (including the contact portion 85b) so that the swing member 81 moves from the retracted position to the overlapping position. The torsion coil spring 83 is attached to the swing axis 82. At one end portion of the torsion coil spring 83, the first arm 83a is formed. At the other end portion of the torsion coil spring 83, a second arm 83b is formed. The first arm 83a is fitted to, e.g., the fitting hole 86a of the handle 86 and swingable with the swing member 81. The second arm 83b is fixed to, e.g., the cover member 51 not to be swingable about the swing axis 82. The torsion coil spring 83 is included in a biasing portion of the present invention.

[0065] The hook unit 63 is configured to regulate the movement of a third part 43t (see the hatched part in FIG. 7(b)) of the yarn contacted member 43 toward one side (the working space S side) in the height direction. The third part 43t is provided on the other side in the extending direction as compared to the first part 43f of the yarn contacted member 43. The third part 43t is provided at an end portion of the yarn contacted member 43 on the other side in the extending direction. The end portion of the yarn contacted member 43 on the other side in the extending direction indicates, e.g., a part of (or all of) an area ranging from an end face of the yarn contacted member 43 on the other side in the extending direction to a part which is distant from the end face by 10 mm. However, the disclosure is not limited to this. The hook unit 63 is configured to hold the yarn contacted member 43 so that the yarn contacted member 43 is attachable to and detachable from the heating unit 41. Simply put, the hook units 62 and 63 are provided in a symmetrical manner when viewed in the width direction. Therefore, the hook unit 63 is not detailed. As shown in FIGs. 6(c) and 6(d) and FIG. 7(b), the hook unit 63 includes a swing member 91, a swing axis 92 extending along, e.g., the extending direction, and a torsion coil spring 93.

[0066] The swing member 91 corresponds to the swing member 81. The swing member 91 is swingably attached to the heating unit 41 through the swing axis 92. For example, the swing member 91 includes a base portion

94, a stopper 95, and a handle 96. The stopper 95 has a claw-shaped contact portion 95b (a third force portion and a third regulatory portion of the present invention) provided with a contact surface 95a which is able to make contact with one end portion of the third part 43t of the yarn contacted member 43 in the height direction. In the height direction, this end portion of the third part 43t is provided on one side in the height direction as compared to its the other end portion. The contact portion 95b is movable between an overlapping position (see FIG. 6(c)) which overlaps the yarn contacted member 43 when viewed in the height direction and a retracted position (see FIG. 6(d)) which does not overlap the yarn contacted member 43 when viewed in the height direction. Strictly speaking, the contact portion 95b (the hatched part in FIG. 6(c)) extends from the contact surface 95a toward one side in the height direction when the contact portion 95b is at the overlapping position (i.e., when the contact surface 95a is in contact with the third part 43t). When the yarn contacted member 43 is attached to, e.g., the heating unit 41, the contact surface 95a is provided on the other side in the height direction as compared to the end of the first part 43f on one side in the height direction.

[0067] In the stopper 95, an inclined surface 95c (see FIG. 6(c)) oriented at least toward one side in the height direction is provided on one side in the height direction as compared to the contact surface 95a. The inclined surface 95c overlaps a part of the housing space 56 in the width direction. When viewed in the extending direction, the inclined surface 95c is inclined, e.g., toward the center of the housing space 56 in the width direction and toward the other side in the height direction. The handle 96 is provided with, e.g., a fitting hole 96a to which a first arm 93a (described later) of the torsion coil spring 93 is fitted.

[0068] The swing axis 92 is fixed to an end portion of the heating unit 41 on the other side in the extending direction. The swing axis 92 is, e.g., provided on the other side (opposite side from the working space S) in the height direction as compared to the housing space 56. The axial direction of the swing axis 92 is substantially in parallel to, e.g., the extending direction. The torsion coil spring 93 is configured to bias the swing member 91 (including the contact portion 95b) so that the swing member 91 moves from the retracted position to the overlapping position. The torsion coil spring 93 is attached to the swing axis 92. At one end portion of the torsion coil spring 93, the first arm 93a is formed. At the other end portion of the torsion coil spring 93, a second arm 93b is formed. The first arm 93a is fitted to, e.g., the fitting hole 96a of the handle 96 and swingable with the swing member 91. The second arm 93b is fixed to, e.g., the cover member 51. The torsion coil spring 93 is included in the biasing portion of the present invention, as the torsion coil spring 83 is.

(State Of Yarn Contacted Member Attached To Heating Unit)

[0069] The following will describe the state of the yarn contacted member 43 attached to the heating unit 41 in the first heater 13 (the state of the above-described structure provided for heating one of two yarns Y). When the yarn contacted member 43 is attached to the heating unit 41 and held by the elastic deformation holding unit 60, each of the contact portion 85b of the above-described swing member 81 and the contact portion 95b of the above-described swing member 91 is at the overlapping position (see FIGs. 6(a) and 6(c)). Furthermore, the torsion coil spring 83 biases the swing member 81 toward the overlapping position (toward the left side of the sheet of FIG. 6(a)), and the torsion coil spring 93 biases the swing member 91 toward the overlapping position (toward the right side of the sheet of FIG. 6(c)). Because of this, the yarn contacted member 43 is prevented from dropping from the heating unit 41.

[0070] When viewed in the width direction, the yarn contacted member 43 is attached to the heating unit 41 while being elastically deformed as indicated by solid lines in FIG. 5 on account of the above-described arrangements of the warping units 61 and hook units 62 and 63. To be more specific, the yarn contacted member 43 is warped so that the both end portions of the yarn contacted member 43 in the extending direction are on the other side (opposite side from the working space S) in the height direction as compared to the remaining parts of the yarn contacted member 43. In the yarn contacted member 43 of this case, the center of the first heater 13 in the extending direction and its surrounding portions are provided on one side (the working space S side) in the height direction of the both end portions of the yarn contacted member 43. In this regard, the above-described inner parts of the yarn contacted member 43 in the extending direction are about to be moved toward the other side in the height direction on account of elastic restoring force. However, in the yarn contacted member 43, the movement of some parts in contact with the respective warping units 61 (i.e., the inner parts of the yarn contacted member 43 in the extending direction which include the first part 43f) toward the other side in the height direction is regulated by the warping units 61. With this arrangement, the warping units 61 apply a force toward one side in the height direction (as indicated by arrows directed to the lower side of the sheet of FIG. 5) to these inner parts of the yarn contacted member 43 in the extending direction on account of the law of action and reaction. The second part 43s and third part 43t of the yarn contacted member 43 are about to be moved toward one side in the height direction on account of the elastic restoring force. However, the movement of the second part 43s toward one side in the height direction is regulated by the contact portion 85b of the hook unit 62, and the movement of the third part 43t toward one side in the height direction is regulated by the contact portion 95b of the hook unit 63.

With this arrangement, the hook units 62 and 63 apply a force toward the other side in the height direction (as indicated by arrows directed to the upper side of the sheet of FIG. 5) to the second part 43s and the third part 43t on account of the law of action and reaction. As such, the yarn contacted member 43 is attached to the heating unit 41 while being elastically deformed. With this arrangement, the cross sectional curve 59 (see FIGs. 3(b)) in a cross section orthogonal to the width direction of a yarn contacted surface 57 has a predetermined curvature. The curvature radius of the cross sectional curve 59 is within a range of, e.g., 15 to 20 meters at any part of the cross sectional curve 59. In the extending direction, the curvature radius of the cross sectional curve 59 may be constant at any part of the cross sectional curve 59. However, the disclosure is not limited to this.

(Method Of Attachment And Detachment Of Yarn Contacted Member)

[0071] The following will describe a method of attaching and detaching the yarn contacted member 43 to and from the heating unit 41. To begin with, the following describes a method of detaching the yarn contacted member 43 from the heating unit 41. The movement of the both end portions of the yarn contacted member 43 in the extending direction toward one side in the height direction is allowed in such a way that the operator operates the swing members 81 and 91 of the elastic deformation holding unit 60 to move (swing) each of the contact portions 85b and 95b from the overlapping position to the retracted position. This allows the operator to detach the yarn contacted member 43 from the heating unit 41 by manually moving the yarn contacted member 43 in the housing space 56 toward one side in the height direction (causing the yarn contacted member 43 to pass through the housing space 56). With this arrangement, the cleaning of the yarn contacted member 43 is facilitated. The operator may instantly detach the entire yarn contacted member 43 from the heating unit 41 by moving each of the contact portions 85b and 95b from the overlapping position to the retracted position substantially at the same time. Alternatively, the operator may detach the entire yarn contacted member 43 from the heating unit 41 after moving one of the contact portions 85b and 95b to the retracted position, detaching a part of the yarn contacted member 43 from the heating unit 41, and moving the other of the contact portions 85b and 95b to the retracted position. As detached from the heating unit 41, the yarn contacted member 43 is restored in shape (to be substantially linear: as indicated by two-dot chain lines in FIG. 5) on account of the elastic restoring force.

[0072] The following describes a method of attaching the yarn contacted member 43 to the heating unit 41. The operator inserts the yarn contacted member 43 into the housing space 56 by hand. Subsequently, the operator moves the both end portions of the yarn contacted member 43 in the extending direction toward the other side in

the height direction while pressing the above-described inner parts of the yarn contacted member 43 in the extending direction onto the warping units 61. This starts the elastic deformation of the yarn contacted member 43.

5 The operator then further moves the both end portions of the yarn contacted member 43 in the extending direction toward the other side in the height direction while pressing the yarn contacted member 43 onto the inclined surfaces 85c and 95c. Because of this, as a force against the biasing force of the torsion coil springs 83 and 93, a force is applied to the swing members 81 and 91 to move each of the contact portions 85b and 95b to the retracted position. When the second part 43s and third part 43t of the yarn contacted member 43 are moved toward the other side in the height direction as compared to the contact surfaces 85a and 95a, each of the contact portions 85b and 95b is moved back to the overlapping position from the retracted position on account of the biasing force of the torsion coil springs 83 and 93. As a result, the yarn contacted member 43 is attached to the heating unit 41 while being elastically deformed.

[0073] As described above, the yarn contacted member 43 is elastically deformed by the elastic deformation holding unit 60 and attached to the heating unit 41 so that the cross sectional curve 59 of the yarn contacted surface 57 has a predetermined curvature. In other words, even when the yarn contacted member 43 is produced to linearly extend and is attached to the first heater 13, the yarn contacted surface 57 has a desired shape only in such a way that the yarn contacted member 43 is elastically deformed. As a result, the production cost of the yarn contacted member 43 is reduced as compared to a case where a yarn contacted member (not illustrated) is processed in advance based on the specifications of the first heater 13. It is therefore possible to achieve the reduction in production cost of the yarn contacted member 43 applied to the first heater 13.

[0074] The yarn contacted member 43 is detachable from the heating unit 41 at the time of cleaning. It is therefore possible to improve the work efficiency in cleaning of the yarn contacted member 43, irrespective of the position of the first heater 13.

[0075] The yarn contacted member 43 may be attached to and detached from the heating unit 41 by, e.g., being inserted into and pulled out from the heating unit 41 in the extending direction. In this case, however, a long space provided for the attachment and detachment of the yarn contacted member 43 is required at a position adjacent to the first heater 13 in the extending direction. This puts a large limit on the layout of the first heater 13 and its surroundings. Assume that such a long space at the position adjacent to the first heater 13 in the extending direction is secured. In this case, however, when a regulatory member such as the twist-stopping guide 12 (see FIG. 1) configured to define a yarn path is provided in this space, the following problems may occur. That is, before the yarn contacted member 43 is inserted in or pulled out from the heating unit 41 in the extending direction, a

member such as the twist-stopping guide 12 provided around the first heater 13 needs to be temporarily removed. This increases the burden on the operator. Furthermore, the yarn path defined by the twist-stopping guide 12, etc. may unintentionally change before and after the attachment and detachment of the yarn contacted member 43. In the present embodiment, the yarn contacted member 43 is attachable to and detachable from the heating unit 41 by moving the yarn contacted member 43 in the height direction. With this arrangement, differently from the case where the yarn contacted member 43 is attached to and detached from the heating unit 41 by being inserted in and pulled out from the heating unit 41, the above-described long space at the position adjacent to the first heater 13 in the extending direction is not required. Furthermore, a member provided around the first heater 13 does not need to be removed at the time of attachment and detachment of the yarn contacted member 43. It is therefore possible to suppress the occurrence of disadvantages such as the limit on the layout of the first heater 13 and its surroundings.

[0076] In the present embodiment, a force toward one side in the height direction is applied to a part of the yarn contacted member 43 in the extending direction, and a force toward the other side in the height direction is applied to the both end portions of the yarn contacted member 43 in the extending direction. With this arrangement, the yarn contacted member 43 is warped. It is therefore possible to elastically deform the yarn contacted member 43 with a simple structure.

[0077] The force toward one side in the height direction is applied to the first part 43f on account of the law of action and reaction in such a way that one warping unit 61 regulates the movement of the first part 43f toward the other side in the height direction. The force toward the other side in the height direction is applied to the second part 43s and the third part 43t on account of the law of action and reaction in such a way that the contact portions 85b and 95b regulate the movement of the second part 43s and third part 43t toward one side in the height direction. It is therefore possible to elastically deform the yarn contacted member 43 with a simple structure.

[0078] Each of the contact portions 85b and 95b is movable between the retracted position and the overlapping position. With this arrangement, the yarn contacted member 43 is attached to the heating unit 41 in such a simple way that (i) each of the contact portions 85b and 95b is temporarily moved to the retracted position and then (ii) each of the contact portions 85b and 95b is moved back to the overlapping position while the yarn contacted member 43 is warped. When the yarn contacted member 43 is attached to the heating member 41, the yarn contacted member 43 is detached from the heating unit 41 in such a simple way that each of the contact portions 85b and 95b is temporarily moved to the retracted position.

[0079] The contact portion 85b is biased from the retracted position toward the overlapping position by

the torsion coil spring 83. The contact portion 95b is biased from the retracted position toward the overlapping position by the torsion coil spring 93. This suppresses each of the contact portions 85b and 95b from being unintentionally moved from the overlapping position to the retracted position.

[0080] The swing members 81 and 91 (i.e., the contact portions 85b and 95b) are swingably supported by the respective swing axes 82 and 92. It is therefore possible to downsize a space required for the movement of the contact portions 85b and 95b.

[0081] The following will describe modifications of the above-described embodiment. The members identical with those in the embodiment above will be denoted by the same reference numerals and the explanations thereof are not repeated.

(1) In the embodiment above, the warping units 61 are fixed to the heating unit 41 so as to be immovable with respect to the heating unit 41. However, the disclosure is not limited to this. For example, the warping units 61 may be movable in the extending direction and/or height direction of the heating unit 41 (movable in a parallel manner or swingable). For example, an adjusting member (e.g., unillustrated bolt) may be provided for manually adjusting the position of each warping unit 61. Alternatively, an unillustrated electric actuator may be provided for moving each warping unit 61. In addition to the warping units 61 (or instead of the warping units 61), the entire hook unit 62 and/or the entire hook unit 63 may be movable in the extending direction and/or the height direction. That is, the position of at least one of each warping unit 61, the contact portion 85b, and the contact portion 95b may be changeable with respect to the heating unit 41 in at least one of the extending direction and the height direction. With this arrangement, the curvature of the cross sectional curve 59 of the yarn contacted surface 57 is adjustable according to need even after the first heater 13 is set.

(2) In the embodiment above, each warping unit 61 is a bolt-shaped member extending in the width direction. However, the disclosure is not limited to this. Each warping unit 61 may extend in, e.g., the height direction. Alternatively, each warping unit 61 may not be a bolt-shaped member as long as each warping unit 61 is configured to regulate the movement of the yarn contacted member 43 toward the other side in the height direction. Each warping unit 61 may be, e.g., a plate-shaped member or a block-shaped member. Alternatively, each warping unit 61 may be a spring such as a plate spring configured to apply a force toward one side in the height direction to the yarn contacted member 43. The warping units 61 are attached to the heating unit 41. However, the disclosure is not limited to this. Only one warping unit 61 may be attached to the heating unit 41.

(3) In the embodiment above, the swing members 81 and 91 are biased from the retracted position toward the overlapping position by the respective torsion coil springs 83 and 93. However, the disclosure is not limited to this. Instead of the torsion coil springs 83 and 93, another type of springs such as plate springs may be provided. Instead of the springs, elastic members made of rubber, etc. may be provided. Instead of the elastic members, air cylinders, etc. may be provided. The springs, the elastic members, and the air cylinders also correspond to the biasing portion of the present invention. The biasing portion of the present invention may not be provided. That is, the swing members 81 and 91 may not be biased.

(4) In the embodiment above, the swing member 81 has the inclined surface 85c, and the swing member 91 has the inclined surface 95c. However, the disclosure is not limited to this. Instead of the inclined surfaces 85c and 95c, curved surfaces (not illustrated) may be provided. The curved surfaces are curved when viewed in the extending direction. Alternatively, the inclined surfaces 85c and 95c may not be provided.

(5) In the embodiment above, the swing members 81 and 91 are swingably supported by the swing axes 82 and 92. However, the disclosure is not limited to this. For example, supporters (not illustrated) may be provided to support members shaped in the same manner as the swing members 81 and 91. These members are supported to be movable in a parallel manner in the width direction.

(6) In the embodiment above, the hook units 62 and 63 are provided for the heating unit 41. That is, the contact portions 85b and 95b are configured to apply the force toward the other side in the height direction to the yarn contacted member 43. However, the disclosure is not limited to this. Instead of the hook units 62 and 63, two unillustrated air cylinders or two electric actuators (the second force portion of the present invention or the third force portion of the present invention) may be provided. These air cylinders or electric actuators are configured to apply the force toward the other side in the height direction to the yarn contacted member 43. Alternatively, instead of the hook units 62 and 63, two bolts (not illustrated) functioning in the same manner or a similar manner as the warping units 61 may be provided. In this case, each of the bolts may not be movable between the retracted position and the overlapping position.

(7) In the embodiment above, when the yarn contacted member 43 is attached to or detached from the heating unit 41, the yarn contacted member 43 is able to pass through the housing space 56 in the height direction. However, the disclosure is not limited to this. The yarn contacted member 43 may be attached to and detached from the heating unit 41 by, e.g., being inserted in and pulled out from the heating unit 41 in the extending direction.

(8) In the embodiment above, the yarn contacted member 43 is attachable to and detachable from the heating unit 41 by the elastic deformation holding unit 60. However, the disclosure is not limited to this. For example, the heating unit 41 may be structured so that the yarn contacted member 43 is not detached from the heating unit 41 after it is attached thereto. The yarn contacted member 43 may be provided with an unillustrated screw hole. The heating unit 41 may be structured so that (i) the yarn contacted member 43 is screwed to the heating unit 41 by an unillustrated bolt and (ii) the yarn contacted member 43 is not easily attached to and detached from the heating unit 41. This unillustrated bolt which is used for screwing the yarn contacted member 43 to the heating unit 41 may be fixed to the heating unit 41 by welding. In such a case, a member configured to hold the yarn contacted member 43 while elastically deforming it is equivalent to an elastic deformation holding unit of the present invention.

(9) In the embodiment above, the housing space 56 is formed in the heating unit 41. The housing space 56 is open on one side (the working space S side) in the height direction. However, the housing space 56 and the heating unit 41 may be differently shaped. For example, in a cross section orthogonal to the extending direction, the housing space 56 may be inclined (not illustrated) at 45 degrees or less with respect to the height direction. Alternatively, the housing space 56 in the cross section orthogonal to the extending direction may be substantially L-shaped, i.e., may be open on one side in the height direction and on one of both sides in the width direction (not illustrated). In this case, for example, the yarn contacted member 43 may be attached to and detached from the heating unit 41 through the housing space 56 which is open on one of both sides in the width direction (not illustrated).

(10) In the embodiment above, the heating unit 41 is equivalent to the attaching portion of the present invention. However, the disclosure is not limited to this. For a specific example, an unillustrated heat insulation member, etc. may be provided instead of the second heating member 55. The heat insulation member, etc. is not included in the heating unit 41. In this case, the yarn contacted member 43 is attached to the first heater 13 by being housed in a space (not illustrated) formed by the first heating member 54 and the heat insulation member, etc. A combination of the heating unit 41 and heat insulation member, etc. of this case is equivalent to the attaching portion of the present invention. In other words, the attaching portion of the present invention includes the heating unit 41.

(11) In the embodiment above, the yarn contacted member 43 is formed in such a way that a stainless steel member is cut and processed. However, the disclosure is not limited to this. The yarn contacted

member 43 may be formed by, e.g., bending a plate-shaped member. The material of the yarn contacted member 43 is not limited to stainless steel.

(12) In the embodiment above, the first heater 13 including a sheathed heater as the heat source 42 is provided in the false-twist texturing machine 1. However, the disclosure is not limited to this. Instead of the first heater 13, a known Dowtherm heater configured to heat each yarn contacted member 43 by means of a heating medium may be provided in the false-twist texturing machine 1. In this case, the Dowtherm heater is equivalent to the heater of the present invention. A member (not illustrated) forming a path in which the heating medium is enclosed is equivalent to a heat source of the present invention.

(13) In the embodiment above, the first heater 13 is able to heat two yarns Y. However, the disclosure is not limited to this. The first heater 13 may be able to heat one yarn Y. Alternatively, the first heater 13 may be able to heat three or more yarns Y.

(14) The first heater 13 may be provided not only in the false-twist texturing machine 1 of the present embodiment, but also in a known false-twist texturing machine (not illustrated) which is differently structured. Alternatively, the first heater 13 may be provided not only in a false-twist texturing machine but also in a yarn processor such as a known air texturing machine (not illustrated) configured to process a running yarn (not illustrated).

Claims

1. A heater (13) configured to heat a running yarn (Y), the heater (13) comprising:

a heat source (42);
 a heating unit (41) which extends in a predetermined extending direction and which is heated by the heat source (42);
 a yarn contacted member (43) which has a yarn contacted surface (57), which extends at least in the extending direction, and which is heated by the heating unit (41), the yarn (Y) making contact with the yarn contacted surface (57); and
 an attaching portion (41) which includes the heating unit (41) and to which the yarn contacted member (43) is attached,
 the yarn contacted surface (57) extending at least in the extending direction and being oriented at least to one side in a predetermined height direction orthogonal to the extending direction,
 the heater (13) further comprising an elastic deformation holding unit (60) configured to hold the yarn contacted member (43) attached to the attaching portion (41) while elastically deforming the yarn contacted member (43) viewed in a

width direction orthogonal to the extending direction and the height direction and, when the yarn contacted member (43) is elastically deformed and held by the elastic deformation holding unit (60), a cross sectional curve in a cross section orthogonal to the width direction of the yarn contacted member (57) having a predetermined curvature.

2. The heater (13) according to claim 1, wherein, the elastic deformation holding unit (60) is configured to hold the yarn contacted member (43) so that the yarn contacted member (43) is attachable to and detachable from the attaching portion (41).
3. The heater (13) according to claim 2, wherein, an attachment-detachment path (56) through which the yarn contacted member (43) is able to pass in the height direction at the time of attachment and detachment of the yarn contacted member (43) is formed in the attaching portion (41).
4. The heater (13) according to any one of claims 1 to 3, wherein, the elastic deformation holding unit (60) includes:

a first force portion (61) configured to apply the force toward one side in the height direction to a first part (43f) of the yarn contacted member (43) attached to the attaching portion (41), the first part (43f) being at a predetermined position in the extending direction;

a second force portion (85b) configured to apply the force toward the other side in the height direction to a second part (43s) of the yarn contacted member (43) attached to the attaching portion (41), the second part (43s) being provided on one side in the extending direction as compared to the first part (43f); and

a third force portion (95b) configured to apply the force toward the other side in the height direction to a third part (43t) of the yarn contacted member (43) attached to the attaching portion (41), the third part (43t) being provided on the other side in the extending direction as compared to the first part (43f).

5. The heater (13) according to claim 4, wherein, the first force portion (61) includes a first regulatory portion (61) which is provided on the other side in the height direction as compared to the first part (43f) and which is configured to regulate the movement of the first part (43f) toward the other side in the height direction,

the second force portion (85b) includes a second regulatory portion (85b) which is provided on one side in the height direction as compared

to the second part (43s) and which is configured to regulate the movement of the second part (43s) toward one side in the height direction, and the third force portion (95b) includes a third regulatory portion (95b) which is provided on one side in the height direction as compared to the third part (43t) and which is configured to regulate the movement of the third part (43t) toward one side in the height direction.

6. The heater (13) according to claim 5, wherein, when each of the second regulatory portion (85b) and the third regulatory portion (95b) is viewed in the height direction, the each of the second regulatory portion (85b) and the third regulatory portion (95b) is movable between a retracted position which does not overlap the yarn contacted member (43) and an overlapping position which overlaps the yarn contacted member (43).
7. The heater (13) according to claim 6, further comprising a biasing portion (83, 93) configured to bias the each of the second regulatory portion (85b) and the third regulatory portion (95b) from the retracted position to the overlapping position.
8. The heater (13) according to claim 6 or 7, further comprising a swing axis (82, 92) configured to swingably support the each of the second regulatory portion (85b) and the third regulatory portion (95b).
9. The heater (13) according to any one of claims 5 to 8, wherein, the position of at least one of the first regulatory portion (61), the second regulatory portion (85b), and the third regulatory portion (95b) is changeable with respect to the attaching portion (41) in at least one of the extending direction and the height direction.

Patentansprüche

1. Heizkörper (13), der dazu konfiguriert ist, ein laufendes Garn (Y) zu erhitzen, wobei die Heizvorrichtung (13) umfasst:

eine Wärmequelle (42);
 eine Heizeinheit (41), die sich in eine vorbestimmte Erstreckungsrichtung erstreckt und durch die Wärmequelle (42) erwärmt wird;
 ein Garnkontaktelement (43), das eine Garnkontaktoberfläche (57) aufweist, die sich zumindest in der Erstreckungsrichtung erstreckt, und die durch die Heizeinheit (41) erwärmt wird, wobei das Garn (Y) mit der Garnkontaktoberfläche (57) in Kontakt kommt; und
 einen Befestigungsabschnitt (41), der die Heizeinheit (41) einschließt und an dem das Garn-

kontaktelement (43) befestigt ist, wobei sich die Garnkontaktoberfläche (57) zumindest in die Erstreckungsrichtung erstreckt und zumindest zu einer Seite in einer vorbestimmten Höhenrichtung orthogonal zur Erstreckungsrichtung ausgerichtet ist, wobei der Heizkörper (13) weiter eine Halteeinheit (60) für elastische Verformung umfasst, die dazu konfiguriert ist, das Garnkontaktelement (43) zu halten, das an dem Befestigungsabschnitt (41) angebracht ist, während das Garnkontaktelement (43) in einer Breitenrichtung betrachtet, die orthogonal zur Erstreckungsrichtung und zur Höhenrichtung ist, elastisch verformt wird, und wobei, wenn das Garnkontaktelement (43) elastisch verformt und durch die Halteeinheit (60) für elastische Verformung gehalten wird, eine Querschnittskurve in einem Querschnitt orthogonal zur Breitenrichtung des Garnkontaktelements (57) eine vorbestimmte Krümmung aufweist.

2. Heizkörper (13) nach Anspruch 1, wobei die Halteeinheit (60) für elastische Verformung so konfiguriert ist, dass sie das Garnkontaktelement (43) hält, so dass das Garnkontaktelement (43) an dem Befestigungsabschnitt (41) befestigt und davon gelöst werden kann.
3. Heizkörper (13) nach Anspruch 2, wobei im Befestigungsabschnitt (41) ein Befestigungs-/Ablösepfad (56) ausgebildet ist, durch den das Garnkontaktelement (43) zum Zeitpunkt einer Befestigung und Ablösung des Garnkontaktelements (43) in der Höhenrichtung hindurchgehen kann.
4. Heizkörper (13) nach einem der Ansprüche 1 bis 3, wobei die Halteeinheit (60) für elastische Verformung Folgendes einschließt:

einen ersten Kraftabschnitt (61), der dazu konfiguriert ist, die Kraft in Richtung einer Seite in der Höhenrichtung auf einen ersten Teil (43f) des Garnkontaktelements (43) auszuüben, der an dem Befestigungsabschnitt (41) befestigt ist, wobei sich der erste Teil (43f) an einer vorbestimmten Position in der Erstreckungsrichtung befindet;

einen zweiten Kraftabschnitt (85b), der dazu konfiguriert ist, die Kraft in Richtung der anderen Seite in der Höhenrichtung auf einen zweiten Teil (43s) des Garnkontaktelements (43) auszuüben, der an dem Befestigungsabschnitt (41) befestigt ist, wobei der zweite Teil (43s) im Vergleich zum ersten Teil (43f) auf einer Seite in der Erstreckungsrichtung bereitgestellt ist; und
 einen dritten Kraftabschnitt (95b), der dazu kon-

figuriert ist, die Kraft in Richtung der anderen Seite in der Höhenrichtung auf einen dritten Teil (43t) des Garnkontaktelements (43) auszuüben, der an dem Befestigungsabschnitt (41) befestigt ist, wobei der dritte Teil (43t) im Vergleich zum ersten Teil (43f) auf der anderen Seite in der Erstreckungsrichtung bereitgestellt ist.

5. Heizkörper (13) nach Anspruch 4, wobei der erste Kraftabschnitt (61) einen ersten Regulierungsabschnitt (61) einschließt, der im Vergleich zum ersten Teil (43f) auf der anderen Seite in der Höhenrichtung bereitgestellt ist und der dazu konfiguriert ist, die Bewegung des ersten Teils (43f) in Richtung der anderen Seite in der Höhenrichtung zu regulieren,

der zweite Kraftabschnitt (85b) einen zweiten Regulierungsabschnitt (85b) einschließt, der auf einer Seite in der Höhenrichtung im Vergleich zum zweiten Teil (43s) bereitgestellt ist und der dazu konfiguriert ist, die Bewegung des zweiten Teils (43s) zu einer Seite in der Höhenrichtung hin zu regulieren, und
der dritte Kraftabschnitt (95b) einen dritten Regulierungsabschnitt (95b) einschließt, der auf einer Seite in der Höhenrichtung im Vergleich zum dritten Teil (43t) bereitgestellt ist und der dazu konfiguriert ist, die Bewegung des dritten Teils (43t) zu einer Seite in der Höhenrichtung hin zu regulieren.

6. Heizkörper (13) nach Anspruch 5, wobei, wenn der zweite Regulierungsabschnitt (85b) und der dritte Regulierungsabschnitt (95b) in der Höhenrichtung betrachtet werden, der zweite Regulierungsabschnitt (85b) und der dritte Regulierungsabschnitt (95b) jeweils zwischen einer zurückgezogenen Position, die das Garnkontaktelement (43) nicht überlappt, und einer überlappenden Position, die das Garnkontaktelement (43) überlappt, beweglich ist.
7. Heizkörper (13) nach Anspruch 6, weiter umfassend einen Vorspannabschnitt (83, 93), der dazu konfiguriert ist, den zweiten Regulierungsabschnitt (85b) und den dritten Regulierungsabschnitt (95b) jeweils aus der zurückgezogenen Position in die überlappende Position vorzuspannen.
8. Heizkörper (13) nach Anspruch 6 oder 7, weiter umfassend eine Schwenkachse (82, 92), die so konfiguriert ist, dass sie sowohl den zweiten Regulierungsabschnitt (85b) als auch den dritten Regulierungsabschnitt (95b) schwenkbar stützt.
9. Heizkörper (13) nach einem der Ansprüche 5 bis 8, wobei die Position von mindestens einem des ersten Regulierungsabschnitts (61), des zweiten Regulie-

rungsabschnitts (85b) und des dritten Regulierungsabschnitts (95b) in Bezug auf den Befestigungsabschnitt (41) in mindestens einer von der Erstreckungsrichtung und der Höhenrichtung veränderbar ist.

Revendications

1. Dispositif de chauffage (13) configuré pour chauffer un fil courant (Y), l'appareil de chauffage (13) comprenant :

une source de chaleur (42) ;
une unité de chauffage (41) qui s'étend dans une direction d'extension prédéterminée et qui est chauffée par la source de chaleur (42) ;
un élément en contact avec le fil (43) qui présente une surface en contact avec le fil (57), qui s'étend au moins dans la direction d'extension, et qui est chauffé par l'unité de chauffage (41), le fil (Y) entrant en contact avec la surface en contact avec le fil (57) ; et
une portion de fixation (41) qui inclut l'unité de chauffage (41) et à laquelle l'élément en contact avec le fil (43) est fixé,
la surface en contact avec le fil (57) s'étendant au moins dans la direction d'extension et étant orientée au moins vers un côté dans une direction de hauteur prédéterminée orthogonale à la direction d'extension,
le dispositif de chauffage (13) comprenant en outre une unité de maintien de déformation élastique (60) configurée pour maintenir l'élément en contact avec le fil (43) fixé à la portion de fixation (41) tout en déformant élastiquement l'élément en contact avec le fil (43) vu dans une direction de largeur orthogonale à la direction d'extension et à la direction de hauteur et, lorsque l'élément en contact avec le fil (43) est déformé élastiquement et maintenu par l'unité de maintien de déformation élastique (60), une courbe de section transversale dans une section transversale orthogonale à la direction de largeur de l'élément en contact avec le fil (57) présentant une courbure prédéterminée.

2. Dispositif de chauffage (13) selon la revendication 1, dans lequel, l'unité de maintien de déformation élastique (60) est configurée pour maintenir l'élément en contact avec le fil (43) de sorte que l'élément en contact avec le fil (43) puisse être fixé à et détaché de la portion de fixation (41).
3. Dispositif de chauffage (13) selon la revendication 2, dans lequel une voie de fixation-détachement (56) à travers laquelle l'élément en contact avec le fil (43) peut passer dans la direction de hauteur au moment

de la fixation et du détachement de l'élément en contact avec le fil (43) est formée dans la portion de fixation (41).

4. Dispositif de chauffage (13) selon l'une quelconque des revendications 1 à 3, dans lequel, l'unité de maintien de déformation élastique (60) inclut :

une première portion (61) de force configurée pour appliquer la force en direction d'un côté dans la direction de hauteur à une première partie (43f) de l'élément en contact avec le fil (43) fixée à la portion de fixation (41), la première partie (43f) étant au niveau d'une position prédéterminée dans la direction d'extension ;
une deuxième portion (85b) de force configurée pour appliquer la force en direction de l'autre côté dans la direction de hauteur à une deuxième partie (43s) de l'élément en contact avec le fil (43) fixée à la portion de fixation (41), la deuxième partie (43s) étant prévue sur un côté dans la direction d'extension par rapport à la première partie (43f) ; et
une troisième portion (95b) de force configurée pour appliquer la force en direction de l'autre côté dans la direction de hauteur à une troisième partie (43t) de l'élément en contact avec le fil (43) fixée à la portion de fixation (41), la troisième partie (43t) étant prévue sur l'autre côté dans la direction d'extension par rapport à la première partie (43f).

5. Dispositif de chauffage (13) selon la revendication 4, dans lequel, la première portion (61) de force inclut une première portion (61) de régulation qui est prévue sur l'autre côté dans la direction de hauteur par rapport à la première partie (43f) et qui est configurée pour réguler le mouvement de la première partie (43f) en direction de l'autre côté dans la direction de hauteur,

la deuxième portion (85b) de force inclut une deuxième portion (85b) de régulation qui est prévue sur un côté dans la direction de hauteur par rapport à la deuxième partie (43s) et qui est configurée pour réguler le mouvement de la deuxième partie (43s) en direction d'un côté dans la direction de hauteur, et
la troisième portion (95b) de force inclut une troisième portion (95b) de régulation qui est prévue sur un côté dans la direction de hauteur par rapport à la troisième partie (43t) et qui est configurée pour réguler le mouvement de la troisième partie (43t) en direction d'un côté dans la direction de hauteur.

6. Dispositif de chauffage (13) selon la revendication 5, dans lequel, lorsque chacune de la deuxième portion

(85b) de régulation et de la troisième portion (95b) de régulation est vue dans la direction de hauteur, chacune de la deuxième portion (85b) de régulation et de la troisième portion (95b) de régulation est mobile entre une position rétractée qui ne chevauche pas l'élément en contact avec le fil (43) et une position de chevauchement qui chevauche l'élément en contact avec le fil (43).

7. Dispositif de chauffage (13) selon la revendication 6, comprenant en outre une portion de sollicitation (83, 93) configurée pour solliciter chacune de la deuxième portion (85b) de régulation et de la troisième portion (95b) de régulation depuis la position rétractée vers la position de chevauchement.

8. Dispositif de chauffage (13) selon la revendication 6 ou 7, comprenant en outre un axe de pivotement (82, 92) configuré pour supporter de manière pivotante chacune de la deuxième portion (85b) de régulation et de la troisième portion (95b) de régulation.

9. Dispositif de chauffage (13) selon l'une quelconque des revendications 5 à 8, dans lequel, la position d'au moins une de la première portion (61) de régulation, de la deuxième portion (85b) de régulation, et de la troisième portion (95b) de régulation est modifiable par rapport à la portion de fixation (41) dans au moins une direction parmi la direction d'extension et la direction de hauteur.

FIG.1

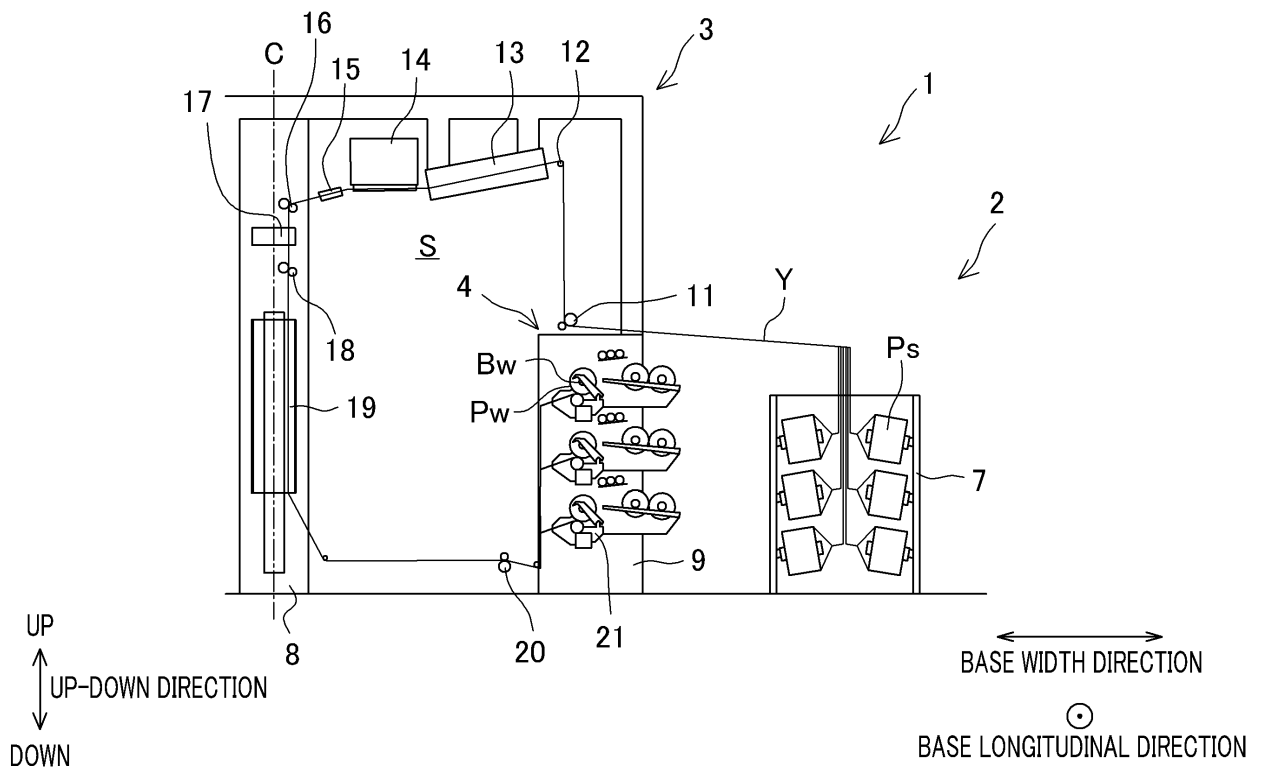

FIG.2

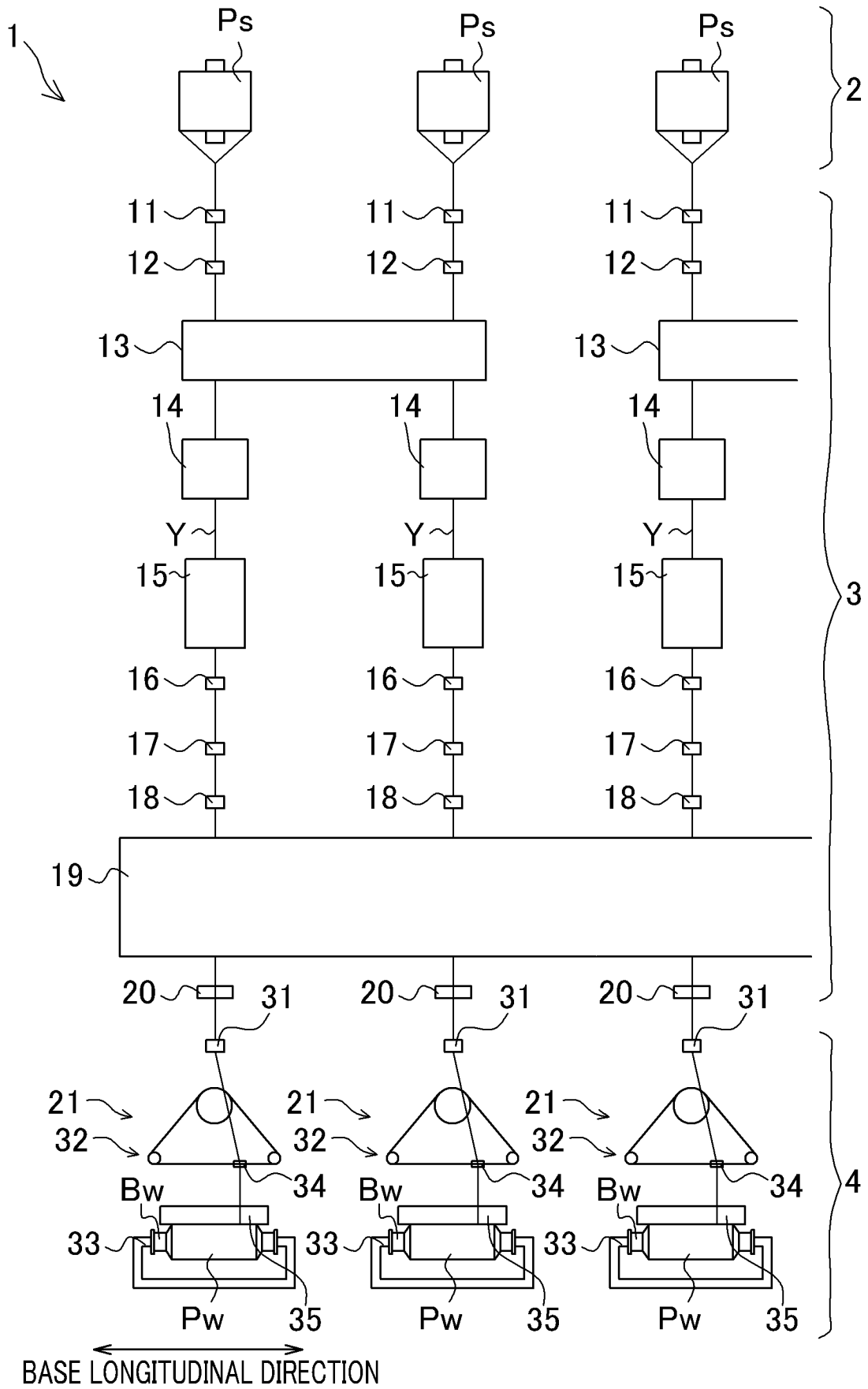

FIG.3

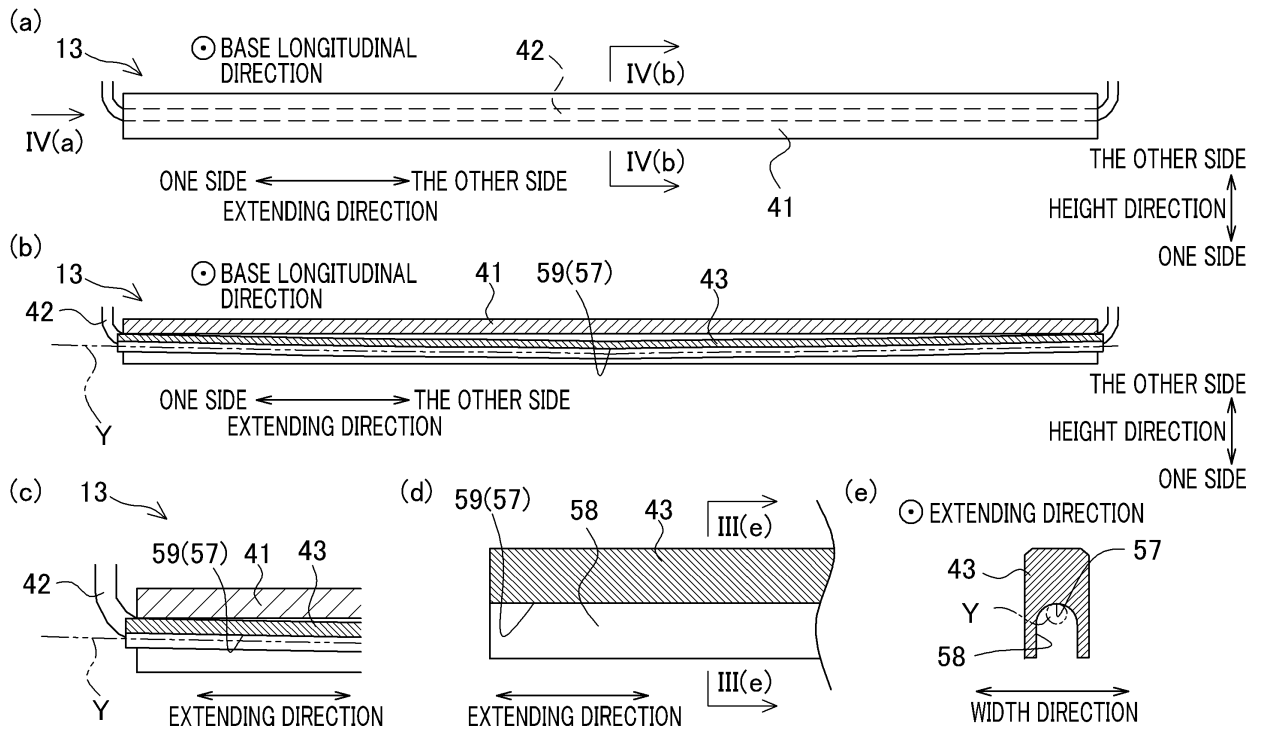

FIG.4

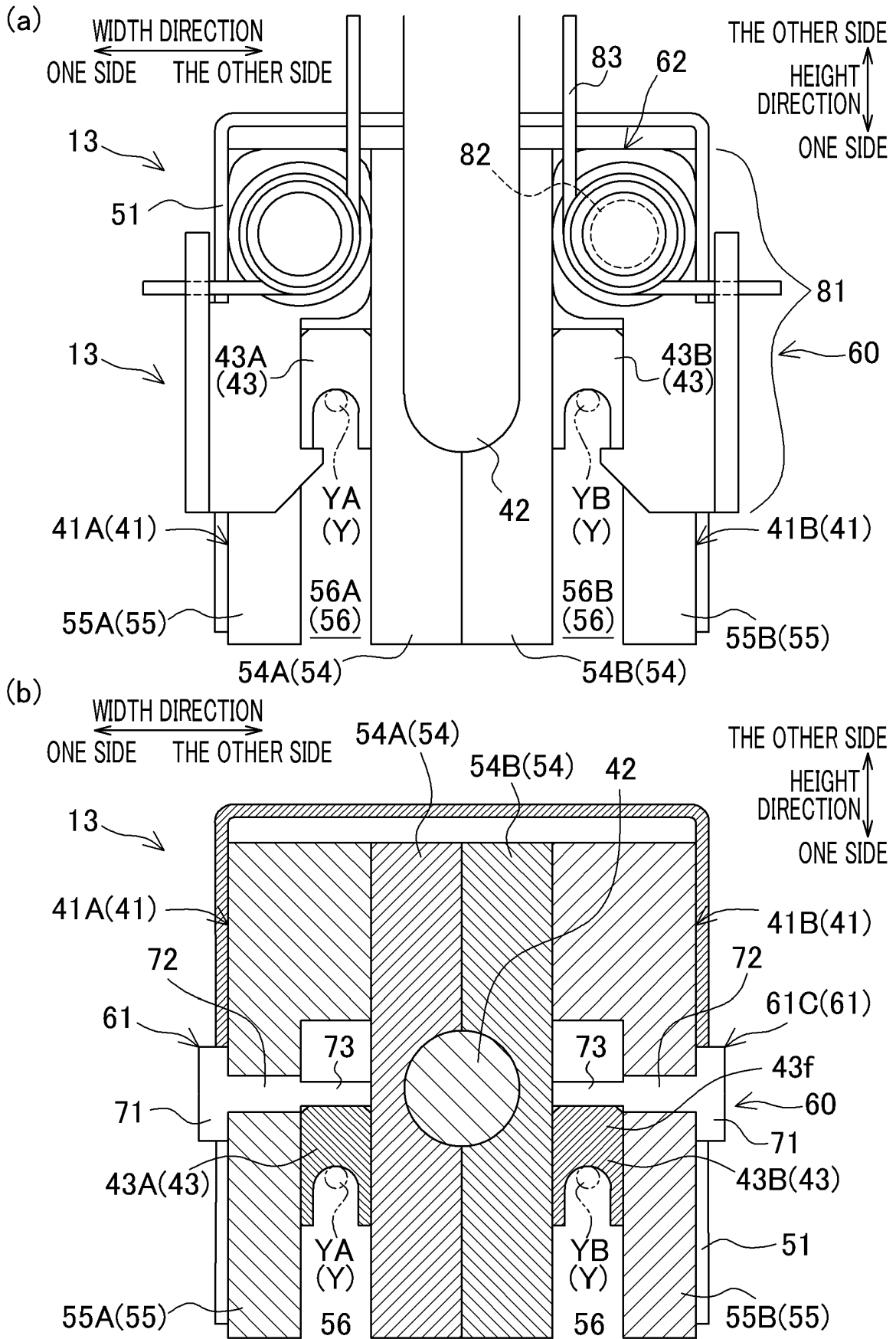

FIG.5

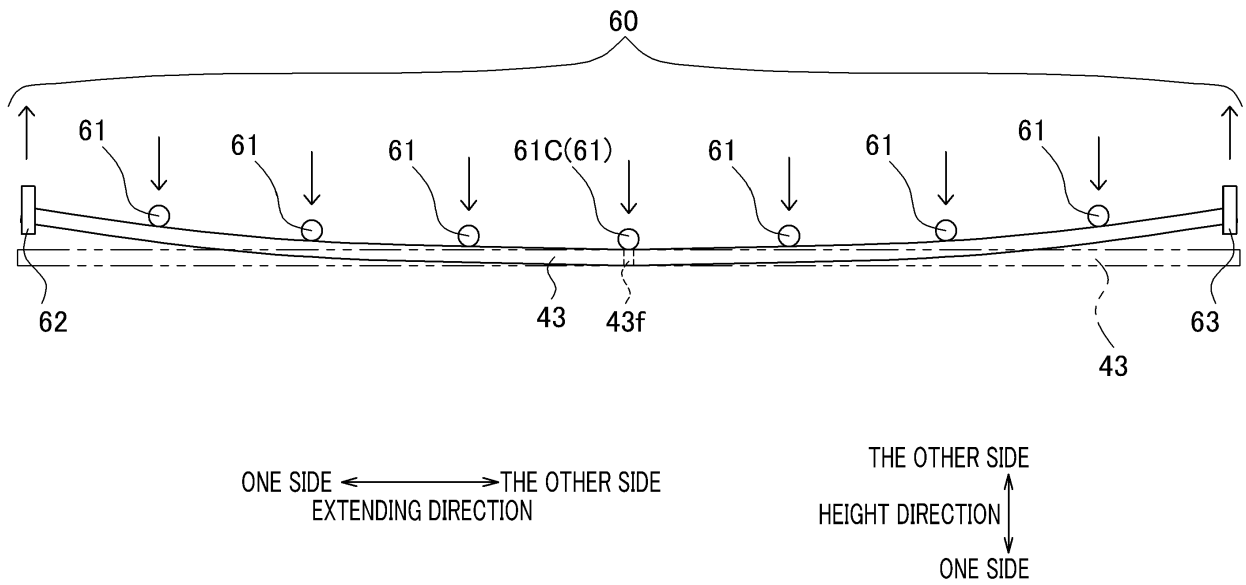

FIG.6

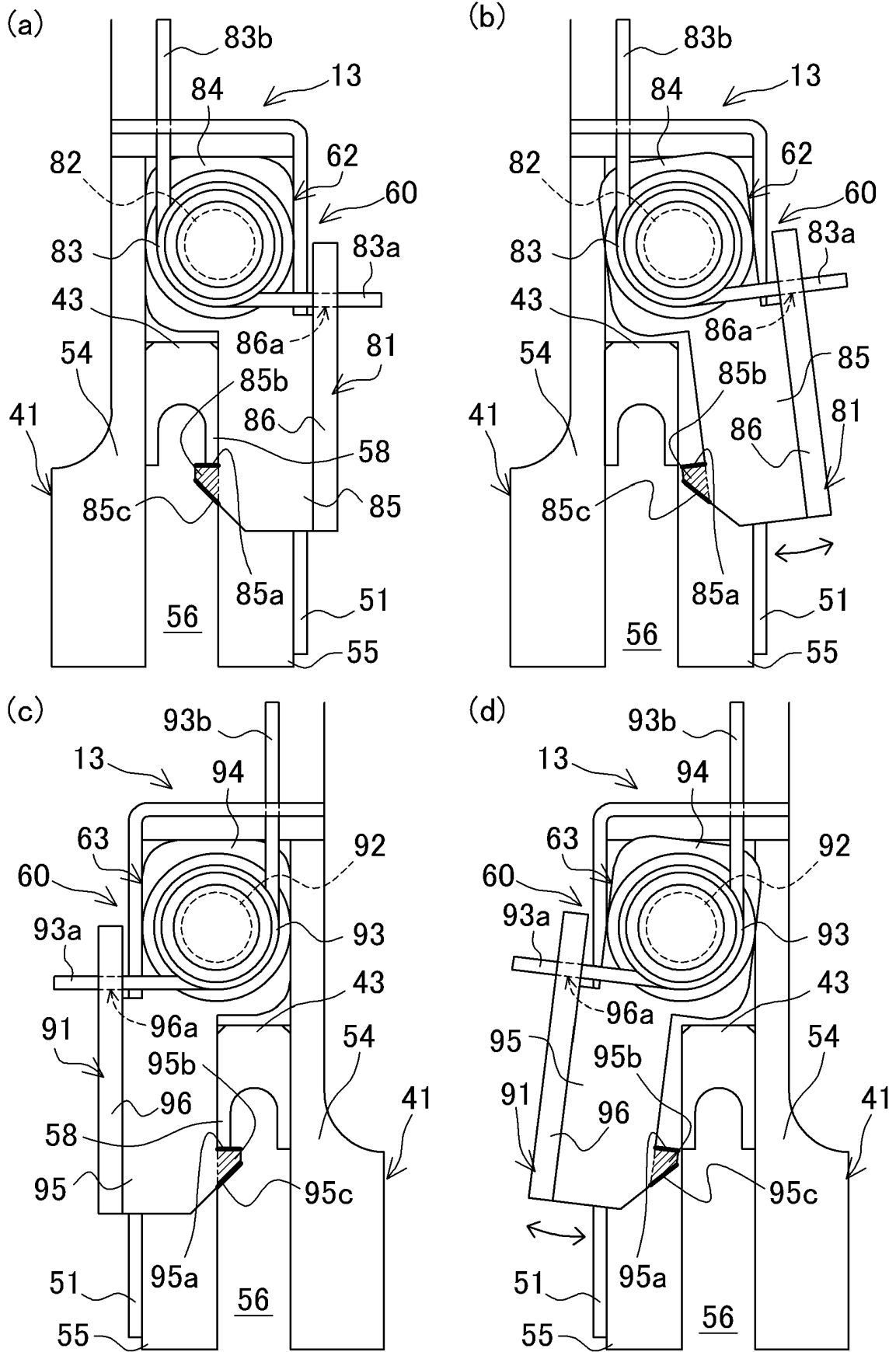
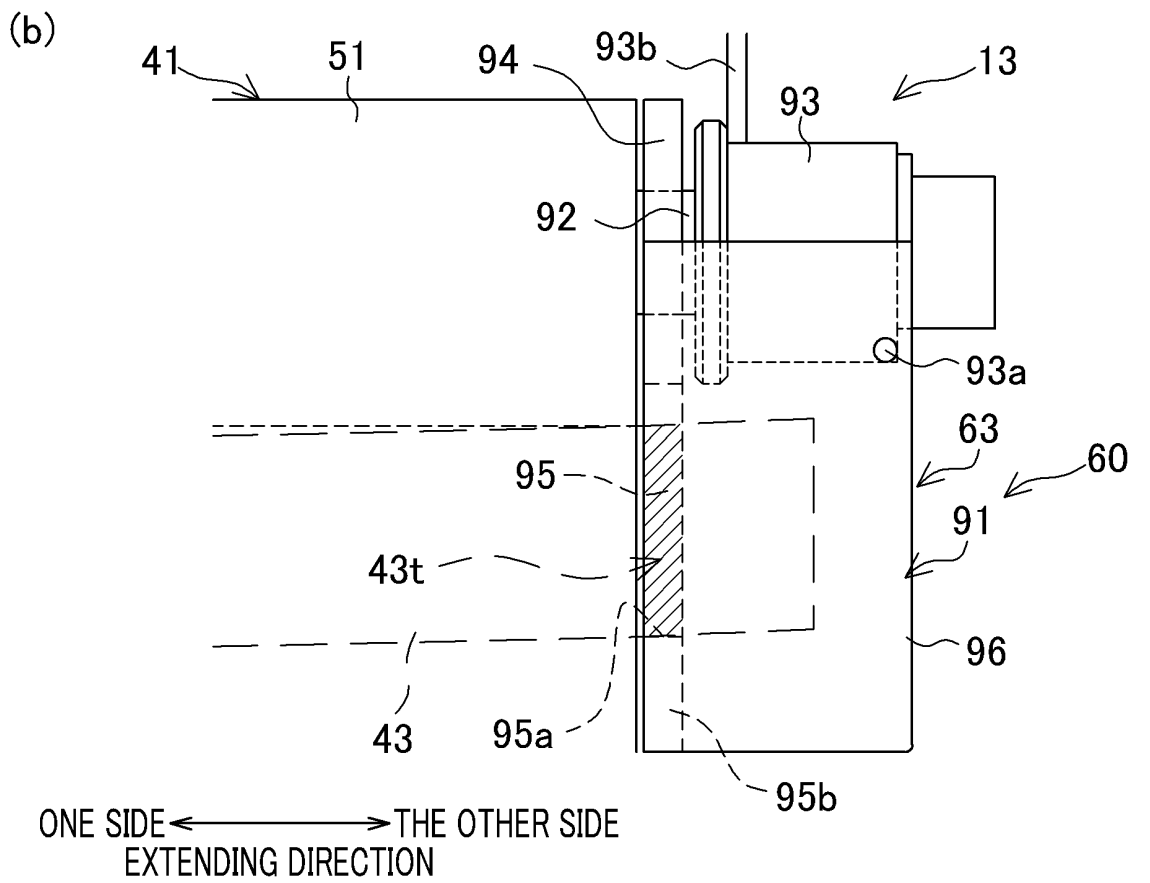
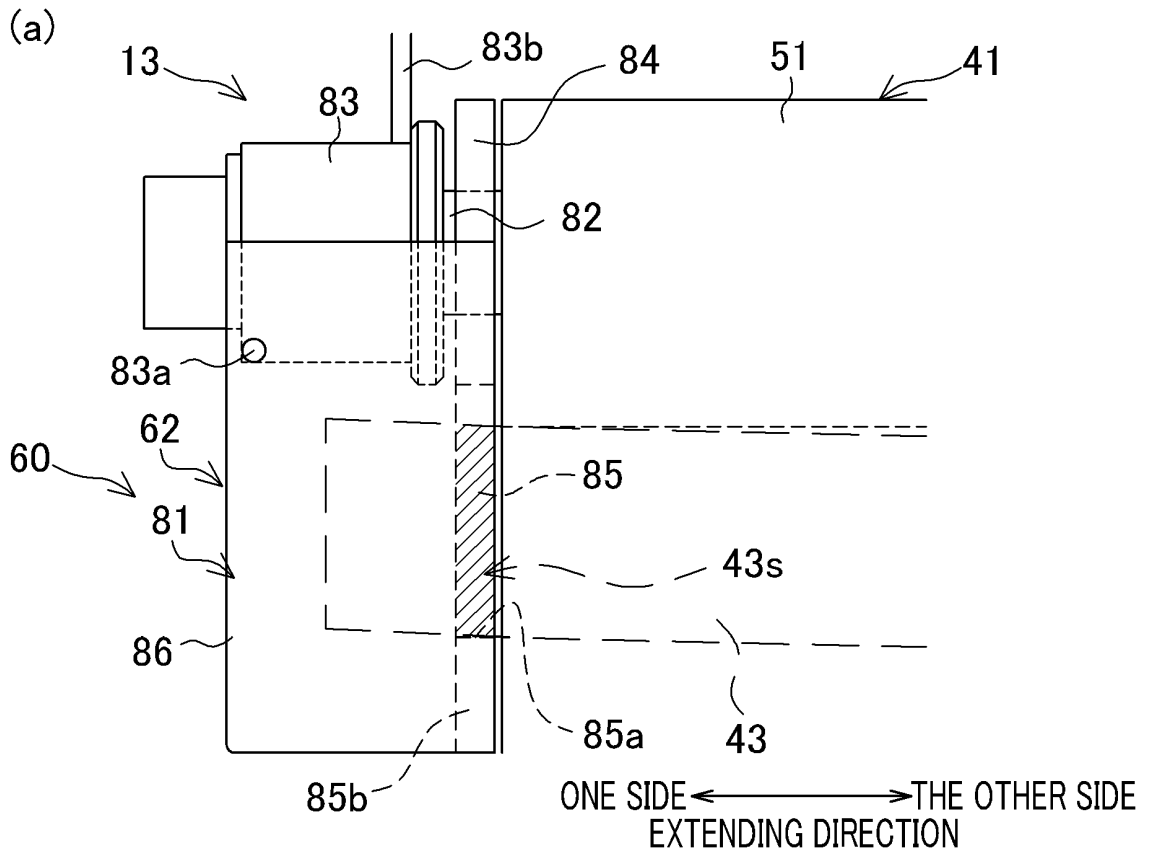

FIG.7



REFERENCES CITED IN THE DESCRIPTION

This list of references cited by the applicant is for the reader's convenience only. It does not form part of the European patent document. Even though great care has been taken in compiling the references, errors or omissions cannot be excluded and the EPO disclaims all liability in this regard.

Patent documents cited in the description

- JP 2002194631 A [0002]
- JP 2006022411 A [0003]
- EP 3210919 A [0003]