



(51) International Patent Classification:

A61B 18/18 (2006.01) A61N 5/02 (2006.01)
A61N 1/40 (2006.01)

(21) International Application Number:

PCT/EP2011/065402

(22) International Filing Date:

6 September 2011 (06.09.2011)

(25) Filing Language:

English

(26) Publication Language:

English

(30) Priority Data:

1439/10 6 September 2010 (06.09.2010) CH

(71) Applicant (for all designated States except US): IT'IS Foundation [CH/CH]; Foundation for Research on Information Technologies in Society, Zeughausstrasse 43, CH-8004 Zürich (CH).

(72) Inventors; and

(75) Inventors/Applicants (for US only): CAPSTICK, Myles [GB/CH]; Foundation for Research on Information, Technologies in Society (IT'IS Foundation), Zeughausstrasse 43, CH-8004 Zürich (CH). KUSTER, Niels [CH/CH]; Foundation for Research on Information, Technologies in

Society (IT'IS Foundation), Zeughausstrasse 43, CH-8004 Zürich (CH). KUEHN, Sven [DE/CH]; Foundation for Research on Information, Technologies in Society (IT'IS Foundation), Zeughausstrasse 43, CH-8004 Zürich (CH). NEUFELD, Esra [CH/CH]; Foundation for Research on Information, Technologies in Society (IT'IS Foundation), Zeughausstrasse 43, CH-8004 Zürich (CH).

(74) Agent: SCHÖN, Christoph; Bavariaring 26, 80336 Munich (DE).

(81) Designated States (unless otherwise indicated, for every kind of national protection available): AE, AG, AL, AM, AO, AT, AU, AZ, BA, BB, BG, BH, BR, BW, BY, BZ, CA, CH, CL, CN, CO, CR, CU, CZ, DE, DK, DM, DO, DZ, EC, EE, EG, ES, FI, GB, GD, GE, GH, GM, GT, HN, HR, HU, ID, IL, IN, IS, JP, KE, KG, KM, KN, KP, KR, KZ, LA, LC, LK, LR, LS, LT, LU, LY, MA, MD, ME, MG, MK, MN, MW, MX, MY, MZ, NA, NG, NI, NO, NZ, OM, PE, PG, PH, PL, PT, QA, RO, RS, RU, RW, SC, SD, SE, SG, SK, SL, SM, ST, SV, SY, TH, TJ, TM, TN, TR, TT, TZ, UA, UG, US, UZ, VC, VN, ZA, ZM, ZW.

(84) Designated States (unless otherwise indicated, for every kind of regional protection available): ARIPO (BW, GH,

[Continued on next page]

(54) Title: ELECTROMAGNETIC FIELD APPLICATOR ARRAY WITH INTEGRAL FIELD SENSORS FOR IMPLICIT CORRECTION OF MUTUAL COUPLING AND MISMATCH

Fig. 5

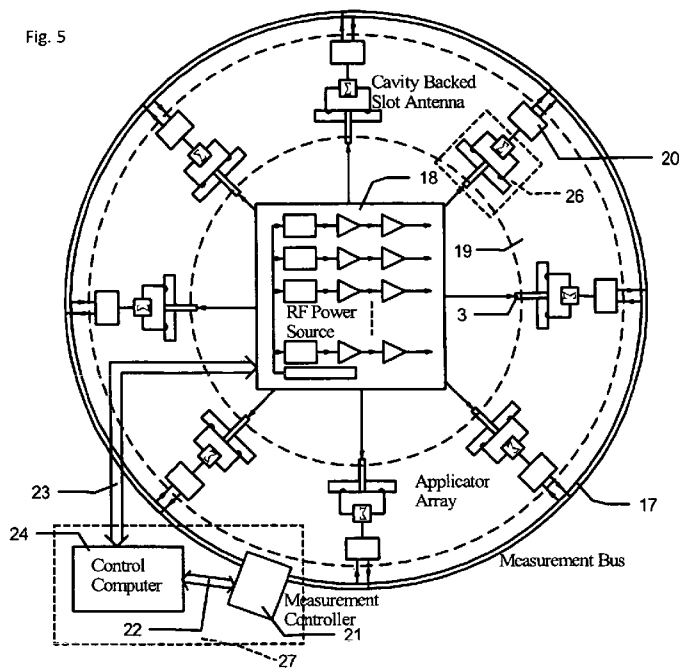

(57) Abstract: The invention concerns a system for producing specific field distributions in a defined volume or region. The system comprises an array of electromagnetic field generating elements each with an integrated sensor for measuring the phase and amplitude of the current flowing in a metallic element (antenna or coil) or field in a slot based element, a measurement device to enable measurement of both phase and amplitude of the electrical signals from the sensors with sufficient dynamic range for quantification of the signal, a multi channel radio frequency power source with individually controllable amplitude and phase to excite each of the electromagnetic field generating elements, and a feedback controller enabling controlled adjustment of the amplitude and phase of the radio frequency power source based on the signals from the sensors. The system controls the outputs of a multi channel radio frequency power source such that the current in a metallic or the field in a slot based electromagnetic field generating elements provide the desired electromagnetic field values and the superposition of the fields produced by each electromagnetic field generating element produces said specific electromagnetic field distribution in said defined volume or region. As the signal picked up by each sensor is directly related to the phase and amplitude of the current or field in the associated electromagnetic field generating element

and hence the electromagnetic field generated by the array elements, where the current or field measured is the sum of both the applied (from the radio frequency power source) and secondary excitations from mutual coupling and reflections hence the measured value represents the ideal excitation in the absence of mutual coupling, reflections and mismatch. The feedback controller modifies the direct excitation such that the total excitation is the ideal array excitation without coupling or mismatch. The invention implicitly corrects for the coupling and mismatch without explicit knowledge of, and calculation based on, the mutual coupling and mismatch, termed the coupling matrix, such that changes in the coupling

[Continued on next page]

WO 2012/032053 A1



GM, KE, LR, LS, MW, MZ, NA, SD, SL, SZ, TZ, UG, ZM, ZW), Eurasian (AM, AZ, BY, KG, KZ, MD, RU, TJ, TM), European (AL, AT, BE, BG, CH, CY, CZ, DE, DK, EE, ES, FI, FR, GB, GR, HR, HU, IE, IS, IT, LT, LU, LV, MC, MK, MT, NL, NO, PL, PT, RO, RS, SE, SI, SK, SM, TR), OAPI (BF, BJ, CF, CG, CI, CM, GA, GN, GQ, GW, ML, MR, NE, SN, TD, TG).

— of inventorship (Rule 4.17(iv))

Published:

— with international search report (Art. 21(3))

— before the expiration of the time limit for amending the claims and to be republished in the event of receipt of amendments (Rule 48.2(h))

Declarations under Rule 4.17:

matrix due to presence of objects or changes thereof are inherently taken into account. Additionally, by sequentially exciting each element in turn the invention can directly determine the exact mutual coupling matrix of the array even in the presence of variations in source impedance and undefined cable lengths such that initial excitation amplitudes and phases can be calculated to allow rapid adjustment to the desired values. A particular application of interest is in radio frequency hyperthermia applicator systems.

ELECTROMAGNETIC FIELD APPLICATOR ARRAY WITH INTEGRAL FIELD SENSORS FOR IMPLICIT CORRECTION OF MUTUAL COUPLING AND MISMATCH

Background of the invention

This invention relates to systems for creating specific electromagnetic field conditions within specific regions in space, or for focussing electromagnetic energy into dielectric objects with enhanced control.

The ability to create specific electromagnetic field conditions is a core requirement in many medical applications from imaging to therapies. The present invention has applications in both these disciplines, as well as in phased array technology employed for communications and sensing applications.

One application of this invention is the generation of specific field conditions at certain locations in the human body for the purpose of hyperthermia.

The National Cancer Institute of the US National Institutes of Health defines Hyperthermia (also called thermal therapy or thermotherapy) as a type of cancer treatment in which body tissue is exposed to high temperatures (up to 45°C). Research has shown that high temperatures can damage and kill cancer cells, usually with minimal injury to normal tissues. By killing cancer cells and damaging proteins and structures within cells, hyperthermia may shrink tumors.

This invention is concerned with local hyperthermia in which heat is applied to a small region, such as a tumor. It is possible to use various techniques to deliver energy to heat the tumor. In the context of this invention, either microwave or radio frequencies may be employed to apply the heat. Depending on the tumor location, there are several approaches to local hyperthermia. In the present case, an external approach is employed to treat tumors. The energy is applied by means of an applicator. The applicator is made up of a number of elements that are positioned around or near the appropriate region, and energy is focused on the tumor to raise its temperature using phased array techniques.

Hyperthermia is often applied in combination with other therapies such as radiation therapy and/or chemotherapy. Hyperthermia has been performed as part of the treatment of many types of cancer, including sarcoma, melanoma, and cancers of the head and neck, brain, lung, esophagus, breast, bladder, rectum, liver, appendix, cervix, and peritoneal lining (mesothelioma).

A phased array antenna is an antenna made up from a number of small(er) radiating elements, each with its own feed point. Phased array antennas are electrically steerable, which means the physical antenna can be stationary yet the antenna pattern can be manipulated by adjusting the amplitude weighting and phases of each element such that it is focused towards a particular region or such that it enables location of objects in space. Phased arrays can also be utilized to generate specific field conditions at certain locations in space or to focus radio frequency (RF) energy into dielectric objects in order to elevate the temperature of a target region inside the dielectric object or patient or induce fields and currents in a patient to excite atoms, nerves or other cellular mechanisms.

A phased array can be used for hyperthermia by focusing RF energy into the patient such that the temperature is elevated. When a phased array is used for this purpose, it is termed an applicator as it applies energy to the patient. The phased array or applicator elements are fed by a multi-channel RF or microwave power source where the phase and amplitude signals are agile such that the RF or microwave energy can be focused in a target region or tumor. The number of array elements and placement of these elements with respect to the target region define the quality of the focus that can be achieved.

The exemplar of RF hyperthermia will be used to illustrate the benefits of the invention. Although many systems have been proposed and used in the past for hyperthermia treatment of tumors, either alone or in conjunction with other therapies, the consistency and quality of the treatment has generally been lacking. Of utmost importance in local hyperthermia is the ability to apply or focus the energy from the applicator into the target region, tissue or tumor. To achieve satisfactory treatment outcomes, the whole target region should be heated sufficiently. To ensure this, a good electromagnetic applicator and patient specific models are most preferably used to plan and optimize the treatment. This step of accurately predicting the deposition of energy (and/or temperature rises) and optimizing such for best tumor treatment has been lacking in hyperthermia systems and has contributed to poor outcomes. During the treatment itself, in which RF or microwave power is applied to the hyperthermia array with the excitation amplitudes and phases as determined from the treatment plan, it is essential from a quality assurance point of view that the electromagnetic fields generated by each element is monitored to determine that the correct planned treatment is actually being applied.

Common to all phased array antennas or hyperthermia applicators, is the requirement for a multi-channel source which can generate powerful signals with accurately controllable amplitude and phase with which to feed the individual electromagnetic field generating elements. It is not important for this invention which method is used to generate these signals.

Multi-element or phased array applicators generally dispose the elements of the array around the patient with a water bolus filling the space between patient and array to provide surface cooling and lower reflections at the patient interface. US patents 4672980, 5251645 and 5441532 all show typical phased array applicators. Each has the elements disposed in a circular array around the patient with the individual antenna elements (or pairs of elements in US patent 4672980) excited by an RF power source with controlled amplitude and phase. None of these systems measure the actual applied signals or any power reflected which would reduce the effective radiated power. These factors therefore increase the uncertainty, In US patents 5251645 and 5441532, field sensors are placed in and around the body of the patient to measure the overall applied field at those points and claims that using the values from these sensors the array excitation can be controlled such that the energy is focused into the target. US patent 4672980 uses a different approach where temperature measurement catheters are inserted into the patient and the system controlled to maximize the temperature increase in the target region. The draw-back of both approaches is that the human body is highly inhomogeneous and there is no intuitive relationship between applied excitations of the array and the energy deposition pattern. In essence these approaches assume that knowing the field or temperature at a few points is a substitute for knowing the radiation from each array element.

In the literature, Paulides et al 2007 describe a typical state of the art system, where the magnitude and phase of the applied signals to each applicator element is measured along with the reflected power, such that the control values can be adjusted such that the applied signals in light of reflections are as desired. When used with proper treatment planning this system has the potential to perform satisfactorily. However, the system relies on a computer simulation model fully defining the actual device and no means is available to fully account for changes in registration of the patient with respect to the applicator for the element impedance and mutual coupling element of the excitation.

In the broader context of phased arrays for other applications, US Patent 5867123 uses a technique of exciting single elements and observing the signals received by adjacent elements for built-in testing and failure analysis. Fulton and Chappell, 2009, review different calibration techniques for phased arrays and states arrays should be calibrated in an anechoic environment to determine the coupling matrix to enable compensation of the mutual coupling in the array. Additionally, it is noted that internal electronic hardware can be introduced for the monitoring of any changes from the initial calibrated coupling or transmit chain gains allowing correction to be applied. Lee et al, 1992/3, introduced a transmission (microstrip) line into the antenna panel to couple with each element so that transmit and receive functions of the electronics could be tested. The transmission line receives energy from all elements or injects energy into all elements of the array simultaneously.

Summary of the invention

Experience with radio frequency hyperthermia treatments and treatment planning and knowledge of the short-comings of systems of the nature discussed above, has led to important developments being made to the equipment and control systems. These developments greatly enhance certainty and consistency through assured field excitation. The present invention enhances consistency through assured field excitation from each antenna element of the array in the presence of mutual coupling, mismatch and reflections and hence uncertainty is reduced. Furthermore, the invention allows the coupling matrix to be determined more accurately than by the use of impedance or scattering matrix measurements, enabling a form of self-calibration which may be performed for each patient undergoing treatment. The key to achieving assured field excitation as determined by the treatment plan is the inclusion of sensors integrated into the antenna elements themselves which measure the phase and amplitude of current flowing in a metallic element or field in a slot-based element. These sensors, in the absence of mutual coupling or reflections, provide a measure proportional to the excitation. However, there is no requirement to consider mismatch or phase differences in connection leads, since it is the actual current (or field) in the antenna that is measured. With mutual coupling and reflections, the sensors measure the sum of all excitations, whatever their origin, and hence allows determination of the actual radiated field. Excitation of each element in turn and the measurement of the current (or field) in the excited antenna along with coupled excitation of all other antennas will allow the coupling matrix of the array to be directly determined.

US Patent 5867123 discussed above also excites each element in turn, but does not use this as a means to achieve self-calibration; even if it did, element mismatch would increase uncertainty. Lee et al, 1992/3 includes transmission lines introduced into the antenna panel, but lacks the ability to sense each antenna element individually, and does not disclose any motivation or ability to determine the antenna currents (or fields) due to either direct excitation or mutually coupled excitation. Hence, this system is used as a diagnostic tool rather than for control of field excitation.

The present invention comprises an array of electromagnetic field generating elements and integrates into each a sensor for measuring the phase and amplitude of the current flowing in a metallic element (antenna or coil) or field in a slot based element linked to a measurement device to enable measurement of both phase and amplitude of the electrical signals from each of the sensors, Furthermore, because signal picked up by each sensor is directly proportional to the phase and amplitude of the current or field in the associated electromagnetic field generating element where the current or field is the total current or field whose amplitude and phase is the sum of both the applied (from the radio frequency power source) and secondary excitations from mutual coupling

and mismatch, hence the measured value represents the ideal excitation in the absence of mutual coupling and mismatch. This invention then uses embedded sensors in the antenna to add further functionality, for example, the direct excitation of each array element by a multichannel radio frequency or microwave power source, with individually controllable amplitude and phase, can be modified using a feedback controller such that the total excitation as measured by the embedded (current in a metallic or the field in a slot based antenna) sensor is the ideal array excitation without coupling or mismatch such that the superposition of the fields produced by each electromagnetic field generating element produces a specific electromagnetic field distribution in a defined volume or region. Implicitly correcting for the mutual coupling and mismatch without explicit knowledge of, and calculation based on, the mutual coupling and mismatch, termed the coupling matrix, such that changes in the coupling matrix due to presence of objects or changes thereof are inherently taken into account. Additionally, using sequential excitation of each element, the invention can directly determine the exact mutual coupling matrix of the array even in the presence of variations in source impedance and undefined cable lengths which can be useful in determining the initial excitation of the array of electromagnetic field generating elements such that feedback can more rapidly achieve the predefined ideal array excitation.

Brief Description of accompanying Drawings

Fig. 1: is illustrative of two adjacent array elements (cavity backed slots) one showing the incorporation of one possible implementation of the present invention

Fig. 1a Two adjacent array elements (cavity backed slots), with the cavity screening of one element cut away

Fig. 2: is illustrative of a whole RF hyperthermia applicator phased array, detail of small sensor elements not included

Fig. 3. Multi-channel radio frequency power source

Fig. 4. Measurement Device, single channel

Fig. 5: is illustrative of a whole system with phase and amplitude controlled multi-channel transmitter and phase/amplitude detectors connected by a measurement bus to the measurement and computer controllers.

Fig. 6. is illustrative of an array for radio frequency hyperthermia in which a water bolus is shown for placement between the array elements and the patient to reduce reflection and facilitate surface cooling.

Technical Description with reference to accompanying Drawings

The invention relates to a system made up of five integral parts, it is the novel features of some of these parts and the integration and use of them as a whole that provides the innovation. The first integral part are the electromagnetic field generating elements, figure 1, which are arranged into an array of arbitrary geometry, figure 2. The array of elements is connected to a radio frequency power source, figure 3, which has a number of independently phase and amplitude computer controllable channels. Integrated into each electromagnetic field generating element is a current (or field) sensing element which produces an electrical output proportional to the electromagnetic field generated, each electrical signal is measured by a measurement device that measures both amplitude and phase, figure 4. The measurement data is communicated via a measurement bus to a measurement controller. A control computer utilizes the measurement data to control the radio frequency power source in such a way that the electromagnetic fields generated are the required fields, the whole system and the interconnections are shown in figure 5.

An illustrative application of the invention is a phased array 19 applicator system, figure 5, that can generate specific field conditions at certain locations in space or focus the RF energy into dielectric objects. The direct measurement of the currents or fields in metallic, slot or coil elements 26 allows direct quantification of the radiated or reactive fields generated by the electromagnetic field generating elements. More specifically, the invention provides the possibility to implicitly correct for the perturbations in the electromagnetic field generated due mutual coupling and mismatch in the applicator array 19 without explicitly measuring the coupling matrix and applying a correction to the excitations from the a radio frequency power source 18. The direct relationship between the current in a metallic element (or field in a slot based element) to the electrical output from the element sensors 4 to the radiated or reactive field can be determined by experimental or numerical means.

An objective of the invention is to provide an improved means of determining the actual radiated or reactive near field of each element 26, figure 1, in an array of electromagnetic field generating elements 19 for radio frequency hyperthermia applications, figures 2 and 6, where the immediate load due to patient, dielectric objects and other system components changes the coupling between

and matching seen at the input ports 3 of the elements 26 or where the source impedance of the radio frequency power source channels 11 are not well characterized.

A further objective of the invention is to provide higher levels of confidence that the real array excitation from the multichannel radio frequency power source 18 is the planned excitation ensuring higher quality control of the field distribution generated by the array 19 of electromagnetic field generating elements. To enable this, the electromagnetic field generated is measured, figure 4, using a measurement device such as a vector volt meter or in-phase/quadrature demodulator of sufficient sensitivity. Additional circuitry may be added, as shown in figure 4, to allow self calibration of the amplitude and phase detectors facilitated by not only distributing the local oscillator via a bus but also a phase reference which can be switched to the input to allow calibration and / or phase ambiguity removal further reducing the uncertainty.

Additionally, the invention provides a new paradigm for the correction of array mutual coupling by implicitly measuring the generated electromagnetic field with the mutual coupling and mismatch accounted for. Hence the actual and planned excitations have a low deviation in particular in the presence of variations that could not be modeled during treatment planning.

Furthermore, the invention does not limit the geometry or placement of the applicator array elements 26, figure 2, around or close to the target area and can be applied to any generic array of electromagnetic field generating elements 19. In particular there are no limits on the proximity of dielectric objects such as patients or other mutual coupling or element matching modifying attributes.

Though the integrated current or field sensors 4, figure 1, implicitly take into account mismatch and mutual coupling, the invention allows the coupling matrix (that describes the mismatch and mutual coupling) of the applicator array of electromagnetic field generating elements to be directly determined with greater accuracy than the standard technique of calculating the coupling matrix from the S-parameters and with the convenience of not having to disconnect the applicator array 19 from the radio frequency power source 18, figure 5, and connect it to a network analyzer. By excitation of each element 2 in turn using the radio frequency power source and measurement of the requisite currents (or fields) 5 in all the elements 2 using the measurement device 18 the coupling matrix can be determined more accurately as the non-ideal output impedances of each amplifier 10 and connecting cable lengths between radio frequency power source output 11 and electromagnetic field generating element 3 are inherently accounted for.

The invention whilst providing this very important information on the radiated or reactive field from each element 26 also gives the ability to detect which output channel 11 from the multi channel

radio frequency power source 18 has been connected to which electromagnetic field generating element 26 in the array 19 and hence remove the possibility of incorrect connection and the chance of a treatment that is completely in error.

With a measurement device 20 integrated with each element 26 it becomes possible to have an individual identity for each electromagnetic field generating element allowing individual calibrations for the element – measuring device combination to be assigned. Therefore, calibration data can be assigned to the correct element for means of quality control, ease of use and security. A calibration facility can therefore provide an accredited calibration that can be attributed to a given element. Enabling the whole array 19 to be modular with replaceable elements 26 and provide 'plug and play' capabilities.

Description of the preferred embodiment

The preferred embodiment can be described in the context of an RF hyperthermia applicator system, figures 5. This hyperthermia applicator system consists of both hardware and a computer control systems and these systems allow enhanced use paradigms that illustrate the utility of the invention.

The Hyperthermia applicator system illustrated in figure 5 takes the form of a ring array applicator made up of electromagnetic field generating elements, figure 2, where the electromagnetic field generating elements, figure 1, are placed around the body in the vicinity of the region to be heated. It is not always the case that elements need to form an entire ring, but might be placed predominantly on one side of the patient. In this specific array however the E-field vector of all elements should be predominantly aligned in the same direction within the target region, but this is not a requirement in all applications of the system. The region between the applicator and the patient is filled by a water bolus, figure 6, of a defined shape which affords three things:

1. Miniaturization of the antenna elements due to the high dielectric constant.
2. Minimization of the discontinuity between antenna and patient as the dielectric properties of water and tissue are much more similar than air and tissue.
3. To provide cooling of the patient skin as high levels of specific energy absorption can occur on the body surface.

Cavity backed slot antennas, figure 1, are chosen as the electromagnetic field generating elements in our preferred embodiment as they provide: Low profile, good polarization purity, accurate dimensions through photolithographic printed circuit processing techniques, ease of manufacture, robust structure, relatively broadband response and hence tolerance to environment changes. With

a slot antenna 2 embodiment then an appropriate method of sensing is through sensing of the field in the slot by means of small coupling loops 4. The loops 4 are sufficiently small such that the amount of coupled power is small compared to the total, which could be 100s of Watts, which is applied to the antenna port 3 and so that the field in the slot 2 remains unperturbed by the measurement.

Each slot element in the applicator is fed from a phase and amplitude controllable radio frequency power source, figure 3. The fields in each applicator element slot due to its own excitation and fields coupled from other elements are sensed 4 and measured using measurement device 20 consisting of a phase / amplitude detectors, figure 4, and the values communicated to a control system 21. In this case an in-phase/quadrature demodulator 14 in conjunction with a pair of analog to digital converters 15 is used to measure the in-phase and quadrature voltage levels. The digital signal is then converted into a magnitude and phase using the microprocessor 16 and communicated to the measurement controller 21 via a measurement bus 17.

The control system 22 sets the amplitudes and phases 8 of the multi channel radio frequency power source 18 and measures 20 the resultant fields 4 applied from each element 26 and affords feedback control to ensure the applied fields are the required fields.

A typical usage paradigm is that a validated numerical electromagnetic model of the applicator array 19 is used with a patient specific EM model derived from CT, MRI or other image data within a treatment planning software. In the treatment planning software the target region or regions for treatment is defined and the optimum ideal excitation values (or non-ideal taking into account mutual coupling and mismatch based on the mutual coupling matrix for the model which may or may not closely correspond to the real coupling matrix due to the possible errors previously mentioned from which the ideal excitation can be calculated) are derived and the corresponding EM-field, SAR or temperature rise values across the whole of the target region or regions generated.

The target excitations are then transferred to the treatment control software and the patient placed in the applicator 19 at the position modeled in the treatment planning. The water bolus 25 is filled with deionized water.

The measurement devices 20 are put into calibration mode where the RF switch 13 in figure 4 is switched so that the calibration input phase reference signal from the bus 12 is measured by each measurement device to allow calibration of the phase of the device and also to remove the phase ambiguity of the ± 2 quadrature phase splitter in the in-phase/quadrature demodulator 14.

Each radio frequency power source output 11 channel of the multi channel radio frequency power source 18 is excited in turn to determine which applicator element 26 is connected to each output

channel and to measure the fields/currents 4 induced in all the elements to generate the actual mutual coupling matrix for the array 19 at the time of treatment. In addition the phase and amplitude offset due to the connecting cables or transmit channel differences can be eliminated or calibrated out. Phase shifts due to variation in applicator element impedance from the ideal, for example due to patient proximity and hence change in the dielectric constant immediate environment, are also eliminated.

Treatment is commenced with radio frequency power 18 being applied to each element 26 based on the treatment planning, either based on ideal or corrected (using the coupling matrix) excitations, the actual excitation levels are determined using the field monitoring 4 and measurement 20 and controlled by the feedback controller 27 to correct for any deviation from the desired excitation levels. Throughout the treatment the total output power from each channel 11 can be controlled 8 and the correct relationship between amplitudes and phase monitored 20 and controlled to the correct value. While the invention herein disclosed has been described by means of specific embodiments and applications thereof, numerous modifications and variations could be made thereto by those skilled in the art without departing from the scope of the invention set forth in the claims.

References Cited

US Patents

United States Patent 5251645

"Adaptive nulling hyperthermia array " Inventors: Fenn, Alan J. (Wayland, MA)

Assignee: Massachusetts Institute of Technology (Cambridge, MA).

United States Patent 4672980

"System and method for creating hyperthermia in tissue " Inventors: Turner, Paul F.

Assignee: BSD Medical Corporation (Salt Lake City, UT)

United States Patent US5441532 and WIPO Patent Application WO/1993/000132

"ADAPTIVE FOCUSING AND NULLING HYPERTHERMIA ANNULAR AND MONOPOLE PHASED ARRAY APPLICATORS", Inventors: Fenn, Alan J. (Wayland, MA)

Assignee: Massachusetts Institute of Technology (Cambridge, MA).

Other Literature

Calibration techniques for digital phased arrays, Fulton, C.; Chappell, W.; *Microwaves, Communications, Antennas and Electronics Systems*, 2009. COMCAS 2009. IEEE International Conference on Communications, Antennas and Electronic Systems. Publication Year: 2009 , Page(s): 1 – 10

A Built-In Performance-Monitoring/Fault Isolation and Correction (PM/FIC) System for Active Phased-Array Antennas, Kuan-Min Lee, Ruey-Shi Chu, and Sien-Chang Liu, *IEEE TRANSACTIONS ON ANTENNAS AND PROPAGATION*, VOL. 41, NO. 11, NOVEMBER 1993

K. M. Lee, R. S. Chu, and S. C. Liu, "A performance monitoring/fault isolation and correction system of a phased array antenna using transmission-line signal injection with phase toggling method," *IEEE AP-S 1992 Symposium Digest (Chicago, IL)*, July 18-25, 1992, vol. 1, pp. 429-432.

Claims

1. A system for producing a predetermined electromagnetic field distribution in a defined volume or region, comprising a multi-channel radio frequency or microwave power source (18) connected to an array (19) of electromagnetic field generating elements (26), and a feedback controller (27) for controlling the radio frequency or microwave power source (18) to achieve the desired electromagnetic field produced by each element (26) such that the superposition of the fields produced by each electromagnetic field generating element produces said predetermined electromagnetic field distribution in said defined volume, the feedback to the controller (27) being the amplitude and phase of the electromagnetic field generated by each of the generating elements, characterised in that current or field (electric, magnetic or electromagnetic) sensors (4) are integrated into each electromagnetic field generating element (26) for sensing directly the element excitation and hence indirectly the amplitude and phase of the electromagnetic field generated by each of the generating elements (26), said sensors (4) being interconnected with a measurement device (20) for determining the amplitude and phase of the signals from each sensor (4) and hence the electromagnetic field produced by each element (26).
2. A system according to claim 1 in which the electromagnetic field generating elements (26) are antennas (based on conductor or slot(2) elements) or coils.
3. A system according to claim 1 or claim 2, in which the multi-channel radio frequency power source (18) is provided with control means for individually controlling amplitudes and phases (8) to produce individually controlled radio frequency outputs (11).
4. A system according to any one of claims 1 to 3, in which the electromagnetic field generating elements (26) are provided with a feed port (3) to which radio frequency power from outputs (11) is applied, and one or more integrated sensors (4) for measuring the phase and amplitude of current flowing in a metallic element or field in a slot-based element (2) (which is the analogue of the current in a metal element), the output of the sensors being an electrical signal which is a measure of said current or field.
5. A system according to any one of claims 1 to 4, in which the electromagnetic field generating elements (26) are situated into an array (19) of arbitrary configuration such that each element(26) may be excited by the radio frequency power output (11) of one channel of the radio frequency power source (18) and such that the electrical signal from the integrated sensors (4) of the field generating elements (26) is proportional to the radio frequency current (or field in the case of slot) in each element (2).

6. A system according to any one of claims 1 to 5, in which the electromagnetic field generating elements (26) having integrated current (or field in the case of slot based elements) sensors (4) provide a direct indication of the relative amplitude and phase of the electromagnetic field produced by each electromagnetic field generating element in the presence of mutual coupling between elements and hence afford control of the applied fields in the presence of mutual coupling.
7. A system according to any one of claims 1 to 6, in which the measurement device (20) is of sufficient dynamic range to enable measurement of both phase and amplitude of the electrical signals from the sensors (4).
8. A system according to any one of the preceding claims in which the measurement device (20) is an In-phase/Quadrature (IQ) demodulator (14) or vector voltmeter, whereby multiplication of the measured electrical signals by a calibration factor can enable the electromagnetic field produced by each individual electromagnetic field generating element (26) to be quantified.
9. A system according to any one of claims 1 to 8, in which each electromagnetic field generating element (26) is integrated with a channel of the measurement device (20) to form a module such that each module may be provided with an individual identity or serial number such that calibration data can be seamlessly assigned to each electromagnetic field generating element, modules may be exchanged to enable rapid repair and / or servicing, and whereby the individual identity provides 'plug and play' capability with automatic detection of different hardware and assignment of calibration data.
10. A system according to any one of claims 1 to 9, in which the feedback controller (27) enables adjustment of the amplitude and phase (8) of each individual channel of the multi channel radio frequency power source (18) such that the electromagnetic field radiating element (26) currents (or fields in the case of slot based elements) sensed by the sensors (4) and measured by the measurement device (20) are the desired currents or fields.
11. A system according to any one of claims 1 to 10, adapted to focus radio frequency energy into one or more dielectric objects or one or multiple regions of said one or more dielectric objects, in order to excite atoms, molecules or cellular structures or to elevate the temperature within said one or more objects or one or multiple regions within the dielectric object or objects.
12. A system according to any one of claims 1 to 11, adapted to induce fields and currents into a human patient or specific regions within the patient to excite atoms, molecules, nerves or other chemical or cellular mechanisms.

13. A system according to any one of claims 1 to 10, adapted to locate objects in space.
14. A system according to any one of claims 1 to 13, in which control of the multi-channel radio frequency power source (18) connected to the array of electromagnetic field generating elements (19) in which the sensed currents (or fields in the case of slot based elements) are the desired current or field levels of the ideal array(19) without coupling or mismatch, implicitly correcting for the mutual coupling between and mismatch of the electromagnetic field generating elements without explicit knowledge of, and calculation based on, the mutual coupling and mismatch.
15. A system according to any one of claims 1 to 14, in which changes in the mutual coupling and mismatch due to presence of dielectric or metallic objects (e.g., patient, water bolus (25), support structures) or changes in the position of these objects are inherently taken into account.
16. A system according to any one of claims 1 to 15, in which the mutual coupling and mismatch, described in terms of a coupling matrix, of an arbitrary array (19) of electromagnetic field generating elements (26) can be determined directly by excitation (11) of each electromagnetic field generating element (26) in turn by a single channel of the multi channel radio frequency power source (18) and using the currents or fields measured by all the channels the measurement system(20) from all the integrated sensors(4) the coupling matrix for the array can be determined more accurately than by the use of standard network analysis methods as the non-ideal output impedances of each amplifier and connecting cable lengths are inherently accounted for.
17. A system according to any one of claims 1 to 16 in which the coupling matrix is used to calculate the initial amplitudes and phases of the radio frequency outputs (11) of the multi channel radio frequency power source (18) and the currents or fields measured by the measurement system (20) from the current or field sensors (4) integral to the electromagnetic field generating elements (26) and the feedback controller (27) used to fine tune the system to provide the desired currents or fields in the electromagnetic field generating elements.
18. A system according to any one of claims 1 to 17 in which each radio frequency output(11) from the multi channel radio frequency power source (18) that connects to individual electromagnetic field generating elements (26) can be connected in any order to the array (19) of electromagnetic field generating elements and the integrated current or field sensor (4) used to determine which radio frequency output is connected to which electromagnetic

field generating element and define the correct mapping between output and element eliminating incorrect electromagnetic field generation due to incorrect interconnection.

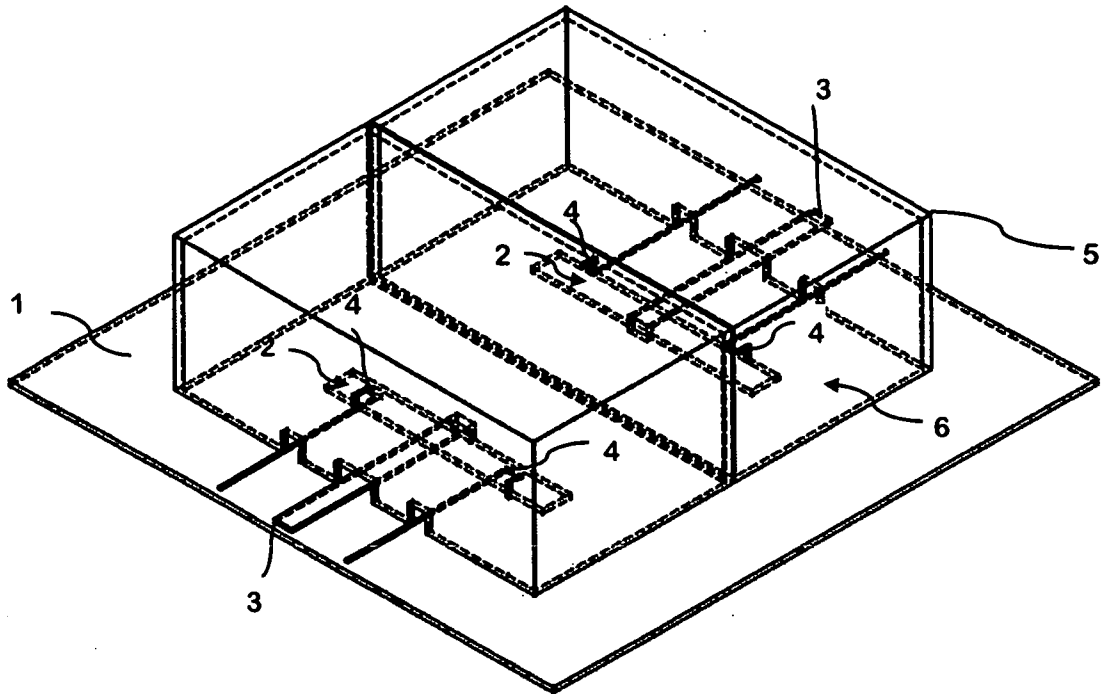

Fig. 1.

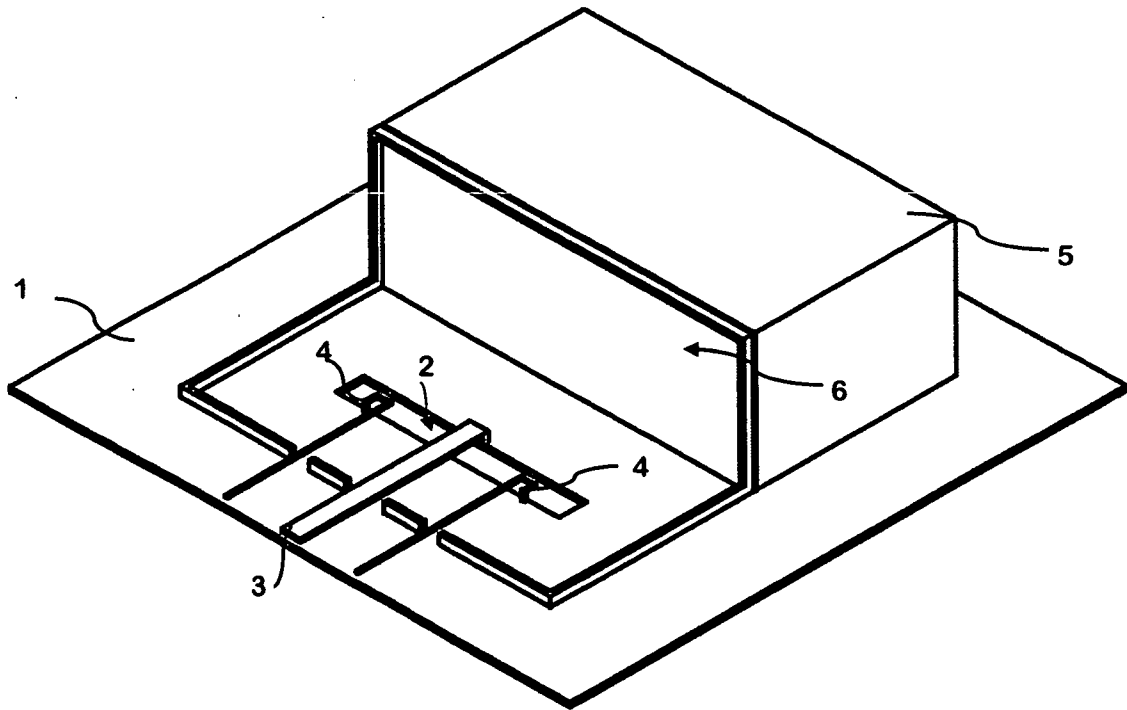

Fig. 1a.

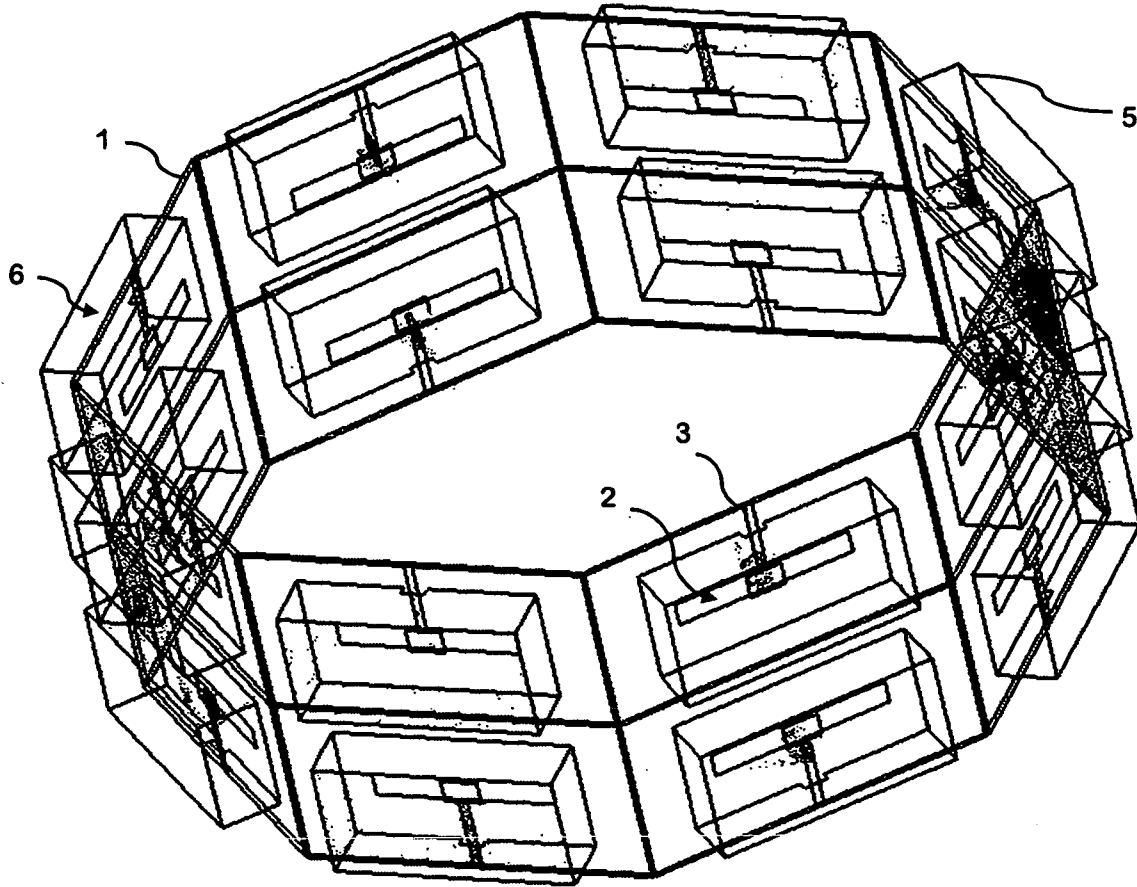

Fig. 2.

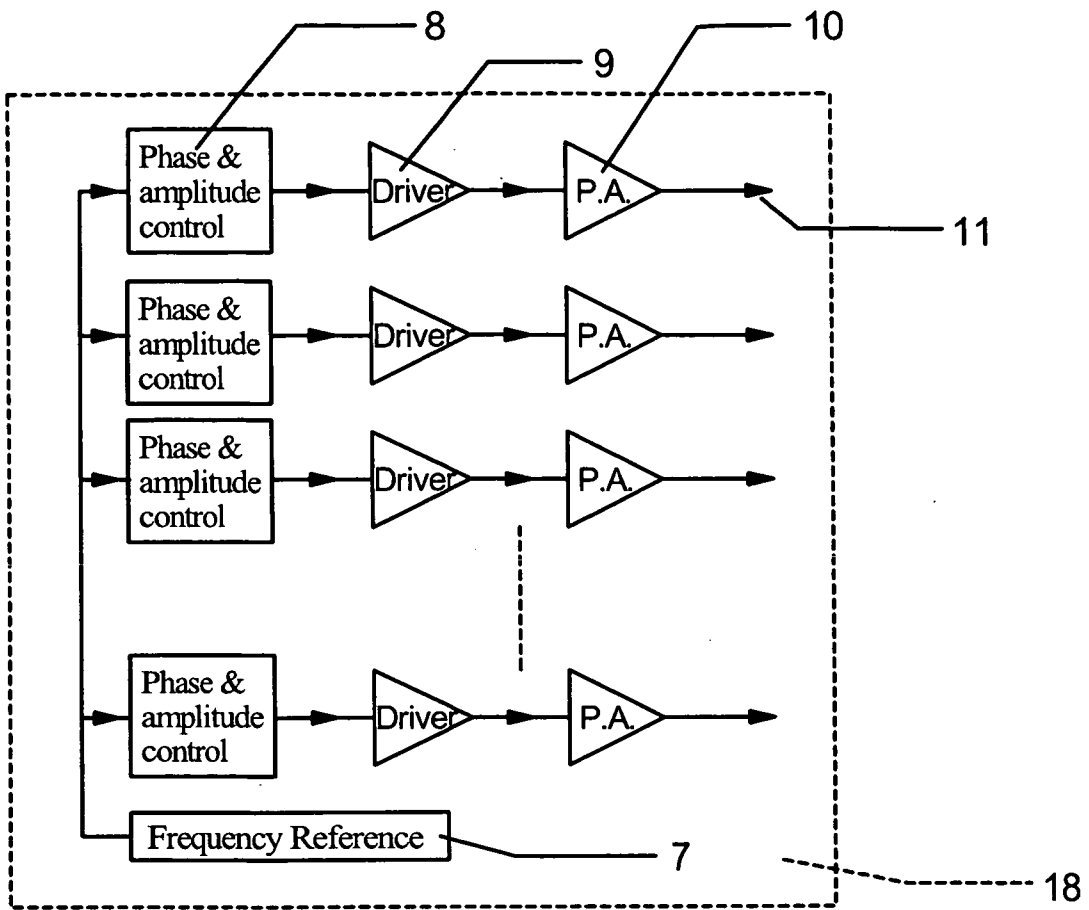

Fig. 3.

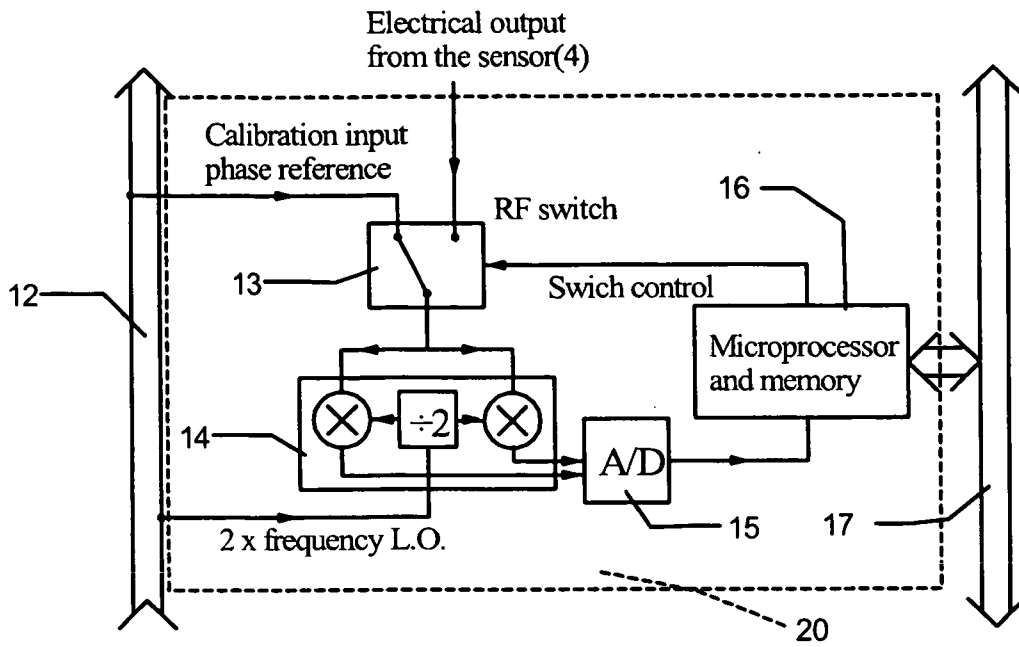

Fig. 4.

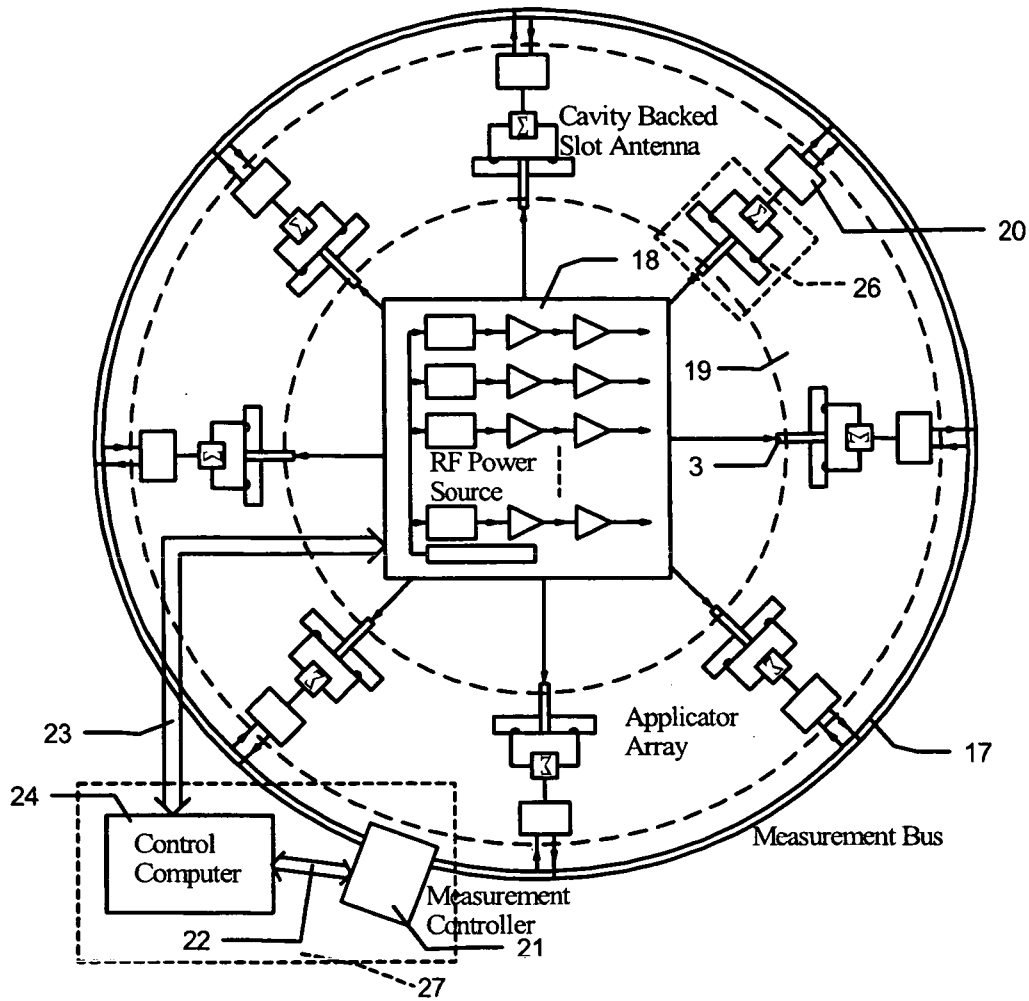

Fig. 5

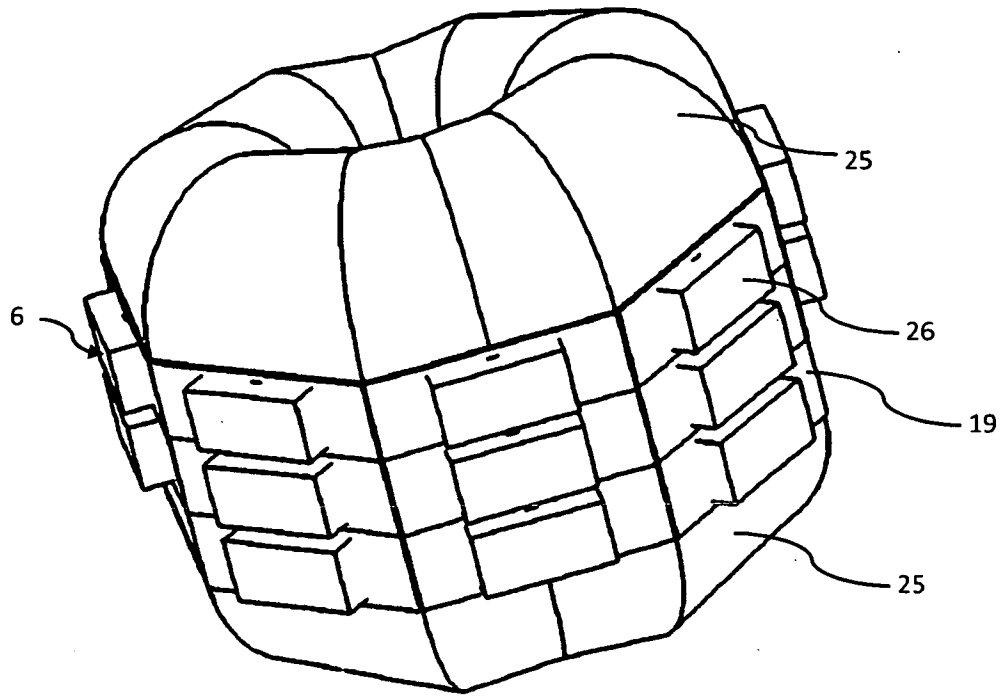

Fig. 6

INTERNATIONAL SEARCH REPORT

International application No
PCT/EP2011/065402

A. CLASSIFICATION OF SUBJECT MATTER
 INV. A61B18/18 A61N1/40 A61N5/02
 ADD.

According to International Patent Classification (IPC) or to both national classification and IPC

B. FIELDS SEARCHED
 Minimum documentation searched (classification system followed by classification symbols)
 A61B A61N

Documentation searched other than minimum documentation to the extent that such documents are included in the fields searched

Electronic data base consulted during the international search (name of data base and, where practical, search terms used)
 EPO-Internal, WPI Data

C. DOCUMENTS CONSIDERED TO BE RELEVANT

Category*	Citation of document, with indication, where appropriate, of the relevant passages	Relevant to claim No.
X	US 6 208 903 B1 (RICHARDS WILLIAM F [US] ET AL) 27 March 2001 (2001-03-27) column 1, line 62 - column 2, line 46 column 7, lines 5-30; claims 1-6; figures 5,7,7A	1-17
X	----- WO 2008/068485 A2 (MEDICAL DEVICE INNOVATIONS LTD [GB]; HANCOCK CHRISTOPHER PAUL [GB]) 12 June 2008 (2008-06-12) page 12, lines 13-30 page 28, lines 14-27; claims 1-6; figure 1(c) -----	1-15

Further documents are listed in the continuation of Box C. See patent family annex.

* Special categories of cited documents :

<p>"A" document defining the general state of the art which is not considered to be of particular relevance</p> <p>"E" earlier document but published on or after the international filing date</p> <p>"L" document which may throw doubts on priority claim(s) or which is cited to establish the publication date of another citation or other special reason (as specified)</p> <p>"O" document referring to an oral disclosure, use, exhibition or other means</p> <p>"P" document published prior to the international filing date but later than the priority date claimed</p>	<p>"T" later document published after the international filing date or priority date and not in conflict with the application but cited to understand the principle or theory underlying the invention</p> <p>"X" document of particular relevance; the claimed invention cannot be considered novel or cannot be considered to involve an inventive step when the document is taken alone</p> <p>"Y" document of particular relevance; the claimed invention cannot be considered to involve an inventive step when the document is combined with one or more other such documents, such combination being obvious to a person skilled in the art.</p> <p>"&" document member of the same patent family</p>
--	--

Date of the actual completion of the international search 18 January 2012	Date of mailing of the international search report 25/01/2012
--	--

Name and mailing address of the ISA/ European Patent Office, P.B. 5818 Patentlaan 2 NL - 2280 HV Rijswijk Tel. (+31-70) 340-2040, Fax: (+31-70) 340-3016	Authorized officer Link, Tatiana
--	---

INTERNATIONAL SEARCH REPORT

Information on patent family members

International application No

PCT/EP2011/065402

Patent document cited in search report	Publication date	Patent family member(s)	Publication date
US 6208903	B1	27-03-2001	
		AU 724810 B2	28-09-2000
		AU 6379496 A	30-12-1996
		BR 9609398 A	14-12-1999
		CA 2223136 A1	19-12-1996
		EP 0956097 A1	17-11-1999
		JP H11511043 A	28-09-1999
		US 5769879 A	23-06-1998
		US 6208903 B1	27-03-2001
		WO 9640369 A1	19-12-1996

WO 2008068485	A2	12-06-2008	
		AU 2007330615 A1	12-06-2008
		CA 2708250 A1	12-06-2008
		CN 101778650 A	14-07-2010
		EP 2121130 A2	25-11-2009
		JP 2010511459 A	15-04-2010
		US 2010036369 A1	11-02-2010
		WO 2008068485 A2	12-06-2008
