

N. P. OTIS.
GUIDE SHEAVE FOR ELEVATORS.

No. 522,429.

Patented July 3, 1894.

Fig. 1.

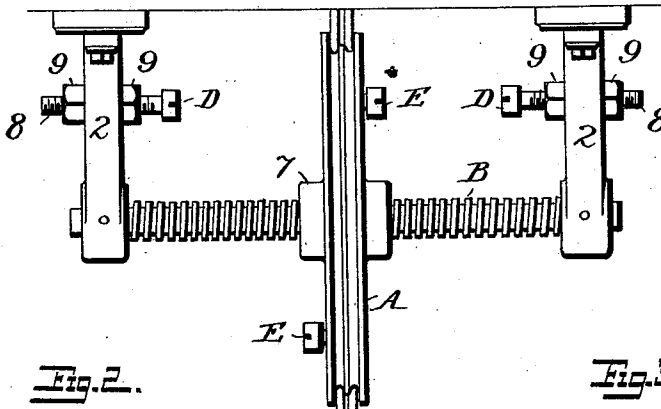

Fig. 2.

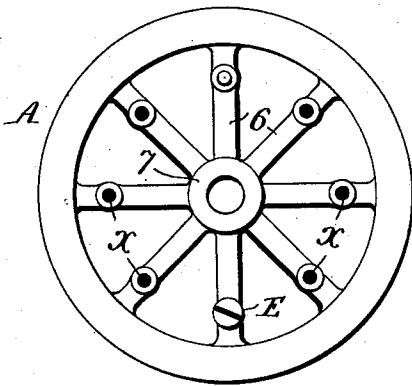
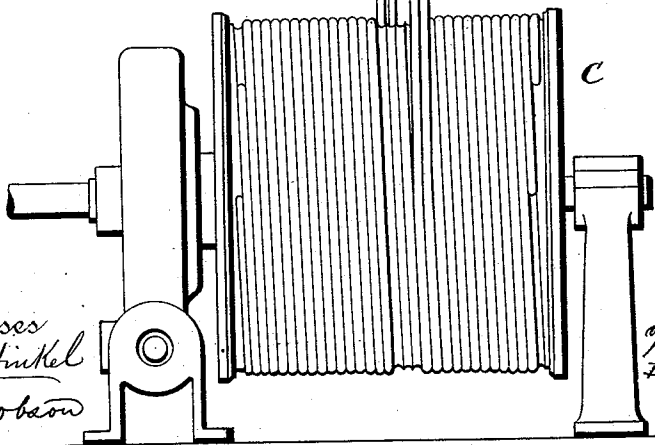
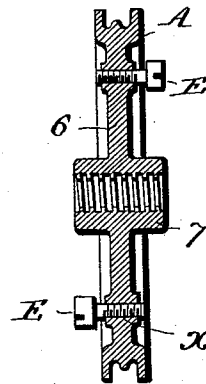

Fig. 3.



Witnesses
Jno G. Hinkel
A. S. Dobson

Inventor
Nathan Otis
By *John Freeman*
Attorneys

N. P. OTIS.
GUIDE SHEAVE FOR ELEVATORS.

No. 522,429.

Patented July 3, 1894.

Fig. 5.

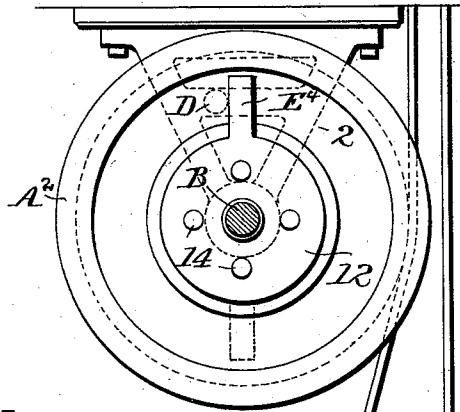

Fig. 4.

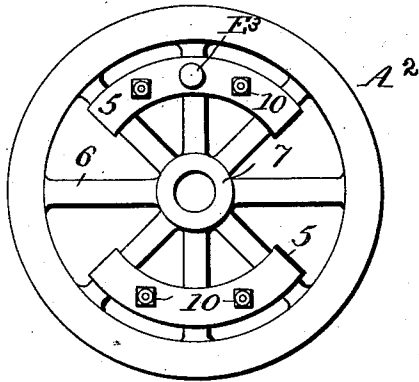
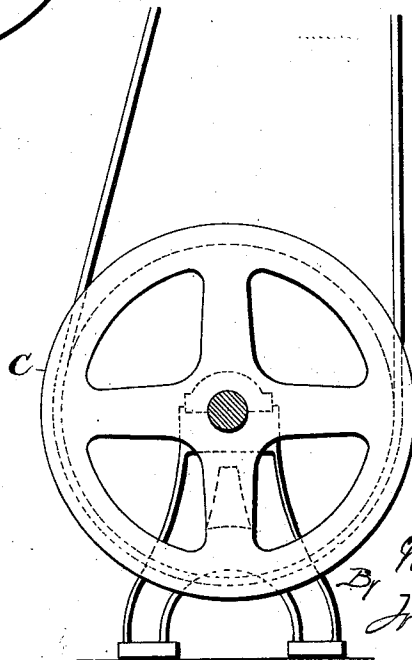
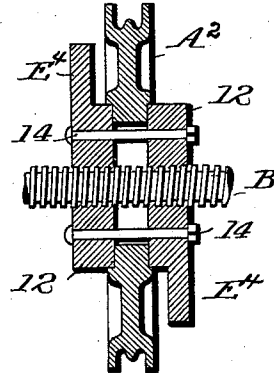

Fig. 5.



Witnesses
Jno. G. Hinkel
A. H. Robinson

Inventor
Norton P. Otis
 By *J. H. ...*
... & Freeman
 Attorneys

UNITED STATES PATENT OFFICE.

NORTON P. OTIS, OF YONKERS, NEW YORK.

GUIDE-SHEAVE FOR ELEVATORS.

SPECIFICATION forming part of Letters Patent No. 522,429, dated July 3, 1894.

Application filed November 23, 1893. Serial No. 491,737. (No model.)

To all whom it may concern:

Be it known that I, NORTON P. OTIS, a citizen of the United States, residing at Yonkers, in the county of Westchester and State of New York, have invented certain new and useful Improvements in Guide-Sheaves for Elevators, of which the following is a specification.

My invention relates to the sheaves that are used for guiding the deflected cables of elevator apparatus, and my invention consists of certain means fully set forth and claimed hereinafter, whereby to bring the sheave in proper relation to the cables and the winding drum at the end of each movement of the sheave.

In the accompanying drawings, Figure 1 is a front elevation of sufficient of the winding devices of an elevator to illustrate my invention. Fig. 2 is a side view of the guide sheave. Fig. 3 is a transverse sectional view of the guide sheave. Fig. 4 is a side view of the guide sheave showing another means of adjusting the stops thereon. Fig. 5 is a vertical sectional illustration of the parts illustrated in Fig. 1, but showing a two-part sheave. Fig. 6 is a transverse sectional view of the sheave shown in Fig. 5.

The winding drum C is connected with an operating engine of any suitable construction, either a steam engine, belt engine, electrical engine, or otherwise, and has spiral grooves for the reception of one, two or more parallel cables, which pass from the drum to the top of the well, and are connected to the cage or platform.

Where the cable or cables *d* (two cables being shown) have to be deflected, they pass around a guide sheave A, the hub 7 of which constitutes practically a nut that turns upon a threaded shaft B supported stationary in hangers 2, 2, suspended from a roof or ceiling, or connected to a wall, or otherwise supported.

As the cables move in contact with the sheave they rotate the latter and the sheave travels on the threads of the screw shaft, thereby avoiding the wearing of the cables that results when the latter are depended upon to drag the sheave laterally on a plain shaft. The pitch of the thread of the shaft B is such that the sheave A will move as fast as the lateral displacement of the cables, so

that the sheave will be practically in the vertical plane of the cables at all times, so that there can be no possible tendency of the winding sheave to lag behind and allow the portion of cable between the sheave and the winding drum to assume an angle that would throw the cables off the sheave. In order to preserve this alignment, however, and compensate for any inequalities in action, I provide means whereby there is an adjustment of the sheave in respect to the winding drum and cables at the end of each stroke. Such means consist of contact pieces E, E, upon the sheave, and contact pieces D, D, supported by the hangers or brackets 2, or any other stationary part of the apparatus, and so arranged that one of the contacts upon the sheave will meet one of the contacts upon the frame when the sheave reaches the proper limit of its movement in either direction, and I provide means whereby to permit a limited movement of the cable if necessary after the sheave has been brought to rest by the meeting of the contacts. Thus assuming that the sheave A has moved to the right until the contact E on the sheave at the right has met the contact D upon the frame at the right, the sheave will then be arrested in movement, and if the drum continues its movement thereafter, the cables will slip over the sheave until the movement of the drum is arrested. When therefore the movement of the drum is reversed, the sheave will start back in its proper position in respect to the drum and the cables, toward the left hand end of the hanger, where a like operation will ensue, the sheave thereafter starting on its return movement toward the right in proper relative position to the cables and the drum.

As in many instances the height of the well is such that the cable need not be completely unwound from the drum in order to secure the proper travel of the cage, the contacts may be adjustable so as to meet when the sheave A is at any desired point upon the screw B. For instance, each stop D may consist of a threaded rod 8 passing through the hanger 2, and provided with clamping nuts 9, 9, by which the stop may be set to and secured in any desired position. As it is necessary also to set the stops E in different positions, each of the arms 6 of the sheave A may

have a threaded opening α to receive the threaded stem of the stop E, consisting practically of a screw bolt, or the stop may be a projection E³ upon one of two clamping plates 5
5 arranged on opposite sides of the spokes 6 and clamped together to the said spokes in any suitable position by means of bolts and nuts 10, 10.

Where it is desired to avoid the running of 10 the cables over the sheave A after the latter has come to rest, and the friction and wear that would result therefrom, means may be employed for permitting the movement of the rim of the sheave with the cables without 15 moving the hub 7 constituting the nut. Thus as shown in Figs. 5 and 6, the rim A² of the wheel has a central opening and is clamped between two disks 12, 12, which constitute the hub or nut of the wheel, the clamping being effected by means of screw bolts 14 which 20 may be adjusted to secure any desired frictional adhesion of the hub and the rim of the wheel. Arms E⁴ projecting from the disks 12, 12, constitute the stops, and when either 25 arm strikes a stop D, the travel of the sheave upon the screw shaft B is prevented but the rim of the sheave may move to a certain extent with the cables d so that there is no frictional travel of the cables upon the rim.

30 Without limiting myself to the precise construction and arrangement of parts shown, I claim as my invention—

1. The combination with a winding drum, of a stationary screw shaft and a guide sheave 35 traveling on said shaft and arranged to receive the cables passing from the drum, and

adjustable contacts for arresting the traveling movements of the sheave, substantially as described.

2. The combination with the drum and cable of an elevator apparatus, of a stationary screw shaft, a pulley having a threaded hub traveling thereon, contacts on the pulley and on the stationary frame, and means for permitting a limited movement of the cable after 45 one of the contacts has been brought to bear against the other, substantially as set forth.

3. The combination with the drum, cable and guide sheave of an elevator, of contacts upon the frame of the apparatus, and contacts 50 upon the sheave arranged to strike and arrest the movement of the sheave when it reaches the limit of its travel in either direction.

4. The combination with the drum and cable of an elevator apparatus, of a stationary 55 screw shaft, a sheave thereon, stops upon the sheave, and stops longitudinally adjustable upon the frame of the apparatus, substantially as set forth.

5. The combination with the drum, cable, 60 sheave, and stationary screw shaft, of stops upon the frame of the apparatus, and stops carried upon the sheave and adjustable to different positions upon the sheave, substantially as and for the purpose set forth. 65

In testimony whereof I have signed my name to this specification in the presence of two subscribing witnesses.

NORTON P. OTIS.

Witnesses:

HENRY L. BRANT,
W. L. RICKARD.