

(19)



(11)

EP 3 138 975 B1

(12)

EUROPEAN PATENT SPECIFICATION

(45) Date of publication and mention of the grant of the patent:
12.06.2019 Bulletin 2019/24

(51) Int Cl.:
E04B 2174 (2006.01) E04F 13/24 (2006.01)
E04G 21/24 (2006.01) E04B 2/82 (2006.01)

(21) Application number: **15785791.3**

(86) International application number:
PCT/ES2015/000057

(22) Date of filing: **29.04.2015**

(87) International publication number:
WO 2015/166119 (05.11.2015 Gazette 2015/44)

(54) **KIT FOR ERECTING WALLS**

KIT ZUM STELLEN VON WÄNDEN

KIT POUR ÉRIGER DES PAROIS

(84) Designated Contracting States:
AL AT BE BG CH CY CZ DE DK EE ES FI FR GB GR HR HU IE IS IT LI LT LU LV MC MK MT NL NO PL PT RO RS SE SI SK SM TR

(74) Representative: **Juncosa Miró, Jaime Torner, Juncosa i Associats, S.L.**
Gran Via de les Corts Catalanes, 669 bis, 1^o, 2^a
08013 Barcelona (ES)

(30) Priority: **30.04.2014 ES 201430588**
17.02.2015 ES 201530186

(56) References cited:
CA-A1- 2 739 414 DE-U1- 29 500 415
FR-A- 429 863 FR-A1- 2 712 064
NL-C2- 1 017 028 US-A- 2 770 886
US-A- 2 855 037 US-A- 2 855 037
US-A- 3 349 528 US-A- 3 349 528
US-A- 3 686 810 US-A- 5 088 672
US-A- 5 826 847

(43) Date of publication of application:
08.03.2017 Bulletin 2017/10

(73) Proprietor: **Ibañez Castillo, Enrique**
43700 El Vendrell (Tarragona) (ES)

(72) Inventor: **IBAÑEZ CASTILLO, Enrique**
43700 El Vendrell (Tarragona) (ES)

EP 3 138 975 B1

Note: Within nine months of the publication of the mention of the grant of the European patent in the European Patent Bulletin, any person may give notice to the European Patent Office of opposition to that patent, in accordance with the Implementing Regulations. Notice of opposition shall not be deemed to have been filed until the opposition fee has been paid. (Art. 99(1) European Patent Convention).

Description

Field of the Art

[0001] The present invention relates to a kit for erecting walls including a plurality of props, cladding panels and securing devices. Said prop applies axial pressure against two parallel planes by means of the elastic element, providing active propping, and the extendable nature of the prop allows said prop to be easily installed and removed without labor, as well as allowing the pressure exerted by the elastic element to be regulated. The prop can be used as a structure for dry-mounted cladding by means of removably securing cladding panels to tubular elements, especially to securing devices in the form of a spring clip suitable for being anchored to a tubular element and provided with coupling means suitable for the anchoring of one or more cladding panels.

State of the Art

[0002] The use of extendable props provided with an elastic element for being fitted between two parallel planes is known.

[0003] Patent document DE202004016792U, for example, describes props of this type which integrate at their upper end an elastic element as well as a threaded element for expanding the prop, increasing the force exerted by the prop on the floor and ceiling, and are used as support for holding partitions for dividing spaces, especially offices. The upper and lower ends of this solution have a bell shape to increase the contact surface area, which prevents the cladding from covering said upper and lower ends. This prior art does not propose a divisible prop, so it will be hard and costly to handle and transport.

[0004] Patent document GB695937 also describes an element with similar features, and in this case the prop is divided into two telescopically attached segments of different diameter, and it includes an elastic element and a threaded element for regulating the total length of the prop, and for including elastic strain for fitting the prop, but, besides having two segments of different diameter, a pin must be introduced to work as a stop, and the threaded element acts on said pin to separate the two segments.

[0005] Patent document US4449876 describes a threaded element integrated with an element elastically movable with a spring, and both are integrated with a connecting element which allows coupling this device to the end of a wooden prop, so that it can be fitted inside a vehicle for securing a load. This embodiment does not include any tubular element in which said threaded or movable elements are inserted. Furthermore, the coupling thread attaching the threaded element to the rest is part of the movable element, and can therefore move as it is free. To prevent the coupling thread from also rotating when the threaded element rotates, the coupling thread has a rectangular shape and is inserted in a rec-

tangular compartment.

[0006] Cladding can be secured on the extendable prop by means of securing devices of the type having two elastically deformable arms arranged opposite one another which can be anchored to and released from the prop, and are attached to a coupling means complementary with the cladding panels.

[0007] Patent document DE202006005611 describes an embodiment of said securing device, but it is not envisaged for coating two opposite faces of one and the same group of props, or for allowing the cladding panels of both faces to be arranged opposite one another.

[0008] Patent document FR2936827 also describes a similar product with the same drawbacks.

[0009] Securing cladding panels to tubular elements is known, for example, by means of patent document DE202004016792U, which describes a system consisting of extendable props to which dividing panels are secured.

[0010] Another document describing an extendable prop to which dividing panels can be secured by means of securing devices is patent document ES1117832U, filed by the same applicant as the present invention.

[0011] Documents describing securing devices that can be coupled to a tubular element and provided with a coupling means which allows securing panels are also known. Document EP1850045A describes support clips for pipes having elastically deformable arms arranged opposite one another and attached to a support which integrates a coupling means.

[0012] Documents DE29500415U and CA2739414 describe extensible props. Document US2855037 describes a kit for erecting walls including props and cladding panels, but not using a clipping system to attach said cladding panels to the props.

Brief Description of the Invention

[0013] The present invention relates to a kit for erecting walls including a plurality of extendable props, cladding panels and securing devices according to claim 1.

[0014] Each prop having:

- a tubular element of the prop defining a longitudinal direction;
- at least one threaded element, which is partially housed inside the mentioned tubular element of the prop, and attached thereto by means of a coupling thread providing an adjustable insertion and/or extraction of said threaded element with respect to said tubular element of the prop, thereby increasing or reducing the total length of the extendable prop in the longitudinal direction; and
- at least one compressible elastic element susceptible of reducing the total length of the extendable prop, since said extendable prop is subjected to axial compression in the longitudinal direction.

[0015] The threaded element thereby allows increasing or reducing the total length of the extendable prop by rotating with respect to the coupling thread, adapting the total length of the extendable prop to the distance existing between two parallel planes between which said extendable prop is to be fitted.

[0016] The threaded element can be a cylindrical body with one or more threads on its outer face, and can be inserted into the tubular element, in which there is arranged the coupling thread which can consist of one or more female threads made directly on the inner face of said tubular element, or consist of a bushing having a coupling thread with an inner cylindrical cavity on which one or more threads have been made, said bushing having a coupling thread being fixed to the tubular element.

[0017] There can be one or more threads providing several notches in the threading. The thread pitch can also be of different amplitude to achieve faster or slower regulation of the threaded element. Having several threads allows providing a greater or the same thread pitch, providing a tooth with the same or smaller height than if there were only a single thread.

[0018] Said elastic element is attached to a movable element which is in turn attached, in a manner movable in the longitudinal axial direction, to the tubular element of the prop, such that when compressing the extendable prop in said direction, relative movement between the movable element and the tubular element of the prop occurs, offering elastic strength provided by the elastic element.

[0019] Said elastic element can be, in a non-limiting preferred manner, a spring with one of its ends secured with respect to the tubular element of the prop by means of a flange, a stop or a pin, for example. Other solutions consisting of equivalent elastic elements, such as the use of a pneumatic piston or an elastomer, for example, are also accepted. Said movable element can be an element with an outer section having a size smaller than the inner section of the hollow profile into which it is inserted, being house loosely therein and allowing relative longitudinal movement.

[0020] The tubular element of the prop is made up of a plurality of tubular segments with the same sized outer section arranged coaxial and coaligned with one another, all the tubular segments forming the tubular element of the prop being susceptible of being attached to one another by means of at least one connecting element.

[0021] Said plurality of tubular segments can be, in a non-limiting manner, a first tubular element and a second tubular element. Optionally, the plurality of tubular segments can include additional tubular elements that can be attached to the first and second tubular elements for obtaining a longer prop, or segments of shorter and therefore more manageable tubular element. Said additional tubular elements will have the same outer section as the first and second tubular elements, and will be connected to one another or to said first and second tubular elements by means of the threaded element, the movable

element, the connecting element, or by means of additional connecting elements.

[0022] The individual length of each individual tubular segment is less than three fourths the total length of the extendable prop when fully extended, and it is preferably half the length of the tubular element of the prop if there are no additional tubular elements, and one third or one fourth the length of the tubular element of the prop if there are one or two additional tubular elements, respectively, they can therefore be transported in an easy and cost-effective manner in a shorter packet, or can even be delivered by a courier service, reducing logistics costs, and making long-distance selling and purchasing easier.

[0023] Each of the tubular segments of the plurality of tubular segments will preferably have a length less than 110 cm.

[0024] One of or all the tubular segments can be made of a metallic material, preferably aluminum, and have a protective surface finish, such as anodizing, lacquering, varnishing, galvanizing, painting, or any other surface finish, and can have an outer finish that is smooth, fluted, jagged, with notches or with holes.

[0025] The connecting element which allows attaching two tubular segments to one another can be, by way of example, an element with an outer section having a size equal to or slightly smaller than the inner section of one of said tubular segments, thereby allowing an unskilled user to manually insert a portion of said connecting element in a tight-fitting manner into each of the tubular segments without using any tools, thereby providing a rigid attachment. Optionally, relative rotation between said connecting element and the tubular segment can be allowed, and said rotation can be made easier by means of using materials with a low coefficient of friction, such as Teflon, or lubricating products, for example.

[0026] Other configurations of the connecting elements are allowed, such as threaded attachments, conical attachments, or by means of screws or pins that will be complementary with coupling means envisaged at the end of the tubular segments. In the case of the threaded attachment, the coupling is performed by means of a coupling thread machined on the inner face of the tubular segment, or by means of a bushing having a coupling thread fixed on said tubular segment.

[0027] Said connecting element can have a maximum insertion limiter regulating the depth to which the connecting element is inserted into the tubular segments it connects. Said maximum insertion limiter can be, by way of example, a central portion of the connecting element with an outer section being of a larger size than the size of the inner section of said tubular segments, therefore working as a stop. This maximum insertion limiter will preferably have an outer section being of the same size as the outer section of the tubular segments.

[0028] The threaded element will be attached by means of the mentioned coupling thread to an end of a tubular segment.

[0029] The movable element will be attached to an end

of a tubular segment.

[0030] Optionally, the connecting element will also be attached to an end of a tubular segment.

[0031] The optional non-limiting possibility that the movable element is integrated with the threaded element, or that the movable element is integrated with the connecting element, or that the connecting element is integrated with the threaded element, or that the movable element and the connecting element are integrated with the threaded element, is also contemplated.

[0032] By way of non-limiting example, the threaded element can therefore work as a connecting element and can be located between two consecutive tubular segments, such as between the first and second tubular elements, for example, just as the movable element can occupy this position and also work as the connecting element.

[0033] The upper and lower ends of the extendable prop can have an element having a high coefficient of friction arranged on each of the contact surfaces of the extendable prop with said two parallel planes. These elements, together with the compressive force of the elastic element introduced by means of the extension of the extendable prop by means of the threaded element, securely fit the extendable prop, making it very difficult for an external force, exerted in a direction perpendicular to the longitudinal direction, to laterally move one of the two ends of the extendable prop.

[0034] Additionally, there can be added a stop part, for example in the form of a ring with an inner cavity in which the end of the prop would be inserted in a tight-fitting manner, and with an outer rectangular, square, circular geometry, etc., secured to one or both parallel planes by means of adhesives or mechanical securing, thereby making lateral movement even more difficult. It can also serve as a guide for an initial positioning of the extendable prop during mounting.

[0035] Said elements having a high coefficient of friction, for example, rubber or neoprene parts, can be secured directly to the farthest ends of the two most distant tubular segments, for example, at the free ends of the first and second tubular elements. It is also contemplated that said elements having a high coefficient of friction can be secured to the end of the movable element or of the threaded element.

[0036] Additionally, said element having a high coefficient of friction can be linked to the end of a tubular segment by means of a rotary attachment which allows relative rotation about an axis parallel to the longitudinal direction, offering little friction, for example, by means of a disc made of a material having a low coefficient of friction, for example, Teflon, or by means of a disc attached to a shaft and provided with a bearing.

[0037] Said rotary attachment can allow a tubular segment to rotate with respect to the other tubular segment, for example, when regulating the threaded element, without it causing the rotation or movement of the element having a high coefficient of friction with respect to the

plane on which it is supported.

[0038] According to an alternative embodiment, said rotary attachment includes a threaded regulator which allows, by means of the rotation thereof, said element having a high coefficient of friction to move closer to or away from the respective tubular segment. This threaded regulator can allow precisely increasing or reducing strain that the extendable prop exerts on the parallel planes to which it is fitted, regulated by means of the elastic element connected to the movable element.

[0039] Optionally, the movable element can be additionally provided with an indicator device which visually indicates the amount of elastic force exerted by said elastic element when subjected to compression. One embodiment of said indicator device can be, by way of example, a ruler which allows measuring relative movement between the movable element and the tubular segment housing it, which allows knowing the exerted elastic force by means of Hooke's Law.

[0040] These features allow using the mentioned extendable prop as active propping which exerts axial force on the parallel planes against which the prop is fitted, furthermore being able to regulate the intensity of said axial force by means of the indicator device. It also allows the prop to accept and absorb relative movements between the two parallel planes by means of applying a load on and removing a load from the elastic element, without the position and function thereof being compromised.

[0041] The fitting of the prop therefore requires first attaching the plurality of tubular segments, for example, the first and second tubular elements, by means of at least one connecting element. Next, the prop is arranged in the desired position and the length of the prop is increased by means of regulating the threaded element until the ends of the prop come into contact with the two parallel planes, then the active strain exerted by the elastic element must be increased by means of additional regulation of the threaded element, or optionally by means of relative rotation of the threaded regulators with respect to the extendable prop, until the strain indicated by the indicator device is the desired strain.

[0042] In an alternative application, said extendable prop can be used for temporarily and removably securing equipment indoors, such as for holding spotlights or loudspeakers for events, for example.

[0043] An unskilled user can secure a plurality of vertical props, optionally aligned and equidistant with respect to one another, easily and without requiring any tools. Said plurality of props can serve as a support structure for holding a cladding, a partition or a space dividing element, such as, for example, rigid wood panels, plastic panels, resin panels, glass panels, gypsum panels, ceramic panels, stone panels, panels made of agglomerated materials, furniture, etc., or for holding flexible elements such as curtains or blinds. Said elements may be secured to the extendable prop by means of removable and reusable securing devices, such as systems for at-

tachment by elastic deformation, for example.

[0044] In some of these applications, the feature that all the segments of the plurality of tubular segments have the same outer section is advantageous since this allows securing a standardized securing device to said prop at any point of the length thereof.

[0045] The inner section of the tubular segments can be different, the thickness of their outer walls varying, being better adapted to loads supported by each of the tubular elements, or to the required coupling means.

[0046] In some cases it is also advantageous for all the tubular segments to have a circular section since it allows said securing elements to be located, without distinction, in any angular position.

[0047] If a securing device is to be secured to the exposed sector of the threaded element, which by definition will have a section different from that of the tubular segments, a third tubular element provided with a coupling thread can be positioned on said exposed fraction of the threaded element, which can be located in any longitudinal position of said exposed threaded element, serving as a support for the securing device. Said third tubular element can also be used for locking the position of the threaded element with respect to the coupling thread with a tubular segment, acting like a locking counter-thread.

[0048] The possibility that the tubular segments have holes in their outer walls to allow the passage of conduits through the inside thereof for securing elements to their surface, or for inserting tools to make their regulation easier, and that the wall of the tubular segments can have a finish that is smooth, but also fluted, with notches, with several holes or jagged, to favor connecting with external attachment elements, is also envisaged.

[0049] Finally, it is also considered optimal that no element of the extendable prop projects from the plane defined by the outer face of the tubular segments since it prevents any element of the prop from being able to interfere with a securing device or with an element secured in any one position of the extendable prop, in addition to producing advantages in terms of aesthetics and safety as it does not have projecting elements that may harm a user.

[0050] The described prop includes a plurality of securing devices for removably securing cladding panels to said tubular elements, which allows erecting partitions, dividers or walls on a support structure formed by a plurality of tubular elements in a fast, safe and simple manner without using any tools.

[0051] Said tubular elements can be of different kinds, being able to be mounts attached on a support, or props fitted between a floor and a ceiling.

[0052] The proposed securing device for securing panels comprises:

- a clamp having a first arm and a second arm that are elastically deformable and arranged opposite one another, both arms being provided with a proximal end and a distal end, the proximal ends of the first

and second arms being attached to a support, and the distal ends of the first and second arms being arranged opposite and spaced from one another, said distance being smaller than a width measurement of a tubular element, and the clamp being able to be coupled to and uncoupled from said tubular element by means of elastic deformation of said first and second arms under pressure;

- at least one coupling means arranged in said support to which at least one cladding panel can be removably secured;

the tubular element being a linear element elongated in the direction of a longitudinal axis.

[0053] Said clamp can therefore be coupled on said tubular element by means of the elastic deformation of the first and second opposite arms of the clamp. Said coupling will be achieved by the clamp pressing against the tubular element, exerting a force transverse to the longitudinal axis of said tubular element.

[0054] After coupling, the first and second arms will be retained, surrounding the tubular element, and for uncoupling same, a force transverse to the longitudinal axis equivalent to the force used for coupling, but in the opposite direction, will be required.

[0055] Both arms of the clamp share a common support arranged in the base thereof, and on which there has been envisaged at least one coupling means which allows removably securing at least one cladding panel.

[0056] Said securing device has at least one joining means arranged in at least one of the first or second arms, said joining means being able to be coupled to another complementary joining means of another securing device provided with at least a support and joining means, the coupled assembly of both securing devices forming a tight-fitting casing around the tubular element.

[0057] It is optionally contemplated that the other securing device is identical to the initially described securing device.

[0058] Two complementary and optionally identical securing devices can therefore be mutually coupled by means of the coupling of the respective joining means. Said mutual coupling will result in a casing surrounding the tubular element, reinforcing and securing the relative position of both securing devices, which will be arranged with the corresponding supports on opposite sides of the tubular element, and both supports preferably being at the same height with respect to the longitudinal axis determined by the tubular element.

[0059] According to another embodiment, said other securing device also includes a first arm and a second arm, and with the initially described securing device being coupled to said other securing device which is optionally identical to the former device, the proximal part of the first and second arms of the securing device is juxtaposed with respect to the distal part of the first and second arms of the other securing device. According to this embodiment, the coupling is obtained by means of the juxtapo-

sition of both clamps arranged around a tubular element, installing them laterally adjacent and contiguous to one another, their respective arms also being juxtaposed.

[0060] The direction of coupling and uncoupling the joining means of the clamp with respect to the joining means of the other clamp is preferably approximately parallel to the longitudinal axis of the tubular element, the clamps being coupled to said tubular element. This means that the direction of mutual coupling of the joining means is approximately perpendicular to the direction of coupling and uncoupling of the clamps with respect to the tubular element, a first uncoupling of the joining means being required to enable releasing the clamps with respect to the tubular element. This allows obtaining a much more secure attachment of the clamps to the tubular element, and accordingly, of the cladding panels to the support.

[0061] The mentioned support has coupling means envisaged for removably securing in a simultaneous manner at least two laterally adjacent, contiguous and coplanar panels to a face of the support, said panels being parallel to the longitudinal axis of the tubular element.

[0062] According to one embodiment, said anchoring takes place in an attachment configuration close to an upper corner of each of the two panels. This means that for holding said panels, another attachment configuration close to the other upper corner of each of the panels will have to be coupled to a different additional securing device, anchored to a different and parallel tubular element, thereby providing at least two attachment configurations to each panel, making it stable.

[0063] Optionally, a coupling means of a securing device can anchor, in addition to two laterally adjacent panels at one of their upper corners, one or two additional panels located in a superimposed position coplanar with the two described panels by an attachment configuration for attaching each additional panel located close to one of the lower corners thereof. Four panels can thereby be coupled to a single securing device. Obviously, the superimposed additional panels will require supplementary attachment configurations anchored to different securing devices for them to be stable, each panel being able to be held by its four corners by means of four different securing devices.

[0064] It is also contemplated that the laterally adjacent and/or superimposed panels are mutually coupled by means of a tongue and groove configuration envisaged on their side faces arranged mutually opposite one another.

[0065] According to a preferred embodiment, said coupling means has at least one rectangular main flange projecting perpendicularly from the support, having two main faces perpendicular to the longitudinal axis of the tubular element, the securing device being anchored to said tubular element. Said two main faces will be longest faces of the main flange, and are envisaged for interacting with complementary parallel faces envisaged inside a main groove made on each panel forming the attach-

ment configuration for attaching said panel to the securing device.

[0066] Said main flange provides the vertical positioning of the panel as it is coupled inside said main groove, providing the coupling of the coupling means with the attachment configuration of the panel. The main faces of the main flange can be pressed against the inner walls of the main groove or can optionally have a certain clearance.

[0067] Each panel is preferably supported on the panel immediately therebelow, transmitting vertical forces from one panel to another until reaching the lower panel which can transmit the loads to the floor or to a lower base profile on which said lower panels are supported. The contact between the superimposed panels can be made by means of a tongue and groove configuration provided with flanges and grooves or complementary steps which prevent relative horizontal movement between the superimposed panels.

[0068] The inclusion of operable retainers secured on the rear face of the panels, and envisaged for pressing on the coupling means and retaining them in the attachment configurations of the panels is also proposed.

[0069] The mentioned flange will preferably have a thickness of 3 millimeters and will project about 4 millimeters from the support. It will be at least 40 millimeters long, ideally 58 millimeters. Said main faces will therefore be 58 millimeters long and 4 millimeters wide.

[0070] The main groove will accordingly have a minimum width of 3 mm and a depth of 4 mm, being able to have an optional clearance of one or two millimeters. Said main groove will ideally be connected with a side face of the panel, such that by placing two panels laterally adjacent, coplanar and aligned with one another, their respective main grooves will also be aligned. The combined length of said two main aligned grooves will be equal to or greater than the length of the complementary main flange.

[0071] It is also contemplated that said main faces have harpoon-type reliefs, fins or retainers retaining said main flanges inside the main grooves by means of an elastic expansion force.

[0072] Additionally, the coupling means can include other secondary flanges securing the horizontal position of the panels with respect to the securing device, allowing the anchoring thereof in a single position.

[0073] By way of example, two rectangular secondary flanges are each envisaged to have two faces parallel to the longitudinal axis of the tubular element, therefore being perpendicular to the main flange. Said two secondary flanges will each be located adjacent to one of the two ends of the main flange, preferably symmetrically with respect to a vertical plane, each of said two secondary flanges being coupled to a secondary vertical groove envisaged in a position adjacent to the upper corners of each panel.

[0074] By way of non-limiting example, said secondary flanges can each have a thickness of 3 mm and project

perpendicularly about 4 mm from the support, their length being, for example, 18 mm. The distance between both secondary flanges can be 82 mm.

[0075] According to another embodiment, each coupling means includes, in addition to the horizontal main flange and the two symmetrical vertical secondary flanges, another additional flange which will ideally be symmetrical to the main flange with respect to a horizontal plane, envisaged for being coupled to additional grooves envisaged in a position adjacent to the lower corners of other two superimposed panels.

[0076] The distance between the main flange and the additional flange can be, by way of example, 64 mm.

[0077] It is obvious that different geometries and distances of the coupling means are applicable and that another type of coupling means will also be acceptable, such as hook configurations, lug configurations, or even magnets or screws, for example.

[0078] According to a specific embodiment in which the two securing devices mutually joined to one another through the joining means around the tubular element are identical, the mentioned horizontal plane of symmetry of the coupling means of the support of one of the securing devices is coplanar with another plane of symmetry of the coupling means of the support of the other securing device. This allows the coupling means of the clamp and of the other clamp to be arranged opposite one another on opposite sides of the tubular element, and therefore the panels to be secured thereto, located on opposite faces of the tubular element, to also be aligned and arranged opposite one another.

[0079] According to this or another similar embodiment, with the clamp being coupled to the other clamp, the first arm of the clamp is juxtaposed and laterally adjacent to the first arm of the other clamp, and the second arm of the clamp is juxtaposed and laterally adjacent to the second arm of the other clamp. This arrangement means that the support of the two juxtaposed clamps are located on opposite sides of the tubular element, and that the corresponding arms are located laterally adjacent and in contact with one another, the other clamp being arranged in an inverted position with respect to the initial clamp.

[0080] The arms are preferably attached to the support, the joining means being located in a plane of symmetry of the support, said plane being perpendicular with respect to the longitudinal axis of the structural element, so when coupling two clamps by means of said joining means, the supports of both clamps will be located on opposite sides of the tubular element and at the same height with respect to the longitudinal axis determined by the tubular element.

[0081] In reference to the joining means which allow the mutual coupling of the clamp with another clamp, each first and second arm consists of two joining means.

[0082] If the clamp is attached to another securing device that has no arms, said joining means must be located at the distal ends of said arms of the clamp in order to

reach the other joining device and allow the coupling thereof to other joining means of the other securing device, allowing a tight-fitting anchoring around the tubular element.

[0083] In contrast, if said clamp is joined to another identical clamp, each arm of both clamps will have thereon a first joining means arranged in a more proximal position of the support and a second joining means arranged in a more distal position than the first joining means, the first and second joining means having complementary coupling geometries, which allows them to be coupled to one another.

[0084] Said joining means can also be of different kinds, such as for example, lugs that can be inserted into cavities, jagged profiles, hooks, clips, etc.

[0085] Additionally, the cladding panels includes operable retainers having a retaining position in which they prevent the release of the coupling means with respect to the panels, and a release position in which they do not interfere with said coupling means.

[0086] Said retainers can be, by way of non-limiting illustrative example, a latch or a bolt coupled to the rear face of the panel which in the retaining position is partially superimposed on the support and prevents, alone or in combination with the coupling means, the separation of the panel with respect to said support.

[0087] The described securing device is envisaged for being secured around the previously described tubular element, which will preferably be a cylindrical extendable tubular element. Panels can be coupled to said securing device by means of the coupling means described above, the assembly of tubular element, securing device and panels creating a removable partition, divider or wall, said elements being parts making up a kit for erecting dividers.

[0088] Said kit for erecting walls therefore includes:

- a plurality of extendable props that can be fitted between two parallel planes;
- a plurality of securing devices that can be coupled to said extendable props; and
- a plurality of panels that can be coupled to said securing devices.

Each of the extendable props preferably comprises:

- at least one hollow tubular element provided with an upper end and a lower end defining a longitudinal direction;
- at least one threaded element partially housed inside the mentioned tubular element, attached to the tubular element by means of a coupling thread providing an adjustable insertion and/or extraction of said threaded element with respect to said tubular element, thereby increasing or reducing the total length of the extendable prop;
- at least one compressible elastic element susceptible of reducing the total length of the extendable prop since said extendable prop is subjected to axial com-

pression in the longitudinal direction, said elastic element being connected with a movable element, which moves in the axial longitudinal direction of the tubular element, offering elastic strength against said movement;

- the hollow tubular element is made up of a plurality of tubular segments with the same sized outer section arranged coaxial and coaligned with one another, said tubular segments being susceptible of being attached by means of at least one connecting element;
- the length of each of said tubular segments is less than three fourths the total length of the extendable prop in the extended position; and
- the mentioned coupling thread links the threaded element with one end of one of said tubular segments.

[0089] Each of said securing devices includes the described coupling means and preferably also the other features described up until now.

[0090] Each of said panels is rectangular and rigid and preferably includes:

a rectangular front face demarcated by an upper edge face, a lower edge face and two side edge faces, which in turn demarcate a rectangular rear face parallel to said front face;

each panel including on its rear face attachment configurations complementary with and envisaged for being coupled to the coupling means of the securing devices.

[0091] Said attachment configurations allow coupling the panels to the extendable props by means of the securing devices.

[0092] Optionally, operable retainers envisaged for retaining the coupling means in the attachment configurations of the panels in a retaining position are proposed.

[0093] Said attachment configurations preferably consist of grooves complementary with the coupling means of the securing devices, consisting of flanges, the flanges and the grooves being sized to achieve a tight-fitting insertion, or an insertion with a certain specific clearance. Said grooves will preferably be perpendicular to the rear face and parallel to the upper and lower edge faces and will be located in positions adjacent to said edge faces.

[0094] According to one embodiment, each panel has attachment configurations in its four corners, which allows holding said panel by means of the coupling thereof with four securing devices arranged in said corners and furthermore shared with other adjacent, contiguous and coplanar panels, such that each securing device holds a corner of two laterally adjacent panels or four laterally adjacent panels.

[0095] In one embodiment, said groove forming the attachment configuration of the panel is horizontal and runs from the side edge face to a certain distance away from said side edge face, being similarly repeated in the four

corners. By placing two panels laterally adjacent to one another, said grooves are aligned such that a coupling means envisaged in a securing device can be formed by a main flange which is simultaneously coupled in both grooves of two adjacent panels.

[0096] Additionally, the coupling means of the securing device can also have secondary flanges perpendicular to the main flanges which are coupled to secondary grooves also envisaged in the vicinity of the corners of the panel, making up the attachment configuration. This allows also securing the panel horizontally.

[0097] Furthermore, it is also contemplated that the upper and lower edge faces have a tongue and groove profile or have the shape of a step, which allows coupling between two vertically superimposed panels and assuring correct positioning of the panels, correct transmission of vertical loads from one panel to another, and preventing an individual panel from being able to be extracted horizontally. Said tongue and groove profile, in combination with an operable retainer which prevents extraction of the coupling means from the attachment configurations of the panel in a horizontal direction, will allow vertically transmitting loads and will prevent horizontal uncoupling of the panels with respect to the securing devices.

[0098] Other elements can also be optionally included in the kit, such as, for example, a base board element, an upper finishing element, a side finishing element, a door element, etc.

[0099] The base board element will be envisaged to be supported on a floor and to serve as a support for the panels of the divider or wall superimposed on said base board, which panels will in turn support the weight of the other panels superimposed thereon.

[0100] In contrast, the upper and side finishing elements will serve for securing the assembly of the wall or divider to already existing side walls and ceiling, and/or for adapting the removable divider or wall to possible flanges or reliefs existing in the already existing walls and ceiling.

[0101] The elements making up said kit form a system for erecting walls.

[0102] The elements making up the mentioned kit can therefore be assembled according to the following steps.

First, the tubular elements are fitted between a floor and a ceiling in a vertical position and separated from one another by a distance equal to the length of the panels. Base board elements can be installed on the floor following the base of the partition to be erected after installation of the props, or preferably before said installation of the props, which can be positioned by means of openings made on said base board elements into which the lower end of the tubular elements is inserted. The securing devices are then installed, joined to other securing devices, particularly the tubular elements to which the panels are to be secured. Finally, the panels are installed starting from the lower row, the lower end of which is coupled to the base board elements by means of a tongue and

groove or stepped configuration, and the upper end of which is anchored to securing devices of each tubular element located at the correct height to allow said coupling, the lower row of panels being coupled to the base board element. Said anchoring with the securing devices takes place by means of inserting the coupling means into the attachment configurations of the panel, and by means of operating the operable retainer which prevents the uncoupling thereof. The rows of successive panels are installed by coupling their lower end with the upper edge of the row of preceding panels by means of a tongue and groove or stepped configuration, and by coupling the upper end thereof to other securing devices attached to the tubular elements in a position allowing it to be similar to that described for the lower row. The operation is repeated until the wall is completely erected.

[0103] It will be understood that references to geometric positions, such as, for example, parallel, perpendicular, etc., allow deviations of up to $\pm 5^\circ$ with respect to the theoretical position defined by said wording.

[0104] Other features will be seen in the following detailed description of an embodiment.

Brief Description of the Drawings

[0105] The foregoing and other advantages and features will be better understood based on the following detailed description of an embodiment in reference to the attached drawings which must be interpreted in an illustrative and non-limiting manner, in which:

Figure 1 shows a side view of an extendable prop assembled and fitted between two parallel planes according to a first embodiment in which the plurality of tubular segments is formed by a first tubular element and a second tubular element;

Figure 2 shows an enlarged side view of the two ends of the extendable prop and the intermediate section provided with the attachment element and the threaded element according to the first embodiment;

Figure 3a shows a perspective view of the extendable prop according to the first embodiment, the first tubular element and the second tubular element being uncoupled, according to the first embodiment, the connecting element being a smooth axially fitted element;

Figure 3b shows a perspective view of the extendable prop, the first tubular element and the second tubular element being uncoupled, according to a second embodiment also formed by first and second tubular elements, the connecting element being a threaded element;

Figure 4a shows an exploded perspective view of the extendable prop according to the first embodiment;

Figure 4b shows an exploded perspective view of the extendable prop according to the second em-

bodiment;

Figure 5 shows a longitudinal section of the extendable prop assembled according to the first embodiment.

Figure 6 shows an axonometric view of a securing device and its relative position with respect to another identical securing device, to a tubular element and to four panels being shown in an exploded view;

Figure 7 shows an axonometric view of a securing device in a position coupled to a tubular element and to another identical securing device coupled to four panels;

Figure 8 shows a plan view of a securing device;

Figure 9 shows a front elevational view of a securing device;

Figure 10 shows a side elevational view of a securing device, along with a vertical section of two panels mutually coupled by means of a tongue and groove configuration, and a side elevational view of another securing device, uncoupled from the first device, facing two other mutually coupled panels, also showing the position of a base board element.

Detailed Description of an Embodiment

[0106] According to a non-limiting embodiment shown in Figure 1, the extendable prop 1 can be fitted between a floor and a parallel ceiling and comprises a plurality of tubular segments formed by a first tubular element 11 and a second tubular element 12, both being hollow and cylindrical, made of aluminum, and having the same inner and outer diameter. Their outer diameter is less than 6 cm, their wall is a few millimeters thick, and both the first and second tubular elements 11 and 12 have a length of about 110 cm, so the sum total does not exceed 220 cm. The length of the first and second tubular elements can be different from one another.

[0107] Both first and second tubular elements 11 and 12 can be coupled to and uncoupled from one another in the longitudinal direction by means of a connecting element 22 as shown in Figure 3, as a result of the attachment thereof the assembly forming a tubular element of the prop 2.

[0108] In this embodiment, the first tubular element 11 has at one of its ends a coupling thread 21 complementary with a threaded element 20. Said threaded element 20 is a hollow tube with one or more threads made on a portion of its outer face, which can be screwed onto and unscrewed from the female coupling thread 21 inserted and secured inside the end of the first tubular element 11. The threaded element 20 is thereby secured to the first tubular element 11 and can regulate the relative insertion and extraction thereof with respect to same by means of the threaded rotation thereof. By way of example, the threaded element 20 can have a thread length of 60 cm, which would allow varying the total length of the extendable prop 1 about 45 cm by means of the mentioned regulation, and it can have holes in the perimeter

thereof which allow inserting an extractable key that allows rotating the threaded element 20, exerting an angular force.

[0109] In this non-limiting embodiment, the end of the threaded element 20 which is not inserted into the first tubular element 11 has a connecting element 22 integrated therewith which allows the attachment thereof with an end of the second tubular element 12, thereby attaching the first and second tubular elements 11 and 12. In this first embodiment shown in Figures 3a and 4a, the connecting element 22 consists of a cylinder with an outer diameter equal to or less than the inner diameter of the second tubular element 12, such that it can be manually inserted therein in the longitudinal direction of the second tubular element 12. In a second alternative embodiment shown in Figures 3b and 4b, the connecting element consists of a coupling thread for coupling with the second tubular element 12 which would be provided with the corresponding coupling thread, for example, with a bushing 16 having a coupling thread, or a thread machined directly on the inner face of the second tubular element 12.

[0110] These first and second embodiments allow the threaded element 20 to be arranged in an intermediate position of the extendable prop 1, making it much more accessible to an operator, and making handling easier, but this element could obviously be arranged at one of the ends of the extendable prop 1.

[0111] A maximum insertion limiter 23 performs a limiting function with the threaded element 20 and the connecting element 22, preventing part of the threaded element 20 from being inserted into the second tubular element 12. This maximum insertion limiter 23 is an intermediate portion of the element with an outer diameter equal to the outer diameter of the second tubular element 12, therefore making the insertion thereof impossible. The mentioned maximum insertion limiter 23 can in turn have holes in which a lever which aids the rotation of the threaded element 20 with respect to the first tubular element 11 in inserted, thereby regulating the insertion or extraction thereof, and thereby regulating the total height of the tubular element of the prop 2 as a result of the attachment of the first and second tubular elements 11 and 12.

[0112] The second tubular element 12 has a movable element 24 partially inserted into one of its ends and attached thereto without preventing the movement of the second tubular element 12 in the longitudinal direction. This movable element 24 internally houses an elastic element 25 having an end secured to the second tubular element 12. This construction allows the movable element 24 to move in the longitudinal direction of the tubular element since it is subjected to a force, an elastic strength provided by the elastic element 25 resisting said movement.

[0113] According to one embodiment, the movable element 24 is a tubular element of the prop 2 having an outer diameter smaller than the inner diameter of the second tubular element 12, with a closed end. Inside the

movable element 24, a spring works as an elastic element 25, which spring has an end attached to the second tubular element 12 by means of a pin 26, for example.

[0114] Additionally, an indicator device 27 allows knowing the strain exerted by the spring, by means of, for example, a ruler measuring relative movement between the movable element 24 and the second tubular element 12, which allows knowing the strain of the elastic element 25 by means of Hooke's Law.

[0115] According to a preferred embodiment, the indicator device 27 is a screw 28 inserted perpendicularly in the tubular wall of the movable element 24, in the fraction of said movable element 24 inserted into the second tubular element 12, the head of said screw 28 projecting from the movable element 24, and preferably flush with the outer face of the second tubular element 12. Said head is fitted inside a longitudinal slot made on the cylindrical wall of the end of the second tubular element 12. Said head of the screw 28 thereby acts as a retainer of the movable element 24, preventing it from coming out of the second tubular element 12, while at the same time allowing its movement along the slot, and at the same time allowing an operator to see the position of the movable element 24 through the position of the head of the screw 28, also acting as an indicator device 27.

[0116] Like the free end of the first tubular element 11, the end of the movable element 24 is provided with an element having a high coefficient of friction 29 making it difficult for a force perpendicular to the extendable prop 1 to move it out of place since said extendable prop 1 is fitted against the ceiling and the floor by pressure.

[0117] Said element having a high coefficient of friction 29 can be assembled on a panel attached by means of a shaft with bearings to the end of a tubular element 11 or 12, or to the end of a movable element 24, or to the end of a threaded element 20, or a joint made of a material with a low coefficient of friction, such as Teflon, can be used to make rotation thereof easier.

[0118] Optionally, one or more third tubular elements 13 having a short length, provided with a coupling thread, can be arranged in the threaded segment of the threaded element 20 that is not housed inside the first tubular element 11. The longitudinal position of said third tubular element 13 on said segment can be regulated by means of the coupling thread. This allows it to be used for locking the position of the threaded element, tightening said third tubular element against the first tubular element 11 through the bushing 16 having a coupling thread, thereby locking the coupling thread, or allowing it to be located in any longitudinal position of said threaded element to serve as support for a possible securing device.

[0119] The extendable prop 1 of this embodiment has no element projecting from the plane formed by the outer cylindrical wall of the tubular element.

[0120] A plurality of those extendable props 1 can optionally be placed parallel to and equidistant from one another to subsequently support cladding made up of panels removably secured to said extendable props 1

through one or both faces by means of securing devices.

[0121] The combination of the extendable prop 1, the securing device and the cladding panels provide a partition system which allows erecting partitions in a simple, clean and removable manner, allowing them to be reused in a different place, and the packaging of the entire system being in a small and easy-to-transport packet.

[0122] A alternative embodiment (not shown) in which the plurality of tubular segments includes, in addition to the first and second tubular elements 11 and 12, additional tubular elements having the same features which can be connected to said first and second tubular elements 11 and 12 by means of additional connecting elements 22, thereby increasing the total maximum length of the extendable prop, is also contemplated.

[0123] According to a non-limiting embodiment shown in Figure 6, the prop includes a securing device 30 consisting of a clamp 31 formed by a first arm 32 and a second arm 33 arranged opposite one another, which are attached at their proximal end to a support 34 from which they project almost perpendicularly. The distal ends of both arms 32 and 33 are arranged opposite and spaced from one another, the distance of separation thereof being smaller than a width of a tubular element 2, the tubular element being an elongated element having a constant section along a longitudinal axis E, and being in this embodiment an extendable prop having a circular section that can be fitted between a floor and a ceiling.

[0124] Said distance of separation, together with the capacity of the arms of being elastically deformable, allows said clamp 31 to be coupled to and uncoupled from the tubular element 2 by exerting a force perpendicular to the longitudinal axis E, causing said elastic deformation of the arms, being attached to the tubular element 2 as shown in Figure 7 after the coupling thereof.

[0125] On a face opposite the face on which said arms are attached, said support 34 has coupling means 35, including a main flange 36 provided with two main faces perpendicular to the longitudinal axis of the tubular element, an additional flange 38 symmetrical to the main flange 36 with respect to a plane of symmetry perpendicular to the longitudinal axis and two secondary flanges 37 each with two faces parallel to the longitudinal axis, said two secondary flanges 37 being symmetrical with respect to a plane parallel to the longitudinal axis. Said coupling means 35 allow securing cladding panels 40 to said tubular element by means of said securing device, the panels 40 being parallel to the mentioned longitudinal axis E.

[0126] In the present embodiment, each main flange 36, additional flange 38 and secondary flange 37 has a rectangular section which is complementary with a corresponding main groove 46, additional groove 48 and secondary groove 47 made on the back of the cladding panels 40, as seen in Figure 6.

[0127] The flanges measure 3 mm wide and 4 mm high with respect to the support 34 and are arranged symmetrically with respect to a plane of symmetry perpendicular

to the longitudinal axis E, the securing device 30 being coupled to the tubular element 2.

[0128] Since the grooves 46, 47 and 48 are made on areas close to the corners of the panels 40, four corners of four different panels 40 can be anchored on one and the same securing device 30 by means of inserting said flanges 36, 37 and 38 into said grooves 46, 47 and 48, which allows securing said four panels 40 in a laterally adjacent and coplanar position. By installing a securing device 30 in each of the corners of each panel 40, cladding can be extended in all directions, while at the same time securing each of the panels 40.

[0129] To assure that said panels 40 do not uncouple from the coupling means, operable retainers 50 attached in a pivotable manner on the rear face of the panels have been envisaged, such that after coupling the panel to the securing device, the operation of said operable retainers 50 presses on and retains the coupling means 35 in the grooves envisaged on the rear face of the panel 40, as shown in Figure 7. To that end it is also contemplated that adjacent panels are laterally coupled by means of a tongue and groove configuration or a stepped configuration, as seen in Figure 10.

[0130] The proposed securing device 30 also includes joining means 39 which in the embodiment shown in Figures 6 and 7 consist of two joining means arranged in each of the first and second arms 32 and 33, there being four joining means in total.

[0131] There is envisaged in each arm a joining means 39 in the form of a projection and a joining means 39 complementary to said projecting shape; in the example shown, the projecting shape is a cylindrical or frustoconical lug, and the complementary shape is a cylindrical or frustoconical cavity.

[0132] When there is another securing device 30' identical to the described securing device 30, said joining means 39 allow both devices to be mutually coupled by means of the mutual coupling of their corresponding joining means 39 and 39'.

[0133] To mutually join the two securing devices 30 and 30', respective clamps 31 and 31' must be superimposed or juxtaposed, arranging the distal end of the first and second arms 32' and 33' of the other laterally adjacent securing device 30' on the proximal end of the first and second arms 32 and 33 of the initial securing device 30, and also arranging the proximal end of said arms of the other laterally adjacent securing device 30' on the distal end of the arms of the initial securing device 30.

[0134] By means of said juxtaposition, the arms and the joining means 39 and 39' of the two securing devices 30 and 30' are aligned, while at the same time respective supports 34 are arranged on opposite sides and the coupling means 35 are oriented towards opposite sides, securing the panels 40 parallel to one another on opposite sides of the tubular element 2 to which the mentioned securing devices 30 and 30' are secured.

[0135] The alignment of the joining means 39 and 39' of the two securing devices 30 and 30' allows their mutual

coupling by means of inserting cylindrical lugs into cylindrical cavities in the example herein illustrated.

[0136] In the illustrated example, the joining means 39 of the first arm 32 of the securing device 30 are coupled to the joining means 39' of the first arm 32' of the other securing device 30', and the joining means of the second arm 33 are coupled to the joining means of the other second arm 33'. That is only possible if the position of the other securing device 30' is inverted with respect to the position of the initial securing device 30.

[0137] The cylindrical lugs are inserted into the cylindrical cavities in a direction parallel to the longitudinal axis E of the tubular element 2, the securing devices 30 and 30' being coupled to said tubular element 2, said direction of coupling being perpendicular to the direction of coupling of the securing devices 30 and 30' to the tubular element 2. This means that when the joining means 39 and 39' are mutually coupled, the securing devices 30 and 30' cannot be uncoupled from the tubular element 2 since they form a casing around the tubular element 2 and the joining means 39 and 39' prevent relative movement between both securing devices in that direction.

Claims

1. A kit for erecting walls including:

- a plurality of extendable props (1) that can be fitted against two parallel planes, each prop (1) comprising:
 - o at least one hollow tubular element (2), provided with an upper end and a lower end, defining a longitudinal direction, the hollow tubular element (2) being made up of a plurality of tubular segments with the same sized outer section arranged coaxial and coaligned with one another, said tubular segments being susceptible of being attached by means of at least one connecting element (22), and each having a length less than three fourths the total length of the extendable prop (1) in the extended position;
 - o at least one threaded element (20) partially housed inside the mentioned tubular element (2), attached to the tubular element (2) by means of a coupling thread (21) providing an adjustable insertion and/or extraction of said threaded element (20) with respect to said tubular element (2), thereby increasing or reducing the total length of the extendable prop (1), the mentioned coupling thread (21) linking the threaded element (20) with one end of one of said tubular segments;
 - o at least one compressible elastic element

5
10
15
20
25
30
35
40
45
50
55

(25) susceptible of reducing the total length of the extendable prop (1) since said extendable prop (1) is subjected to axial compression in the longitudinal direction, said elastic element (25) being connected with a movable element (24), which moves in the longitudinal axial direction of the tubular element (2), offering elastic strength against said movement;

- o at least one indicator device (27) which indicates the amount of elastic force exerted by said elastic element (25) when subjected to compression;

- a plurality of securing devices (30,30') for removably securing cladding panels (40) to extendable props (1);
- a plurality of cladding panels (40) that can be coupled to said securing devices (30);

characterized in that said securing device (30) for removably securing cladding panels (40) to tubular elements (2) comprises:

- a clamp (31) having a first arm (32) and a second arm (33) that are elastically deformable and arranged opposite one another, both arms (32 and 33) being provided with a proximal end and a distal end, the proximal ends of the first and second arms (32 and 33) being attached to a support (34), and the distal ends of the first and second arms (32 and 33) being arranged opposite and spaced from one another, said distance being smaller than a width measurement of a tubular element (2), and the clamp (31) being able to be coupled to and decoupled from said tubular element (2) by means of elastic deformation of said first and second arms (32, 33) under pressure;
- at least one coupling means (35) arranged in said support (34), to which at least one cladding panel (40) can be removably secured; and the tubular element (2) being a linear element elongated in the direction of a longitudinal axis (E); and **in that**
- at least one joining means (39) arranged in at least one of the first and second arms (32, 33), said joining means (39) being able to be coupled to another joining means (39') of another securing device (30') complementary to the securing device (30), said other securing device (30') including another joining means (39'), another support (34') and other coupling means (35'), the coupled assembly of both securing devices (30, 30') forming a tight-fitting casing around the tubular element (2).

2. The kit according to claim 1, wherein said other se-

- curing device (30') is identical to the initially described securing device (30) and includes a first arm and a second arm (32', 33'), and said securing device (30) being coupled to another securing device (30'), the proximal part of the first and second arms (32, 33) of the securing device (30) being juxtaposed with respect to the distal part of the first and second arms (32', 33') of the other securing device (30').
- 5
3. The kit according to claim 1 or 2, wherein the direction of coupling and uncoupling the joining means (39) of the securing device (30) with respect to the joining means (39') of the other securing device (30') is approximately parallel to the longitudinal axis (E) of the tubular element (2), the clamp (31) being coupled to said tubular element (2).
- 10
4. The kit according to any of the preceding claims 1 to 3, wherein:
- 15
- the coupling means (35) of the support (34) has a configuration allowing simultaneous coupling of at least two laterally adjacent and coplanar panels (40), the coupling means (35) being symmetrical with respect to a vertical, parallel and coinciding plane of symmetry with respect to the longitudinal axis (E), the clamp (31) being in a coupling position.
- 20
5. The kit according to claim 4, wherein:
- 25
- with the securing device (30) being coupled to the other securing device (30'), the mentioned horizontal plane of symmetry of the coupling means (35) of the support (34) is coplanar with another horizontal plane of symmetry of the other coupling means (35') of the other support (34') of the other securing device (30'); and/or
 - the coupling means (35) includes a horizontally elongated main flange (36) having a constant section, provided with two main faces perpendicular to the longitudinal axis (E) in the coupling position, said main flange (36) being complementary to a main groove (46) made on the rear face of the panels (40), wherein the main flange (36) optionally measures 3 mm wide and projects 4 mm from the support (34).
- 30
6. The kit according to claim 5, wherein the coupling means (35) further includes:
- 35
- two vertically elongated secondary flanges (37), each provided with two faces parallel to the longitudinal axis (E) in the coupling position, said two secondary flanges (37) being complementary to two secondary grooves (47) made on the rear faces of the panels (40); and
 - a horizontally elongated additional flange (38),
- 40
- 45
- 50
- 55
- provided with two faces perpendicular to the longitudinal axis (E) in the coupling position, said additional flange (38) being complementary to an additional groove (48) made on the rear face of the panels (40);
- wherein the secondary flanges (37) and/or the additional flange (38) optionally measure 3 mm wide and project 4 mm from the support (34).
7. The kit according to any one of the preceding claims 1 to 6, wherein the securing devices (30) include one or more of the following features:
- each first arm (32) and second arm (33) consists of two joining means (39), a first joining means being arranged in a more proximal position of the support (34) and a second joining means being arranged in a more distal position than the first joining means, the first and second joining means having complementary coupling geometries;
 - the coupling means (35) of the support (34) are configured so that the panels (40) secured to said coupling means (35) are arranged in a plane parallel to the longitudinal axis (E), the clamp (31) being anchored to the tubular element (2).
8. The kit according to claim 1, wherein said cladding panels (40) are rigid rectangular panels, each provided with a rectangular front face demarcated by an upper edge face, a lower edge face and two side edge faces which in turn demarcate a rectangular rear face parallel to said front face, each panel including on its rear face:
- attachment configurations complementary with, and envisaged for being coupled to, the coupling means of the securing devices in combination with operable retainers (50) envisaged for retaining the coupling means (35) in the attachment configurations of the panels (40), being in a retaining position; and/or
 - attachment configurations complementary with, and envisaged for being coupled to, the coupling means of the securing devices consisting of grooves complementary with the coupling means (35) of the securing devices (30), consisting of flanges, the flanges and grooves being sized to achieve a tight-fitting insertion, or an insertion with a certain specific clearance; and/or
 - said panels have on their laterally adjacent and/or superimposed edge faces a tongue and groove coupling means envisaged on their faces arranged mutually opposite one another.

9. The kit according to any preceding claim, wherein said movable element (24) included in each prop (1) includes one or more of the following features:
- it is linked to one end of one of said tubular segments; 5
 - it is integrated with the threaded element (20);
 - it is integrated with the connecting element (22). 10
10. The kit according to any preceding claim, wherein an element having a high coefficient of friction (29) is linked to an end of a tubular segment, and another element having a high coefficient of friction (29) is linked to an end of another tubular segment. 15
11. The kit according to claim 10 wherein said linkage of the element having a high coefficient of friction (29) with the end of a tubular segment is made by means of: 20
- a rotary attachment (14) allowing relative rotation with respect to the axial axis of the element having a high coefficient of friction (29) with respect to the tubular segment; or 25
 - a rotary attachment (14) allowing relative rotation with respect to the axial axis of the element having a high coefficient of friction (29) with respect to the tubular segment and integrating a threaded regulator allowing the relative longitudinal axial movement between the element having a high coefficient of friction (29) and the tubular segment, by means of screwing on or unscrewing said threaded regulator. 30
12. The kit according to claim 10 or 11, wherein at least one of the elements having a high coefficient of friction (29) is integrated with the threaded element (20) or the movable element (24). 35
13. The kit according to any one of the preceding claims, wherein said indicator device (27) is a ruler which allows measuring relative movement between the movable element (24) and the tubular segment where it is housed. 40
14. The kit according to any preceding claim, wherein the plurality of tubular segments are a first tubular element (11) and a second tubular element (12); 45
15. The kit according to any one of the preceding claims, wherein each prop (1) also includes one or more of the following features: 50
- the tubular segments are cylindrical; 55
 - said connecting element (22) is integrated with the threaded element (20);
 - no element of the extendable prop (1) projects

from the plane defined by the outer perimeter of the tubular segments;

- at least a third tubular element (13) provided with a coupling thread is coupled to an intermediate portion of the threaded element (20), not inserted into any of the tubular segments, and in that said at least third tubular element (13) moves in the longitudinal direction of the threaded element (20) by means of the operation caused by the threaded rotation of the third tubular element (13);
- the tubular element (2) of the prop has transverse through holes;
- said maximum insertion limiter (23) is a central portion arranged between the connecting element (20) and the threaded element (22), the maximum insertion limiter (23) having a larger outer section than the inner cavity of the tubular elements to be connected.

Patentansprüche

1. Kit zum Stellen von Wänden beinhaltend:

- eine Vielzahl von ausziehbaren Stützen (1), welche gegen zwei parallelen Ebenen angebracht werden können, wobei jede Stütze (1) Folgendes umfasst:

o mindestens ein hohles rohrförmiges Element (2), welches mit einem oberen Ende und einem unteren Ende versehen ist, welche eine Längsrichtung definieren, wobei das hohle rohrförmige Element (2) aus einer Vielzahl von rohrförmigen Segmenten mit einem äußeren Querschnitt mit der gleichen Größe gebildet ist, welche koaxial und zueinander fluchtend angeordnet sind, wobei die genannten rohrförmigen Segmente in der Lage sind, mittels mindestens eines Anschlusselementes (22) befestigt zu werden, und wobei jedes eine Länge aufweist, welche kleiner als drei Viertel der Gesamtlänge der ausziehbaren Stütze (1) in der ausgezogenen Stellung ist;

o mindestens ein Gewindeelement (20), welches teilweise innerhalb des erwähnten rohrförmigen Elementes (2) aufgenommen ist, welches mittels eines Kopplungsgewindes (21) am rohrförmigen Element (2) befestigt ist, so dass eine einstellbare Einfügung und/oder Entnahme des genannten Gewindeelementes (20) in Bezug auf das genannte rohrförmige Element (2) bereitgestellt wird, wodurch die Gesamtlänge der ausziehbaren Stütze (1) erhöht oder verringert wird, wobei das erwähnte Kopplungs-

gewinde (21) das Gewindeelement (20) mit einem Ende eines der genannten rohrförmigen Segmente verbindet;

o mindestens ein zusammendrückbares elastisches Element (25), welches in der Lage ist, die Gesamtlänge der ausziehba- 5 ren Stütze (1) zu verringern, da die genann- te ausziehbare Stütze (1) einer axialen Zu- sammendrückung in Längsrichtung unter- zogen wird, wobei das genannte elastische Element (25) an einem beweglichen Ele- 10 ment (24) angeschlossen wird, welches sich in der axialen Längsrichtung des rohr- förmigen Elementes (2) bewegt, wobei ein elastischer Widerstand gegen die genannte Bewegung geleistet wird;

o mindestens eine Anzeigevorrichtung (27), welche die Menge von elastischer Kraft, welche vom genannten elastischen Ele- 20 ment (25) ausgeübt wird, anzeigt, wenn es einer Zusammendrückung unterzogen wird;

- eine Vielzahl von Fixierungsvorrichtungen (30, 30') zum lösbaren Fixieren von Verkleidungs- 25 platten (40) an ausziehbaren Stützen (1);
- eine Vielzahl von Verkleidungsplatten (40), welche mit den genannten Fixierungsvorrich- 30 tungen (30) gekoppelt werden können;

dadurch gekennzeichnet, dass die genannte Fi- xierungsvorrichtung (30) zum lösbaren Fixieren von Verkleidungsplatten (40) an rohrförmigen Elemen- 35 ten (2) Folgendes umfasst:

- eine Klemme (31), welche einen ersten Arm (32) und einen zweiten Arm (33) aufweist, wel- 40 che elastisch verformbar und einander gegen- überliegend angeordnet sind, wobei beide Arme (32 und 33) mit einem proximalen Ende und einem distalen Ende versehen sind, wobei die pro- ximalen Enden des ersten und des zweiten Ar- 45 mes (32 und 33) an einer Halterung (34) befestigt sind, und wobei die distalen Enden des ers- ten und des zweiten Armes (32 und 33) gegen- überliegend und voneinander beabstandet ange- ordnet sind, wobei der genannte Abstand kleiner als eine Breitenmessung eines rohrförmigen Elementes (2) ist, und wobei die Klemme (31) in der Lage ist, mittels elastischer Verformung des genannten ersten und zweites Armes (32, 33) unter Druck mit dem genannten rohrförmigen Element (2) gekoppelt und davon entkop- 50 pelt zu werden;
- mindestens ein Kopplungsmittel (35), welches in der genannten Halterung (34) angeordnet ist, an welchem mindestens eine Verkleidungsplat- 55 te (40) lösbar fixiert werden kann; und wobei das

rohrförmige Element (2) ein lineares Element ist, welches in die Richtung einer Längsachse (E) langgestreckt ist; und

• mindestens ein Fügungsmittel (39), welches in mindestens einem des ersten und des zweiten Armes (32, 33) angeordnet ist, wobei das ge- 5 nannte Fügungsmittel (39) in der Lage ist, mit einem anderen Fügungsmittel (39') einer ande- ren Fixierungsvorrichtung (30'), welche komple- 10 mentär zur Fixierungsvorrichtung (30) ist, gekoppelt zu werden, wobei die genannte andere Fixierungsvorrichtung (30') ein anderes Fügungsmittel (39'), eine andere Halterung (34') und ein anderes Kopplungsmittel (35') beinhaltet, wobei die gekoppelte Baugruppe aus beiden Fixierungsvorrichtungen (30, 30') ein eng anlie- 15 gendes Gehäuse um das rohrförmige Element (2) herum bildet.

2. Kit nach Anspruch 1, wobei die genannte andere Fi- xierungsvorrichtung (30') identisch mit der anfäng- 20 lich beschriebenen Fixierungsvorrichtung (30) ist und einen ersten Arm und einen zweiten Arm (32', 33') beinhaltet, und wobei die genannte Fixierungs- vorrichtung (30) mit einer anderen Fixierungs- vorrichtung (30') gekoppelt ist, wobei der proximale Teil des ersten und des zweiten Armes (32, 33) der Fi- xierungsvorrichtung (30) in Bezug auf den distalen Teil des ersten und des zweiten Armes (32', 33') der 25 anderen Fixierungsvorrichtung (30') nebeneinan- dergestellt sind.

3. Kit nach Anspruch 1 oder 2, wobei die Richtung der Kopplung und Entkopplung des Fügungsmittels (39) der Fixierungsvorrichtung (30) in Bezug auf das Fügungsmittel (39') der anderen Fixierungsvorrichtung (30') etwa parallel zur Längsachse (E) des rohrförmigen Elementes (2) ist, wobei die Klemme (31) mit dem genannten rohrförmigen Element (2) gekoppelt 35 ist.

4. Kit nach einem der vorhergehenden Ansprüche 1 bis 3, wobei:

- das Kopplungsmittel (35) der Halterung (34) eine Ausbildung aufweist, welche die gleichzei- 40 tige Kopplung von mindestens zwei seitlich be- nachbarten und komplanaren Platten (40) er- laubt, wobei das Kopplungsmittel (35) in Bezug auf eine vertikale, parallele und übereinstim- mende Symmetrieebene in Bezug auf die Längsachse (E) symmetrisch ist, wobei die Klemme (31) in einer Kopplungsposition ist.

5. Kit nach Anspruch 4, wobei:

- mit der Fixierungsvorrichtung (30) mit der ande- 55 ren Fixierungsvorrichtung (30') gekoppelt, die

erwähnte horizontale Symmetrieebene des Kopplungsmittels (35) der Halterung (34) komplanar mit einer anderen horizontalen Symmetrieebene des anderen Kopplungsmittels (35') der anderen Halterung (34') der anderen Fixierungsvorrichtung (30') ist; und/oder

- das Kopplungsmittel (35) einen horizontal langgestreckten Hauptflansch (36) beinhaltet, welcher einen konstanten Querschnitt aufweist, welcher mit zwei Hauptflächen senkrecht zur Längsachse (E) in der Kopplungsposition versehen ist, wobei der genannte Hauptflansch (36) komplementär zu einer Hauptnut (46) ist, welche auf der hinteren Fläche der Platten (40) hergestellt ist, wobei der Hauptflansch (36) wahlweise 3 mm in der Breite misst und 4 mm aus der Halterung (34) hervorsticht.

6. Kit nach Anspruch 5, wobei das Kopplungsmittel (35) zusätzlich Folgendes beinhaltet:

- zwei vertikal langgestreckte sekundäre Flansche (37), welche jeweils mit zwei Flächen parallel zur Längsachse (E) in der Kopplungsposition versehen sind, wobei die genannten zwei sekundären Flansche (37) komplementär zu zwei sekundären Nuten (47) sind, welche auf den hinteren Flächen der Platten (40) hergestellt sind; und

- einen horizontal langgestreckten zusätzlichen Flansch (38), welcher mit zwei Flächen senkrecht zur Längsachse (E) in der Kopplungsposition versehen ist, wobei der genannte zusätzliche Flansch (38) komplementär zu einer zusätzlichen Nut (48) ist, welche auf der hinteren Fläche der Platten (40) hergestellt ist;

wobei die sekundären Flansche (37) und/oder der zusätzliche Flansch (38) wahlweise 3 mm in der Breite messen und 4 mm aus der Halterung (34) hervorstehen.

7. Kit nach einem der vorhergehenden Ansprüche 1 bis 6, wobei die Fixierungsvorrichtungen (30) eines oder mehrere der folgenden Merkmale beinhalten:

- jeder erste Arm (32) und zweite Arm (33) besteht aus zwei Fügungsmitteln (39), wobei ein erstes Fügungsmittel in einer weiter proximalen Position der Halterung (34) angeordnet ist und ein zweites Fügungsmittel in einer weiter distalen Position als das erste Fügungsmittel angeordnet ist, wobei das erste und zweite Fügungsmittel komplementäre Kopplungsgeometrien aufweisen;

- die Kopplungsmittel (35) der Halterung (34) derart ausgebildet sind, dass die am genannten Kopplungsmittel (35) fixierten Platten (40) in ei-

ner zur Längsachse (E) parallelen Ebene angeordnet sind, wobei die Klemme (31) im rohrförmigen Element (2) verankert ist.

8. Kit nach Anspruch 1, wobei die genannten Verkleidungsplatten (40) starre rechteckige Platten sind, welche jeweils mit einer rechteckigen Stirnfläche versehen sind, welche von einer oberen Randfläche, einer unteren Randfläche und zwei seitlichen Randflächen begrenzt ist, welche wiederum eine rechteckige hintere Fläche parallel zur genannten Stirnfläche begrenzen, wobei jede Platte auf deren hinteren Fläche Folgendes beinhaltet:

- Befestigungsausbildungen, komplementär zu, und vorgesehen zur Kopplung mit, den Kopplungsmitteln der Fixierungsvorrichtungen in Kombination mit bedienbaren Arretierungen (50), welche dazu vorgesehen sind, die Kopplungsmittel (35) in den Befestigungsausbildungen der Platten (40) zu arretieren, wobei sie in einer Arretierungsposition sind; und/oder

- Befestigungsausbildungen, komplementär zu, und vorgesehen zur Kopplung mit, den Kopplungsmitteln der Fixierungsvorrichtungen bestehend aus Nuten komplementär zu den Kopplungsmitteln (35) der Fixierungsvorrichtungen (30), welche aus Flanschen bestehen, wobei die Flansche und Nuten bemessen sind, um eine eng anliegende Einfügung, oder eine Einfügung mit einem bestimmten spezifischen Spiel zu erreichen; und/oder

- die genannten Platten auf deren seitlich benachbarten und/oder übereinanderliegenden Randflächen ein Feder- und Nutkopplungsmittel aufweisen, welches auf deren gegenseitig einander gegenüberliegenden Flächen angeordnet vorgesehen ist.

9. Kit nach einem vorhergehenden Anspruch, wobei das genannte, in jeder Stütze (1) beinhaltete, bewegliche Element (24) eines oder mehrere der folgenden Merkmale beinhaltet:

- es ist mit einem Ende eines der genannten rohrförmigen Segmente verbunden;

- es ist mit dem Gewindeelement (20) integriert;

- es ist mit dem Anschlusselement (22) integriert.

10. Kit nach einem vorhergehenden Anspruch, wobei ein Element, welches einen hohen Reibungskoeffizienten (29) aufweist, mit einem Ende eines rohrförmigen Segmentes verbunden ist, und ein anderes Element, welches einen hohen Reibungskoeffizienten (29) aufweist, mit einem Ende eines anderen rohrförmigen Segmentes verbunden ist.

11. Kit nach Anspruch 10, wobei die genannte Verbindung des Elementes, welches einen hohen Reibungskoeffizienten (29) aufweist, mit dem Ende eines rohrförmigen Segmentes mittels Folgenden hergestellt wird: 5
- einer rotierenden Befestigung (14), welche eine relative Rotation in Bezug auf die axiale Achse des Elementes, welches einen hohen Reibungskoeffizienten (29) in Bezug auf das rohrförmige Segment aufweist, erlaubt; oder 10
 - einer rotierenden Befestigung (14), welche eine relative Rotation in Bezug auf die axiale Achse des Elementes, welches einen hohen Reibungskoeffizienten (29) in Bezug auf das rohrförmige Segment aufweist, erlaubt und welche einen Gewinderegler integriert, welcher die relative axiale Längsbewegung zwischen dem Element, welches einen hohen Reibungskoeffizienten (29) aufweist, und dem rohrförmigen Segment, mittels Einschraubens oder Losschraubens des genannten Gewindereglers erlaubt. 15
12. Kit nach Anspruch 10 oder 11, wobei mindestens eines der Elemente, welche einen hohen Reibungskoeffizienten (29) aufweisen, mit dem Gewindeelement (20) oder dem beweglichen Element (24) integriert ist. 25
13. Kit nach einem der vorhergehenden Ansprüche, wobei die genannte Anzeigevorrichtung (27) ein Lineal ist, welches das Messen einer relativen Bewegung zwischen dem beweglichen Element (24) und dem rohrförmigen Segment, in welchem es aufgenommen ist, erlaubt. 30
14. Kit nach einem vorhergehenden Anspruch, wobei die Vielzahl von rohrförmigen Segmenten ein erstes rohrförmiges Element (11) und ein zweites rohrförmiges Element (12) sind. 35
15. Kit nach einem der vorhergehenden Ansprüche, wobei jede Stütze (1) auch eines oder mehrere der folgenden Merkmale beinhaltet: 40
- die rohrförmigen Segmente sind zylindrisch; 45
 - das genannte Anschlusselement (22) ist mit dem Gewindeelement (20) integriert;
 - kein Element der ausziehbaren Stütze (1) steht aus der Ebene hervor, welche vom Außenumfang der rohrförmigen Segmente definiert wird; 50
 - mindestens ein drittes rohrförmiges Element (13), welches mit einem Kopplungsgewinde versehen ist, ist mit einem Zwischenteil des Gewindeelementes (20) gekoppelt, nicht in einem der rohrförmigen Segmente eingefügt, und das genannte mindestens dritte rohrförmige Element 55

(13) bewegt sich in Längsrichtung des Gewindeelementes (20) mittels des Betriebs, welcher von der gewindeartigen Rotation des dritten rohrförmigen Elementes (13) verursacht wird;

- das rohrförmige Element (2) der Stütze weist querlaufende Durchgangsbohrungen auf;
- der genannte maximale Einfügbegrenzer (23) ist ein mittiger Teil, welcher zwischen dem Anschlusselement (20) und dem Gewindeelement (22) angeordnet ist, wobei der maximale Einfügbegrenzer (23) einen größeren äußeren Querschnitt als der innere Hohlraum der anzuschließenden rohrförmigen Elemente aufweist.

Revendications

1. Un kit pour construire des murs comprenant :

- une pluralité de soutiens extensibles (1) pouvant être fixés contre deux plans parallèles, chaque soutien (1) comportant :
 - au moins un élément tubulaire creux (2), pourvu d'une extrémité supérieure et d'une extrémité inférieure, définissant un sens longitudinal, l'élément tubulaire creux (2) étant composé d'une pluralité de segments tubulaires ayant la coupe extérieure de la même taille aménagés coaxiaux et alignés entre eux, ces segments tubulaires étant susceptibles d'être reliés au moyen d'au moins un élément de connexion (22) et chacun ayant une longueur inférieure à trois quarts de la longueur totale du soutien extensible (1) en position déployée ;
 - au moins un élément fileté (20) en partie logé à l'intérieur de cet élément tubulaire (2), fixé à l'élément tubulaire (2) au moyen d'un filetage de couplage (21) fournissant une insertion et/ou extraction ajustable de cet élément fileté (20) par rapport à cet élément tubulaire (2), en augmentant ou réduisant ainsi la longueur totale du support extensible (1), ce filetage de couplage (21) reliant l'élément fileté (20) à une extrémité d'un de ces segments tubulaires ;
 - au moins un élément élastique compressible (25) susceptible de réduire la longueur totale du soutien extensible (1) car ce soutien extensible (1) est soumis à la compression axiale dans le sens longitudinal, cet élément élastique (25) étant connecté à un élément mobile (24), qui se déplace dans le sens axial longitudinal de l'élément tubulaire (2), en offrant une résistance élastique pour contrecarrer ce mouvement ;

◦ au moins un dispositif indicateur (27) indiquant la quantité de force élastique exercée par cet élément élastique (25) lorsqu'il est soumis à une compression ;

- une pluralité de dispositifs de sécurité (30, 30') pour fixer, amovibles, les panneaux de revêtement (40) aux soutiens extensibles (1) ;
- une pluralité de panneaux de revêtement (40) pouvant être couplés à ces dispositifs de sécurité (30) ;

caractérisé en ce que ce dispositif de sécurité (30) pour fixer, amovibles, les panneaux de revêtement (40) aux éléments tubulaires (2) comporte :

- un crampon (31) ayant un premier bras (32) et un deuxième bras (33) qui sont élastiquement déformables et aménagés l'un en face de l'autre, les deux bras (32 et 33) étant pourvus d'une extrémité proximale et d'une extrémité distale, les extrémités proximales des premier et deuxième bras (32 et 33) étant fixées à un support (34), et les extrémités distales des premier et deuxième bras (32 et 33) étant aménagées se faisant face et écartées entre elles, cet écart étant inférieur à une mesure de la largeur d'un élément tubulaire (2), et le crampon (31) étant apte pour être couplé et découplé de cet élément tubulaire (2) au moyen de déformation élastique de ces premier et deuxième bras (32, 33) sous pression ;
- au moins un moyen de couplage (35) aménagé sur ce support (34), auquel au moins un panneau de revêtement (40) peut être fixé, amovible ; et l'élément tubulaire (2) étant un élément linéaire allongé dans le sens d'un axe longitudinal (E) ; et **en ce qu'**
- au moins un moyen de jonction (39) aménagé sur au moins une des premier et deuxième bras (32, 33), ce moyen de jonction (39) étant apte pour être couplé à un autre moyen de jonction (39') d'un autre dispositif de sécurité (30') complémentaire de ce dispositif de sécurité (30), cet autre dispositif de sécurité (30') comprenant un autre moyen de jonction (39'), un autre support (34') et un autre moyen de couplage (35'), l'ensemble couplé des deux dispositifs de sécurité (30, 30') formant un carter bien ajusté autour de l'élément tubulaire (2).

2. Le kit conformément à la revendication 1, dans lequel ce dispositif de sécurité (30') est identique au dispositif de sécurité initialement décrit (30) et comprend un premier et un deuxième bras (32', 33') et ce dispositif de sécurité (30) étant couplé à un autre dispositif de sécurité (30'), la partie proximale des premier et deuxième bras (32, 33) du dispositif de

sécurité (30) étant juxtaposé par rapport à la partie distale des premier et deuxième bras (32', 33') de l'autre dispositif de sécurité (30').

- 5 3. Le kit conformément à la revendication 1 ou 2, dans lequel le sens de couplage et de découplage du moyen de jonction (39) du dispositif de sécurité (30) par rapport au moyen de jonction (39') de l'autre dispositif de sécurité (30') est approximativement parallèle à l'axe longitudinal (E) de l'élément tubulaire (2), le crampon (31) étant couplé à cet élément tubulaire (2).

- 10 4. Le kit conformément à une quelconque des revendications précédentes 1 à 3, dans lequel :

- le moyen de couplage (35) du support (34) possède une configuration permettant de coupler simultanément au moins deux panneaux (40) latéralement adjacents et coplanaires, le moyen de couplage (35) étant symétrique par rapport à un plan de symétrie vertical parallèle et coïncidant par rapport à l'axe longitudinal (E), le crampon (31) étant en position de couplage.

- 15 5. Le kit, conformément à la revendication 4, dans lequel :

- le dispositif de sécurité (30) étant couplé à l'autre dispositif de sécurité (30'), ce plan de symétrie horizontal du moyen de couplage (35) du support (34) est coplanaire à un autre plan de symétrie horizontal de l'autre moyen de couplage (35') de l'autre support (34') de l'autre dispositif de sécurité (30') ; et/ou
- le moyen de couplage (35) comprend une bride principale (36) allongée horizontalement ayant une coupe constante, pourvue de deux faces principales perpendiculaires à l'axe longitudinal (E) dans la position couplée, cette bride principale (36) étant complémentaire d'une rainure principale (46) réalisée sur la face arrière des panneaux (40), dans lequel la bride principale (36) mesure optionnellement 3 mm de large et dépasse le support (34) de 4 mm.

- 20 6. Le kit conformément à la revendication 5, dans lequel le moyen de couplage (35) comprend en plus :

- deux brides secondaires (37) allongées verticalement, chacune pourvue de deux faces parallèles à l'axe longitudinal (E) dans la position de couplage, ces deux brides secondaires (37) étant complémentaires de deux rainures secondaires (47) réalisées sur les faces arrière des panneaux (40), et
- une bride supplémentaire (38) allongée horizontalement, pourvue de deux faces perpendi-

culaires à l'axe longitudinal (E) dans la position de couplage, cette bride supplémentaire (38) étant complémentaires d'une rainure supplémentaire (48) réalisée sur la face arrière des panneaux (40) ;

dans lequel les brides secondaires (37) et/ou la bride supplémentaire (38) mesurent optionnellement 3 mm de large et dépassent le support (34) de 4 mm.

7. Le kit conformément à une quelconque des revendications précédentes 1 à 6, dans lequel les dispositifs de sécurité (30) comprennent une ou plusieurs des particularités suivantes :

- chacun des premier bras (32) et deuxième bras (33) consiste en deux moyens de jonction (39), un premier moyen de jonction étant aménagé dans une position plus proximale du support (34) et un deuxième moyen de jonction étant aménagé dans une position plus distale que le premier moyen de jonction, les premier et deuxième moyens de jonction ayant des géométries de couplage complémentaires ;

- le moyen de couplage (35) du support (34) est configuré de sorte que les panneaux (40) fixés sur ce moyen de couplage (35) sont aménagés sur un plan parallèle à l'axe longitudinal (E), le crampon (31) étant ancré sur l'élément tubulaire (2).

8. Le kit conformément à la revendication 1, dans lequel ces panneaux de revêtement (40) sont des panneaux rectangulaires rigides, chacun pourvu d'une face avant rectangulaire délimitée par une face de bord de bord supérieure, une face de bord inférieure et deux faces de bord latérales qui, à leur tour, délimitent une face arrière rectangulaire parallèle à cette face avant, chaque panneau comprenant sur sa face arrière :

- des configurations complémentaires de fixation ayant, et envisagées pour être couplées au moyen de couplage des dispositifs de sécurité en combinaison avec des arrêteurs actionnables (50) envisagés pour retenir les moyens de couplage (35) dans les configurations de fixation des panneaux (40), étant en position de rétention ; et/ou

- des configurations complémentaires de fixation ayant, et envisagées pour être couplées à au moyen de couplage des dispositifs de sécurité consistant en des rainures complémentaires au moyen de couplage (35) des dispositifs de sécurité (30), consistant en des brides, les brides et les rainures ayant une taille permettant une insertion très ajustée ou une insertion ayant un certain décalage spécifique ; et/ou

- ces panneaux possèdent sur leurs faces de bord latéralement adjacentes et/ou superposées, un moyen de couplage à rainures et languettes envisagé sur leurs faces aménagées se faisant mutuellement face.

5

10

15

20

25

30

35

40

45

50

55

9. Le kit conformément à une quelconque des revendications précédentes, dans lequel cet élément mobile (24) compris dans chaque soutien (1) comprend une ou plusieurs des particularités suivantes :

- il est relié à une extrémité d'un de ces segments tubulaires ;
- il est intégré dans l'élément fileté (20) ;
- il est intégré dans l'élément de connexion (22).

10. Le kit conformément à une quelconque des revendications précédentes, dans lequel un élément ayant un coefficient élevé de friction (29) est relié à une extrémité d'un segment tubulaire, et un autre élément ayant un coefficient élevé de friction (29) est relié à une extrémité d'un autre segment tubulaire.

11. Le kit conformément à la revendication 10, dans lequel ce lien de l'élément ayant un coefficient élevé de friction (29) à l'extrémité d'un segment tubulaire est effectué au moyen de :

- un accessoire rotatif (14) permettant une rotation relative par rapport à l'axe axial de l'élément ayant un coefficient élevé de friction (29) par rapport au segment tubulaire ; ou
- un accessoire rotatif (14) permettant la rotation relative par rapport à l'axe axial de l'élément ayant un coefficient élevé de friction (29) par rapport au segment tubulaire et intégrant un régulateur fileté permettant le mouvement axial longitudinal relatif entre l'élément ayant un coefficient élevé de friction (29) et le segment tubulaire au moyen du vissage ou dévissage de ce régulateur fileté.

12. Le kit conformément à la revendication 10 ou 11, dans lequel au moins un des éléments ayant un coefficient élevé de friction (29) est intégré à l'élément fileté (20) ou à l'élément mobile (24).

13. Le kit conformément à une quelconque des revendications précédentes, dans lequel ce dispositif indicateur (27) est une règle permettant de mesurer le mouvement relatif entre l'élément mobile (24) et le segment tubulaire dans lequel il est logé.

14. Le kit conformément à une quelconque des revendications précédentes, dans lequel la pluralité de segments tubulaires est un premier élément tubulaire (11) et un deuxième élément tubulaire (12) ;

15. Le kit conformément à une quelconque des revendications précédentes, dans lequel chaque soutien (1) comprend également une ou plusieurs des particularités suivantes :

- les segments tubulaires sont cylindriques ;
- cet élément de connexion (22) est intégré dans l'élément fileté (20) ;
- aucun élément du soutien extensible (1) ne dépasse le plan défini par le périmètre extérieur des segments tubulaires ;
- au moins un troisième élément tubulaire (13) pourvu d'un couplage fileté est couplé à une portion intermédiaire de l'élément fileté (20), non inséré dans aucun des segments tubulaires, et en ce que cet au moins troisième élément tubulaire (13) se déplace dans le sens longitudinal de l'élément fileté (20) au moyen de l'opération causée par la rotation filetée du troisième élément tubulaire (13) ;
- l'élément tubulaire (2) du soutien possède des trous traversants transversaux ;
- ce limiteur d'insertion maximale (23) est une portion centrale aménagée entre l'élément de connexion (20) et l'élément fileté (22), le limiteur d'insertion maximale (23) ayant une coupe extérieure plus grande que la cavité intérieure des éléments tubulaires à connecter.

5

10

15

20

25

30

35

40

45

50

55

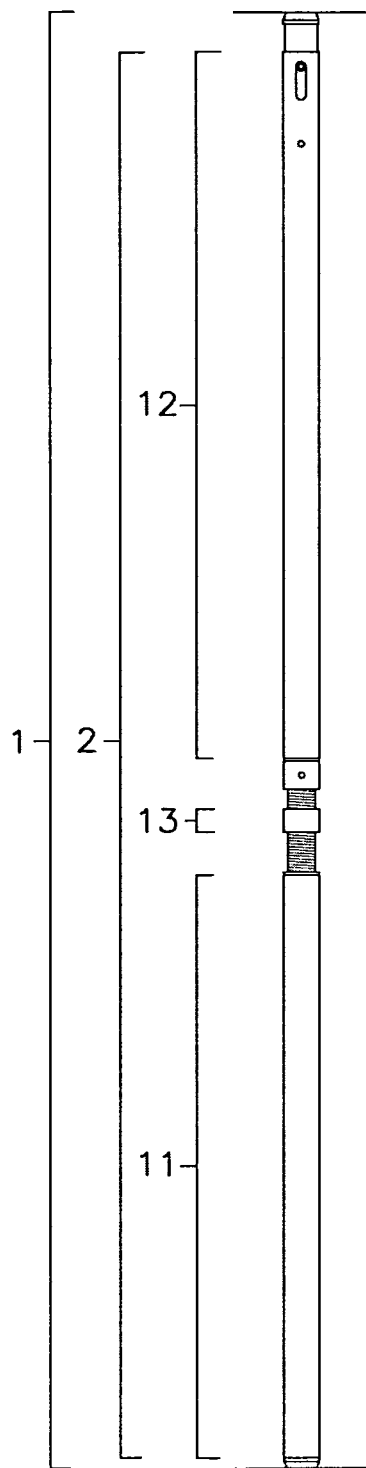

Fig. 1

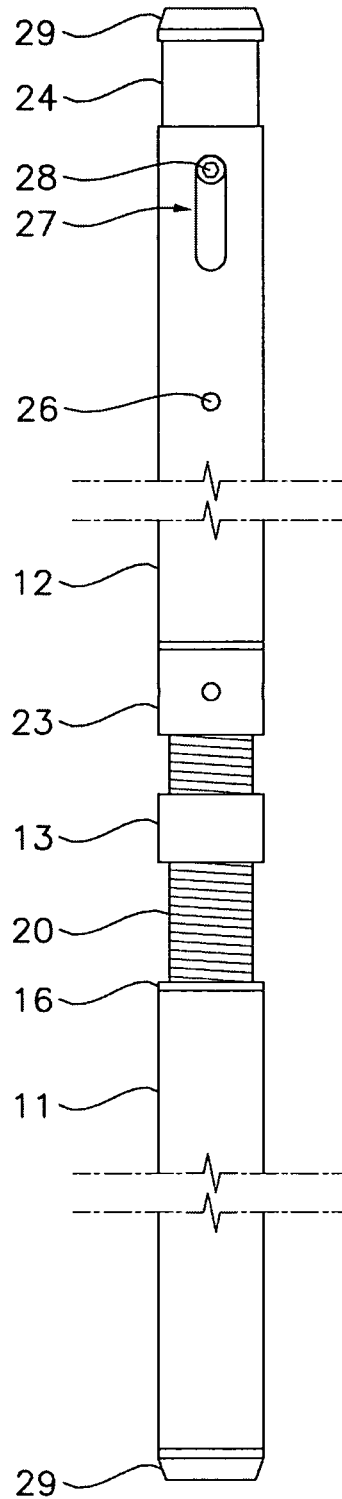

Fig. 2

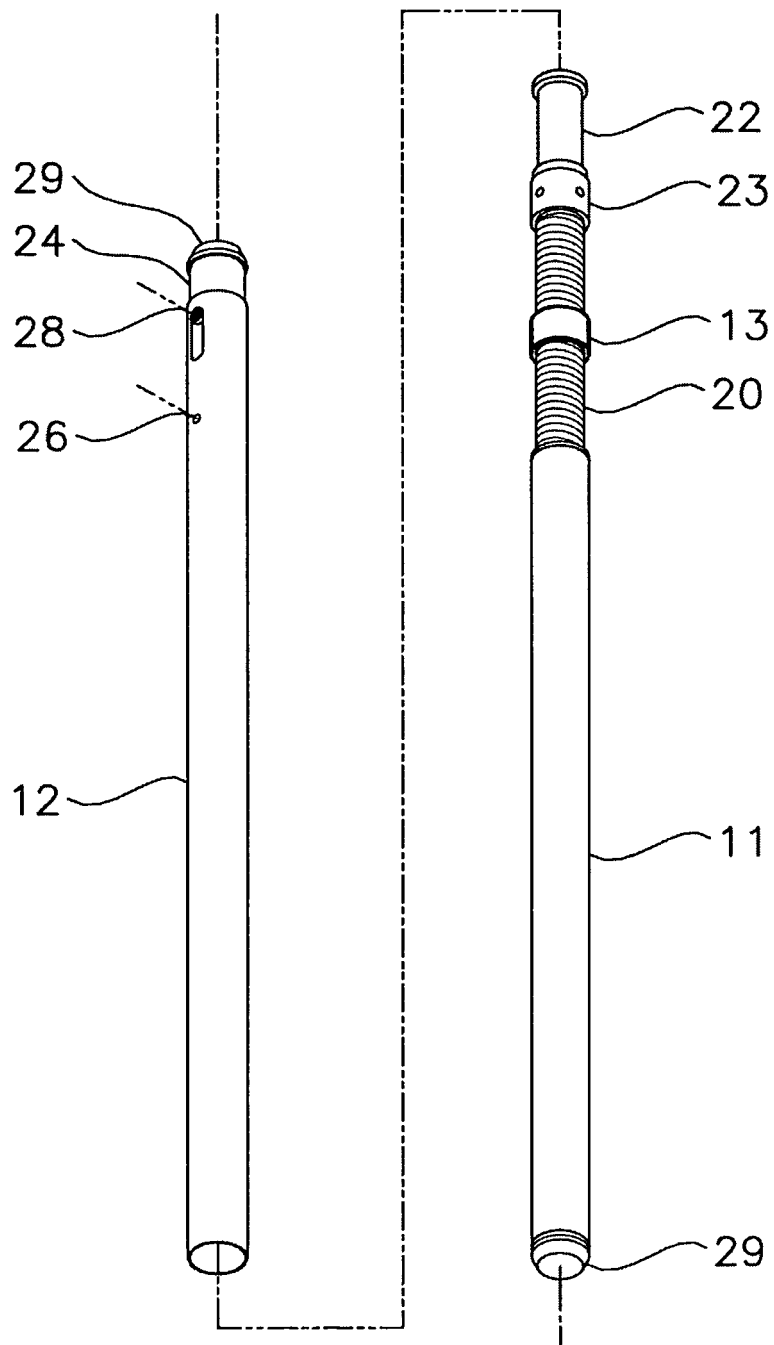

Fig.3a

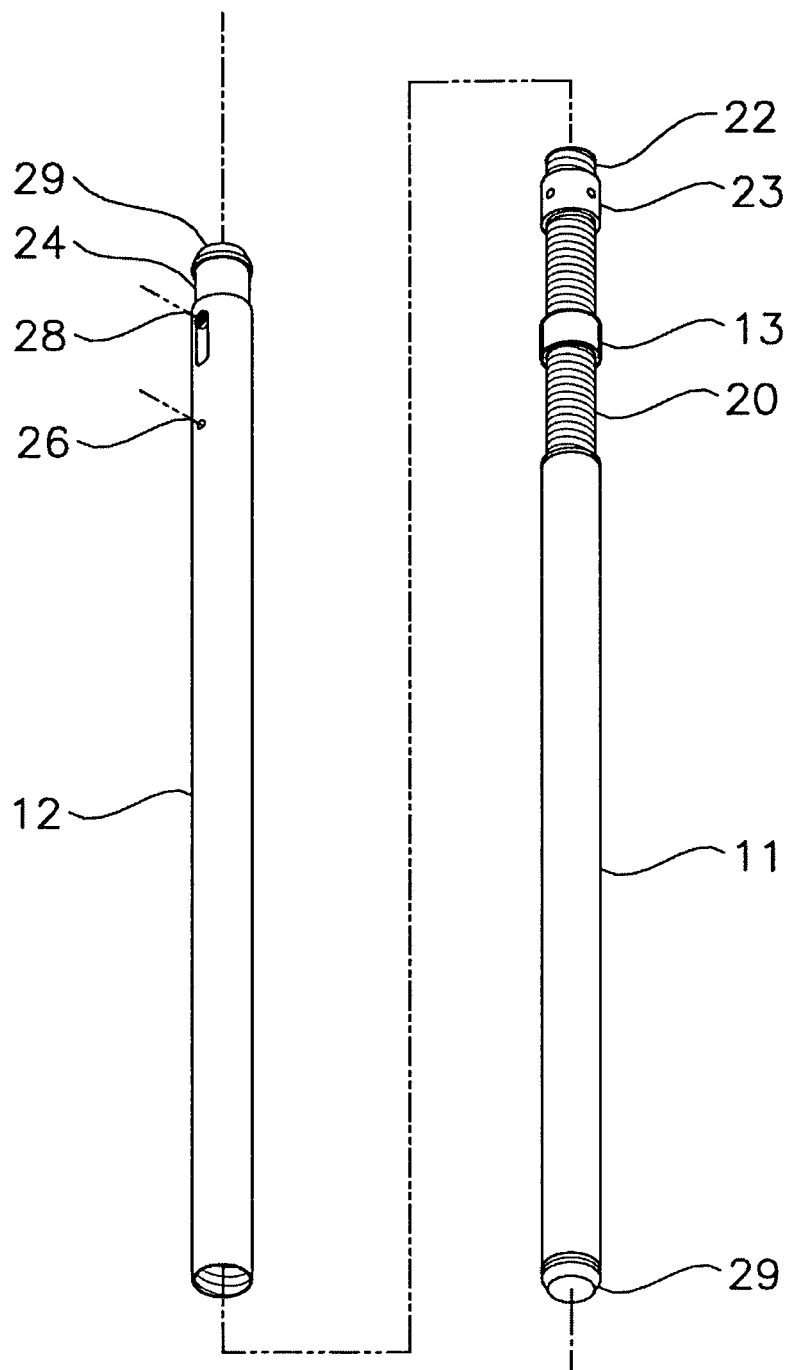
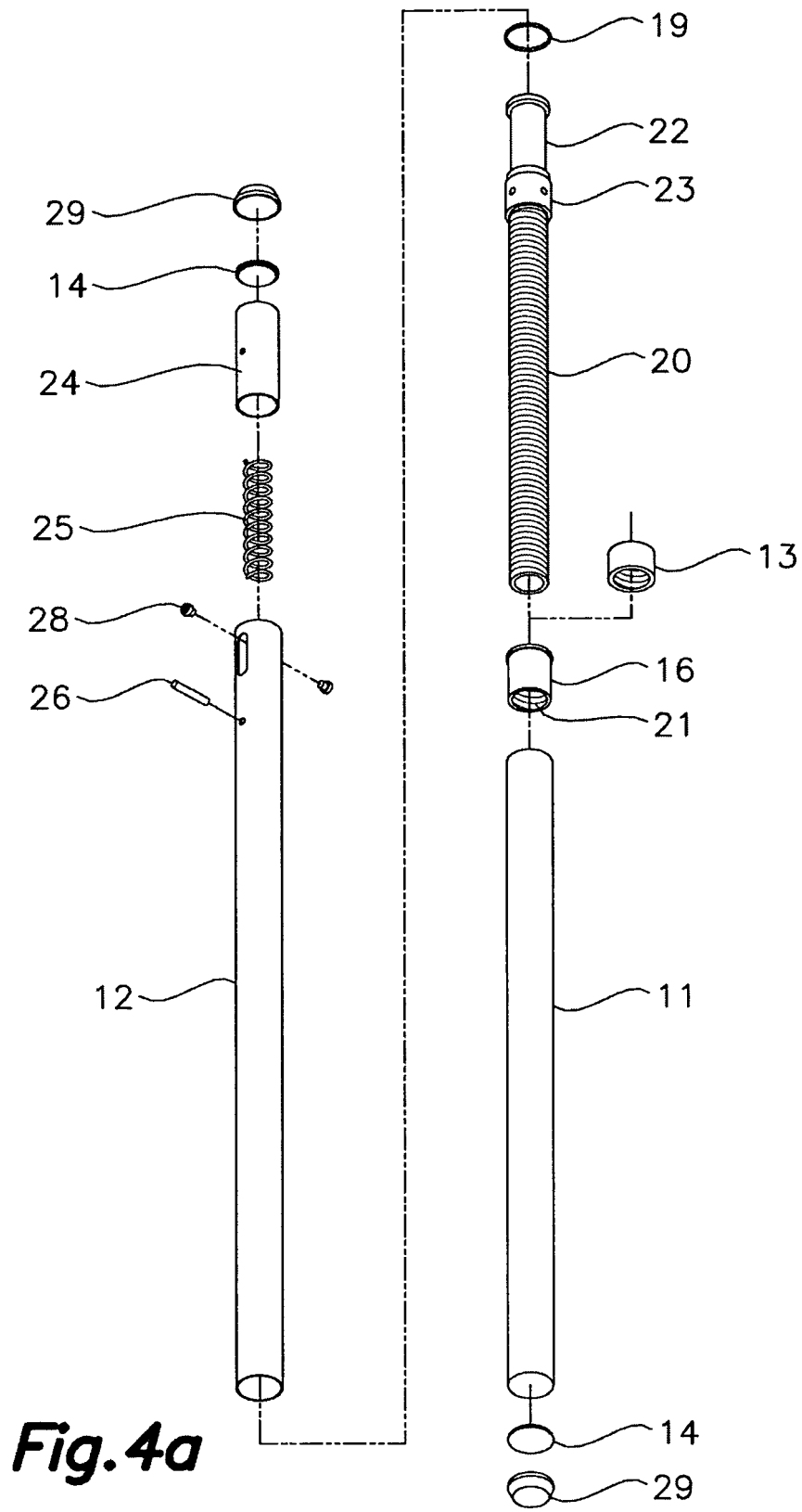
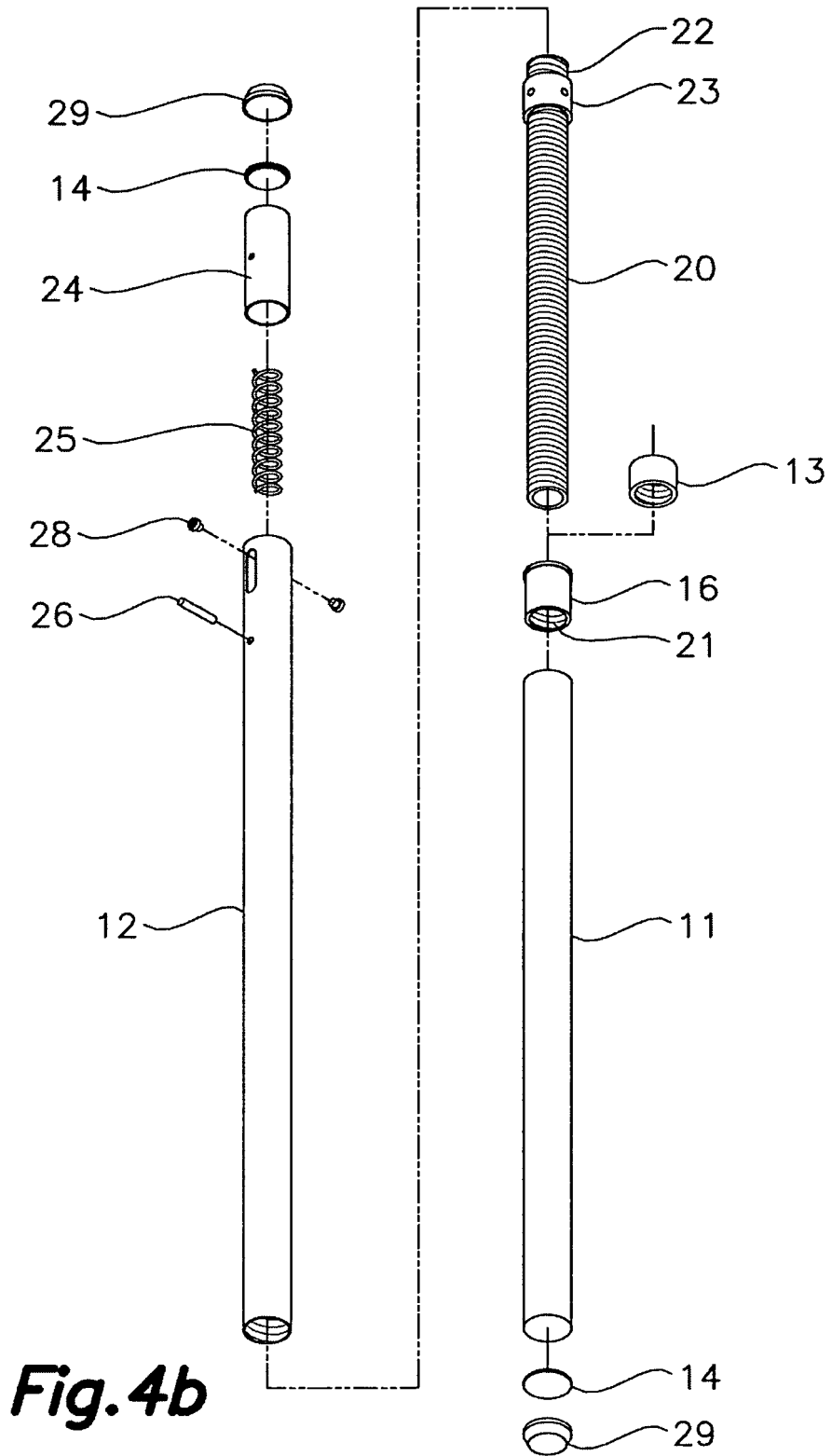

Fig. 3b





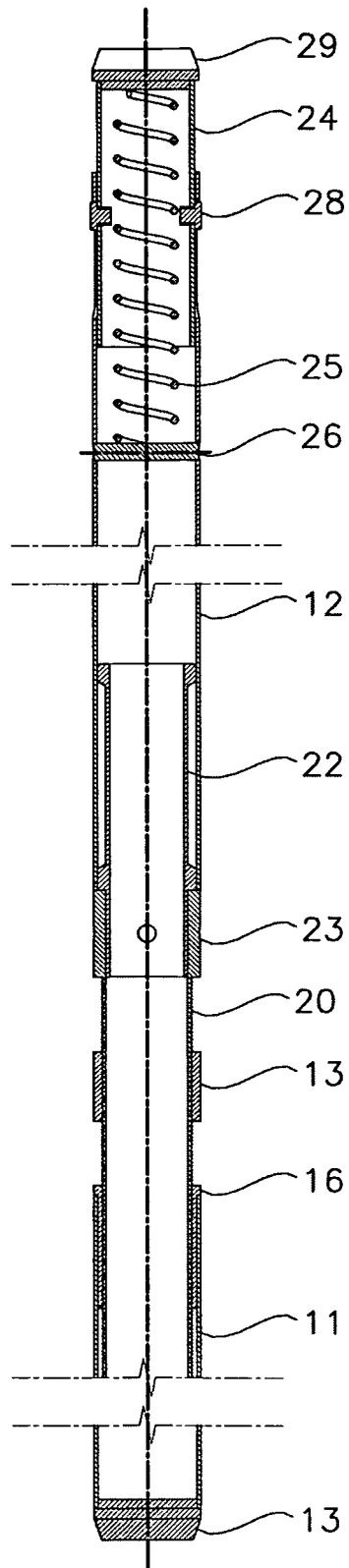

Fig.5

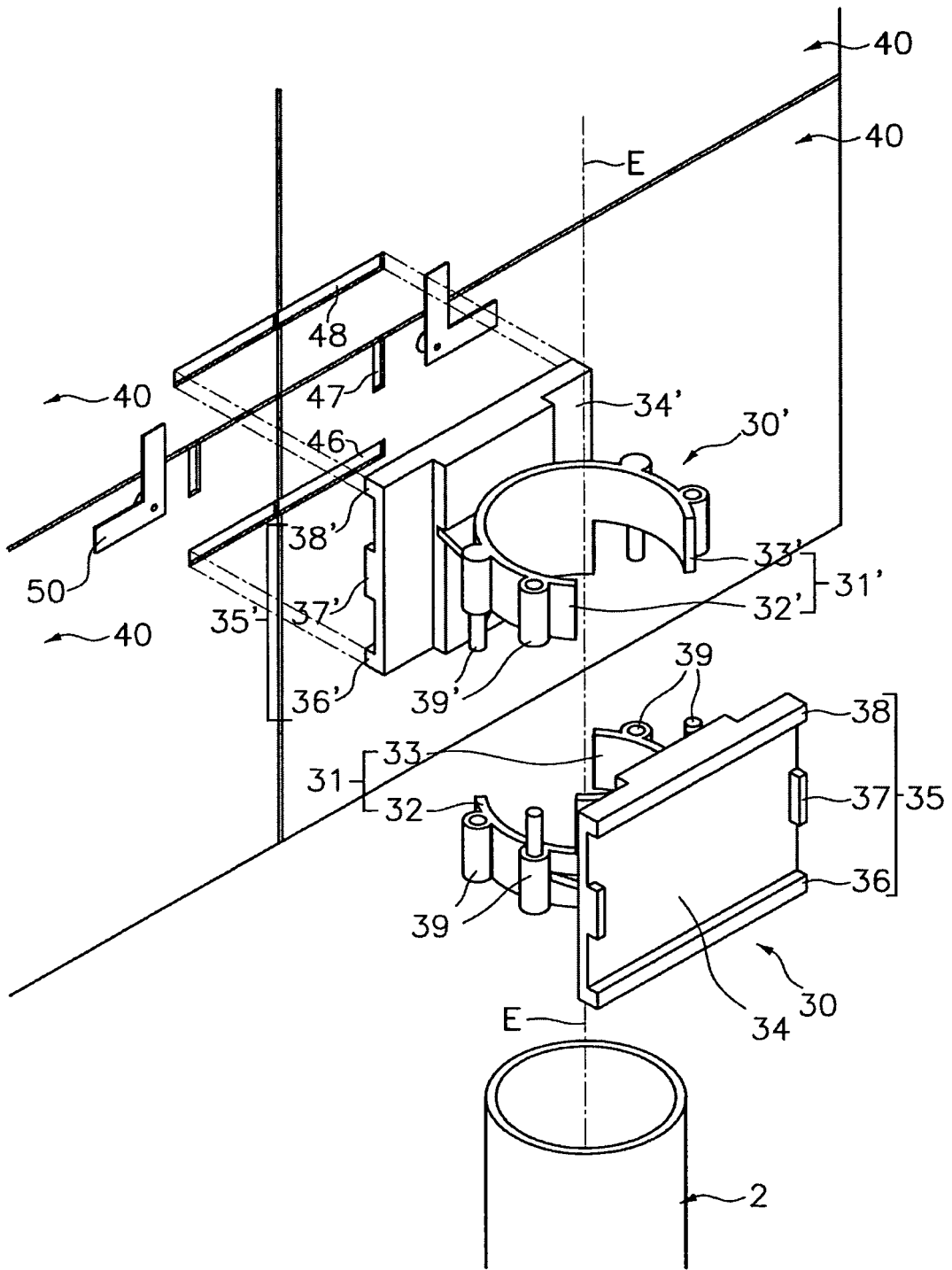

Fig. 6

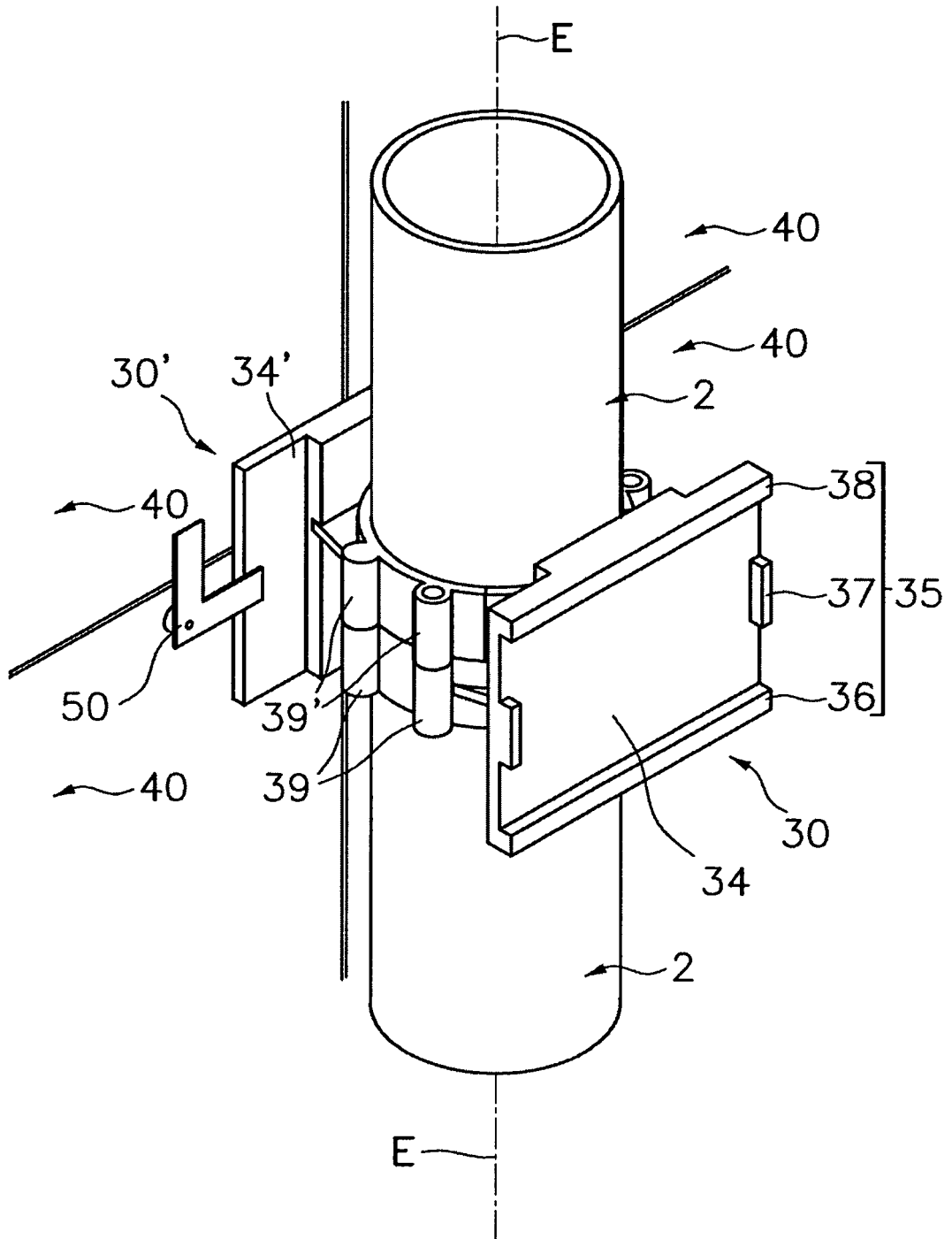

Fig. 7

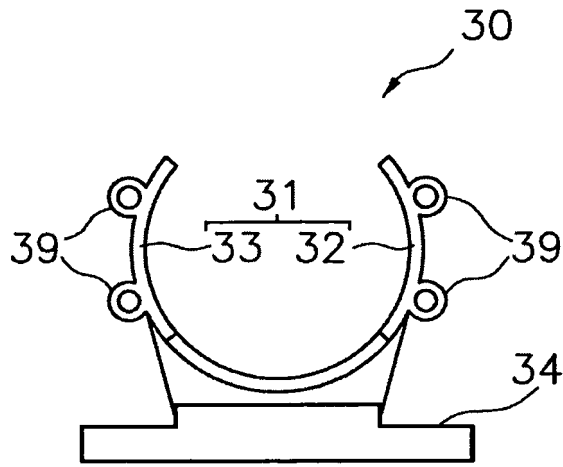

Fig. 8

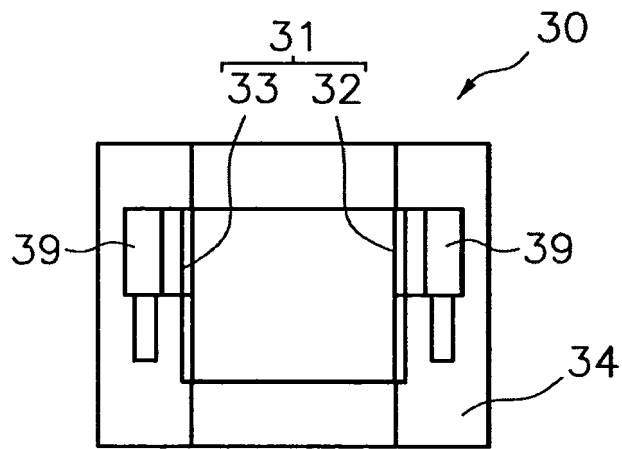

Fig. 9

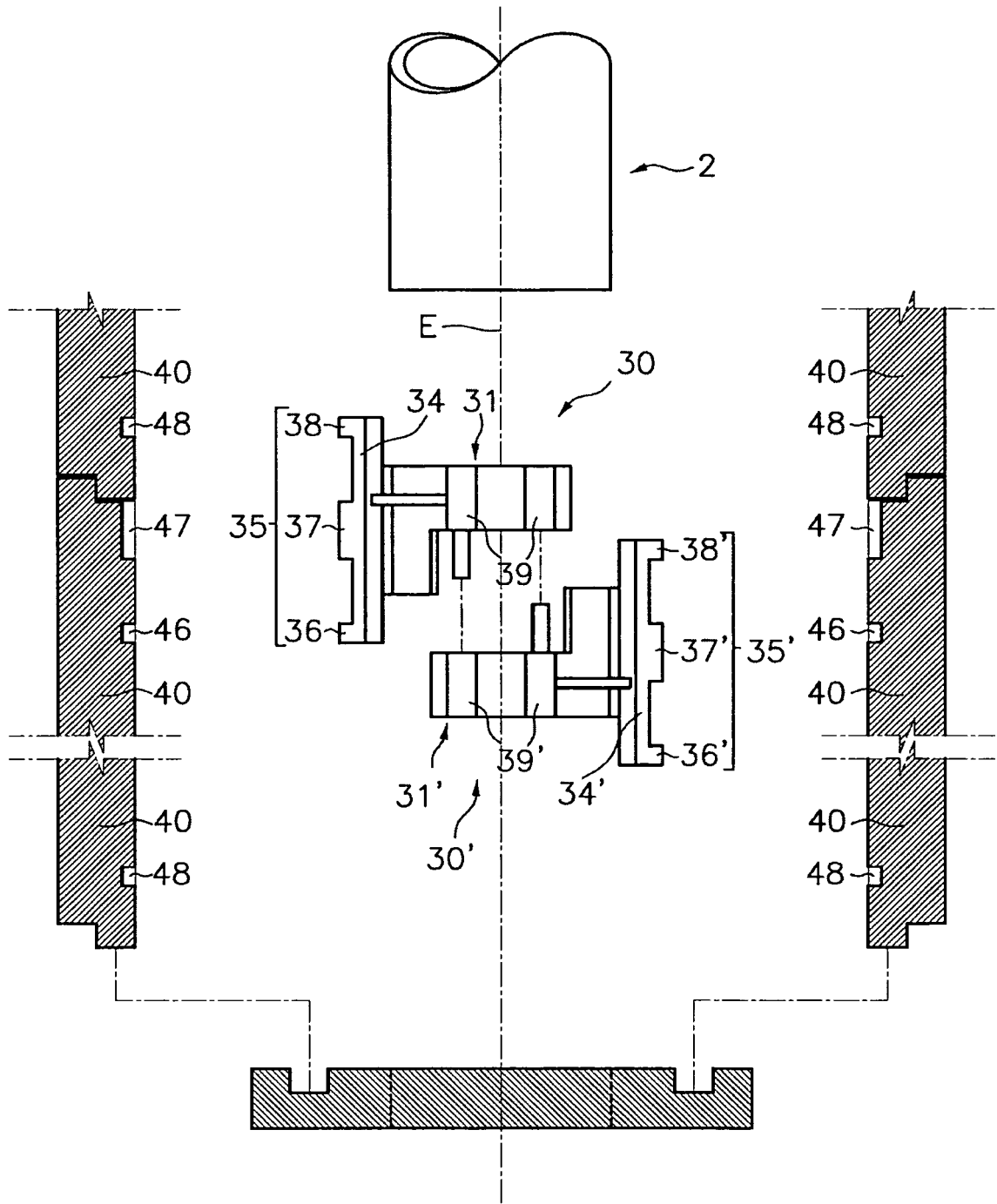

Fig. 10

REFERENCES CITED IN THE DESCRIPTION

This list of references cited by the applicant is for the reader's convenience only. It does not form part of the European patent document. Even though great care has been taken in compiling the references, errors or omissions cannot be excluded and the EPO disclaims all liability in this regard.

Patent documents cited in the description

- DE 202004016792 U [0003] [0009]
- GB 695937 A [0004]
- US 4449876 A [0005]
- DE 202006005611 [0007]
- FR 2936827 [0008]
- ES 1117832 U [0010]
- EP 1850045 A [0011]
- DE 29500415 U [0012]
- CA 2739414 [0012]
- US 2855037 A [0012]