



**FOR THE PURPOSES OF INFORMATION ONLY**

Codes used to identify States party to the PCT on the front pages of pamphlets publishing international applications under the PCT.

<b>AL</b>	Albania	<b>ES</b>	Spain	<b>LS</b>	Lesotho	<b>SI</b>	Slovenia
<b>AM</b>	Armenia	<b>FI</b>	Finland	<b>LT</b>	Lithuania	<b>SK</b>	Slovakia
<b>AT</b>	Austria	<b>FR</b>	France	<b>LU</b>	Luxembourg	<b>SN</b>	Senegal
<b>AU</b>	Australia	<b>GA</b>	Gabon	<b>LV</b>	Latvia	<b>SZ</b>	Swaziland
<b>AZ</b>	Azerbaijan	<b>GB</b>	United Kingdom	<b>MC</b>	Monaco	<b>TD</b>	Chad
<b>BA</b>	Bosnia and Herzegovina	<b>GE</b>	Georgia	<b>MD</b>	Republic of Moldova	<b>TG</b>	Togo
<b>BB</b>	Barbados	<b>GH</b>	Ghana	<b>MG</b>	Madagascar	<b>TJ</b>	Tajikistan
<b>BE</b>	Belgium	<b>GN</b>	Guinea	<b>MK</b>	The former Yugoslav Republic of Macedonia	<b>TM</b>	Turkmenistan
<b>BF</b>	Burkina Faso	<b>GR</b>	Greece			<b>TR</b>	Turkey
<b>BG</b>	Bulgaria	<b>HU</b>	Hungary	<b>ML</b>	Mali	<b>TT</b>	Trinidad and Tobago
<b>BJ</b>	Benin	<b>IE</b>	Ireland	<b>MN</b>	Mongolia	<b>UA</b>	Ukraine
<b>BR</b>	Brazil	<b>IL</b>	Israel	<b>MR</b>	Mauritania	<b>UG</b>	Uganda
<b>BY</b>	Belarus	<b>IS</b>	Iceland	<b>MW</b>	Malawi	<b>US</b>	United States of America
<b>CA</b>	Canada	<b>IT</b>	Italy	<b>MX</b>	Mexico	<b>UZ</b>	Uzbekistan
<b>CF</b>	Central African Republic	<b>JP</b>	Japan	<b>NE</b>	Niger	<b>VN</b>	Viet Nam
<b>CG</b>	Congo	<b>KE</b>	Kenya	<b>NL</b>	Netherlands	<b>YU</b>	Yugoslavia
<b>CH</b>	Switzerland	<b>KG</b>	Kyrgyzstan	<b>NO</b>	Norway	<b>ZW</b>	Zimbabwe
<b>CI</b>	Côte d'Ivoire	<b>KP</b>	Democratic People's Republic of Korea	<b>NZ</b>	New Zealand		
<b>CM</b>	Cameroon	<b>KR</b>	Republic of Korea	<b>PL</b>	Poland		
<b>CN</b>	China	<b>KZ</b>	Kazakstan	<b>PT</b>	Portugal		
<b>CU</b>	Cuba	<b>LC</b>	Saint Lucia	<b>RO</b>	Romania		
<b>CZ</b>	Czech Republic	<b>LI</b>	Liechtenstein	<b>RU</b>	Russian Federation		
<b>DE</b>	Germany	<b>LK</b>	Sri Lanka	<b>SD</b>	Sudan		
<b>DK</b>	Denmark	<b>LR</b>	Liberia	<b>SE</b>	Sweden		
<b>EE</b>	Estonia			<b>SG</b>	Singapore		

**METHODS AND APPARATUS FOR PREVENTING  
MIGRATION OF SUTURES THROUGH TRANSOSSEOUS TUNNELS**

Background of the Invention

5

This application is a continuation-in-part of U.S. Application Serial No. 08/163,130, filed December 6, 1993, which is a continuation-in-part of U.S. application serial number 07/765,445, filed September 25, 1991, and issued as U.S. Patent 5,268,001, which is a continuation-in-part of U.S. patent application serial  
10 number 07/588,055, filed September 25, 1990, now abandoned. The entire contents of these applications are incorporated herein by reference.

15

This invention pertains to surgical systems and, more particularly, methods and apparatus for attaching tissue to bone. The invention has application in, for example, rotator cuff repair.

20

It is not uncommon for tendons and other soft tissues to tear or to detach from bone. Athletes, for example, often suffer "rotator cuff" tears, in which the supraspinatus tendon separates from the humerus, causing pain and loss of ability to  
20 elevate and externally rotate the arm. Complete separation can occur if the shoulder is subjected to gross trauma. Typically, however, the tear begins as a small lesion, especially, in older patients.

25

To repair a torn rotator cuff, surgeons must reattached the supraspinatus tendon to the humerus. Traditionally, this has been done by boring several holes obliquely through the greater tuberosity, that is, the bony structure on the outer side of the head of the humerus. Sutures are then passed through these holes, or transosseous tunnels, in order to secure the tendon.

30

Though use of such sutures to anchor the tendon have been referred to as the "gold standard," it has been shown that the sutures migrate through the bone itself, particularly, along the upper edge of the openings that define the ends of transosseous tunnels on lateral cortex of the greater tuberosity. This is particularly pronounced in older patients, whose bone structures tend to be weaker and,

therefore, less resistant to degradation under the force of the sutures. On prior art solution has been to augment the edges of the transosseous tunnels by affixing plate-like pieces; *see*, Gerber *et al*, "Mechanical Strength of Repairs of the Rotator Cuff," Journal of Bone Joint Surgery, v. 76, n. 3, p. 371 - 380 (May 1994). See  
5 France *et al*, "Biomechanical Evaluation of Rotator Cuff Fixation Methods," The American Journal of Sports Medicine, v. 17, n. 2, pp. 176 *et seq.*

Drawbacks of plate-like augmentation of the greater tuberosity are the difficulties in positioning and affixing the plates. Though endoscopic surgery is  
10 generally preferred, use of augmentation plates necessitates that rotator cuff repair be performed by open surgery. Moreover, the plates must be affixed to the bone by surgical glues in order to avoid risk that they will migrate from the site in the event of suture breakage.

15 An object of this invention is to provide improved surgical systems and, more particularly, methods and apparatus for attaching tissue to bone.

Another object of this invention is to provide improved methods and  
20 apparatus for rotator cuff repair.

A related object of the invention is to provide improved methods for reinforcing the edges of transosseous tunnels against force of sutures.

#### Summary of the Invention

25 The above objects are among those met by the invention, which provides in one aspect an improvement on a method for attaching soft tissue to bone by passing a suture through an opening in the bone, e.g., a transosseous tunnel, and affixing the soft tissue with the suture. The improvement, for preventing the suture  
30 from migrating through the bone at the end of the opening, includes placing a eyelet into an end of the bone opening and passing the suture through the eyelet, as well as through the opening in the bone, in order to affix the soft tissue with the

suture.

In a related aspect, the invention provides a method as described above for use in attaching the spinatus tendon to the humerus bone by placing an eyelet into an end of a transosseous tunnel and passing the suture through the eyelet, as well as through the tunnel, in order to affix the tendon to the humerus.

Further aspects of the invention provides methods as described above, in which the eyelet is screwed, or fit by interference, into the bone opening. In still further related aspects, the bone opening is expanded prior to placement of the eyelet.

In another aspect, the invention provides an apparatus for use in rotator cuff repair for reinforcing a transosseous tunnel to prevent migration of a suture through bone at the end of the tunnel. The apparatus comprises an eyelet arranged for placement within the end of the tunnel, or within an expanded hole formed at the end of the tunnel. The eyelet has a channel therethrough for passage of the suture and can include a flanged head to prevent the eyelet from being forced too far into the tunnel.

Related aspects of the invention provide an apparatus as described above in which the eyelet is threaded for screwing into bone on the inside of the wall of the hole or, alternatively, is arranged for interference fit with that inside wall.

Still another aspect of the invention provides an improvement on a method for attaching soft tissue to bone by passing a suture through an opening in the bone and affixing the soft tissue with the suture. The improvement, for reinforcing the bone opening, includes placing an expandable member into an end of the bone opening and inserting an insertion element into a channel that passes through the expandable member. A portion of the insertion element has an outer diameter greater than an inner diameter of at least a portion of the channel in the expandable member, so that insertion of the insertion element into the expandable member

causes the expandable member to expand to obtain a pressure fit with the bone opening. The improvement further includes passing the suture through an channel of the insertion element, as well as through the opening in the bone, in order to affix the soft tissue with the suture.

5

Another aspect of the invention provides a method as described above in which the expandable member is substantially cylindrical and has an axial channel that extends between its proximal and distal ends. According to this embodiment, the insertion element is likewise elongate and has an axial channel extending  
10 between its proximal and distal ends.

10

In yet another aspect, the methods described above are adapted for rotator cuff repair. Accordingly, the step of placing the expandable member into the end of the bone opening comprises placing that member into the end of a transosseous  
15 tunnel in the humerus.

15

Yet another aspect of the invention provides methods as described above in which an emplacement element is used to place an expandable member into the end of the bone opening. In a related aspects, the emplacement element is frangibly  
20 attached to the expandable member such that application of force to the insertion element breaks the frangible attachment between those elements after that force has caused the insertion element to expand the expandable member.

20

Advantages of the invention include the ability to install the reinforcing  
25 eyelet via endoscopic surgery, as well as open surgery.

25

These and other aspects of the invention are evident in the drawings and in the description that follows.

#### Brief Description of the Drawings

30

A more complete understanding of the invention may be attained by reference to the drawings, in which:

Figure 1A depicts a partially torn rotator cuff;

Figure 1B depicts the rotator cuff of Figure 1A repaired in accord with prior art surgical techniques;

5

Figure 2 depicts a surgical rotator cuff repaired according to the invention;

Figure 3A - 3E depict an eyelet according to the invention and its use in rotator cuff repair according to the invention; and

10

Figures 4 - 7 depict further eyelets according to the invention.

#### Detailed Description of the Illustrated Embodiment

15

Figure 1A depicts a partially torn rotator cuff. In the illustration, the globular head 10 of humerus 12 rests in the glenoid cavity 14 formed by the scapula 16. The supraspinatus muscle 18 traverses the scapular spine (not shown) and converges into a tendon 19 (undifferentiated in the illustration), then end of which is normally fully inserted into a facet of the greater tuberosity 22. A partial tear rotator cuff tear results when a portion 24 of the tendon 19 detaches from the greater tuberosity 22, as shown in the illustration

20

Figure 1B illustrates the rotator cuff of Figure 1A repaired in accord with the prior art suturing technique, in which the tendon 19 is resecured to the humerus by a suture 26 passed through a transosseous tunnel 28 bored obliquely through the greater tuberosity 22. A further understanding of the prior art suturing technique may be attained by reference to Gerber, *et al*, "Mechanical Strength of Repairs of the Rotator Cuff," Journal of Bone and Joint Surgery, v. 76-B, no. 3 (May 1994), at pp. 371, *et seq.*, the teachings of which are incorporated herein by reference.

25  
30

Though Figure 1B shows use of only a single transosseous tunnel and suture, multiple tunnels and sutures are typically used, as discussed in the

aforementioned prior art reference. Each suture can be looped superiorly (i.e., over the greater tuberosity), passed through the tendon and tied to itself. Alternatively, pairs of adjacent sutures can be tied together between the exit holes on the lateral cortex.

5

Figure 2 illustrates a modified suturing technique according to the invention. The modification comprises use of a bone "eyelet" 32 to reinforce the opening 30 at the end of transosseous tunnel 28 on the lateral cortex of the greater tuberosity 22. This prevents migration of the suture 26 through the upper edge of the opening 30. Such migration has been discovered to result from repeated loading of the suture during use of the shoulder.

10

The eyelet 32 comprises a cylinder, or other such solid geometric shape (e.g., parallelepiped), suitable to be embedded into the humerus 12 and, particularly, the greater tuberosity 22, as shown. The eyelet 32 includes a cannula 34, which is aligned with the transosseous tunnel 28, through which suture 26 passes. The eyelet 32 also preferably includes a head 36 that protrudes above the bone surface. This head 36 is flanged to prevent the eyelet 32 from being driven too far into the opening 30 and, more particularly, to prevent the head from being driven below the bone surface on emplacement or as a result of forces exerted by the suture 26.

15

20

The eyelet 32 is threaded into transosseous tunnel 28 or is held by interference fit, surgical epoxy or, simply, by the force exerted by suture 26. In instances where the eyelet 32 requires it, the end 30 of the tunnel 28 can be enlarged to facilitate embedding the eyelet in the bone.

25

The eyelet 32 is comprised of a biocompatible material, i.e., a material that is chemically and biologically inert, such as, an implant grade high density polyethylene, low density polyethylene (PE 6010 and PE 2030) and polypropylene (13R9A and 23M2: all made by Rexene, Dallas, Texas). The eyelet 32 may also be comprised of a metal, such as, surgical implant grade stainless steel.

30



In one preferred embodiment, an eyelet 40 according to the invention is constructed in a manner similar to the bone anchor of the type described in copending, commonly assigned U.S. Application Patent Application Serial No. 08/163,130, filed December 6, 1993, the teachings of which are incorporated herein  
5 by reference. Such an eyelet is illustrated in Figures 3A - 3E.

Referring to Figure 3A, the eyelet 40 generally comprises an elongated insertion element 42 and an approximately cylindrical expandable member 44. In its unexpanded state, the expandable member 44 can be placed into a bone hole 45,  
10 i.e., the end 30 of the transosseous tunnel 28 or an enlarged opening drilled into the bone at the end 30 of the tunnel 28. The expandable member 44 includes an axial channel 46, running end to end, for receiving the insertion element and for permitting passage of a transosseous suture.

As shown in the drawing, the outer diameter of at least a portion of the insertion element 42 is greater than the inner diameter of at least a portion of the axial channel 46 of the expandable member 44. Accordingly, when the insertion element 42 is inserted into the axial channel 46, the wider portion of the insertion element 42 exerts on the walls of the expandable member 44 a force orthogonal to  
15 the channel 46. This outward force causes the expandable member 44 to expand against the walls of bone hole 45, fixing the insertion element 42 within the expandable member 44 and fixing the expandable member 44 in a pressure fit firmly within the opening 45.  
20

The expandable member 44 includes an outer surface for secured engagement with an inner surface of the transosseous tunnel. That outer surface can be smooth or can be provided with a plurality of ridges 48, as shown. In particular, a preferred configuration includes a plurality of annular ridges for engaging irregularities in the bone opening wall as the expandable member 44  
25 deforms and conforms to the bone opening wall during and after expansion.  
30

The expandable member 44 also includes a flanged head 49 disposed at the

end to prevent the member 44 from being driven too far into the transosseous tunnel on emplacement or as a result of forces exerted by the transosseous suture. The head 49 preferably has a rounded outer surface to better distribute loads placed on it by the suture.

5

The insertion element 42 is a substantially elongated shape with an outer surface having one or more projections 50 for engagement with the inner surface of the axial channel 46 of expandable member 44. The projections 50 include portions with outer diameters that are greater than the inner diameter of the channel 46, as shown, so that they expand the expandable member 44 upon insertion.

10

The insertion element 42 includes a channel 52 running the length of the element, from end to end. The channel is sized to permit passage of a suture 26 of the type used for transosseous suture repair of the rotator cuff.

15

The eyelet 40 is embedded in the transosseous tunnel 28 45 using an emplacement device of the type disclosed in aforementioned U.S. Application Patent Application Serial No. 08/163,130. The device includes a cylindrical holding member 54 that holds the expandable member during emplacement via a frangible junction 55. The holding member also retains the insertion element 42 in alignment with the end of the expandable member 44, as shown. The emplacement device further includes a plunger 56 that exerts force on the insertion element 42 forcing it into the frangibly-retained expandable member 44 and causing the holding member to break-away from the expandable member 44, once insertion is complete.

20

25

A further understanding of the construction and operation of a bone anchor upon which the eyelet 40 is based may be attached by reference to aforementioned U.S. Application Patent Application Serial No. 08/163,130, the teachings of which are incorporated herein by reference.

30

A surgical technique according to the invention proceeds in accord with

conventional surgical techniques for suture rotator cuff repair. Once the transosseous tunnel 28 is drilled, however, the eyelet 40 is installed in order to reinforce the bone hole 45 and, particularly, the opening 30 at the end of transosseous tunnel 28 on the lateral cortex of the greater tuberosity 22.

5 Particularly, as shown in Figure 3A, the eyelet 40 is positioned in the end of the bone hole 45. As shown in Figures 3B, the plunger 56 is used to force the insertion element 42 into the expandable member 44, thereby fixing the insertion element 42 within the expandable member 44 and fixing the expandable member 44 in a pressure fit firmly within the opening 45. As shown in Figure 3C, once the

10 insertion element 42 is fully inserted, the continued force of the plunger 56 causes the holding member 54 to detach from the expandable member 44 at the frangible junction 55. Once the eyelet is installed, the suture rotator cuff repair surgery is completed in the normal course, with the transosseous suture 26 being passed through the eyelet 40 and, particularly, channels 46 and 52, as shown in Figure 4D.

15 The completed repair, using eyelet 40, is shown in Figure 3E.

Eyelets other than that shown in Figures 3A - 3E may also be used to practice the invention. These are shown, for example, in Figures 4 - 7.

20 Referring to Figures 4A - 4C, there is shown a threaded two-part eyelet 58 having an insertion member 60 and an expandable member 62. The eyelet is used in the manner described above, however, the insertion member 60 is screwed (rather than pushed) into the expander member 62 after the latter has been placed in the bone hole. As shown in Figures 4B and 4C, as the insertion element

25 advances into the expander member, camming surfaces 63 on the insertion element 60 force wings 64 on the expander member 62 into walls of the bone hole. The expanded wings act as anchors, preventing the assembled unit (as shown in Figure 4C) from moving within the hole. The expander element includes a flanged head region that prevents the assembly from being driving further into the bone hole by

30 the force of the suture (not shown). As above, both the insertion member 60 and expander element 62 are cannulated in order to permit the suture to pass therethrough.

Figures 5A - 5D show one-piece eyelets 70 according to the invention. Referring to Figures 5A and 5C, each eyelet 70 includes a head 72 to prevent the eyelet from being driven too far into the bone hole. The eyelet 70 also includes a cannula 74 to permit passage of a suture. On the exterior surface of the body of the eyelet are one or more annular wings that anchor the eyelet within the bone hole. An embodiment with multiple such wings 76 is shown, in cross-section, in Figure 5A and, in side view, in Figure 5B. An embodiment with a single such wing 76 is shown, in cross-section in Figure 5C and, in side view, in Figure 5D. The wings 76 are flexed or compressed inwardly on insertion of the eyelet 70 into the bone hole. Once inserted in the bone hole, the resiliency of the wings forces them back to the expanded state whence they anchor the eyelet 70.

Figure 6 shows another one-piece eyelet 80 according to the invention. The eyelet 80 includes head 82, body 84 and cannula 85. The head 82 is flanged to prevent the eyelet 80 from being pushed too far into the bone hole 86 by suture 88. The cannula 85 permits passage of the suture 88 through the eyelet. Unlike eyelet 70 described above, eyelet 80 does not include wings at its distal end. Rather eyelet 80 is held by simple interference fit with the curved walls of hole 86, as shown.

Figure 7 shows yet another one-piece eyelet 90 constructed like eyelet 80, except for inclusion of spiral threads 92 on the body of the eyelet. These threads permit eyelet 90 to be screwed into bone hole 94, as shown.

The eyelets shown in Figure 4 - 7 are comprised of a biocompatible materials such as implant grade high density polyethylene, low density polyethylene (PE 6010 and PE 2030) and polypropylene (13R9A and 23M2: all made by Rexene, Dallas, Texas). The eyelets may also be comprised of a metal, such as, surgical implant grade stainless steel.

Described above are methods and apparatus meeting the objects set forth above. Those skilled in the art will appreciate that the illustrated embodiments are

shown and described by way of example only, and that other methods and apparatus incorporating modifications therein fall within the scope of the invention. For example, in addition to rotator cuff repair, the invention can be beneficially applied in connection with other soft tissue-to-bone attachments utilizing

5 transosseous tunnels, such as (by way of nonlimiting example) distal biceps tendon repair, scapho-lunate ligament repair and dorsal capsulodesis, DRUJ arthroplasty, reconstruction RCL/UCL of the thumb, reconstruction RCL/UCL of the fingers, repair of central siip for Boutonniere deformity of the hand, repair of terminal tendon for Mailet deformity of the hand, repair of avulsed or lacerated FDP/FDS,

10 repair of ATF/CF ligaments to correct lateral ligamentous instability of the ankle/foot, achilles tendon repair following tear, bifurcate ligament repair to correct avulsion of anterior lateral calcaneous. In view of the foregoing, what we claim is:

1           1.       In a method for attaching soft tissue to bone by passing a suture  
2 through a transosseous tunnel in the bone and affixing the soft tissue with the  
3 suture, the improvement for reinforcing an opening at the end of the tunnel,  
4 comprising the steps of

5

6           A.       placing an eyelet into the end of the tunnel, the eyelet having an  
7 channel extending therethrough;

8

9           B.       passing the suture through the channel of the eyelet, as well as  
10 through the transosseous tunnel, in order to affix the soft tissue to  
11 the bone with the suture.

12

13           2.       In a method for rotator cuff repair by attaching the spinatus tendon  
14 to the humerus by passing a suture through a transosseous tunnel in the bone and  
15 affixing the soft tissue with the suture, the improvement for reinforcing the tunnel,  
16 comprising the steps of

17

18           A.       placing an eyelet into an end of the tunnel, the eyelet having an  
19 channel extending therethrough;

20

21           B.       passing the suture through the channel of the eyelet, as well as  
22 through the transosseous tunnel, in order to affix the soft tissue to  
23 the bone with the suture.

24

25           3.       In a method according to any of claims 1 and 2, the further  
26 improvement comprising screwing the eyelet into bone at the end of the tunnel.

27

28           4.       In a method according to any of claims 1 and 2, the further  
29 improvement comprising affixing the eyelet into bone at the end of the tunnel by  
30 interference fit.

31

32           5.       In a method according claim 2, the further improvement comprising  
expanding an opening at the end of the tunnel prior to placing the eyelet therein.

1           6.     A device for reinforcing a transosseous tunnel to prevent migration  
2 of a suture through bone at the end thereof, comprising an eyelet arranged for  
3 placement within any of (i) a bone hole forming the end of the tunnel, and (ii) an  
4 expansion of the bone hole forming the end of the tunnel, said eyelet having a  
5 channel extending therethrough for passage of the suture.

6

7           7.     A device for use in rotator cuff repair for reinforcing a transosseous  
8 tunnel to prevent migration of a suture through humerus bone at the end of the  
9 tunnel, the device comprising an eyelet arranged for placement within any of (i) a  
10 bone hole forming the end of the tunnel, and (ii) an expansion of the bone hole  
11 forming the end of the tunnel, said eyelet having a channel extending therethrough  
12 for passage of the suture.

13

14           8.     A device according to any of claims 6 and 7, wherein the body of  
15 the eyelet is threaded for screwing into bone wall on any of (i) an inside of the  
16 bone hole forming the end of the tunnel, and (ii) an expansion of the bone hole  
17 forming the end of the tunnel.

18

19           9.     A device according to any of claims 6 and 7, wherein the body of  
20 the eyelet is arranged for interference fit with the bone wall on any of (i) an inside  
21 of the bone hole forming the end of the tunnel, and (ii) an expansion of the bone  
22 hole forming the end of the tunnel.

23

24           10.    A device according to any of claims 6 and 7, wherein the eyelet  
25 includes a flanged head portion.

26

27           11.    A device according to any of claims 6 and 7, wherein the eyelet  
28 comprises

29

30           A.     an expandable member having an channel extending therethrough;  
31                 and

32

1           B.     an insertion element including an channel extending therethrough, at  
2                 least a portion of the insertion element including an outer diameter  
3                 greater than an inner diameter of the channel at least a portion of the  
4                 expandable member for expansion thereof upon engagement  
5                 therewith, whereby, inserting the insertion element into the  
6                 expandable member causes the expandable member to expand to  
7                 obtain a pressure fit with the bone opening.

8  
9           12.    In a method for attaching soft tissue to bone by passing a suture  
10           through an opening in the bone and affixing the soft tissue with the suture, the  
11           improvement for reinforcing the bone opening comprising

12  
13           A.    placing an expandable member into an end of the bone opening, the  
14                 expandable member having an channel extending therethrough;

15  
16           B.    inserting an insertion element into the channel of the expandable  
17                 member, the insertion element including an channel extending  
18                 therethrough, at least a portion of the insertion element including an  
19                 outer diameter greater than an inner diameter of the channel at least  
20                 a portion of the expandable member for expansion thereof upon  
21                 engagement therewith, whereby, inserting the insertion element into  
22                 the expandable member causes expandable member to expand to  
23                 obtain a pressure fit with the bone opening; and

24  
25           C.    passing the suture through the channel of the insertion element, as  
26                 well as through the opening in the bone, in order to affix the soft  
27                 tissue to the bone with the suture.

28  
29           13.    In a method for attaching soft tissue to bone by passing a suture  
30           through an opening in the bone and affixing the soft tissue with the suture, the  
31           improvement for reinforcing the bone opening comprising

32



- 1           A.     placing a substantially cylindrical expandable member into an end of  
2                   the bone opening, the expandable member having an axial channel  
3                   extending between its proximal and distal ends;  
4
- 5           B.     inserting an elongate insertion element into the channel of the  
6                   expandable member, the insertion element including an axial channel  
7                   extending between its proximal and distal ends, at least a portion of  
8                   the insertion element including an outer diameter greater than an  
9                   inner diameter of at least a portion of the axial channel of the  
10                  expandable member for expansion thereof upon engagement  
11                  therewith, whereby, inserting the insertion element into the  
12                  expandable member causes expandable member to be to expand to  
13                  obtain a pressure fit with the bone opening; and  
14
- 15          C.     passing the suture through the axial channel of the insertion element,  
16                   as well as through the opening in the bone, in order to affix the soft  
17                   tissue to the bone with the suture.

18

19           14.     In a method according to any of claims 12 and 13, wherein the  
20                  method is adapted for rotator cuff repair, the further improvement wherein the  
21                  placing step includes the step of placing the expandable member into an end of a  
22                  transosseous tunnel in the humerus.

23

24           15.     In a method according to any of claims 12 and 13, the further  
25                  improvement comprising using an emplacement element to place an expandable  
26                  member into the end of the bone opening.

27

28           16.     In a method according to claim 15, the further improvement wherein  
29                  the expandable member being frangibly attached to the emplacement element.

30

31           17.     In a method according to claim 16, the further improvement wherein  
32

1 the inserting step includes applying force to the insertion element, and

2

3 the method comprises breaking the frangible attachment between the  
4 expandable member and the emplacement element by applying force to the  
5 insertion element subsequent to expansion of the expandable member in the bone  
6 opening.

7

8 18. In a method according to claim 17, wherein the method is adapted  
9 for rotator cuff repair, the further improvement wherein the placing step includes  
10 the step of placing the expandable member into an end of a transosseous tunnel in  
11 the humerus.

12

13 19. In a method for attaching soft tissue to bone by passing a suture  
14 through an opening in the bone and affixing the soft tissue with the suture, the  
15 improvement for reinforcing the bone opening comprising

16

17 A. using an emplacement element to place an expandable member into  
18 an end of the bone opening, the expandable member having an  
19 channel extending therethrough, the expandable member being  
20 frangibly attached to the emplacement element;

21

22 B. applying a compressive force to said expandable member to expand  
23 its channel so that an outer surface of said expandable member  
24 engages with the bone; and

25

26 C. breaking the frangible attachment between the expandable member  
27 and the emplacement element, and removing the emplacement  
28 element; and

29

30 D. passing the suture through the axial channel of the insertion element,  
31 as well as through the opening in the bone, in order to affix the soft  
32 tissue to the bone with the suture.

1           20.    In a method according to claim 19, the further improvement  
2    comprising applying the compressive force to the expandable element by inserting  
3    into the channel thereof an insertion element including an outer diameter greater  
4    than an inner diameter of at least a portion of the channel of the expandable  
5    member for expansion thereof upon engagement therewith.

6

7           21.    In a method according to any of claims 19 and 20, wherein the  
8    method is adapted for rotator cuff repair, the further improvement wherein the  
9    emplacement element is used to place the expandable member into an end of a  
10   transosseous tunnel in the humerus.

11

FIG. 1A

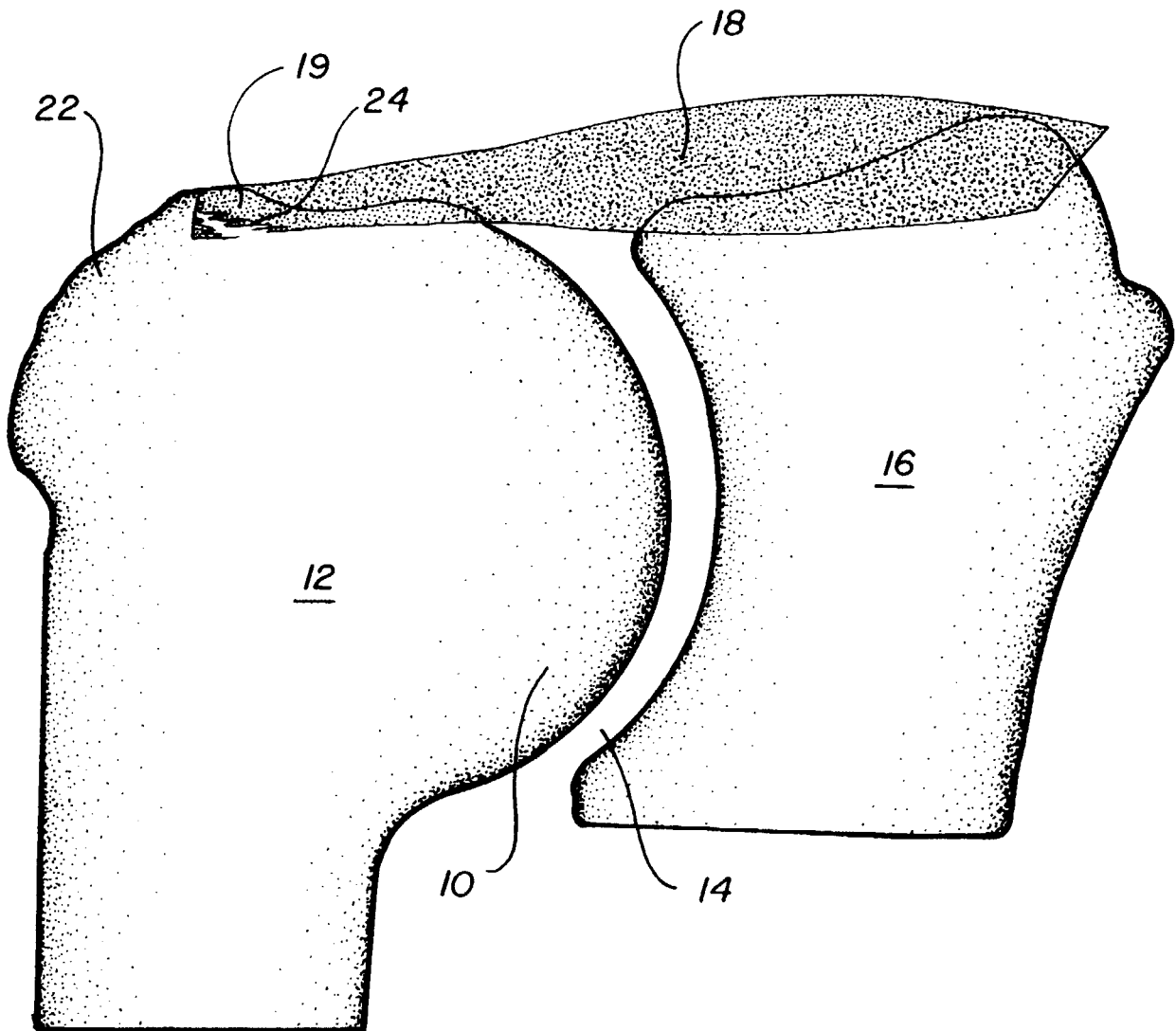

SUBSTITUTE SHEET (RULE 26)

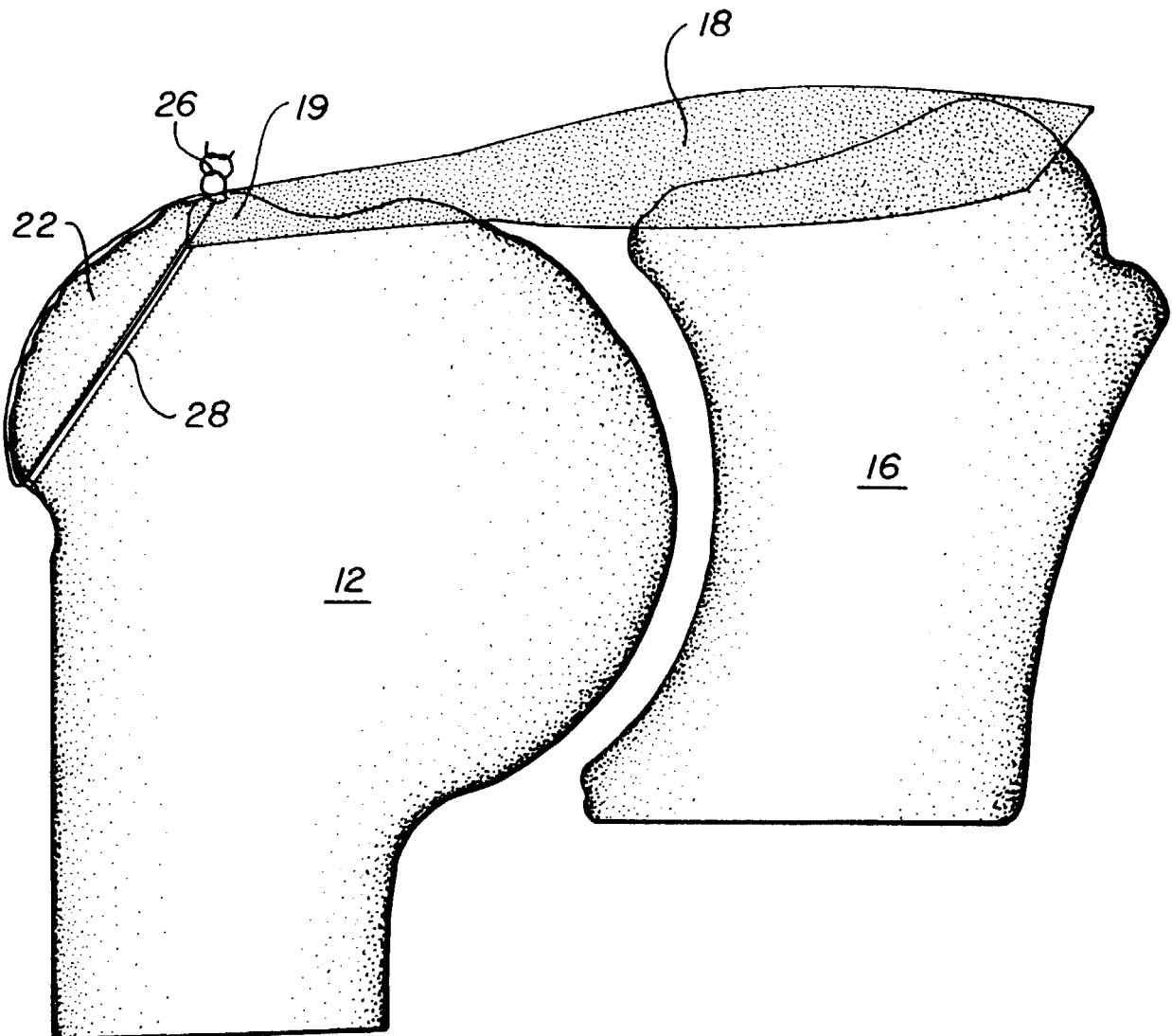
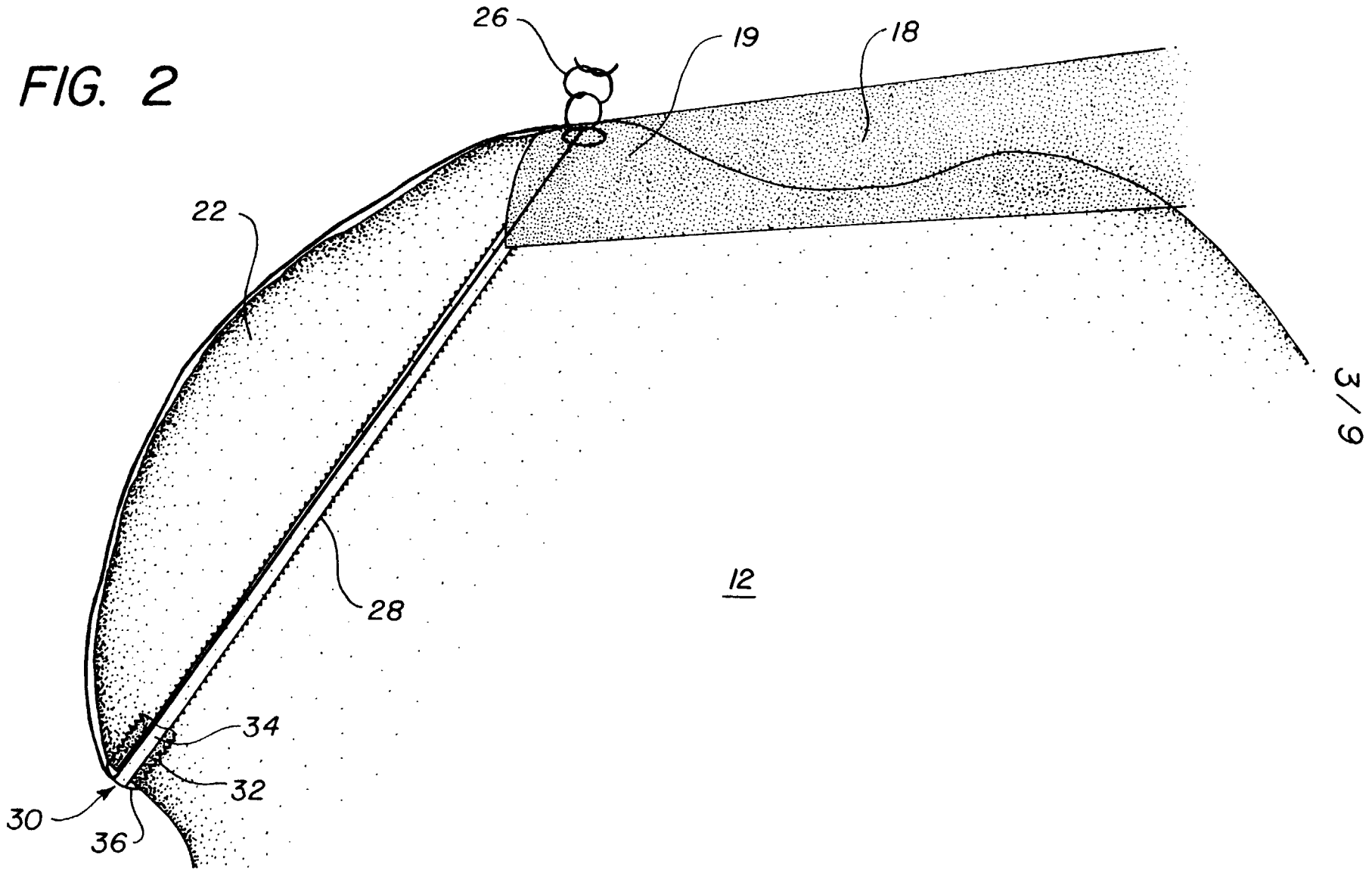

FIG. 2



SUBSTITUTE SHEET (RULE 26)

3 / 9

FIG. 3A

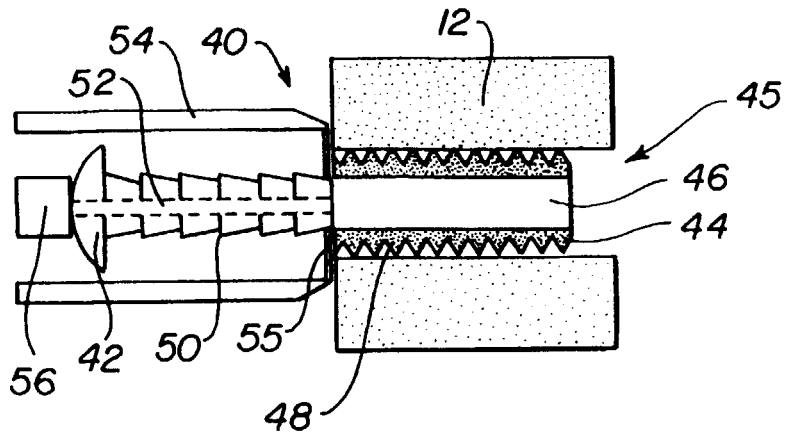

FIG. 3C

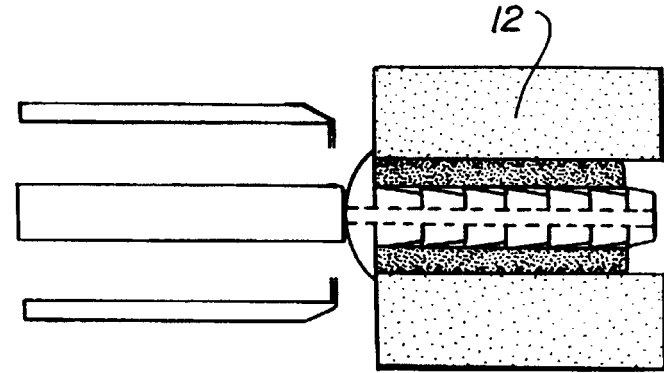

FIG. 3B

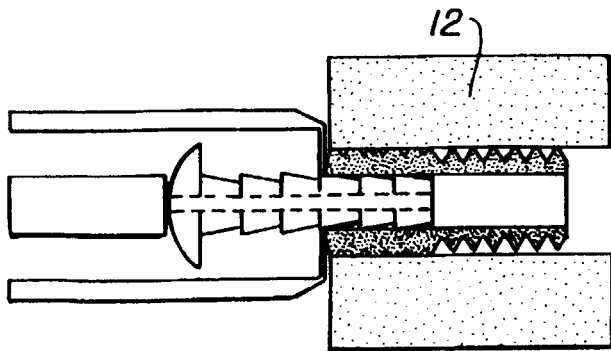

FIG. 3D

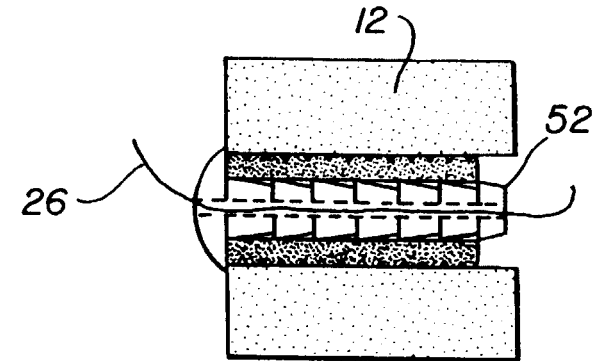

FIG. 3E

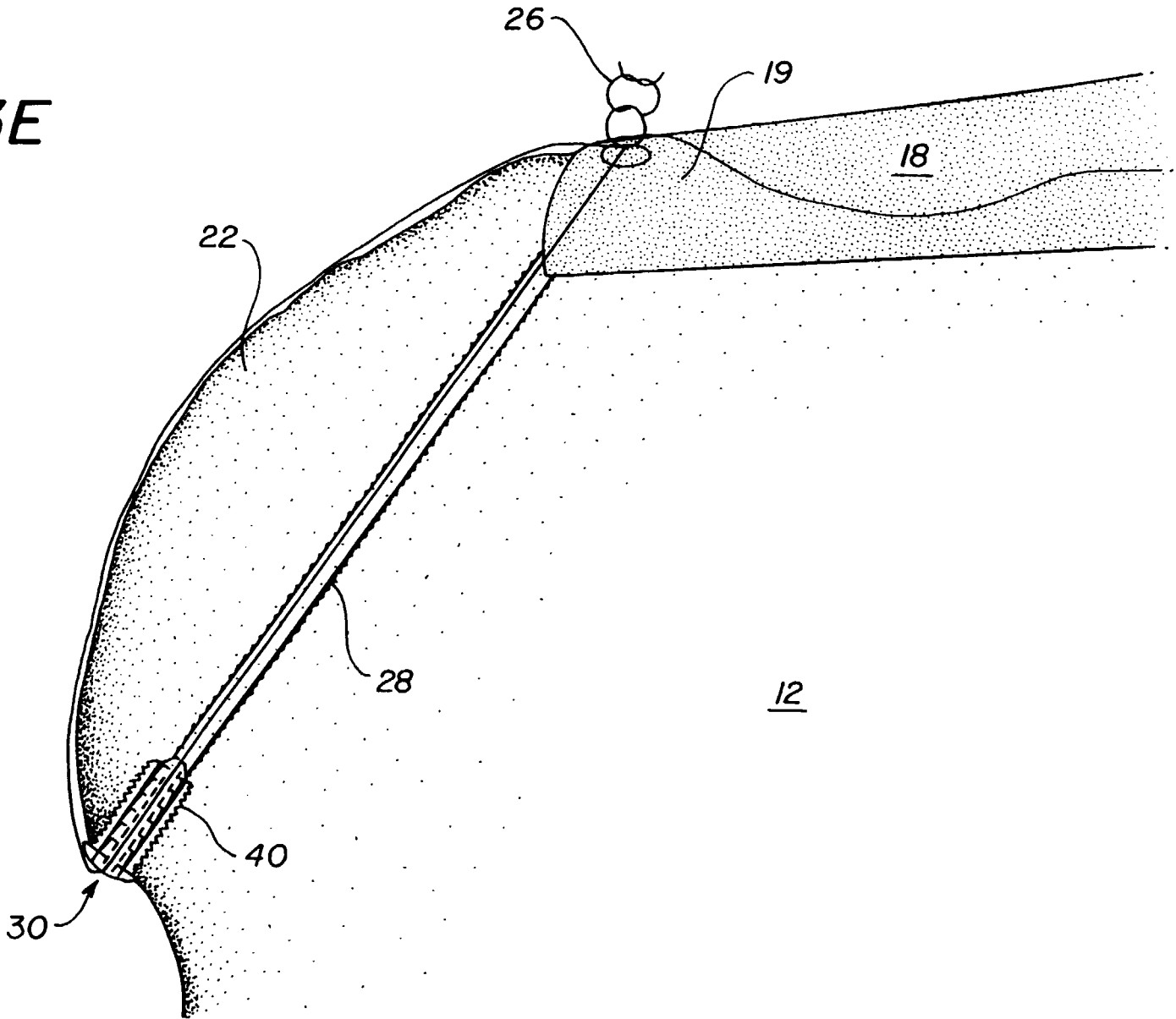



FIG. 4A

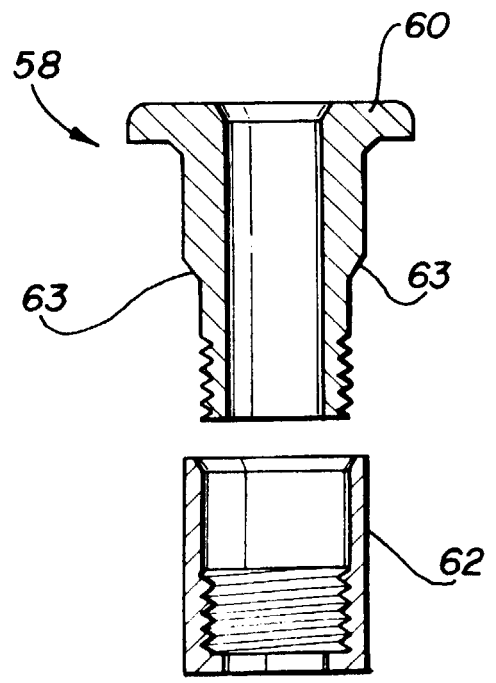

FIG. 4B

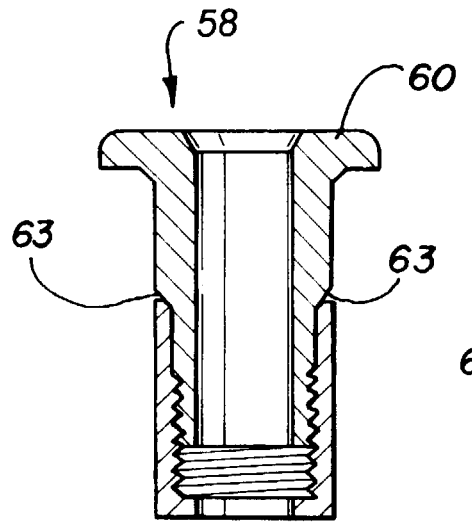
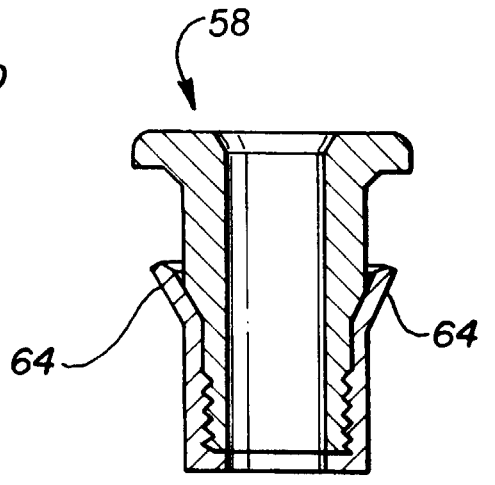
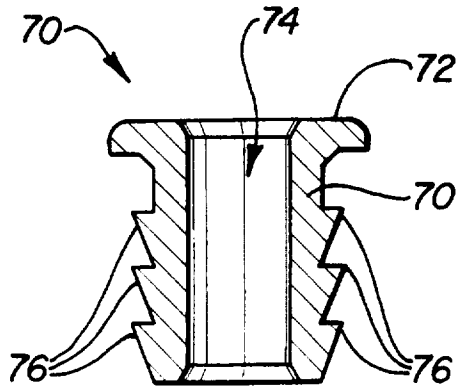

FIG. 4C



SUBSTITUTE SHEET (RULE 26)

**FIG. 5A**



**FIG. 5B**

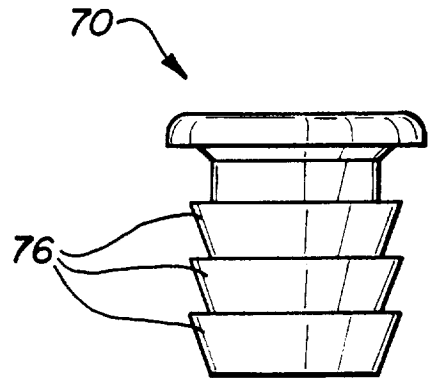

**FIG. 5C**

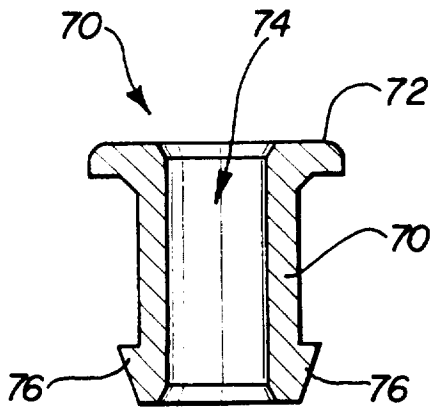

**FIG. 5D**

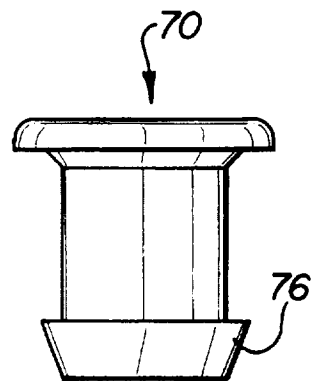

FIG. 6

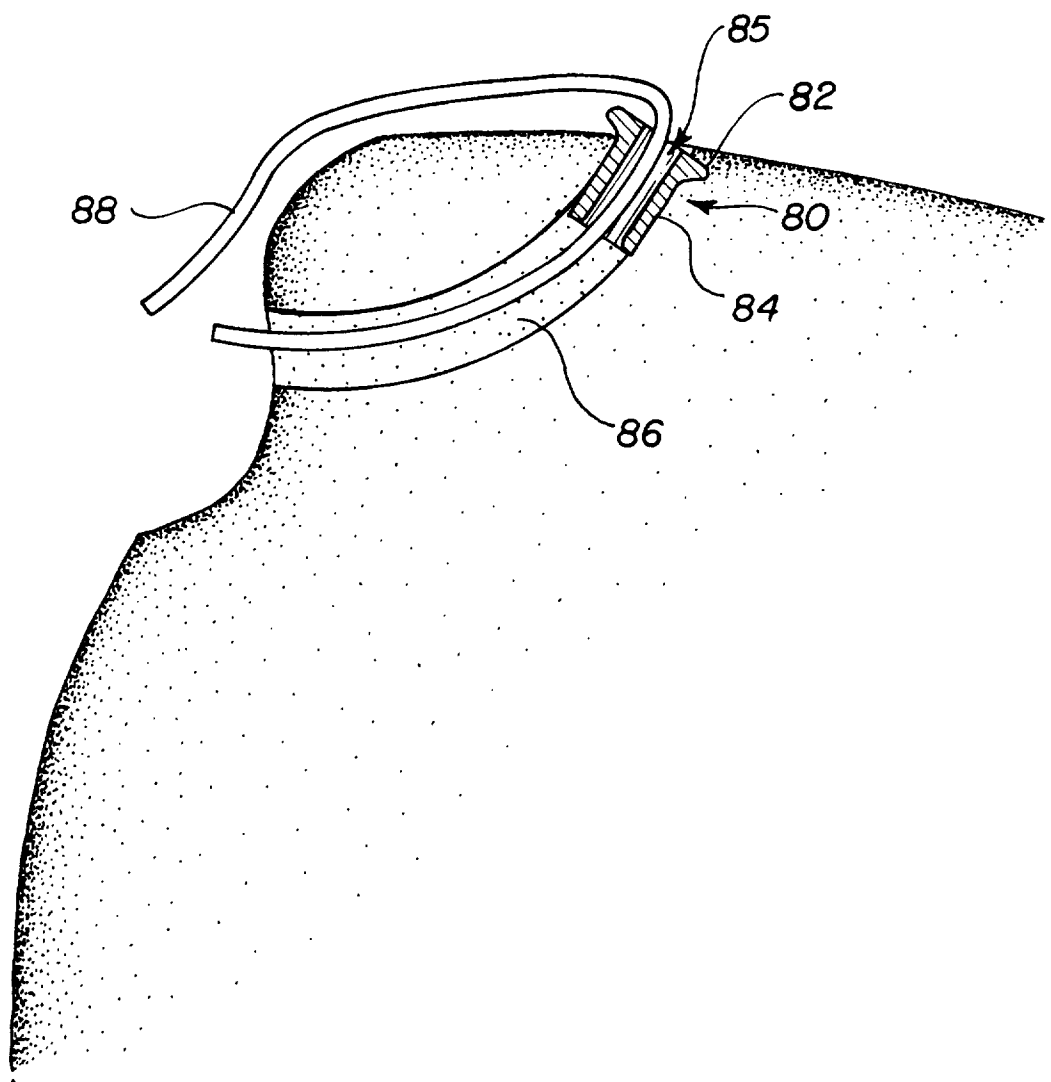
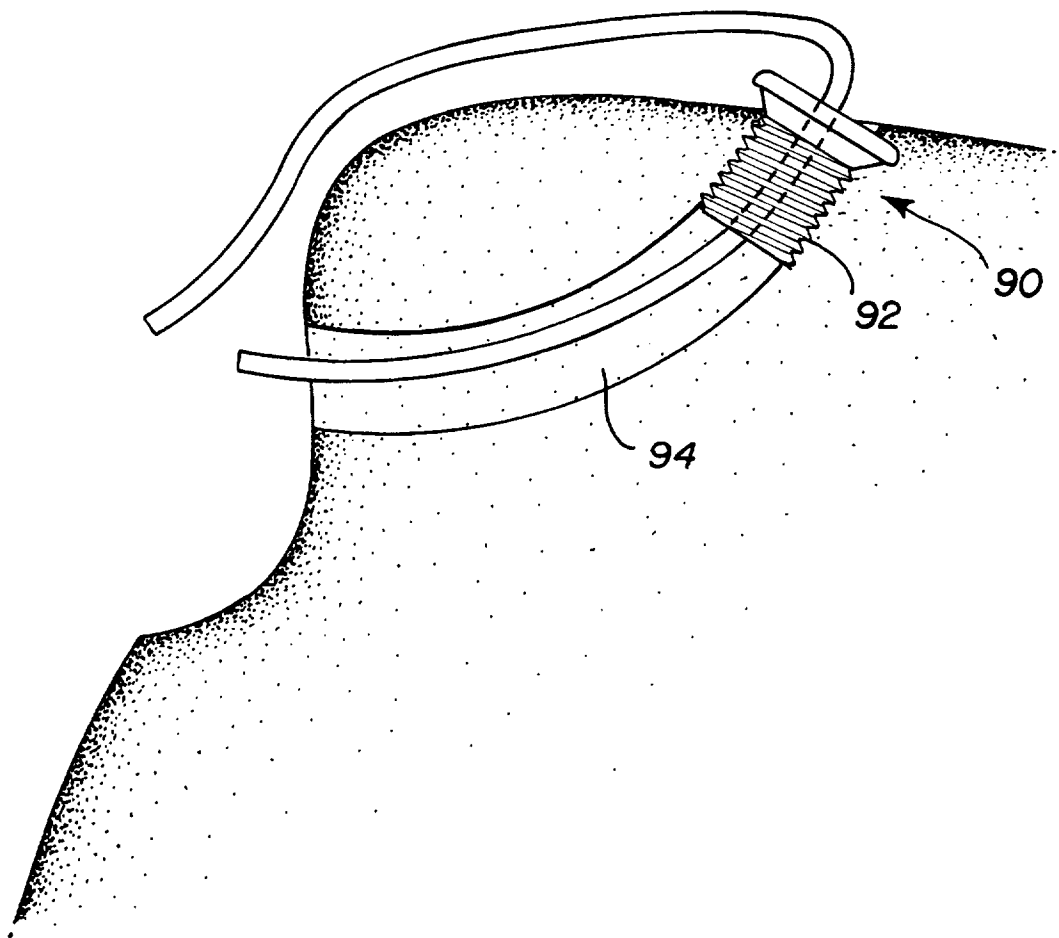

FIG. 7



INTERNATIONAL SEARCH REPORT

International application No.  
PCT/US97/14006

**A. CLASSIFICATION OF SUBJECT MATTER**

IPC(6) :A61B 17/56

US CL :606/72

According to International Patent Classification (IPC) or to both national classification and IPC

**B. FIELDS SEARCHED**

Minimum documentation searched (classification system followed by classification symbols)

U.S. : 606/72, 73, 86-88, 230-232

Documentation searched other than minimum documentation to the extent that such documents are included in the fields searched

Electronic data base consulted during the international search (name of data base and, where practicable, search terms used)

**C. DOCUMENTS CONSIDERED TO BE RELEVANT**

Category*	Citation of document, with indication, where appropriate, of the relevant passages	Relevant to claim No.
Y	US 4,738,255 A (GOBLE et al) 19 April 1988, entire document.	1-18
Y	US 4,632,100 A (SOMERS et al), 30 December 1986, entire document.	3, 8

Further documents are listed in the continuation of Box C.  See patent family annex.

- |       |   |     |  |
|-------|---|-----|--|
| * "A" | document defining the general state of the art which is not considered to be of particular relevance  | "T" | later document published after the international filing date or priority date and not in conflict with the application but cited to understand the principle or theory underlying the invention  |
| "B"   | earlier document published on or after the international filing date  | "X" | document of particular relevance; the claimed invention cannot be considered novel or cannot be considered to involve an inventive step when the document is taken alone   |
| "L"   | document which may throw doubts on priority claim(s) or which is cited to establish the publication date of another citation or other special reason (as specified) | "Y" | document of particular relevance; the claimed invention cannot be considered to involve an inventive step when the document is combined with one or more other such documents, such combination being obvious to a person skilled in the art |
| "O"   | document referring to an oral disclosure, use, exhibition or other means  | "G" | document member of the same patent family  |
| "P"   | document published prior to the international filing date but later than the priority date claimed  |     |  |

Date of the actual completion of the international search  
30 OCTOBER 1997

Date of mailing of the international search report  
17 NOV 1997

Name and mailing address of the ISA/US  
Commissioner of Patents and Trademarks  
Box PCT  
Washington, D.C. 20231

Authorized officer

MICHAEL A. BROWN

Facsimile No. (703) 305-3230

Telephone No. (703) 308-2682