

A. CHENU.
 Improvement in Centrifugal Machines.
 No. 131,081. Patented Sep. 3, 1872.

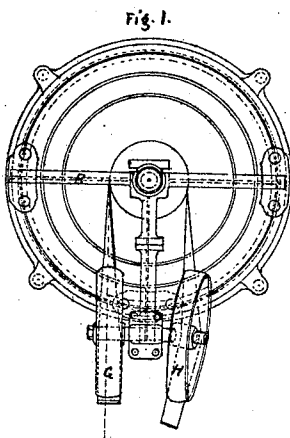
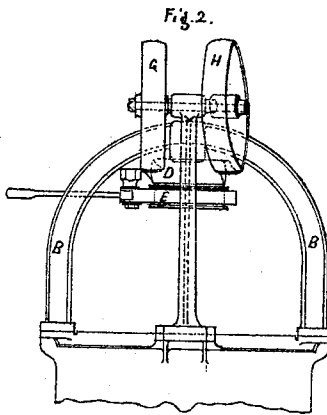
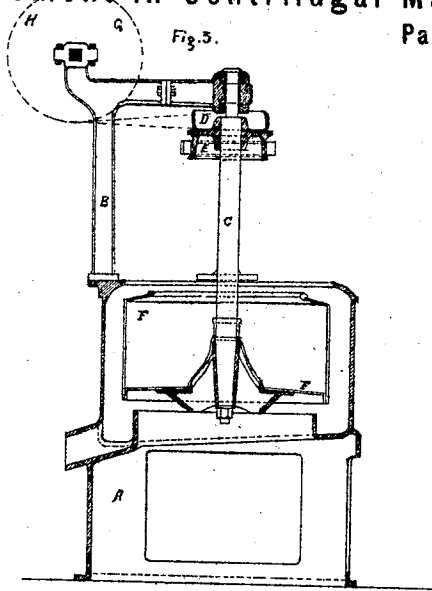

Witnesses,
 S. B. Hiddet
 L. H. Crutcher

Inventor,
 A. Chenu
 by his Attyys
 Crosby & Gould

UNITED STATES PATENT OFFICE.

ALPHONSE CHENU, OF PARIS, FRANCE.

IMPROVEMENT IN CENTRIFUGAL MACHINES.

Specification forming part of Letters Patent No. 131,081, dated September 3, 1872.

To all whom it may concern:

Be it known that I, ALPHONSE CHENU, director of the firm of Cail & Co., machine-builders, residing in Paris, 15 Quai de Grenelle, have invented certain new and useful Improvements in Centrifugal Machines; and I do hereby declare that the following is a full and exact description thereof, reference being made to the accompanying drawing.

My invention relates to certain improvements in the construction and arrangement of the Weston centrifugal machine, by means of which I am enabled to facilitate its erection, not only in new works, but also in existing works, to replace formerly-existing centrifugal machines.

The principal feature and essential arrangement for the erection of a Weston centrifugal consists in the suspension of the basket and its accessory parts to a separate framing by means of its vertical shaft, which rotates in a bearing in such a manner that the basket is free to oscillate in a lateral direction. The casing, instead of forming the solid foundation to the rotary apparatus with which it is solidary, like in most other centrifugals, is merely, in the Weston machine, a light and independent shell resting on the flooring, and serving merely to collect the liquids projected from the drum, and to evacuate the same by a lateral orifice, while on the other hand the drum itself is provided with a central valve corresponding with a central opening at the bottom of the casing for the purpose of evacuating the solid matters, such as sugar. In this arrangement also, the driving-gear, supported by the upper framing, is set at about the level of the centrifugal. The upper part of the driving-gear is therefore limited, of necessity, by the horizontal beam of the drum, on which the driving-belt from the general gearing of the different apparatus passes. Seen in this light, it is evident that the Weston centrifugal labors under serious disadvantages, such as the necessity of costly framing capable of resisting the trepidatory and vibratory motions arising from the high speed of rotation of the apparatus to which it is suspended, the obstruction of the works caused as well by the framing as by the gearing situated at a still lower level, (about man's height,) irrespective

of the danger attending machinery under these circumstances.

These disadvantages account for, naturally and justly, the objections and resistance of manufacturers to adopt this system, particularly on the part of those which form the majority, whose works, being already erected, would require such extensive and inconvenient changes. With a view to remedy these inconveniences, I have invented the following arrangement of parts, which do not in any way affect the recognized advantages of the Weston centrifugal.

In order that my improvements may be clearly understood I will now describe their construction, conjointly with the accompanying sheet of drawing, in which—

Figure 1 is a plan of the same; Fig. 2, an elevation of upper part of the machine, representing the driving-gear; and Fig. 3, an elevation in section of the complete machine.

The same letters serve to illustrate the same parts in all the views.

A is a cast-iron casing cast in one piece, with a pedestal, in order to bring it up to the desired height. This casing is bolted by its four ears to solid masonry in exactly the same manner as the ordinary centrifugal machines. In this manner it becomes the basis and the support of all the working parts which are suspended from the arched frame-work B. Apertures are formed in the pedestal in order to extract the solid matter discharged through the central valve of the drum, as is well known, and which is collected either in a little vat on wheels, placed to this end under the machine, or, in the case of many machines placed in line, on an endless band or chain, which transports all these products to a common store-room. The arched frame B, which is firmly bolted to the casing, so as to form one rigid whole, is composed of three curved standards, at the point of junction of which is suspended the bearing of the drum F, which is hung, as in the Weston machine, with its vertical shaft C, its horizontal pulley D, and brake E. On the third support are mounted, at a proper distance to insure by its twisting a change in the direction of the belt, two guide-pulleys, G and H, which are arranged in such a manner as to always have their plane in the two

planes of movement of the belt, and consequently be able to maintain itself properly, both, on the one hand, on the horizontal pulley D, and, on the other, on the vertical pulley composing the general gearing of the apparatus. This main gearing is then fixed at the top of the building, and the belts of the machines, on leaving the guide-pulleys, rise directly to the same, instead of continuing horizontally, as is the case with the Weston arrangement.

I use the same friction-clutch as Weston to drive the centrifugal and place it on the special driving-shaft, from which its lever is brought in proximity to the attendant, either by means of a rod or of a rope. The advantages of this novel combination will be at once clearly seen. First, an apparatus uniting within itself solidly together all the necessary moving organs, firmly fixed to and having its center of gravity on the ground itself—conditions which are always preferable in the case of machines working at a high speed; secondly, I avoid the necessity of any special construction of columns and frame-work of iron or wood, which have to be strongly bolted and braced together in order to bear safely all the gearing suspended

from the same; lastly, there is no obstruction as to space occupied, light, or facility of circulating in the work-shops. Thus this erection and arrangement are perfectly adapted to all kinds of works, and more particularly to replace the thousands of centrifugal machines already existing in actual sugar-works and refineries, by merely fixing it in the position occupied by the former one, and keying on the existing driving-shaft the frictional clutch-pulley to drive the same.

Having thus explained the nature of my improvements, I claim as my invention and desire to secure by Letters Patent—

1. The construction and arrangement of parts described for adapting a Weston centrifugal entirely to one casing bolted to the floor without any additional framing or support.

2. The arrangement of the guide-pulleys G and H, adapted to the standards of the said casing, in connection with the horizontal driving-pulley D, to which motion is imparted from a main horizontal shaft above.

A. CHENU.

Witnesses:

F. ALCOTT,
A. H. BRANDON.