



(51) International Patent Classification:
B41J 3/36 (2006.01)

(21) International Application Number:
PCT/EP2019/066805

(22) International Filing Date:
25 June 2019 (25.06.2019)

(25) Filing Language: English

(26) Publication Language: English

(30) Priority Data:
18179493.4 25 June 2018 (25.06.2018) EP

(71) Applicant: COLOP DIGITAL GMBH [AT/AT]; Dr.-
Arming-Straße 5, 4600 Wels (AT).

(72) Inventor: BRETON, Alex; Lindevägen 126 3TR, 120 48
Enskede Gard (SE).

(74) Agent: SONN & PARTNER PATENTANWÄLTE;
Riemergasse 14, 1010 Vienna (AT).

(81) Designated States (unless otherwise indicated, for every kind of national protection available): AE, AG, AL, AM, AO, AT, AU, AZ, BA, BB, BG, BH, BN, BR, BW, BY, BZ, CA, CH, CL, CN, CO, CR, CU, CZ, DE, DJ, DK, DM, DO, DZ, EC, EE, EG, ES, FI, GB, GD, GE, GH, GM, GT, HN, HR, HU, ID, IL, IN, IR, IS, JO, JP, KE, KG, KH, KN, KP, KR, KW, KZ, LA, LC, LK, LR, LS, LU, LY, MA, MD, ME, MG, MK, MN, MW, MX, MY, MZ, NA, NG, NI, NO, NZ, OM, PA, PE, PG, PH, PL, PT, QA, RO, RS, RU, RW, SA, SC, SD, SE, SG, SK, SL, SM, ST, SV, SY, TH, TJ, TM, TN, TR, TT, TZ, UA, UG, US, UZ, VC, VN, ZA, ZM, ZW.

(84) Designated States (unless otherwise indicated, for every kind of regional protection available): ARIPO (BW, GH, GM, KE, LR, LS, MW, MZ, NA, RW, SD, SL, ST, SZ, TZ, UG, ZM, ZW), Eurasian (AM, AZ, BY, KG, KZ, RU, TJ, TM), European (AL, AT, BE, BG, CH, CY, CZ, DE, DK, EE, ES, FI, FR, GB, GR, HR, HU, IE, IS, IT, LT, LU, LV, MC, MK, MT, NL, NO, PL, PT, RO, RS, SE, SI, SK, SM, TR), OAPI (BF, BJ, CF, CG, CI, CM, GA, GN, GQ, GW, KM, ML, MR, NE, SN, TD, TG).

(54) Title: ELECTRONIC HAND STAMP

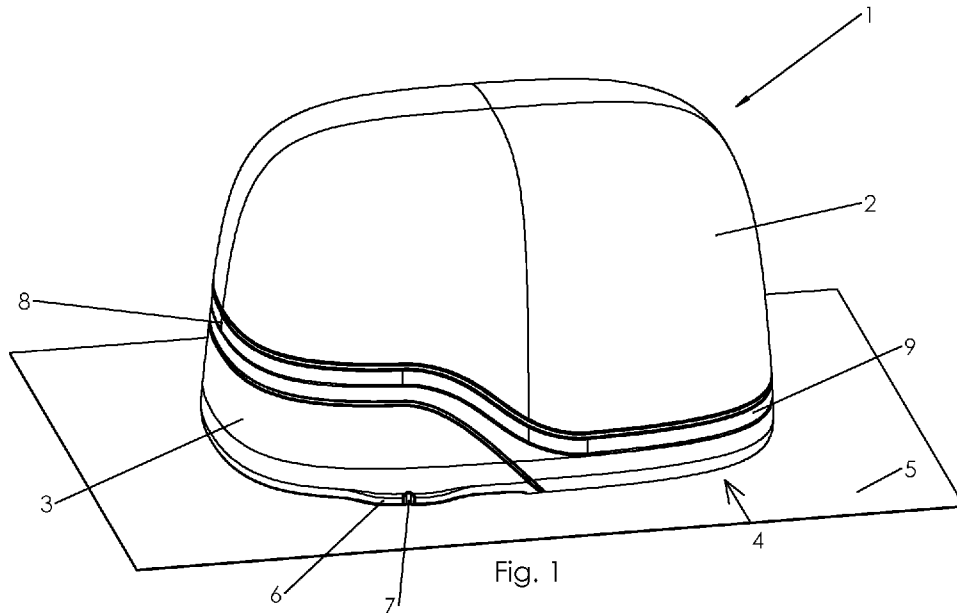

Fig. 1

(57) Abstract: Electronic hand stamp (1) comprising: an inkjet printhead with nozzles directed toward a bottom side (4) of the electronic hand stamp (1), a control circuit (30) and a motion detector, wherein the control circuit (30) is connected to the motion detector and to the inkjet printhead and configured to control the inkjet printhead in response to readings received from the motion detector, wherein the electronic hand stamp (1) comprises at least four indicator LEDs (10-17) connected to the control circuit (30), wherein at least one of the at least four indicator LEDs (10-17) is arranged on every side perpendicular to the bottom side (4) of the electronic hand stamp (1).



Declarations under Rule 4.17:

- *as to applicant's entitlement to apply for and be granted a patent (Rule 4.17(ii))*
- *of inventorship (Rule 4.17(iv))*

Published:

- *with international search report (Art. 21(3))*

Electronic hand stamp

The invention concerns an electronic hand stamp and a method for controlling the same. An electronic hand stamp generally is a portable electronic device for producing stamp marks by printing on a substrate (e.g. a document or other object to be stamped). An electronic hand stamp of the present type comprises an inkjet printhead with nozzles directed toward a bottom side of the electronic hand stamp, a control circuit and a motion detector, wherein the control circuit is connected to the motion detector and to the inkjet printhead and configured to control the inkjet printhead in response to readings received from the motion detector, thereby producing a printed image when the electronic hand stamp is manually moved over the substrate.

The present electronic hand stamp can be used as an electronic replacement for traditional (mechanical) hand stamps with rubber stamp plates and ink pads. It transfers a pre-defined image (the motif) to a substrate, which typically already holds information. The information in the motif augments the information already present on the substrate.

For a similar purpose, US 4,947,262 A shows a hand-held manually sweeping printing apparatus. The apparatus has a thermal printer head and a roll of a thermal-transfer ink ribbon. The apparatus comprises three LEDs (light-emitting diodes): a power-supply pilot lamp, a memory pilot lamp and an alarm lamp. Each LED indicates only one binary status. Therefore, each status indicated by one of the LEDs is visible only from one side of the apparatus. In particular, error states or warnings concerning the printer operation might not be recognizable by the user during the printer operation, depending on how the apparatus is positioned and held.

Other portable electronic devices with the ability to print are known, albeit for a different purpose. Specifically, portable printer-scanner devices are known, which serve as a means for replicating existing documents. Such devices typically operate on a first substrate holding information by scanning said information without modifying the first substrate; subsequently they operate on a second substrate that is empty (does not hold

information) and print a copy of the scanned information on the second substrate.

Examples of such devices are shown in US 7,426,050 B2, in DE 103 53 875 A1 and in DE 10 2005 014 227 B4.

US 2007/147930 A1 discloses a printing device including light guides to assist the user in aligning the device with a reference, such as the edge of a page.

It is an object of the present invention, to provide for a reliable user feedback means that can be noticed during operation, thereby facilitating error-free use of the electronic hand stamp.

The invention proposes an electronic hand stamp of the kind stated in the outset, wherein the electronic hand stamp comprises at least four indicator LEDs connected to the control circuit, wherein at least one of the at least four indicator LEDs is arranged on every side perpendicular to the bottom side of the electronic hand stamp. The indicator LEDs are visible from every side or angle. Thus, the information indicated by the indicator LEDs is visible irrespective of the current position of the electronic hand stamp or the grasp thereon.

Correspondingly, the invention proposes a method for controlling an electronic hand stamp as defined above, wherein the at least four indicator LEDs are controlled in an interdependent fashion. In other words, the indicator LEDs are not configured to indicate operationally independent signals, but to cooperate in order to together indicate the same one or more signals concerning the operating status of the electronic hand stamp.

In a preferred embodiment, the electronic hand stamp comprises at least six indicator LEDs, preferably at least eight indicator LEDs, connected to the control circuit. A larger number of indicator LEDs increases the visibility of the indicator LEDs and thus - because they all basically indicate the same information - of the indicated operating status.

Advantageously, the indicator LEDs are multicolour LEDs (e.g.

RGB LEDs), wherein the control circuit is configured to control the indicator LEDs to glow in the same colour, in particular either simultaneously or time-delayed (in an animation). By using multicolour LEDs, the number and arrangement of LEDs can be improved compared to a corresponding larger number of single-color LEDs. In particular, a smaller number of LEDs can indicate a comparably larger number of operating statuses by colour-encoding.

The electronic hand stamp may further comprise a diffuser, wherein at least two indicator LEDs are optically connected with the diffuser. The diffuser blurs the gap or limit between two adjacent LEDs; the diffuser typically includes a light guide and a scattering surface. The scattering surface might be formed by a diffusion filter (e.g. milk glass or similar plastics material).

In this context, it is advantageous, if the distance between the indicator LEDs is small enough that the brightness of the LED-light through the diffuser is essentially homogeneous. Essentially homogeneous here means that the brightness of the emitted light does not drop below 70 % of the maximum brightness under full-power conditions, optionally the brightness of the emitted light does not drop below 90 % of the maximum brightness under full-power conditions.

When all of the at least four indicator LEDs are optically connected with the diffuser, and in particular the diffuser circumferentially surrounds the electronic hand stamp, a continuous light strip can be formed. The light strip may be arranged to surround the outer side walls of the electronic hand stamp.

It has turned out beneficial, if the at least four indicator LEDs are arranged on two or more printed circuit boards (PCBs). Two or more printed circuit boards may preferably be arranged perpendicular to the bottom side of the electronic stamp (i.e. in a vertical arrangement, short "vertical PCB"). Using printed circuit boards as supports for the LEDs has several advantages: they provide a cost effective surface mount process and an easy connection to a control circuit. Rigid PCBs as well as flexible

PCBs can be used.

At least one of the PCBs can be a horizontal PCB, wherein the one or more indicator LEDs arranged thereon are right angle LEDs. Moreover, at least one indicator LED can be arranged on a flexible PCB, wherein the flexible PCB is preferably extending from and connected to a vertical PCB.

In a particularly preferred embodiment, the electronic hand stamp comprises at least one target LED (or substrate-lightning LED) for illuminating a print area adjacent the printhead, said at least one target LED being connected to the control circuit. Preferably at least two target LEDs are foreseen, e.g. one on each of opposite sides of the printhead. Illumination of the print area helps in aligning the electronic hand stamp with respect to the substrate, in particular with respect to an existing layout of the substrate (e.g. form fields indicated on a pre-printed paper form).

In this context, the at least two target LEDs are preferably connected to the control circuit, wherein the control circuit is configured to switch on at least one target LED on one of the sides of the printhead, preferably the side corresponding to the direction in which the printhead is being moved. This control of the target LEDs helps to avoid ambiguities concerning the alignment of one of the two sides of the printhead with respect to the substrate. Also, it provides feedback to the user concerning the motion detection performed by the electronic hand stamp by indicating the direction in which the stamp assumes it is moved.

Advantageously, the at least one target LED is optically connected to a prism for deflecting light emitted by the at least one target LED to the print area. The use of a prism allows for the target LED to be supported on the same PCB as one or more of the indicator LEDs, which are configured to emit light not at the print area (facing the bottom side) but to the vertical sides of the electronic hand stamp.

With regard to the inventive method, it is preferred, that the method comprises controlling the at least four indicator LEDs to

simultaneously glow in a predefined colour to indicate an operating status of the stamp. For example, the operating status is a member selected from a group consisting of: power-on, battery weak/empty, ink empty, other error, connection established, and transfer finished. The control of the electronic hand stamp can be configured to use different predefined colours, each associated with one of the operating statuses. When the electronic hand stamp reaches an operating status associated with an indication by the indicator LEDs, the indicator LEDs are controlled to all glow in the predefined colour associated with said operating status (e.g. all glowing green upon power-on).

With further regard to the inventive method, the method may particularly comprise controlling the at least four indicator LEDs to glow in a time-delayed fashion and in order of their circumferential arrangement, preferably for at least one turn, to indicate an ongoing operation. For example, the LEDs are controlled to flash at a common frequency and with a phase shift that is larger between more distant LEDs than between adjacent LEDs. To provide an indication that is readily understandable from any side of the electronic hand stamp, it is advantageous, if the flashing of the LEDs and the time delay are configured such that the appearance of a rotating light is created. The ongoing operation can be a member selected from a group consisting of: transfer in progress, and printing in progress. For example, during a transfer of image data from a host device to the electronic hand stamp, the indicator LEDs may be controlled to signal a rotating blue light that stops once the transfer is finished.

With respect to the use of target LEDs, the present method may preferably comprise switching on at least one target LED on one of the sides of the printhead, preferably the side corresponding to the direction in which the printhead is being moved when a direction of movement of the electronic hand stamp is detected, and switching off the other target LEDs.

Referring now to the drawings, wherein the figures are for purposes of illustrating the present invention and not for purposes of limiting the same,

- 6 -

fig. 1 schematically shows a figurative view of an electronic hand stamp according to the present invention,

fig. 2 schematically shows a partial figurative view of the electronic hand stamp according to fig. 1 in an opened configuration,

fig. 3 schematically shows a horizontal cut of the electronic hand stamp according to figures 1 and 2, and

fig. 4 shows a bottom view of the electronic hand stamp according to the previous figures.

Fig. 1 shows an electronic hand stamp 1 having a generally opaque cover 2 with a windowed portion 3 and a bottom side 4. The windowed portion 3 is made of a transparent material. In the operating position shown in fig. 1, the electronic hand stamp 1 is positioned with its bottom side 4 flat on a plane substrate 5. In this position, an inkjet printhead (not shown) has its nozzles directed toward the bottom side 4 and the substrate 5 in order to print thereon. The inkjet printhead is controlled by a control circuit 30 (see fig. 2) integrated in the electronic hand stamp 1. The control circuit 30 is connected to a motion detector, for example an optical sensor directed at the substrate 5, a gyroscope and/or an accelerometer, and configured to received readings from the motion detector and control the inkjet printhead in response to those readings. Specifically, the control is configured to produce an undistorted print image irrespective of a speed of movement of the electronic hand stamp 1 relative to the substrate 5 or variations in said speed. The windowed portion 3 allows a user to supervise the printing process immediately next to the printhead. Extending from the windowed portion 3 of the cover 2, the electronic hand stamp 1 comprises indicator projections 6 on each side (compare fig. 3). The indicator projections 6 have a central notch 7 marking the centre of the arrangement of nozzles of the inkjet printhead, i.e. on a line connecting the notches 7 of the two indicator projections 6.

Embedded in the cover 2, the electronic hand stamp 1 comprises a light strip 8 (also "light pipe"). The part of the light strip 8 visible on the outside of the assembled electronic hand stamp 1 is a diffuser 9 that circumferentially surrounds the electronic hand stamp 1. The diffuser 9 comprises a diffusion filter 9'

having a light scattering surface.

Figures 2 and 3 show the other components of the light strip 8. As can be seen, the electronic hand stamp 1 comprises eight indicator LEDs 10, 11, 12, 13, 14, 15, 16, 17. Two indicator LEDs 10, 11; 12, 13; 14, 15; 16, 17 are arranged on every side of the electronic hand stamp 1 perpendicular to the bottom side 4. All eight indicator LEDs 10-17 are optically connected with a light guide 18 of the diffuser 9. The light guide 18 comprises four segments 19-22, each connected to one or more of the indicator LEDs 10-17. More specifically, the segments 19-22 of the light guide 18 together define a continuous outer surface 23, on which the diffusion filter 9' of the diffuser 9 is attached. The diffusion filter 9' may be for example a scattering foil adhered to the continuous outer surface 23. The segments 19-22 comprise a main portion that is parallel to the continuous outer surface 23 and from which legs 24 extend to each of the connected indicator LEDs 10-17. Each leg 24 at its end facing the respective indicator LED 10-17 has a flat end surface 25 that is perpendicular to the principal direction of light emitted from the respective indicator LED 10-17. This arrangement provides for an efficient coupling of light into the light guide 18.

The distance between the indicator LEDs 10-17 is small enough that the brightness of the LED-light through the diffuser 9 is essentially homogeneous. The homogeneous distribution of light is achieved by total internal reflection in the light guide 18 and partial back scattering from the diffusion filter 9' into the light guide 18. The scattering of the light can optionally be improved by using a material which contains scattering particles for the light guide 18. However, a homogeneous distribution can also be achieved without scattering, a scattering surface or scattering particles. Hence, it is those two elements and their respective optical properties that define the number of indicator LEDs required to homogeneously illuminate or "supply" a given length of the light strip 8. Another influence is the optical coupling between adjacent segments 19-22 of the light guide 18 parallel to the continuous outer surface 23.

The indicator LEDs 10-17 are arranged on two vertical printed circuit boards (PCBs) 26, 27, one horizontal PCB 28 and one flexible PCB 29 extending from one of the vertical PCBs 27. All indicator LEDs 10-17 are connected to a common control circuit 30 arranged on one or more of the PCBs 26. Accordingly, all PCBs 26-29 are electronically connected, e.g. with a common bus system. The indicator LEDs 12, 13 arranged on the horizontal PCB 28 are right angle LEDs, i.e. having a principal light emission direction parallel to the principal plane of the horizontal PCB 28. All eight indicator LEDs 10-17 are multicolour LEDs. The control circuit 30 is configured to control the indicator LEDs 10-17 in an interdependent fashion, for example to glow in the same colour, in particular either simultaneously or time-delayed.

In addition to the indicator LEDs 10-17, the electronic hand stamp 1 comprises two target LEDs 31, 32, one on each of the vertical PCBs 26, 27. The target LEDs 31, 32 are bright white-light LEDs that are each optically connected to a respective prism 33, 34 for deflecting light emitted by the associated target LED 31, 32 to the print area on the substrate 5 adjacent the printhead, thereby illuminating the print area. The target LEDs 31, 32 are connected to the control circuit 30 of the electronic hand stamp 1. The control circuit 30 is configured to switch on the target LED 31; 32 on the side of the printhead corresponding to the direction in which the printhead is being moved (according to the reading of the motion sensor).

Fig. 4 shows a view from below onto the bottom side 4 of the electronic hand stamp 1. The printhead 36 is positioned essentially centred between the prisms 33, 34 of the target LEDs 31, 32. Motion of the electronic hand stamp 1 is detected with an optical motion detector 35, which is in principle similar to detectors used for optical computer mice. During printing, the electronic hand stamp 1 is moved in one or the other direction along an essentially linear axis of motion 37. A row of inkjet nozzles of the printhead 36 is arranged perpendicular to the axis of motion 37. The rollers 38 guide and help to maintain a straight path of movement during printing, i.e. along the axis of motion 37.

Claims:

1. Electronic hand stamp (1) comprising:
an inkjet printhead with nozzles directed toward a bottom side (4) of the electronic hand stamp (1),
a control circuit (30) and
a motion detector,
wherein the control circuit (30) is connected to the motion detector and to the inkjet printhead and configured to control the inkjet printhead in response to readings received from the motion detector,
characterized in that the electronic hand stamp (1) comprises at least four indicator LEDs (10-17) connected to the control circuit (30), wherein at least one of the at least four indicator LEDs (10-17) is arranged on every side perpendicular to the bottom side (4) of the electronic hand stamp (1).
2. Electronic hand stamp (1) according to claim 1, characterized in that the electronic hand stamp (1) comprises at least six indicator LEDs (10-17) connected to the control circuit (30).
3. Electronic hand stamp (1) according to claim 2, characterized in that the electronic hand stamp (1) comprises at least eight indicator LEDs (10-17) connected to the control circuit (30).
4. Electronic hand stamp (1) according to one of claims 1 to 3, characterized in that the indicator LEDs (10-17) are multicolour LEDs, wherein the control circuit (30) is configured to control the indicator LEDs (10-17) to glow in the same colour.
5. Electronic hand stamp (1) according to claim 4, characterized in that the control circuit (30) is configured to control the indicator LEDs (10-17) to glow in the same colour either simultaneously or time-delayed.
6. Electronic hand stamp (1) according to one of the preceding claims, characterized in that the electronic hand stamp (1) comprises a diffuser (9), wherein at least two indicator LEDs (10-17) are optically connected with the diffuser (9).

7. Electronic hand stamp (1) according to claim 6, characterized in that the distance between the indicator LEDs (10-17) is small enough that the brightness of the LED-light through the diffuser (9) is essentially homogeneous.

8. Electronic hand stamp (1) according to claim 6 or 7, characterized in that all of the at least four indicator LEDs (10-17) are optically connected with the diffuser (9).

9. Electronic hand stamp (1) according to claim 8, characterized in that the diffuser (9) circumferentially surrounds the electronic hand stamp (1).

10. Electronic hand stamp (1) according to one of the preceding claims, characterized in that the at least four indicator LEDs (10-17) are arranged on two or more printed circuit boards (26-29).

11. Electronic hand stamp (1) according to one of the preceding claims, characterized in that at least one target LED (31, 32) for illuminating a print area adjacent the printhead is connected to the control circuit (30).

12. Electronic hand stamp (1) according to claim 11, characterized in that at least two target LEDs (31, 32) for illuminating a print area adjacent the printhead are connected to the control circuit (30).

13. Electronic hand stamp (1) according to claim 12, characterized in that the at least two target LEDs (31, 32) are connected to the control circuit (30), wherein the control circuit (30) is configured to switch on at least one target LED (31; 32) on one of the sides of the printhead.

14. Electronic hand stamp (1) according to claim 13, characterized in that the control circuit (30) is configured to switch on at least one target LED (31; 32) on the side of the printhead corresponding to the direction in which the printhead is being moved.

15. Electronic hand stamp (1) according to one of claims 11 to

14, characterized in that the at least one target LED (31, 32) is optically connected to a prism (33, 34) for deflecting light emitted by the at least one target LED (31, 32) to the print area.

16. Method for controlling an electronic hand stamp (1) according to claim 1, characterized by controlling the at least four indicator LEDs (10-17) in an interdependent fashion.

17. Method according to claim 16, characterized by controlling the at least four indicator LEDs (10-17) to simultaneously glow in a predefined colour to indicate an operating status of the electronic hand stamp (1).

18. Method according to claim 16, characterized by controlling the at least four indicator LEDs (10-17) to glow in a time-delayed fashion and in order of their circumferential arrangement to indicate an ongoing operation.

19. Method according to claim 18, characterized by controlling the at least four indicator LEDs (10-17) to glow in a time-delayed fashion and in order of their circumferential arrangement for at least one turn to indicate an ongoing operation.

20. Method for controlling an electronic hand stamp (1) according to claim 13, characterized by switching on at least one target LED (31; 32) on one of the sides of the printhead when a direction of movement of the electronic hand stamp (1) is detected, and switching off the other target LEDs (32; 32).

21. Method for controlling an electronic hand stamp (1) according to claim 20, characterized by switching on at least one target LED (31; 32) on the side of the printhead corresponding to the direction in which the printhead is being moved when a direction of movement of the electronic hand stamp (1) is detected, and switching off the other target LEDs (32; 32).

1/4

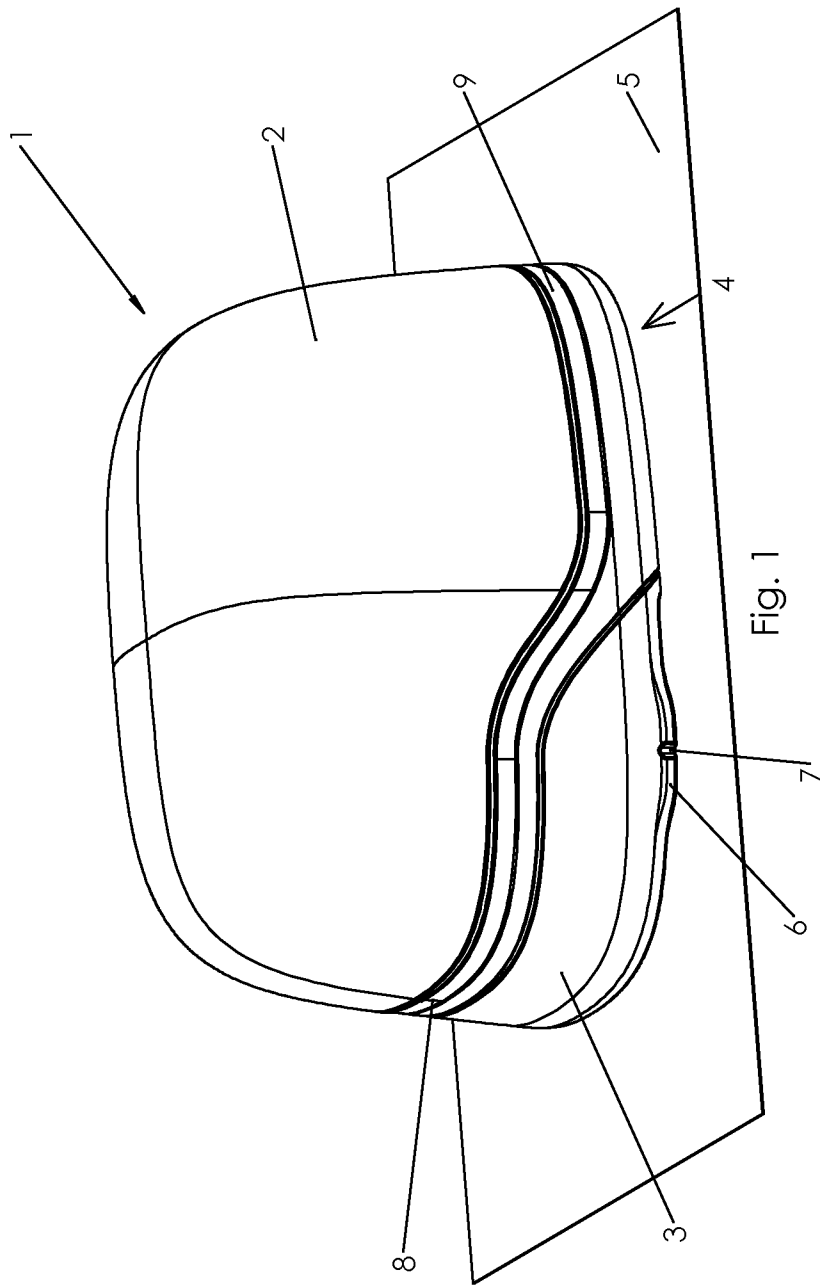

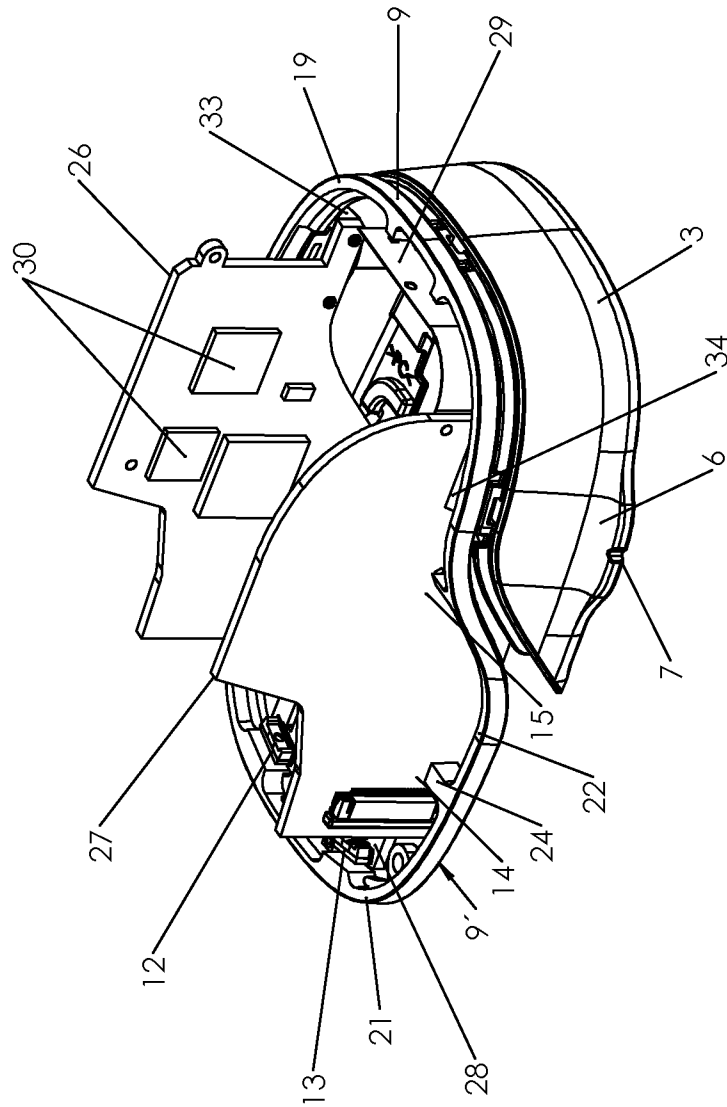

Fig. 2

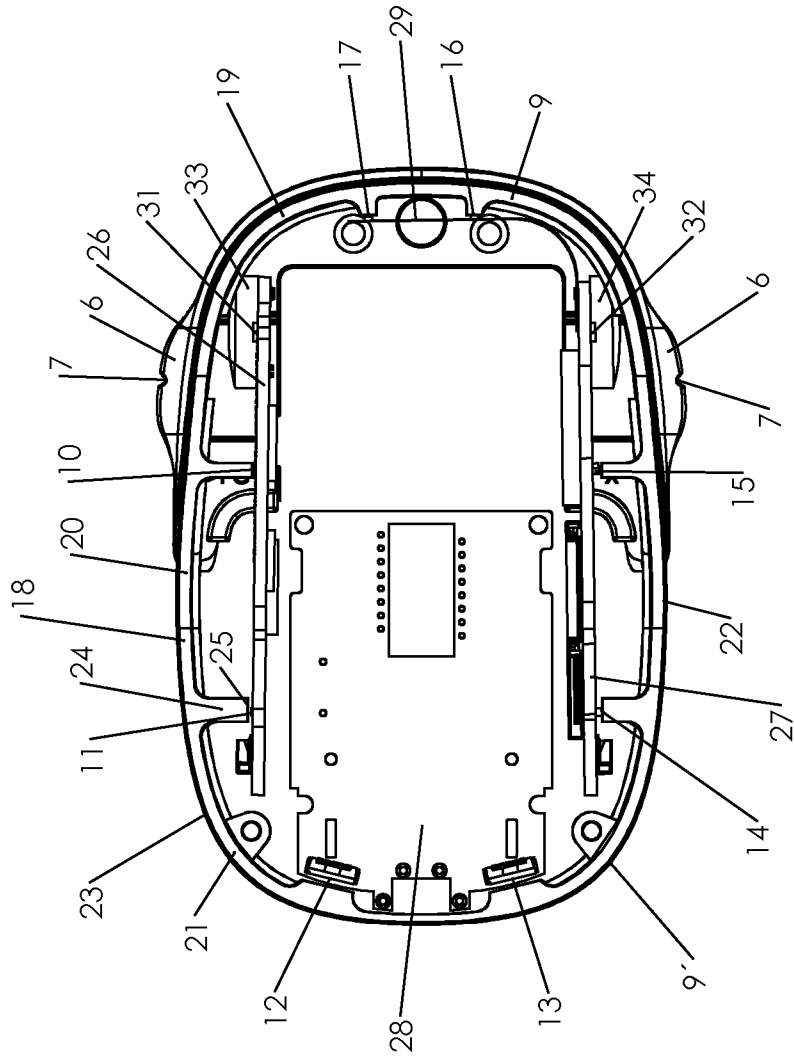

Fig. 3

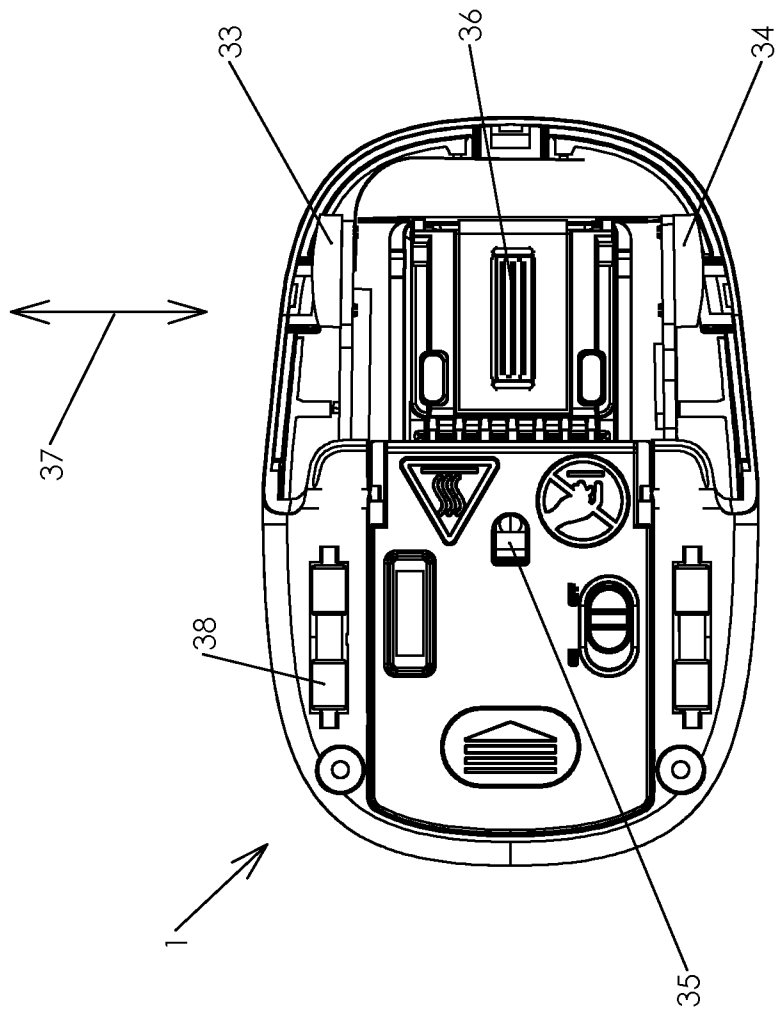

Fig. 4

INTERNATIONAL SEARCH REPORT

International application No
PCT/EP2019/066805

A. CLASSIFICATION OF SUBJECT MATTER
INV. B41J3/36
ADD.

According to International Patent Classification (IPC) or to both national classification and IPC

B. FIELDS SEARCHED
Minimum documentation searched (classification system followed by classification symbols)
B41J

Documentation searched other than minimum documentation to the extent that such documents are included in the fields searched

Electronic data base consulted during the international search (name of data base and, where practicable, search terms used)
EPO-Internal, WPI Data

C. DOCUMENTS CONSIDERED TO BE RELEVANT		
Category*	Citation of document, with indication, where appropriate, of the relevant passages	Relevant to claim No.
X	US 2007/147930 A1 (NISHATH SOGRA [US] ET AL) 28 June 2007 (2007-06-28)	1-7, 10-17, 20,21
A	paragraphs [0001], [0005] - [0007], [0014] - [0017], [0020], [0023], [0025] - [0027]; figures 1-4	8,9,18, 19
A	----- US 2005/088683 A1 (SILVERBROOK KIA [AU]) 28 April 2005 (2005-04-28) paragraphs [0001], [0007] - [0017], [0050], [0054], [0055]; figures 1, 4	1-21
A	----- US 2003/106447 A1 (WALLING ALEX [SE]) 12 June 2003 (2003-06-12) paragraphs [0001], [0002], [0031] - [0035], [0040]; figures 1-4, 6	1-21
	----- -/--	

Further documents are listed in the continuation of Box C.

See patent family annex.

* Special categories of cited documents :

"A" document defining the general state of the art which is not considered to be of particular relevance

"E" earlier application or patent but published on or after the international filing date

"L" document which may throw doubts on priority claim(s) or which is cited to establish the publication date of another citation or other special reason (as specified)

"O" document referring to an oral disclosure, use, exhibition or other means

"P" document published prior to the international filing date but later than the priority date claimed

"T" later document published after the international filing date or priority date and not in conflict with the application but cited to understand the principle or theory underlying the invention

"X" document of particular relevance; the claimed invention cannot be considered novel or cannot be considered to involve an inventive step when the document is taken alone

"Y" document of particular relevance; the claimed invention cannot be considered to involve an inventive step when the document is combined with one or more other such documents, such combination being obvious to a person skilled in the art

"&" document member of the same patent family

Date of the actual completion of the international search 13 August 2019	Date of mailing of the international search report 21/08/2019
Name and mailing address of the ISA/ European Patent Office, P.B. 5818 Patentlaan 2 NL - 2280 HV Rijswijk Tel. (+31-70) 340-2040, Fax: (+31-70) 340-3016	Authorized officer Bitane, Rehab

INTERNATIONAL SEARCH REPORT

International application No
PCT/EP2019/066805

C(Continuation). DOCUMENTS CONSIDERED TO BE RELEVANT		
Category*	Citation of document, with indication, where appropriate, of the relevant passages	Relevant to claim No.
A	US 7 481 528 B2 (RD & IP L L C) 27 January 2009 (2009-01-27) column 5, lines 31-62; figure 2 -----	1-21

INTERNATIONAL SEARCH REPORT

Information on patent family members

International application No PCT/EP2019/066805

Patent document cited in search report		Publication date	Patent family member(s)	Publication date
US 2007147930	A1	28-06-2007	NONE	
US 2005088683	A1	28-04-2005	AU 2003202629 A1	04-09-2003
			CA 2483499 A1	21-08-2003
			CN 1631031 A	22-06-2005
			EP 1483895 A1	08-12-2004
			JP 4260022 B2	30-04-2009
			JP 2005518156 A	16-06-2005
			JP 2009107346 A	21-05-2009
			KR 20040102358 A	04-12-2004
			US 2005088683 A1	28-04-2005
			US 2008291258 A1	27-11-2008
			US 2011298861 A1	08-12-2011
			WO 03069890 A1	21-08-2003
			ZA 200406416 B	27-09-2005
US 2003106447	A1	12-06-2003	AU 6966201 A	14-01-2002
			EP 1296836 A1	02-04-2003
			US 2003106447 A1	12-06-2003
			WO 0202343 A1	10-01-2002
US 7481528	B2	27-01-2009	NONE	