

(19) World Intellectual Property Organization
International Bureau



(43) International Publication Date
24 May 2007 (24.05.2007)

PCT

(10) International Publication Number
WO 2007/058543 A1

(51) International Patent Classification:
E05D 15/40 (2006.01) *E05D 7/10* (2006.01)
E05D 15/44 (2006.01)

(21) International Application Number:
PCT/NO2006/000419

(22) International Filing Date:
16 November 2006 (16.11.2006)

(25) Filing Language: Norwegian

(26) Publication Language: English

(30) Priority Data:
2005 5425 16 November 2005 (16.11.2005) NO

(71) Applicant (for all designated States except US): AS
SPILKA INDUSTRI [NO/NO]; Emblem, N-6013 Ålesund (NO).

(72) Inventor; and

(75) Inventor/Applicant (for US only): VATN, Per-Idar
[NO/NO]; Skåtadalen 18, N-6012 Ålesund (NO).

(74) Agent: ACAPO AS; Strandgt. 198, P.O. Box 1880
Nordnes, N-5817 Bergen (NO).

(81) Designated States (unless otherwise indicated, for every kind of national protection available): AE, AG, AL, AM, AT, AU, AZ, BA, BB, BG, BR, BW, BY, BZ, CA, CH, CN, CO, CR, CU, CZ, DE, DK, DM, DZ, EC, EE, EG, ES, FI, GB, GD, GE, GH, GM, GT, HN, HR, HU, ID, IL, IN, IS, JP, KE, KG, KM, KN, KP, KR, KZ, LA, LC, LK, LR, LS, LT, LU, LV, LY, MA, MD, MG, MK, MN, MW, MX, MY, MZ, NA, NG, NI, NO, NZ, OM, PG, PH, PL, PT, RO, RS, RU, SC, SD, SE, SG, SK, SL, SM, SV, SY, TJ, TM, TN, TR, TT, TZ, UA, UG, US, UZ, VC, VN, ZA, ZM, ZW.

(84) Designated States (unless otherwise indicated, for every kind of regional protection available): ARIPO (BW, GH, GM, KE, LS, MW, MZ, NA, SD, SL, SZ, TZ, UG, ZM, ZW), Eurasian (AM, AZ, BY, KG, KZ, MD, RU, TJ, TM), European (AT, BE, BG, CH, CY, CZ, DE, DK, EE, ES, FI, FR, GB, GR, HU, IE, IS, IT, LT, LU, LV, MC, NL, PL, PT, RO, SE, SI, SK, TR), OAPI (BF, BJ, CF, CG, CI, CM, GA, GN, GQ, GW, ML, MR, NE, SN, TD, TG).

Published:
— with international search report

For two-letter codes and other abbreviations, refer to the "Guidance Notes on Codes and Abbreviations" appearing at the beginning of each regular issue of the PCT Gazette.

(54) Title: WINDOW MOUNTING

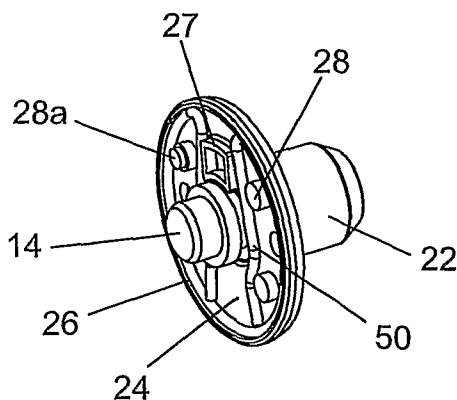

(57) Abstract: A mid-frame mounting (20) for fastening of a window hinge (12) to a window frame is described, comprising an internal, at least partially open, casing part (22) arranged for insertion in a boring in the side edge of the window frame, and also fastening to same, and where the casing part (22) is arranged to lockable receive a pintle (14) of the window hinge (12). The casing part (20) comprises a collar (24) with an inserted spring (40;50) arranged at least partially to encompass and to releasable retain said pintle (14) in the mid-frame mounting (20), as the spring means (40;50) is arranged to clamp against and lie in at least parts of a groove (16) in said pintle (14).



WO 2007/058543 A1

WINDOW MOUNTING

The present invention relates to a mid-frame mounting for fastening of a window hinge to a window frame comprising an internal, at least partially open, casing part arranged to be inserted in a boring in the side edge of the window frame, and also fastening to the same, and where the casing part is arranged to lockable receive a pintle of the window hinge, the casing part comprises a collar with a spring arranged, at least, to partially encompass and to retain said pintle in the mid-frame mounting so that it can be released.

Known mid-frame mountings are, in the main, formed in a long shape that are screwed into a cut out/boring in the side edge of the window frame, and which comprise a gliding locking part or one-sided spring which clamps against parts of the pintle of the window hinge. To lock the pintle in the mid-frame mounting, the locking part is pushed to one side of the pintle and is thereafter locked by tightening a screw or the like. Release is carried out the opposite way, i.e. the screw is made loose and the locking part or the one-sided spring is pulled away from the pintle.

From prior art is known, among others from a product data sheet from Intropia AS "Middle-mounting with locking loop", a middle-mounting with a locking loop in the form of a U-shaped spring which is placed in a collar-like casing part and where a groove of a fitted pintle constitutes locking of the pintle when it is pressed into the casing part of the mounting. From a product data sheet from Steelform Scandinavia AS "Middle-mounting with automatic locking", a mid-frame mounting where the casing part is made up of a collar-like construction and with elastic fastening appliances is known. Furthermore, from a product data sheet from AS Spilka Industry "Mid-frame mounting", a mid-frame mounting with a pintle catch is known.

With the present solution one aims to provide a considerably simpler and better construction. With the mid-frame mounting according to the invention a solution is provided which is independent of the choice of profile of the side frame, something which ensures that it is very simple for the factories to use the mounting. Furthermore, the cutting out/boring for the mounting takes place in one operation, something which is a great advantage for the window producers.

The mounting is screwed in place to the frame and normally does not need to be dismantled again. At the coupling together of frame and casing, the pintle of the window hinge is pressed into the mid-frame mounting and the pin is then locked by a spring means. This results in a coupling which is simple to produce.

The spring in the mid-frame mounting is constructed in such a way that it shall retain its elasticity, and preferably be clamped in the bottom of the slit/groove in the pintle of the hinge. The spring means is made in one part to achieve maximum spring characteristics, and is in addition, easy to fit when the mounting is mounted together.

An opening or slit is made in the mid-frame mounting, where one must use a tool that forces the spring apart, for it to be possible to dismantle the hinge and the mid-frame mounting.

The shape of the spring means it engages at least two sides of the pintle, something which is previously not known from similar mountings. The advantage with this is that a very good connection to the groove in the pin is achieved, something which makes the mounting much safer. It is also a huge advantage that the mounting becomes considerably stronger as one gets the forces more evenly distributed on the mounting than with a single spring engagement point.

In one preferred embodiment the mid-frame mounting is circular or round, and because of the round shape, the mounting can be rotated and fastened in different positions. This is to make it easier to release the pintle during dismantling of the frame and gives the best possible location of the fastening screws. This also means that the mounting can easily be adapted to different hinges and profile systems. The round shape also provides the advantage that one can rotate the mounting, so that one gets a favourable location for the fastening screws according to the profile.

A preferred embodiment of the invention is characterised by the characteristic in the independent claim 1, in that the spring of the mid-frame mounting is arranged to engage on at least two sides of a groove around the pintle, and that the collar of the casing part is shaped in a circular form and incorporates an outwardly extending, circular flange, in which the spring is placed, and a lid that covers both the spring and the collar, with the lid comprising a central

opening for insertion of the pintle and also an opening or slit for access to at least parts of the spring.

Preferred alternative embodiments are characterised by the dependent claims 2-8. The spring rests preferably in the collar and is in the main arranged to be snapped onto at least two sides of the pintle. The spring can be formed in a partially circular shape with a bottom opening from which two legs run in parallel in toward the middle where the legs are arranged to be clamped against said groove in the springing pin, and where a lower part of the legs can be curved in towards each other and run on at least partially parallel.

In an alternative embodiment, the spring can be formed in a mainly U-shape with two legs, where the part of the legs that make up the main part of the U-shape is arranged to be clamped against said groove in the pintle, and where a lower part of the legs can be curved in towards each other and run on at least partially in parallel.

The lid can comprise an opening or a slit, in which the parallel parts of the lower, curved-in legs are visible and are accessible.

The casing part which is arranged to be inserted into the boring of the side edge of the window frame, is preferably shaped in a circular-cylindrical cup form, the collar has preferably a larger diameter than said cup form and the lid is correspondingly preferably shaped in a circular form and comprises openings to receive securing means for fastening of the mid-frame mounting to the window frame.

Said collar can comprise a number of pins/fastening points arranged for retention of the spring. At least one of said pins can comprise an upper, outwardly extending, additional pin arranged to fit into a corresponding opening in the lid.

The invention shall now be described in more detail with the help of the enclosed figures, in which;

Figure 1 shows a mid-frame mounting according to the invention, seen from the side.

Figure 2 shows a window hinge for connection to the mid-frame mounting.

Figures 3 and 4 shows a variant of the mid-frame mounting according to the invention, without a lid.

Figure 5 shows a second variant of the mid-frame mounting according to the invention, without a lid.

Figures 6 and 7 show respective variants of a spring to be used in the mid-frame mounting according to the invention.

Figure 8 shows a variant of a lid to be used in the mid-frame mounting according to the invention.

The figures show a mid-frame mounting 20 for fastening of a window hinge 12 to a window frame (not shown). The mid-frame mounting 20 comprises an internal, at least partially open, casing part 22 arranged to be inserted into a boring in the side edge of the window frame, and for fastening of the mid-frame mounting to the side edge. The casing part 22 is arranged to receive a pintle 14 of the window frame 12 so that it can be locked. Said pintle 14 is, in the main, formed in a known way, but can, if not already produced, comprise an outer conical part 18 to ease the insertion and retention in the casing part 22.

The mounting together of casing and frame is, in the main, carried out in a known way and is assumed to be known by one skilled in the arts. This is also the case for the construction of the window hinge. However, what separates the present invention from known solutions is the fastening of the pintle in the mid-frame mounting. After the mid-frame mounting is fastened to the side edge of the window frame, preferably in a suitable cut out/bored out groove, it is not necessary to regulate or rearrange the mid-frame mounting during the fastening of the window hinge, as this is snapped into place in one operation.

The casing part 20 comprises a collar 24 with a fitted spring means, which can be comprised of a spring or another elastic element, and which is arranged to at least partially encompass and retain said pintle 14 in the mid-frame mounting 20 so that it can be released. The spring is fitted in the mid-frame mounting 20 so that it can press against, and retain, the pintle with the built-in spring force as the sole influencing appliance, i.e. it is not necessary to tighten or loosen screws on the mid-frame mounting to mount or dismantle the window hinge. The spring means/spring 40;50 is consequently arranged to press against and lie in at least parts of a groove 16 in said pintle 14. More precisely, the spring 40;50 lie in the collar 24 and is arranged to be snapped into position in at least two sides of the pintle 16. To hold the spring in place, the collar 24 of the

casing part 22 is formed in a circular shape, or approximately circular shape, and encompasses an outwardly extending circular flange 26, in which the spring 40;50 is placed, and a lid 30 that covers both the spring 40;50 and the collar 24.

Figure 3 shows the pintle 14 being forced into the mounting (the lid is removed to simplify the illustration). The end of the pintle, with the conical pin part 18, forces the spring outward. Thereafter, as shown in figure 4, the legs of the spring are snapped around at least parts of the groove 16 in the pintle.

Two alternative embodiments are shown in this application, but it must be understood that springs of different shapes than what is shown here can also be used. In an alternative embodiment, as shown in figure 6, the spring 40 is formed in a mainly U-shape with two legs 42,44. The part of the legs that constitutes the main part of the U-shape are arranged to be clamped against said groove 16 in the pintle 14. The lower parts of the legs 42,44 are curved in toward each other and run on at least partially in parallel.

In a further preferred alternative embodiment, as shown in perspective in figure 7, the spring 50 is formed with a partially circular shape 52 with a bottom opening 54, from where two legs 56,58 run in parallel in toward the middle. These legs are arranged to press against said groove 16 in the pintle 14, as shown in figure 5. As in the previous embodiment, the lower parts of the legs 60,62 are curved in towards each other and at least partially run on in parallel.

The aim of the lower, curved-in parts of the two legs is that they shall be visible and accessible in an opening or slit 32 in the lid 30, where a tool can be used to force the spring legs apart, to be able to dismantle hinges and mid-frame mountings.

The casing part 22 is, as mentioned, arranged for insertion in the boring in the side edge of the window frame and can be shaped in a circular-cylindrical cup form, with an inner conical section corresponding to the conical part 18 of the pintle. In one embodiment, the collar 24 has a larger diameter than said cup form and lies in a cut-out in the side edge of the window frame.

Correspondingly, the lid 30 must be shaped with a similar form i.e. preferably circular form, to fit into the cut-out, and the lid comprises a number of openings 34,36 to receive securing means for fastening of the mid-frame mounting 20 to

the window frame. Furthermore, the lid 30 encompasses a central opening 33 for insertion of the pintle 14.

Furthermore, the collar 24 can comprise (as shown in figure 5) a number of pins 28 arranged to retain the spring 50, in that the legs or the partially circular parts lie against said pins, so that the spring can not be rotated. For the same purpose, the collar 24 can, in addition, comprise a spacer/fastening point 27. At least one of said pins 28 can comprise an upper, outwardly extending, additional pin 28a, arranged to fit into a corresponding opening 38 in the lid 30. Alternatively (as shown in figures 3 and 4), a spacer/fastening point 29 for retention of the spring 40 can be provided in the collar 24.

CLAIMS.

1. Mid-frame mounting (20) for fastening of a window hinge (12) to a window frame comprising an internal, at least partially open, casing part (22) arranged to be inserted in a boring in the side edge of the window frame, and also fastening to same, and where the casing part (22) is arranged to lockable receive a pintle (14) of the window hinge (12), the casing part (22) comprises a collar (24) with an inserted spring (40;50) arranged at least partially to encompass and to releasable retain said pintle (14) in the mid-frame mounting (20), c h a r a c t e r i s e d i n that the spring (40;50) is arranged to engage with at least two sides of a groove (16) around said pintle (14), and that the collar (24) of the casing part (22) is formed in a circular shape and comprises an outwardly extending, circular flange (26), in which the spring (40;50) is located, and a lid (30) that covers both the spring (40;50) and the collar (24), with the lid (30) comprising a central opening (33) for insertion of the pintle (14) and also an opening or slit (32) for access to at least parts of the spring (40;50).
2. Mid-frame mounting (20) according to claim 1, c h a r a c t e r i s e d i n that the spring (40;50) rests in the collar (24) and is arranged to be snapped onto at least two sides of the pintle (14).
3. Mid-frame mounting (20) according to claim 2, c h a r a c t e r i s e d i n that the spring (50) is formed in a partially circular shape (52) with a bottom opening (54) from which two legs (56,58) run in parallel in toward the middle, where the legs are arranged to clamp against said groove (16) in the pintle (14), and that the lower parts of the legs (60,62) are curved in toward each other and run on at least partially in parallel.
4. Mid-frame mounting (20) according to claim 2, c h a r a c t e r i s e d i n that the spring (40) is formed in a mainly U-shape with two legs (42,44), where the part of the legs that makes up the main part of the U-shape is arranged to clamp against said groove (16) in the pintle (14), and that the lower parts of the legs (46,48) are curved in toward each other and run on at least partially in parallel.

5. Mid-frame mounting (20) according to claims 3 or 4, characterized in that the parallel parts of the lower, curved in legs (46,48;60,62) are visible and accessible in said opening or slit (32) in the lid (30).
6. Mid-frame mounting (20) according to one or more of the preceding claims, characterized in that the casing part (22), arranged for insertion into the boring in the side edge of the window frame, is formed in a cylindrical-circular cup form, that the collar (24) has a larger diameter than said cup form, and that the lid (30) is formed in a circular shape and comprises openings (34,36) to receive securing means for fastening the mid-frame mounting (20) to the window frame.
7. Mid-frame mounting (20) according to one or more of the preceding claims, characterized in that said collar (24) comprises a number of pins/fastening points (27,28;29) arranged to retain the spring (40;50).
8. Mid-frame mounting (20) according to claim 7, characterized in that at least one of said pins (28) comprises an upper, outwardly extending, additional pin (28a) arranged to fit into a corresponding opening (38) in the lid (30).

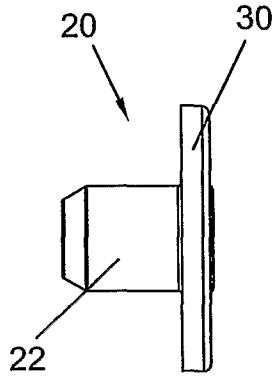

FIG. 1

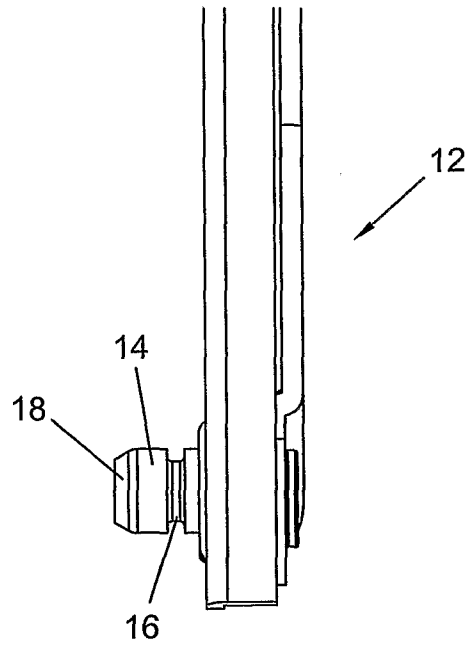

FIG. 2

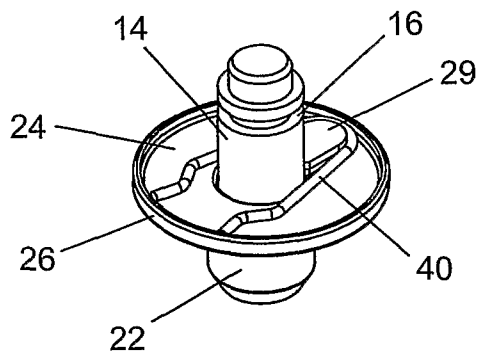

FIG. 3

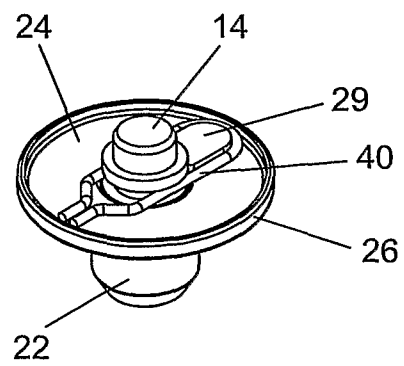

FIG. 4

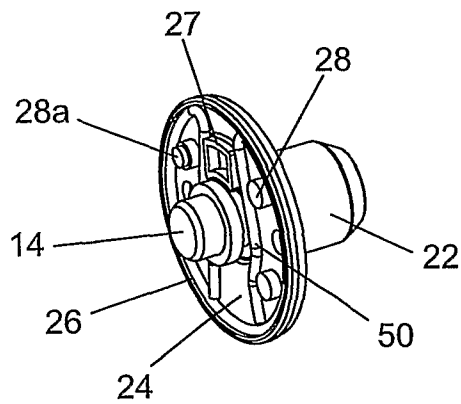

FIG. 5

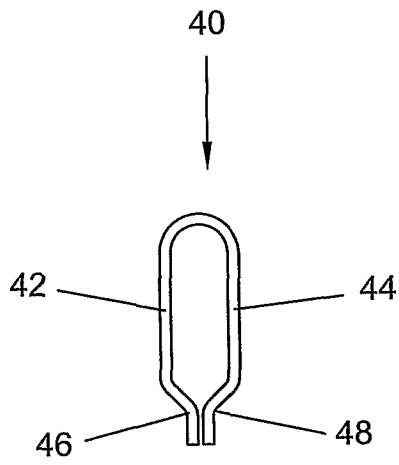

FIG. 6

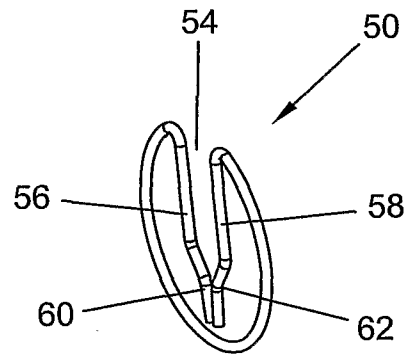

FIG. 7

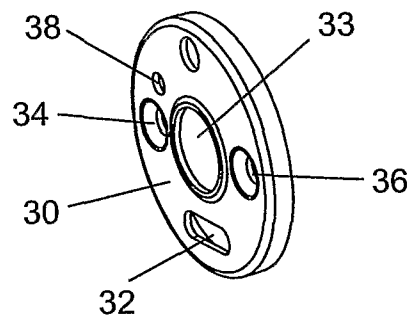

FIG. 8

INTERNATIONAL SEARCH REPORT

International application No.

PCT/NO2006/000419

A. CLASSIFICATION OF SUBJECT MATTER

IPC: see extra sheet

According to International Patent Classification (IPC) or to both national classification and IPC

B. FIELDS SEARCHED

Minimum documentation searched (classification system followed by classification symbols)

IPC: E05D

Documentation searched other than minimum documentation to the extent that such documents are included in the fields searched

SE,DK,FI,NO classes as above

Electronic data base consulted during the international search (name of data base and, where practicable, search terms used)

EPO-INTERNAL, WPI DATA, PAJ

C. DOCUMENTS CONSIDERED TO BE RELEVANT

Category*	Citation of document, with indication, where appropriate, of the relevant passages	Relevant to claim No.
A	WO 2006062412 A1 (INTROPIA AS), 15 June 2006 (15.06.2006) --	1-8
A	WO 2004013438 A1 (SECURISTYLE LIMITED), 12 February 2004 (12.02.2004) --	1-8
A	FR 2370845 A1 (SIEGENIA FRANK KG), 9 June 1978 (09.06.1978) -- -----	1-8

 Further documents are listed in the continuation of Box C. See patent family annex.

* Special categories of cited documents:

"A" document defining the general state of the art which is not considered to be of particular relevance

"E" earlier application or patent but published on or after the international filing date

"L" document which may throw doubts on priority claim(s) or which is cited to establish the publication date of another citation or other special reason (as specified)

"O" document referring to an oral disclosure, use, exhibition or other means

"P" document published prior to the international filing date but later than the priority date claimed

"T" later document published after the international filing date or priority date and not in conflict with the application but cited to understand the principle or theory underlying the invention

"X" document of particular relevance: the claimed invention cannot be considered novel or cannot be considered to involve an inventive step when the document is taken alone

"Y" document of particular relevance: the claimed invention cannot be considered to involve an inventive step when the document is combined with one or more other such documents, such combination being obvious to a person skilled in the art

"&" document member of the same patent family

Date of the actual completion of the international search

11 January 2007

Date of mailing of the international search report

11-01-2007

Name and mailing address of the ISA/

Swedish Patent Office

Box 5055, S-102 42 STOCKHOLM

Facsimile No. +46 8 666 02 86

Authorized officer

Christer Wendenius / MRo

Telephone No. +46 8 782 25 00

International patent classification (IPC)**E05D 15/40** (2006.01)**E05D 15/44** (2006.01)**E05D 7/10** (2006.01)**Download your patent documents at www.prv.se**

The cited patent documents can be downloaded at www.prv.se by following the links:

- In English/Searches and advisory services/Cited documents (service in English) or
- e-tjänster/anförda dokument (service in Swedish).

Use the application number as username.

The password is **QBPVIGUKFF**.

Paper copies can be ordered at a cost of 50 SEK per copy from PRV InterPat (telephone number 08-782 28 85).

Cited literature, if any, will be enclosed in paper form.

INTERNATIONAL SEARCH REPORT
Information on patent family members

25/11/2006

International application No.
PCT/NO2006/000419

WO	2006062412	A1	15/06/2006	NO	322000 B	31/07/2006
				NO	20045365 D	00/00/0000

WO	2004013438	A1	12/02/2004	AU	2003255708 A	00/00/0000
				GB	0217908 D	00/00/0000
				GB	0503444 D	00/00/0000
				GB	2391585 A	11/02/2004
				GB	2407340 A,B	27/04/2005
				US	20050262664 A	01/12/2005

FR	2370845	A1	09/06/1978	AT	364617 B	10/11/1981
				AT	722577 A	15/03/1981
				DE	7635460 U	24/02/1977
