

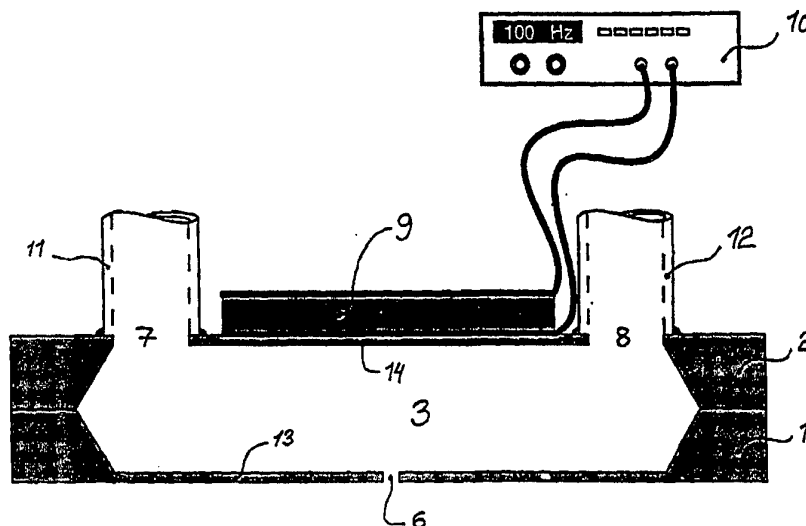

INTERNATIONAL APPLICATION PUBLISHED UNDER THE PATENT COOPERATION TREATY (PCT)

<p>(51) International Patent Classification ⁶ : G01N 1/10, 35/00</p>	<p>A1</p>	<p>(11) International Publication Number: WO 97/01085</p> <p>(43) International Publication Date: 9 January 1997 (09.01.97)</p>
<p>(21) International Application Number: PCT/SE96/00750</p> <p>(22) International Filing Date: 7 June 1996 (07.06.96)</p> <p>(30) Priority Data: 9502251-3 21 June 1995 (21.06.95) SE</p> <p>(71) Applicant (for all designated States except US): PHARMACIA AB [SE/SE]; S-171 97 Stockholm (SE).</p> <p>(72) Inventors; and (75) Inventors/Applicants (for US only): WALLMAN, Lars [SE/SE]; Värvädersgatan 6 A, S-222 27 Lund (SE). DROTT, Johan [SE/SE]; Södra Esplanaden 16 A, S-223 52 Lund (SE). NILSSON, Johan [SE/SE]; Jägaregatan 52, S-226 53 Lund (SE). LAURELL, Thomas [SE/SE]; Latinlinjen 9, S-224 73 Lund (SE). NILSSON, Staffan [SE/SE]; Siriusgatan 14, S-224 57 Lund (SE).</p> <p>(74) Agent: HEDENSTROM, John; Pharmacia AB, P.O. Box 941, S-251 09 Helsingborg (SE).</p>		<p>(81) Designated States: AL, AM, AT, AU, AZ, BB, BG, BR, BY, CA, CH, CN, CZ, DE, DK, EE, ES, FI, GB, GE, HU, IL, IS, JP, KE, KG, KP, KR, KZ, LK, LR, LS, LT, LU, LV, MD, MG, MK, MN, MW, MX, NO, NZ, PL, PT, RO, RU, SD, SE, SG, SI, SK, TJ, TM, TR, TT, UA, UG, US, UZ, VN, ARIPO patent (KE, LS, MW, SD, SZ, UG), Eurasian patent (AM, AZ, BY, KG, KZ, MD, RU, TJ, TM), European patent (AT, BE, CH, DE, DK, ES, FI, FR, GB, GR, IE, IT, LU, MC, NL, PT, SE), OAPI patent (BF, BJ, CF, CG, CI, CM, GA, GN, ML, MR, NE, SN, TD, TG).</p> <p>Published With international search report.</p>

(54) Title: FLOW-THROUGH SAMPLING CELL AND USE THEREOF



(57) Abstract

A sampling cell of flow-through type and use of such a sampling cell. The sampling cell is preferably manufactured by etching of silicon wafers. It is especially useful for continuous picovolume sampling in an analytical flow. The pressure pulse generating means (9) generate pressure pulses directly into a flow channel (3). The flow channel (3) is preferably formed by a first basin (4) in a first structure (1) and a second basin (5) in a second structure (2). In a first embodiment the pressure pulse generating means (9) comprise at least one piezo-ceramic disc and/or devices acting by way of magnetostrictive, electrostatical or electromechanical forces and/or devices acting by way of thermal expansion. Method of directing samples from a flow-through sampling cell and the object to which said samples are to be directed. Use of a flow-through sampling cell for coating of surfaces, especially for achieving biospecific surfaces, for extracting samples from a continuous liquid flow, for extracting a precise sample amount by collecting a defined number of samples or for injecting samples for electrophoresis, especially capillary electrophoresis, and for electrochromatography.

FOR THE PURPOSES OF INFORMATION ONLY

Codes used to identify States party to the PCT on the front pages of pamphlets publishing international applications under the PCT.

AM	Armenia	GB	United Kingdom	MW	Malawi
AT	Austria	GE	Georgia	MX	Mexico
AU	Australia	GN	Guinea	NE	Niger
BB	Barbados	GR	Greece	NL	Netherlands
BE	Belgium	HU	Hungary	NO	Norway
BF	Burkina Faso	IE	Ireland	NZ	New Zealand
BG	Bulgaria	IT	Italy	PL	Poland
BJ	Benin	JP	Japan	PT	Portugal
BR	Brazil	KE	Kenya	RO	Romania
BY	Belarus	KG	Kyrgyzstan	RU	Russian Federation
CA	Canada	KP	Democratic People's Republic of Korea	SD	Sudan
CF	Central African Republic	KR	Republic of Korea	SE	Sweden
CG	Congo	KZ	Kazakhstan	SG	Singapore
CH	Switzerland	LI	Liechtenstein	SI	Slovenia
CI	Côte d'Ivoire	LK	Sri Lanka	SK	Slovakia
CM	Cameroon	LR	Liberia	SN	Senegal
CN	China	LT	Lithuania	SZ	Swaziland
CS	Czechoslovakia	LU	Luxembourg	TD	Chad
CZ	Czech Republic	LV	Latvia	TG	Togo
DE	Germany	MC	Monaco	TJ	Tajikistan
DK	Denmark	MD	Republic of Moldova	TT	Trinidad and Tobago
EE	Estonia	MG	Madagascar	UA	Ukraine
ES	Spain	ML	Mali	UG	Uganda
FI	Finland	MN	Mongolia	US	United States of America
FR	France	MR	Mauritania	UZ	Uzbekistan
GA	Gabon			VN	Viet Nam

FLOW-THROUGH SAMPLING CELL AND USE THEREOF

This invention relates to a sampling cell of flow-through type, a method for directing samples from such a sampling cell and use of such a sampling cell. The sampling cell is preferably manufactured by etching of silicon wafers. It is especially useful for continuous picovolume sampling in an analytical flow or for picovolume deposition of specific chemicals.

Background and prior art

Micro sample extraction is useful in e.g. fraction determination from protein separation systems. The sample extraction and the fraction determination are tedious procedures, often including test tube matrix handling followed by analysis through e.g. gel electrophoresis before a final fraction identification is achieved.

Ref. 1 discloses a known sampling tool for fraction identification, being a flow-through cell comprising an orifice type nozzle and a piezo-ceramic disc glued onto a brass membrane. The brass membrane bends when a voltage is applied across the piezo-ceramic disc. The bending brass membrane creates a pressure pulse in a conical fluid-filled chamber which in turn transmits the pressure pulse onto a teflon membrane in the wall of the flow channel. Finally the pressure pulse, essentially unaffected, passes the teflon membrane and arrives in the fluid in the flow channel from which micro samples, i.e. small drops of the fluid, are ejected through the orifice type nozzle. This sampling tool is manufactured by conventional mechanical methods. This prior art sampling tool is schematically shown in the below Fig. 1 and 2.

Ref. 2 discloses an ink-drop generator comprising a piezo-ceramic layer generating a pressure pulse in a liquid-filled pressure channel. Anyhow this device is not of the flow-through type and can not be used for extracting samples from a continuous flow.

Advantages over prior art

The present invention relates to a sampling cell of flow-through type, i.e. a sampling cell with at least one flow inlet and at least one flow outlet from which samples are extracted from at least one sample emerging orifice, this orifice being separated from the flow inlet and the flow outlet. A sampling cell of flow-through type thus differs from other sampling cells, of non flow-through types, such as

those wherein the flow outlet also serves as sample emerging orifice.

The above described tool for micro sampling according to Ref. 1 has some disadvantages, such as transmission of the pressure pulse through an intermediate chamber and through two separate membranes, rather large dead volumes, risk for sticking of pressure pulse absorbing bubbles within the tool due to the hollow part adjacent the orifice type nozzle, low resonance frequency due to the large overall dimensions of the tool, adherence of liquid to the area around the exit side of the orifice type nozzle, need for separate filling of the conical fluid-filled chamber, need for regular exchange of the teflon membrane, requirements for tightening around the teflon membrane, and comparably complicated and expensive manufacturing.

US 5,338,688 (ROLF DEEG ET AL.) discloses a method for metered application of a biochemical analytical liquid to a target. Anyhow the device used is not of the flow-through type. Furthermore the method is limited to ejection of small liquid volumes through heating and subsequent evaporation of the liquid. Such heating may destroy the characteristics of the liquid.

US 3,775,058 (BRIAN BUSH) discloses method and apparatus for mixing liquids. Anyhow the apparatus used is not of the flow-through type. Furthermore the apparatus requires means for electrostatically charging droplets to be formed by the apparatus.

EP 119 573 A1 (MILES LABORATORIES, INC.) discloses microdroplet dispensing apparatus and method. Also in this reference the apparatus used is not of the flow-through type.

The sampling cell according to the present invention has inter alia the following advantages over prior art devices:

- the sample emerging orifice (6) is placed directly in the wall of the flow channel, which provides for a very smooth channel, thus minimizing the risk for sticking of pressure pulse absorbing bubbles within the cell;

- small dead volumes which implies small losses when changing the liquid in the flow channel (3), in turn being beneficial when expensive liquids to be analyzed are handled;

- bandbroadening due to dead volume is reduced;

- in the present silicon micro-machined sampling cell the pressure pulse is

generated directly on the walls of the flow channel while in prior art flow through cells, such as the cell according to Ref. 1, the actuating means act on a fluid chamber which in turn transmits the pressure pulse to the flow cell via a membrane;

5 - small drops are often required. With the present silicon based sampling cell smaller drops can be generated than with prior art sampling cells. This is due to the fact that smaller and more precise holes can be made by etching in silicon than in cells being manufactured with conventional mechanical methods;

10 - the sampling cell is preferably made entirely of silicon, which is a uniform, inert and biocompatible material being hydrophilic when oxidized;

 - the silicon parts may easily be chemically modified to adjust their surface properties.

Objects of the Invention

15 A first object of the present invention is a sampling cell without the above disadvantages in accordance with Claim 1.

 Further objects of the invention are different embodiments of the sampling cell of Claim 1.

 Still further objects of the invention are different uses of the sampling cell and a method of directing samples emerging from the sampling cell.

20 Short description of the figures

 The same figures, when denoted by reference signs, are in the description as well as in the drawings denoted by the same reference signs.

25 Fig. 1 shows in perspective a schematic view of a prior art micro sample tool in accordance with Ref. 1 in use for depositing microdrops of the eluate from an ion exchange column into an electrophoresis gel.

 Fig. 2 shows in cross-section a schematic side view of the prior art micro sample tool in accordance with Ref.1 and Fig.1.

30 Fig. 3 shows in perspective and partly in cross-section a schematic view of a first embodiment of a sampling cell according to the present invention comprising a first structure (1) and a second structure (2), here seen somewhat separated from each other, while being attached to one another when in use. In the first structure (1) is formed a first basin (4) and in the second structure (2) is formed a second

basin (5). The basins (4, 5) together form a flow channel (3). The first structure (1) has at least one sample emerging orifice (6). The second structure (2) has at least one flow inlet (7) and at least one flow outlet (8).

Figure 4 shows in cross section a schematic side view of the first embodiment of Fig. 3 with a pressure pulse generating piezo-ceramic disc (9) attached to a pulse generator (10), a first silicone tube (11) attached to the flow inlet (7) and a second silicone tube (12) attached to the flow outlet (8). The first basin (4) defines a first silicon membrane (13) in the first structure (1) and the second basin (5) defines a second silicon membrane (14) in the second structure (2).

Figures 5 and 6 are photographs showing ejection of drops, having a diameter of 40 μm , from the sample emerging orifice (6) of the first embodiment of the invention of the above Fig. 3 and 4.

Figure 7 shows in perspective and partly in cross-section an embodiment of the present invention in which the direction of the emerging samples is controlled in accordance with the below Example 2.

Detailed description of the invention

The following examples, with reference primarily to Fig. 3 - 7, are intended to illustrate but not to limit the scope of the invention.

Example 1

A sampling cell was manufactured from a first structure (1) and a second structure (2) which were fabricated on the same (100)-silicon wafer using anisotropic KOH etching. In the first structure (1) was formed a first basin (4), being 2 mm wide, 15 mm long and 350 μm deep. In the second structure was formed a second basin (5) having the same dimensions as the above first basin (4). In the first structure (1) was etched a sample emerging orifice (6) through the wafer approximately at the centre of the first basin (4). The sample emerging orifice (6) had a diameter of 60 μm and was in use serving as a sampling nozzle. In the second structure (2) was etched two holes, each having a diameter of 2 mm, through the silicon wafer at each end of the second basin (5), these holes serving as a flow inlet (7) and a flow outlet (8) respectively.

The respective thicknesses of a first (13) and a second (14) silicon membrane, through which the sample emerging orifice (6), the flow inlet (7) and the flow

outlet (8) were subsequently etched, were defined by a PN-etch stop process. The depth of the phosphorous doping thus defined the achieved thickness of the first (13) and the second (14) silicon membrane. The sample emerging orifice (6), the flow inlet (7) and the flow outlet (8) were formed by masking the corresponding areas of the first (13) and the second (14) silicon membrane.

Finally the first and second structures (1, 2) were bonded together by silicon direct bonding, whereby the first basin (4) and the second basin (5) together formed a flow channel (3). All angles within the flow channel (3) were made obtuse.

A first silicone tube (11) was glued with silicone rubber gel to the flow inlet (7) and a second silicone tube (12) was glued, also with silicon rubber gel, to the flow outlet (8) in order to provide simple flow connections. A piezo-ceramic disc (9), 8 mm wide and 0.2 mm thick, was glued onto the second silicon membrane (14) between the flow inlet (7) and the flow outlet (8).

The above sampling cell was operated in the following way:

A liquid flow was passed through the sampling cell and as the piezo-ceramic disc (9) was driven by 100 V pulses, 12 μ s duration at 1 - 100 Hz, generated by a pulse generator (10), a continuous drop train emerged from the sample emerging orifice (6). Fig. 5 and 6 show the drop ejection. The sample emerging orifice (6), having a diameter of 60 μ m, yielded a drop diameter of 40 μ m, i.e a drop volume of 34 pl. At a pulse frequency of 100 Hz this provided a sample flow of 0.2 μ l/min. The size of the drops may be controlled inter alia by the way the pressure pulse is generated.

The operational conditions can be summarized as follows:

The piezo-ceramic disc (9) and the second silicon membrane (14) to which it was glued together formed a bilaminar unit. When a voltage pulse was applied to the disc (9) a bending action was created. Such a bending action is known - see e.g. US patent 3,747,120 (STEMME). The pressure pulse thereby generated in the flow channel (3) caused a sample drop to be ejected from the sample emerging orifice (6).

Gas bubbles may be encountered in the liquid passing the flow channel (3). This happens e.g. in a liquid arriving from a chromatographic system due to the pressure gradient in the chromatograph column and the decreasing solubility of gas

in a liquid with increasing salt concentration. If gas bubbles enter the flow channel (3), the pressure generated by the piezo-ceramic disc (9) may be reduced which in turn may lead to a malfunctioning sampling cell. This phenomena is known from e.g. Ref. 3. To prevent gas bubbles from sticking to the inner walls of the flow channel (3) all angles formed by these inner walls were made to be obtuse. The bubble sticking tendency was further reduced by making the surface of the flow channel (3) non-adherent to gas bubbles through an oxidizing process. The passage of gas bubbles through the flow channel (3) was facilitated by operating the sampling cell in a vertical position with the flow inlet (7) below the flow outlet (8).

It was also important to prevent the outer surface around the sample emerging orifice (6) from being adhered to by the liquid in the flow channel (3), because liquid deposits in the vicinity of the sample emerging orifice (6) may cause drops to be misdirected during ejection. This phenomena is known from i.a. Ref. 2. This problem was solved by operating the sampling cell at a slight negative pressure and/or by making the area surrounding the sample emerging orifice (6) adherent towards the flow channel (3) and non-adherent on the exit side. Capillary forces thereby kept the liquid within the flow cell (3) the liquid meniscus being formed in the sample emerging orifice (6) thereby bending inwards.

Example 2

A sampling cell essentially in accordance with Example 1 was used in the following. A glass capillary for capillary electrophoresis was filled with a solution of sodium chloride (NaCl). Through a first end of the capillary was introduced a thin electrically conducting wire for contacting the solution. The second end of the capillary was placed close to the sampling cell, which was filled with ordinary tap water, and subsequently with a sodium chloride solution which did not alter the below described effects. The drop generation was initiated with a drop emerging frequency of around 50 Hz. A high voltage source was connected to the liquid in the sampling cell and to the wire in the first end of the glass capillary. A voltage of about 2500 V was used. When the voltage was applied the emerging drops were attracted by the second end of the glass capillary. The drops did hit the second end surface of the capillary and the outside of the capillary just below this second end surface. By allowing the liquid in the glass capillary to form a small volume

extending from the second end of the capillary a more precise hitting of the drops from the sampling cell was achieved. As the electrical force acting on the drops was fairly small it was difficult to influence the direction of the drops when they were close to the sample emerging orifice (6). A larger influence on the drops was achieved when the second end of the glass capillary was moved away some 10 mm from the sample emerging orifice (6) and slightly below this. In this case the velocity of the drops was already reduced and they had started to fall by their own weight.

Further embodiments

In Figs. 3, 4 and 6, showing embodiments of the present invention, the flow inlet (7) and the flow inlet (8) are placed on the same surface being opposite the sample emerging orifice (6). It is within the inventive concept to alter the positions of these parts. This means that the flow inlet (7) and the flow outlet (8) may well be placed on opposing surfaces. Likewise may the flow inlet (7) and/or the flow outlet (8) be placed on the same surface as the sample emerging orifice (6).

The actuating means may not be only a piezo-ceramic disc (9), but can also be means making use of e.g. magnetostrictive and/or electromechanical and/or electrostatic forces and/or thermal expansion. The actuating means may consist of one unit, as in Example 1, or a number of units. The actuating means may be placed not only opposite the sample emerging orifice (6), as in Example 1, but also adjacent other parts of the flow channel (3). It is even possible to place the actuating means on the same surface, i.e. corresponding to the first silicon membrane (13) in Example 1, as the sample emerging orifice (6). The flow-through sampling cell can be made entirely of a material which in itself is actuating, such as a piezo-ceramic material with the area around the sample emerging orifice (6) being made of an inert material such as silicon. In such an embodiment there is no need for separate actuating means, such as a piezo-ceramic disc (9) as the cell serves as its own actuator.

By appropriate choice of the geometrical dimensions of the sampling cell mechanical resonance can be reduced or amplified in order to achieve a certain effect on the drop generation. If e.g. the size of the sampling cell is reduced the resonance frequency is increased which leads to increased maximum drop emer-

ging frequency.

If the sampling cell has a fairly thin first silicon membrane (13) the pressure pulses will be dampened due to bending of this membrane (13). Often such dampening is unwanted as the drop generation is thereby disturbed. By making the sampling cell fairly stiff, i.a. by making the first silicon membrane (13) quite thick and thus less bendable, the dampening of the pressure pulse is reduced.

The sample emerging orifice (6) is placed directly in a wall of the flow cell (3), which provides for negligible amounts of liquid remaining in the sample emerging orifice (6) being an advantage e.g. when the sampling cell needs to be cleaned.

The area of adhesion between the liquid in the flow cell (3) during drop ejection and the exit surface of the sample emerging orifice (6) should be as small as possible in order to minimize disturbance on the drop generation. This can be achieved by attaching to the sample emerging orifice (6) a hollow protruding element, such as a short tube or nozzle, extending outwardly from the first silicon membrane (13). The hollow protruding element may also be fabricated directly in the material of the flow-through cell. The free end of such an element should preferably have a very thin or sharp edge, whereby the wetting around this end is minimized and thus also is minimized the disturbance on drop generation. The length of the protruding element should preferably be at least of the same size order as the diameter of the sample emerging orifice (6) in order to achieve a stable direction of the emerging drops. The diameter of the sample emerging orifice (6) can be freely varied up to around 100 μm . The minimum diameter of the the sample emerging orifice (6) is restricted by the clogging tendency of the fluid which should pass this orifice.

The outside of the sampling cell, especially in the vicinity of the sample emerging orifice (6), can be treated to avoid as much as possible adhesion of the liquid from the flow channel (3), e.g. by coating with an adhesion reducing material. The adhesion can be further reduced if the sample emerging orifice (6), and/or a possible prolonging tube, is provided with small channels or with a porous silicon coating in order to lead away the liquid.

In the above Examples 1 and 2 the sample emerging orifice (6) is placed

substantially opposite the piezo-ceramic disc (9) and in the centre of the first basin (4). The sample emerging orifice (6) may very well be placed elsewhere. Further may more than one sample emerging orifice (6) be established in order to achieve multiple trains of emerging drops.

5 Silicon is a very suitable material for the manufacturing of the present sampling cell. Anyhow other materials such as gallium arsenide, having attractive optical properties, or quartz, being in itself piezo-electrical and allowing UV transmission, may also be used. The known LIGA technique allows for micromaching with totally different materials, such as sintered ceramics, injection moulded polymers or pure
10 metal structures. The LIGA process allows fabrication of microstructures with high aspect ratios and great structural heights by synchrotron radiation lithography, galvanofarming and plastic moulding. See Ref. 4. PMMA (polymethyl methacrylate) can be used as phot resist for X-ray exposures. LIGA makes use of PMMA for deep lithography. Exposures as deep as several millimeters can be made. LIGA is
15 characterized by extremely high aspect ratios. The developed PMMA exposures may have a thickness of several millimeters with vertical surface roughness in the range of 0.1 μm . The developed PMMA-exposure can then be submitted to an electroplating procedure, yielding a "negative" metal mould. The metal mould can then be used as amaster to fabricate micro-structured devices with extreme aspect
20 ratios in mouldable materials. Very smooth cylindrical holes or tubes can be made to serve as sample emerging orifice (6) in the present flow-through sampling cell.

In the above Examples 1 and 2 the present sampling cell is essentially manufactured from two structures (1, 2). Within the inventive concept it is also possible to manufacture the sampling cell in many other ways, e.g. from three parts
25 - a first thin structure with inlet and outlet, a thick structure with a flow channel and a second thin structure with sample emerging orifice. It is also possible to manufacture the present sampling cell from one piece of material by micro-drilling.

Use of the invention

The sampling cell according to the present invention may i.e. be used
30 - for extracting small, often negligible, samples from a continuous liquid flow;
- for extracting a precise sample amount by collecting a defined number of sample drops each having a well-defined volume;

- for injecting samples for capillary electrophoresis or electrochromatography.

In this case the flow cell is filled with the test liquid and the emerging drops are directed towards the capillary. A suitable number of drops are directed towards the capillary end. The drops may be directed by the application of an electrical field
5 between the flow cell and the capillary opening. The samples can equally well be analyzed through other well known analytical methods, such as slab electrophoresis, mass spectrometry, chemical interaction analysis and liquid chromatography;

- for test sampling by splitting of the stream of sampling drops from e.g. liquid chromatography, flow injection analysis, fermentators or reactors to different
10 devices, for e.g. electrophoresis, liquid chromatography, flow injection analysis or chemical interaction analysis;

- for very exact drug delivery;

- for investigating the reaction velocity between different chemicals entering the flow channel (3) through separate flow inlets (7) and subsequently blending
15 within the flow channel (3);

- for simultaneous sampling from different parts of the flow channel (3), e.g. during blending of different chemicals using multiple sample emerging orifices (6);

- for evaluating the effects of injecting minute volumes of one liquid into a comparably large volume of another liquid by placing two sampling cells according
20 to the present invention very close to one another the sample emerging orifice (6) of the first cell facing the sample emerging orifice (6) of the second cell. If there is a slight negative pressure in the second cell samples ejected from the first cell are drawn into the liquid in the flow channel (3) of the second cell through its sample emerging orifice (6);

- for coating a surface with one or more material(s) in order to achieve a chemically active surface with specific characteristics;

- for dispensing different liquids, such as reaction solutions, preferably close to another, by using a multitude of flow-through sampling cells, preferably placed close together. Such dispensing may be simultaneous, consecutive or intermittent;

- as a printing device in an ink jet printer, e.g. for printing several colours
30 with just one nozzle by printing the respective colours in series consecutively changing the coloured ink in the flow channel.

References

- Ref. 1 Nilsson J, Szecsi P. and Schafer-Nielsen C.,
"A flow-through microsampling device applied to an ion exchange chroma-
• 5 tography system",
Journal of Biochemical and Biophysical Methods, 27, pp. 181-190, 1993.
- Ref. 2 Bentin, H., Doering, M., Radke, W. and Rothgordt, U.,
"Physical properties of micro-planar ink-drop generators",
10 J. Img. Techn. 12, pp. 152-155, 1986.
- Ref. 3 Brock, J.D., Cohen, I.M., Ivanov, I.P., Le, H.P. and Roy, J.,
"Oscillations of an air bubble in an ink jet",
15 J. Img. Techn. 10, pp. 127-129, 1984.
- Ref. 4 E.W. Becker, W. Ehrfeld, P. Hagmann, A. Mauer and D. Münchmeyer
Microelectronic Engineering 4 (1986) 35-36

CLAIMS

1. A flow-through sampling cell comprising pressure pulse generating means (9) and a flow channel (3) with at least one flow inlet (7), at least one flow outlet (8) and at least one sample emerging orifice (6), characterized in that the
5 pressure pulse generating means (9) generate pressure pulses directly into the flow channel (3).
2. A flow-through sampling cell according to claim 1, characterized in that it is manufactured by etching of silicon wafers.
3. A flow-through sampling cell according to claim 1, characterized
10 in that it is manufactured by etching or microstructuring of quartz, a piezo-electric material, preferably a piezo-ceramic ceramic, or gallium arsenide.
4. A flow-through sampling cell according to claim 1, characterized in that it is manufactured by LIGA technique yielding components in sintered
ceramics, injection moulded polymers and/or metals.
- 15 5. A flow-through sampling cell according to any one of the preceding claims, characterized in that the flow channel (3) is formed by a first basin (4) in a first structure (1) and a second basin (5) in a second structure (2).
6. A flow-through sampling cell according to any one of the preceding claims,
20 characterized in that it is designed to reduce the internal sticking of gas bubbles, preferably by having as many angles as possible within the flow channel (3) obtuse, preferably by giving the flow channel (3) a form without angles, such as a rounded form.
7. A flow-through sampling cell according to any one of the preceding claims,
25 characterized in that the pressure pulse generating means (9) comprise at least one piezo-ceramic element and/or devices acting by way of electromechanical, magnetostrictive or electrostatic forces and/or devices acting by way of thermal expansion.
8. A flow-through sampling cell according to any one of the preceding claims,
30 characterized in that the flow channel (3) is formed by the pressure pulse generating means (9).
9. A flow-through sampling cell according to any one of the preceding claims, characterized in that the pressure pulse generating means (9) are placed

opposite the at least one sample emerging orifice (6).

10. A flow-through sampling cell according to any one claims 1 - 8, characterized in that the pressure pulse generating means (9) are placed arbitrarily in relation to the at least one sample emerging orifice (6).

5 11. A flow-through sampling cell according to any one of the preceding claims, characterized in that the at least one sample emerging orifice (6) is attached a hollow protruding element, such as a short tube or a nozzle, or in that the at least one sampling orifice (6) is formed as a hollow protruding element.

10 12. A flow-through sampling cell according to claim 11, characterized in that the free part of the hollow protruding element ends with a sharp edge.

13. A flow-through sampling cell according to any one of the preceding claims, characterized in that the inside of the at least one sampling orifice (6) is treated to increase liquid adhesion and/or that the areas surrounding the at least one sampling orifice (6) are treated to decrease liquid adhesion, preferably by providing the at least one sampling orifice (3) and/or the short tube with small channels and/or with a porous silicon coating.

14. A flow-through sampling cell according to any one of the preceding claims, characterized in that the outside of the flow-through sampling cell is treated to reduce liquid adhesion.

20 15. A flow-through sampling cell according to any one of the preceding claims, characterized in that the flow-through sampling cell is designed to reduce dampening of the generated pressure pulses, preferably by making the flow-through sampling cell stiff.

25 16. A flow-through sampling cell according to any one of the preceding claims, characterized in that it further comprises means for controlling the direction of samples being ejected from the sample emerging orifice (6).

30 17. A flow-through sampling cell according to claim 16, characterized in that it comprises devices for establishing a difference in electrical potential between the liquid in the flow-through sampling cell and an object to which samples emerging from the flow-through cell are directed.

18. Method of directing samples from a flow-through sampling cell according to any one of the preceding claims, characterized in that a difference in

electrical potential is established between the liquid in the flow-through sampling cell and an object to which samples emerging from the flow-through cell are directed.

- 5 19. Use of a flow-through sampling cell according to any one of the preceding claims, c h a r a c t e r i z e d in that when the sampling cell is in use the at least one flow inlet (7) is below the at least one flow outlet (8)
20. Use of a flow-through sampling cell according to any one of the preceding claims for coating of surfaces, especially for achieving surfaces with specific chemical properties.
- 10 21. Use of a flow-through sampling cell according to any one of the preceding claims for extracting samples from a continuous liquid flow.
22. Use of a flow-through sampling cell according to any one of the preceding claims for extracting a precise sample amount by collecting a defined number of samples.
- 15 23. Use of a flow-through sampling cell according to any one of the preceding claims for injecting samples into devices for analysis, especially through capillary or slab electrophoresis, electrochromatography, mass spectrometry, chemical interaction analysis and chromatography.
- 20 24. Use of a flow-through sampling cell according to any one of the preceding claims for drug delivery.
- 25 25. Use of a flow-through sampling cell according to any one of the preceding claims for simultaneous sampling from different parts of the flow channel (3).
26. Use of a flow-through sampling cell according to any one of the preceding claims for investigating the reaction velocity between different chemicals entering the flow channel (3) through separate flow inlets (7) and subsequently blending within the flow channel (3);
27. Use of a flow-through sampling cell according to any one of the preceding claims in a printing device.
- 30 28. Use of a first and a second flow-through sampling cell according to any one of the preceding claims for receiving samples ejected from the sample emerging orifice (6) of the first cell at the sample emerging orifice (6) of the second cell.

29. Use of a multitude of flow-through sampling cells according to any one of the preceding claims, preferably being placed close to one another, for dispensing of different fluids, preferably into a small area.

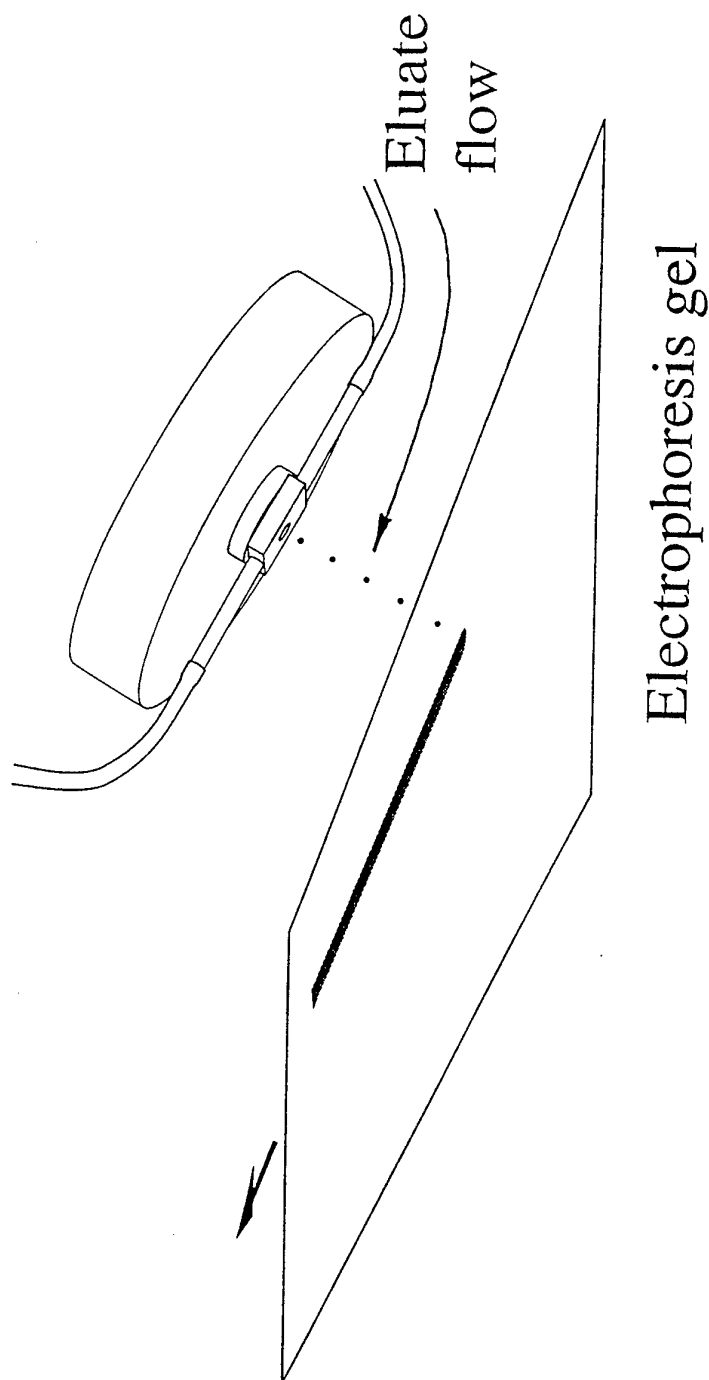

Fig. 7

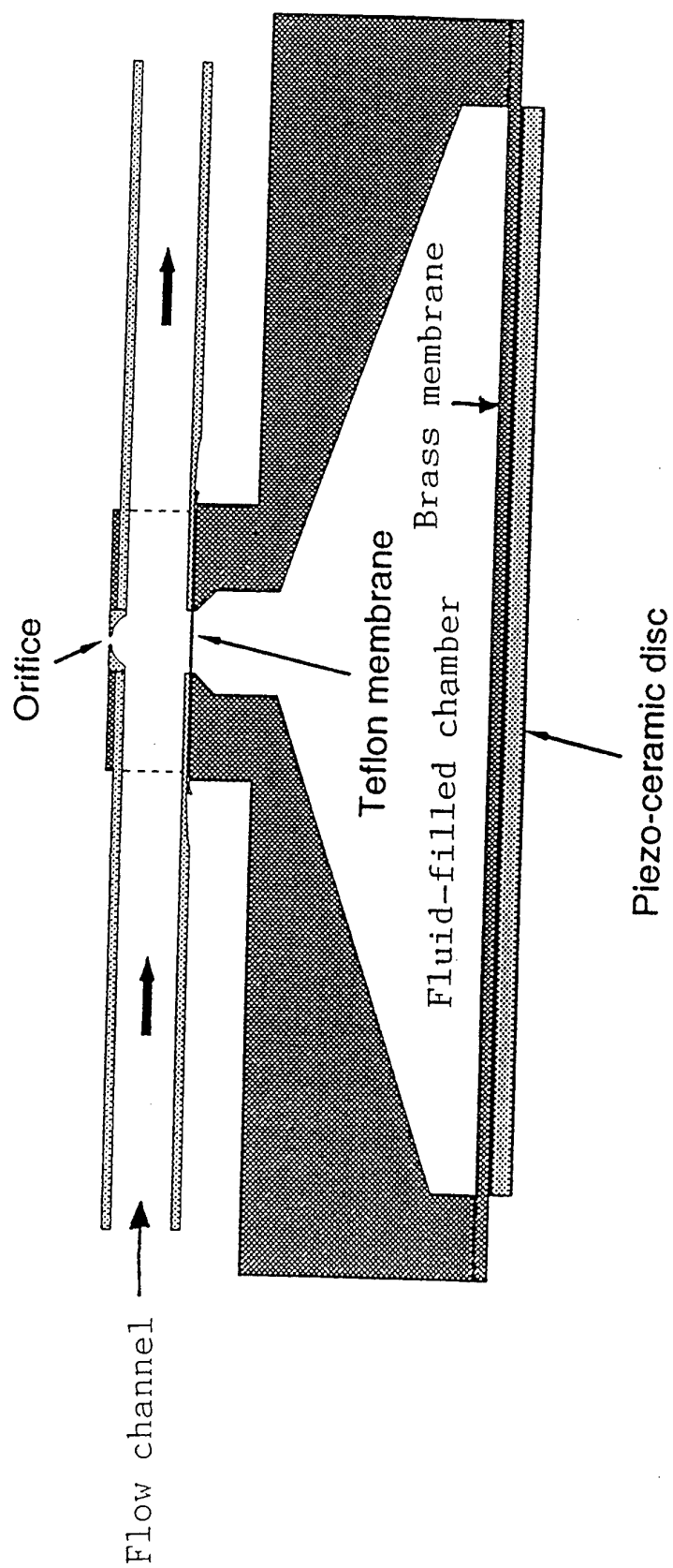

Fig. 2

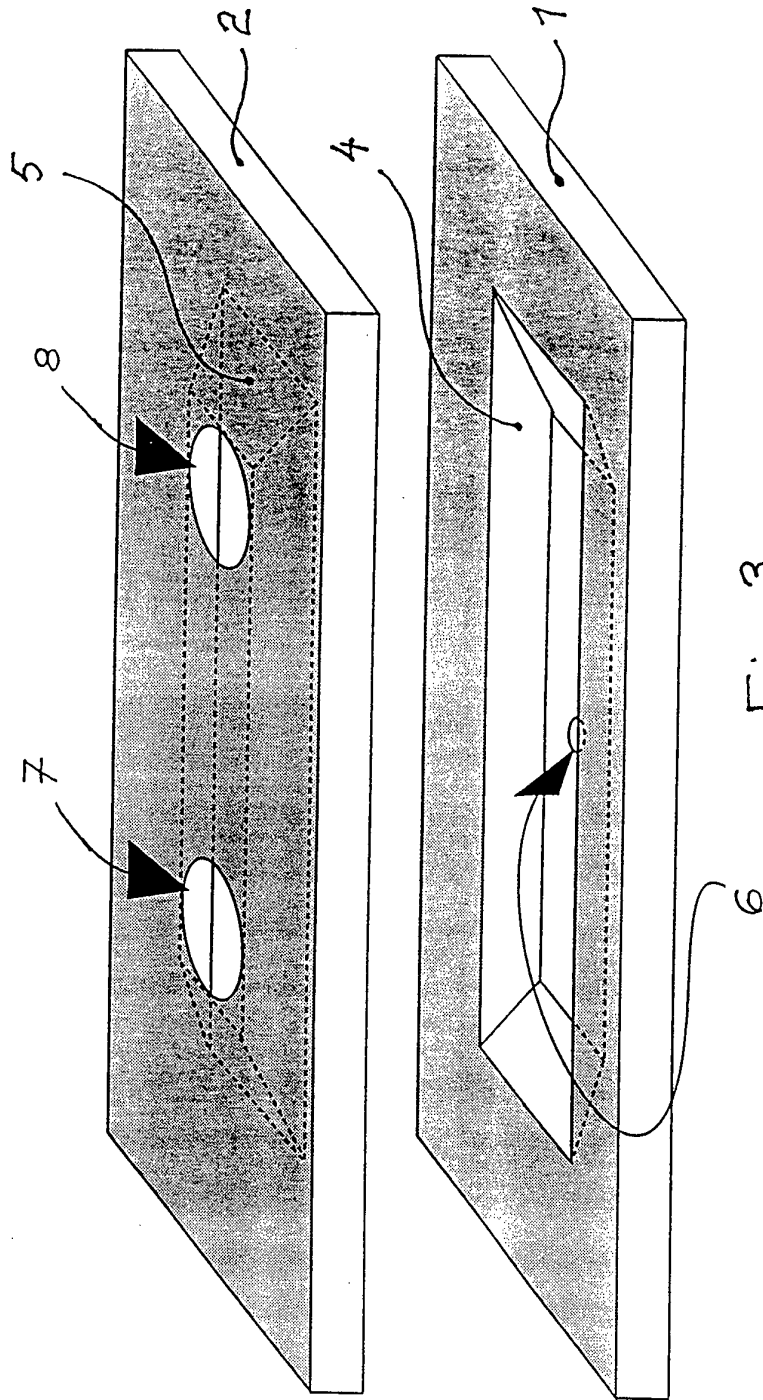

Fig. 3

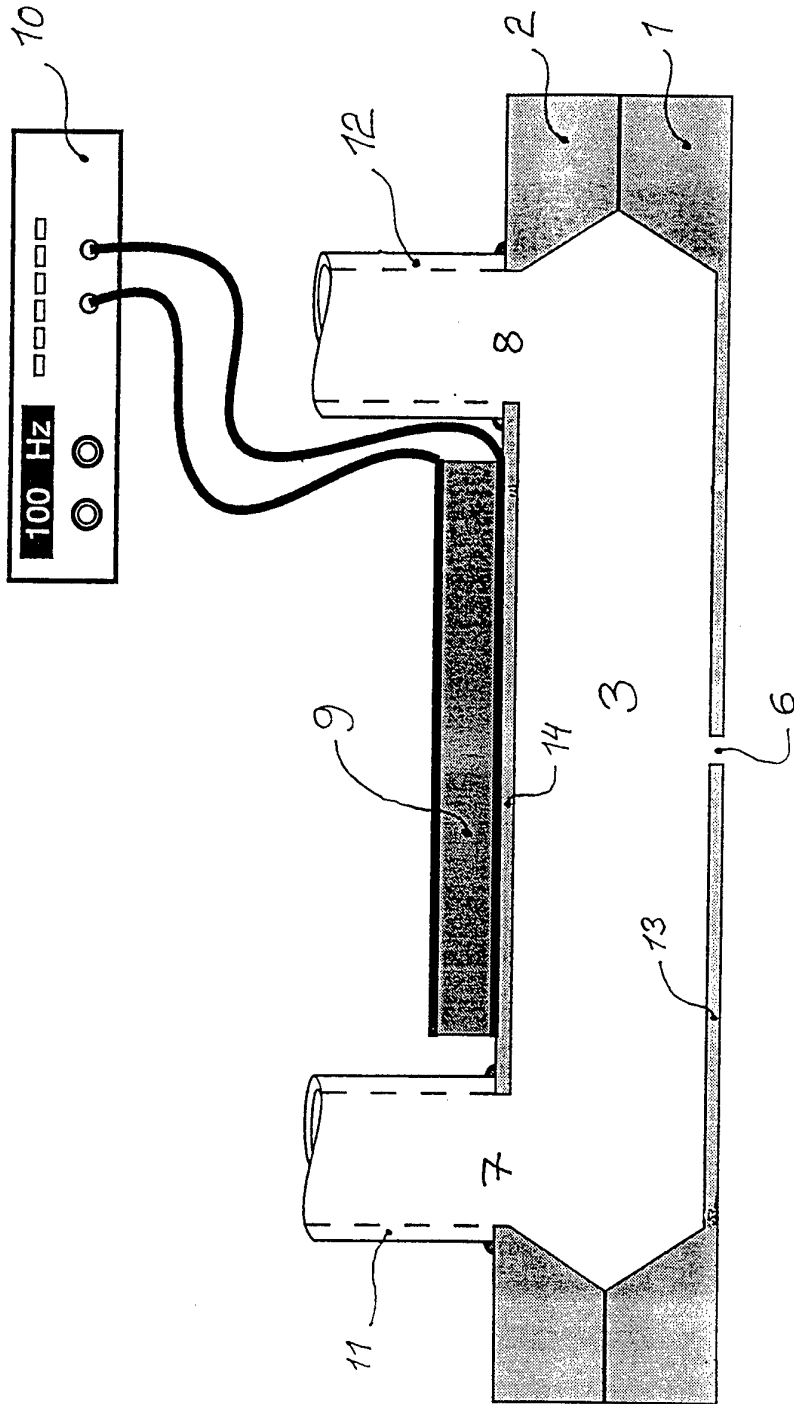

Fig 4

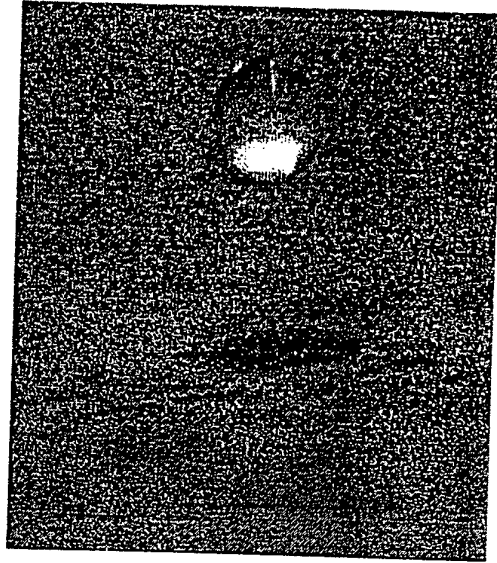

Fig. 6

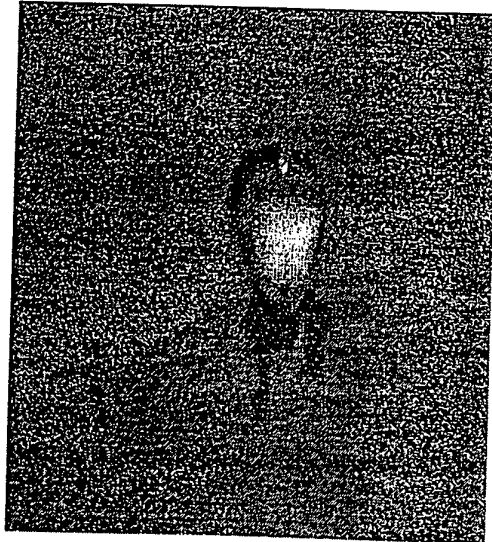

Fig. 5

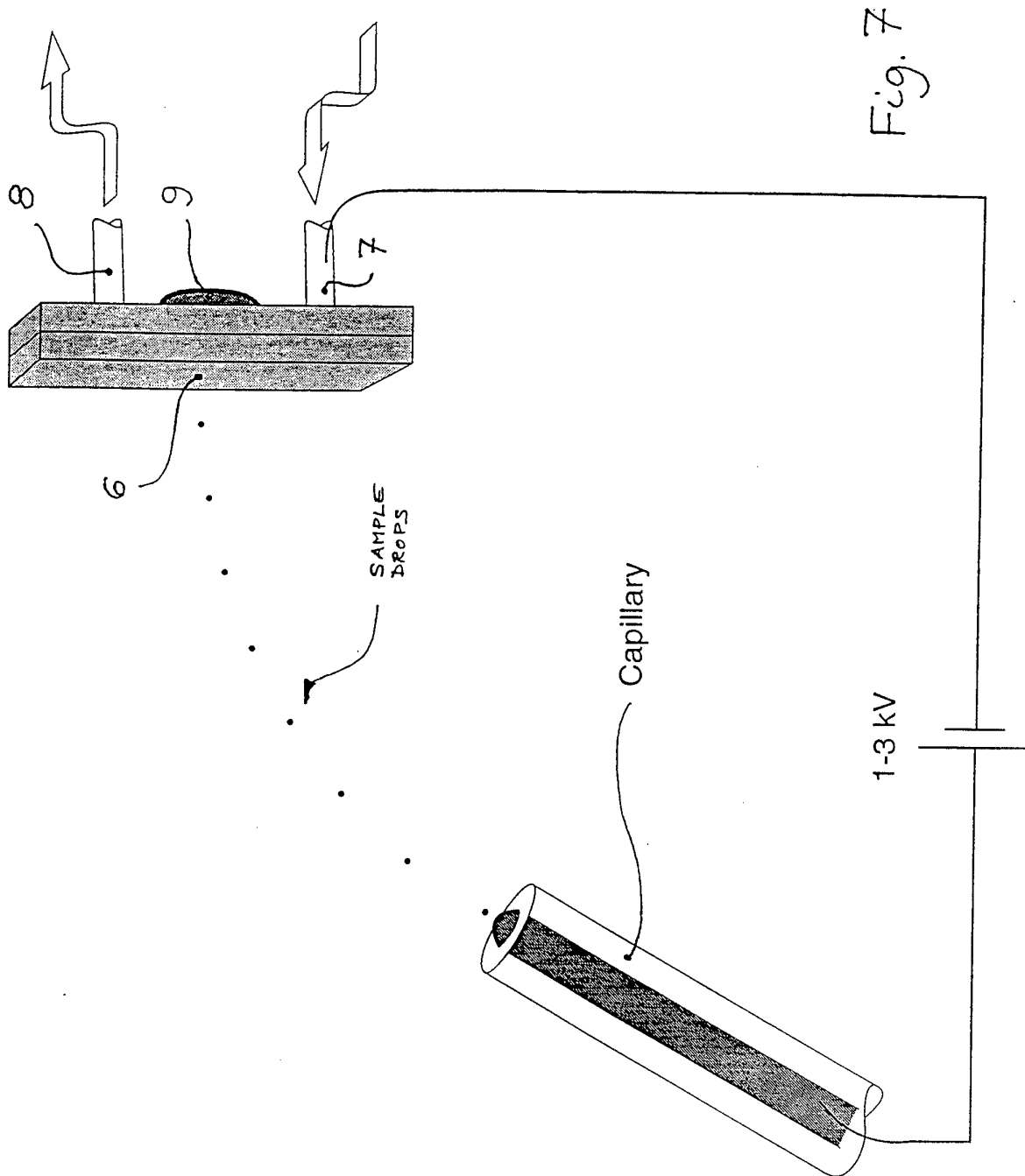

Fig. 7

INTERNATIONAL SEARCH REPORT

International application No.

PCT/SE 96/00750

A. CLASSIFICATION OF SUBJECT MATTER		
IPC6: G01N 1/10, G01N 35/00 According to International Patent Classification (IPC) or to both national classification and IPC		
B. FIELDS SEARCHED		
Minimum documentation searched (classification system followed by classification symbols)		
IPC6: G01N, G01F, B01L		
Documentation searched other than minimum documentation to the extent that such documents are included in the fields searched		
SE,DK,FI,NO classes as above		
Electronic data base consulted during the international search (name of data base and, where practicable, search terms used)		
C. DOCUMENTS CONSIDERED TO BE RELEVANT		
Category*	Citation of document, with indication, where appropriate, of the relevant passages	Relevant to claim No.
X	JOURNAL OF BIOCHEMICAL AND BIOPHYSICAL METHODS, Volume 27, 1993, Johan Nilsson et al, "A flow-through microsampling device applied to an ion-exchange chromatography system" page 181 - page 190 --	1,7,9,11, 16-20
Y	US 5338688 A (ROLF DEEG ET AL), 16 August 1994 (16.08.94), column 3, line 26 - line 43 --	1,7,9,19,20
Y	US 3775058 A (BRIAN BUSH), 27 November 1973 (27.11.73), column 4, line 39 - column 5, line 46 --	1,7,16-18
<input checked="" type="checkbox"/> Further documents are listed in the continuation of Box C. <input checked="" type="checkbox"/> See patent family annex.		
* Special categories of cited documents: "A" document defining the general state of the art which is not considered to be of particular relevance "E" earlier document but published on or after the international filing date "L" document which may throw doubts on priority claim(s) or which is cited to establish the publication date of another citation or other special reason (as specified) "O" document referring to an oral disclosure, use, exhibition or other means "P" document published prior to the international filing date but later than the priority date claimed "T" later document published after the international filing date or priority date and not in conflict with the application but cited to understand the principle or theory underlying the invention "X" document of particular relevance: the claimed invention cannot be considered novel or cannot be considered to involve an inventive step when the document is taken alone "Y" document of particular relevance: the claimed invention cannot be considered to involve an inventive step when the document is combined with one or more other such documents, such combination being obvious to a person skilled in the art "&" document member of the same patent family		
Date of the actual completion of the international search		Date of mailing of the international search report
8 October 1996		14 -10- 1996
Name and mailing address of the ISA/ Swedish Patent Office Box 5055, S-102 42 STOCKHOLM Facsimile No. +46 8 666 02 86		Authorized officer Ulla Granlund Telephone No. +46 8 782 25 00

INTERNATIONAL SEARCH REPORT

International application No.

PCT/SE 96/00750

C (Continuation). DOCUMENTS CONSIDERED TO BE RELEVANT

Category*	Citation of document, with indication, where appropriate, of the relevant passages	Relevant to claim No.
Y	EP 0119573 A1 (MILES LABORATORIES, INC.), 26 Sept 1984 (26.09.84), page 9, line 10 - page 11, line 17; page 18, line 10 - line 18 --	1,7,11
A	EP 0268237 A2 (ABBOTT LABORATORIES), 25 May 1988 (25.05.88), page 5, line 18 - line 22; page 6, line 20 - page 7, line 4 --	1,7,27
A	WO 9301485 A1 (GRASEBY DYNAMICS LIMITED), 21 January 1993 (21.01.93), page 9, line 15 - page 13, line 11 --	1,7,23
E	EP 0668500 A2 (FORSCHUNGSZENTRUM ROSSENDORF E.V.), 23 August 1995 (23.08.95), page 1, line 53 - page 2, line 22 -- -----	1,7

INTERNATIONAL SEARCH REPORT

Information on patent family members

05/09/96

International application No.

PCT/SE 96/00750

Patent document cited in search report	Publication date	Patent family member(s)	Publication date
US-A- 5338688	16/08/94	AU-B- 633446	28/01/93
		AU-A- 8116691	14/05/92
		CA-A- 2047636	03/02/92
		DE-A- 4024545	06/02/92
		EP-A- 0469444	05/02/92
		JP-B- 2524439	14/08/96
		JP-A- 4289457	14/10/92
US-A- 3775058	27/11/73	DE-A- 2110421	30/09/71
		FR-A- 2084570	17/12/71
		GB-A- 1346301	06/02/74
		NL-A- 7103370	15/09/71
		US-A- 3380584	00/00/00
EP-A1- 0119573	26/09/84	AU-A- 2519184	27/09/84
		JP-A- 59188539	25/10/84
EP-A2- 0268237	25/05/88	AT-T- 112849	15/10/94
		AU-B- 603617	22/11/90
		AU-A- 8120787	19/05/88
		CA-A- 1308467	06/10/92
		DE-D, T- 3750655	11/05/95
		JP-B- 7006975	30/01/95
		JP-A- 63139253	11/06/88
		US-A- 4877745	31/10/89
WO-A1- 9301485	21/01/93	CA-A- 2112910	21/01/93
		EP-A- 0594719	04/05/94
		JP-T- 6509170	13/10/94
EP-A2- 0668500	23/08/95	DE-A- 4405004	24/08/95