



US 20050204464A1

(19) **United States**

(12) **Patent Application Publication**

Dotson

(10) **Pub. No.: US 2005/0204464 A1**

(43) **Pub. Date: Sep. 22, 2005**

(54) **DEVICE AND METHOD FOR MAINTAINING SWIMMING POOLS**

Publication Classification

(76) **Inventor: Christopher B. Dotson**, Middletown, CT (US)

(51) **Int. Cl.⁷ E04H 4/00**

(52) **U.S. Cl. 4/496**

Correspondence Address:

**MCCORMICK, PAULDING & HUBER LLP
CITY PLACE II
185 ASYLUM STREET
HARTFORD, CT 06103 (US)**

(57) **ABSTRACT**

A device for winterizing pools comprises a compartment including a front portion having a periphery defining a first opening. An upper portion of the compartment defines a second opening. The periphery is to sealingly engage a wall of a swimming pool such that the first opening surrounds a return line aperture defined by the wall of the swimming pool. The second opening defined by the upper portion is to be disposed above a water level of the swimming pool. A pump is to be disposed within the compartment, and is energized by, for example, a DC power supply. A conduit includes a first end to be coupled to an outlet of the pump and includes a second end to be disposed outside of the compartment and adjacent to the upper portion thereof for directing fluid out of the compartment.

(21) **Appl. No.: 11/065,374**

(22) **Filed: Feb. 24, 2005**

Related U.S. Application Data

(60) **Provisional application No. 60/548,807**, filed on Feb. 27, 2004.

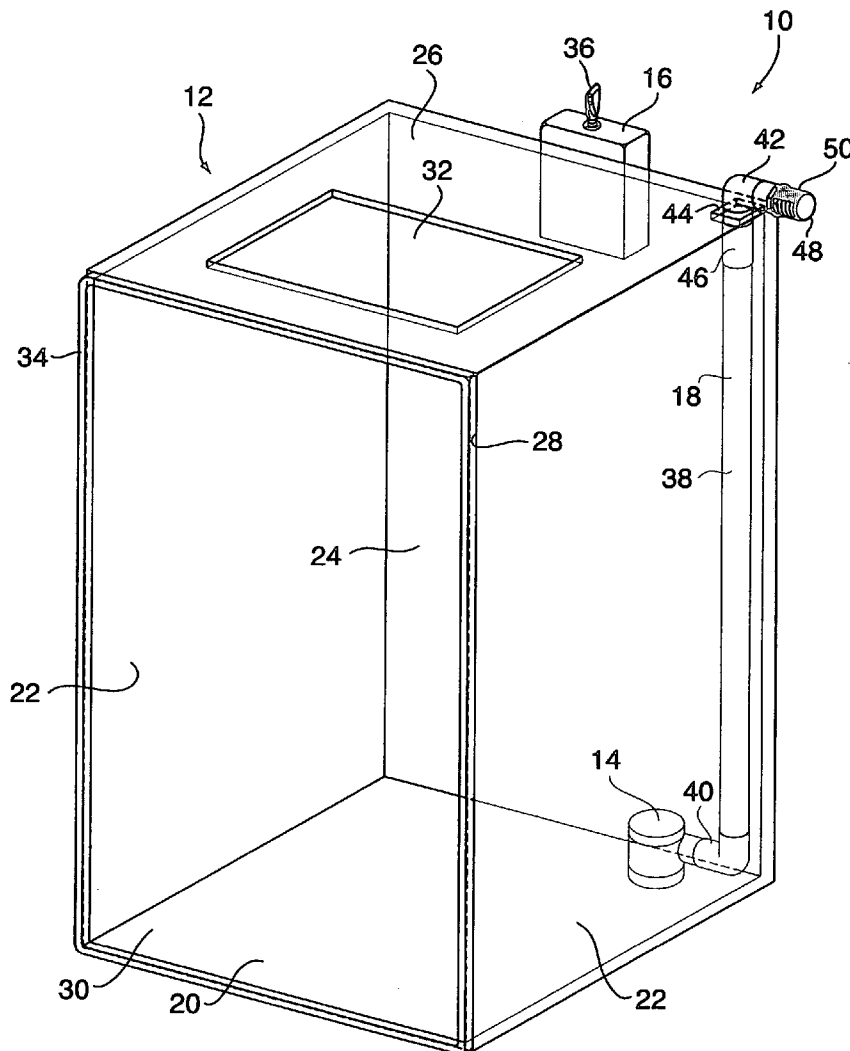

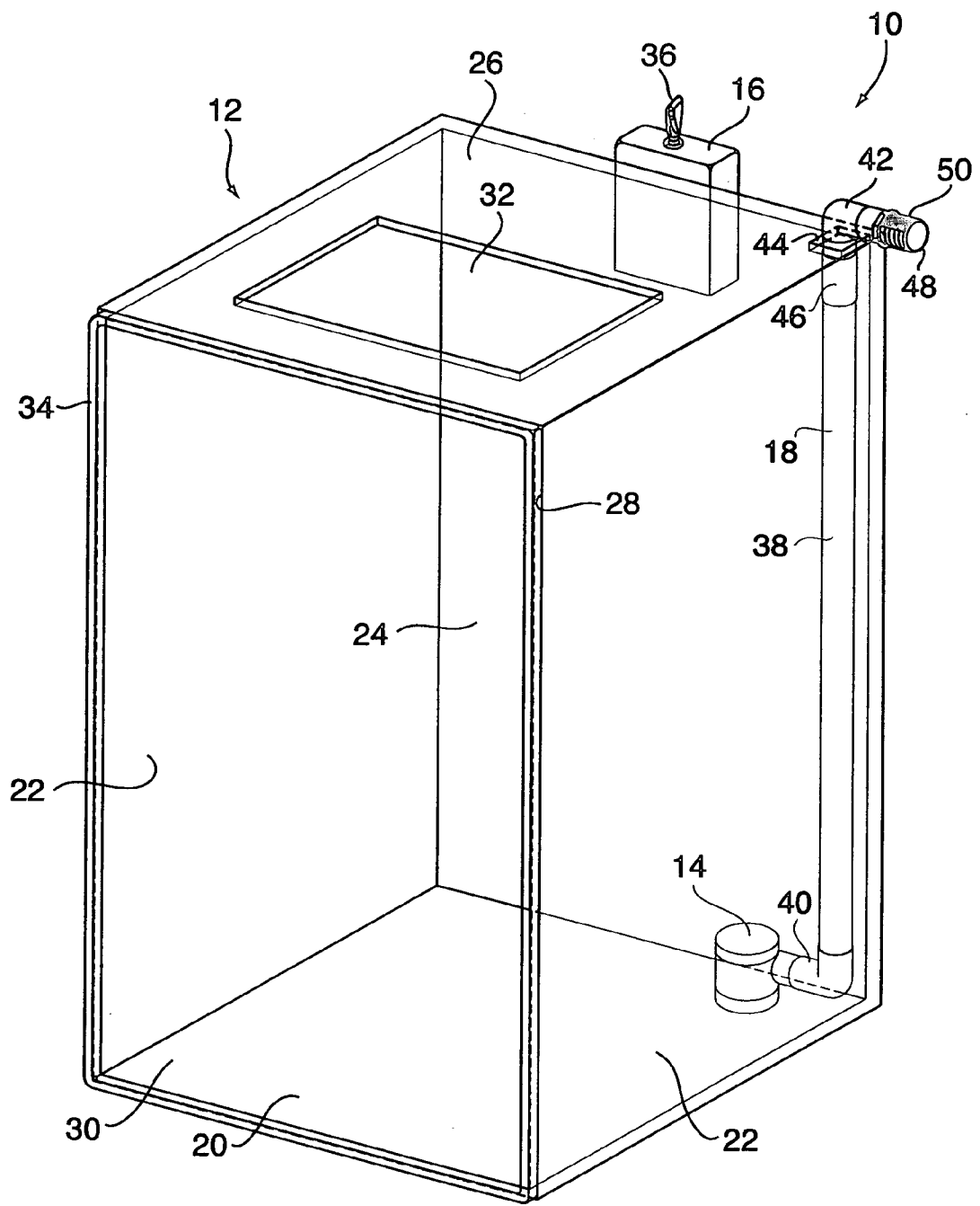

FIG. 1

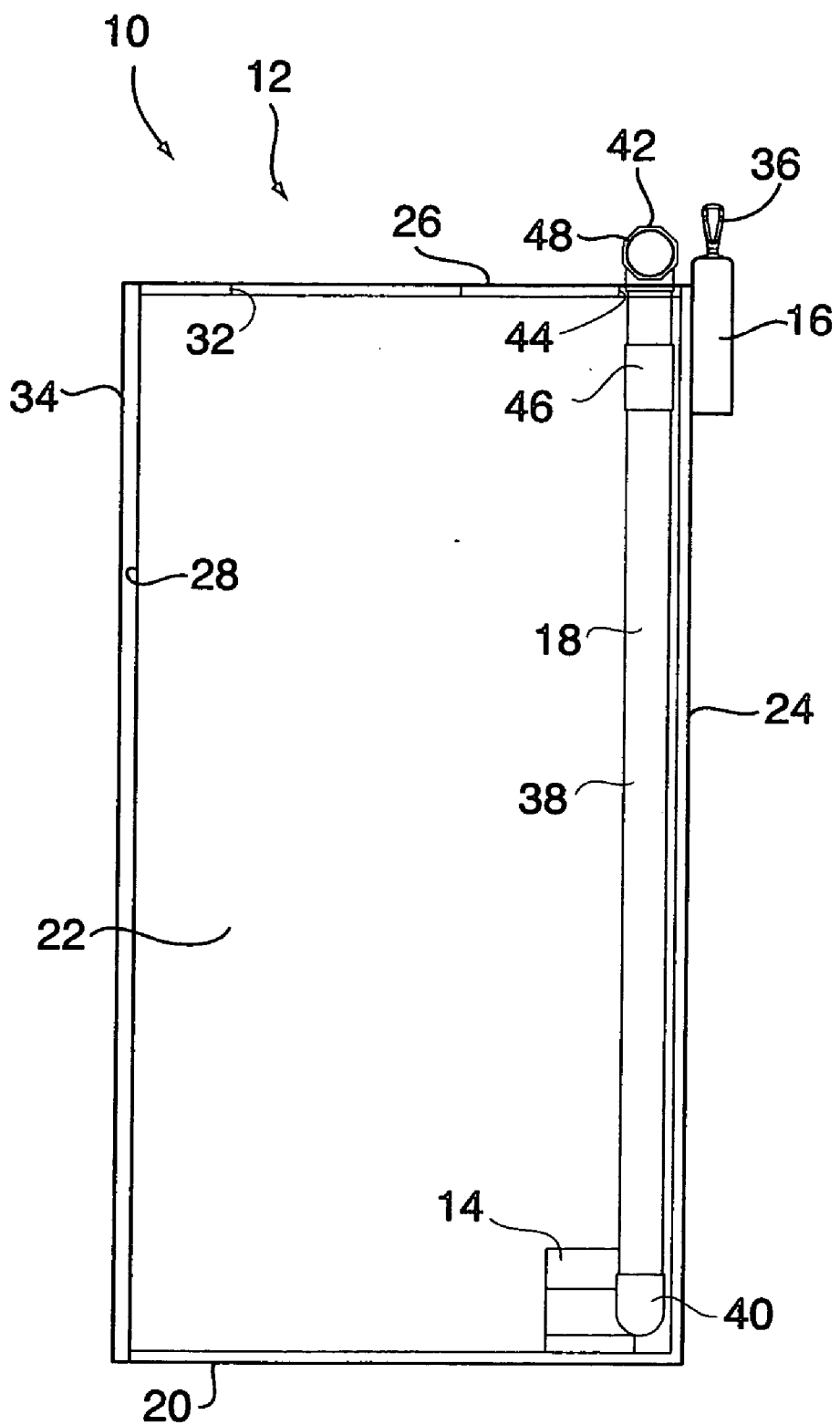

FIG. 2

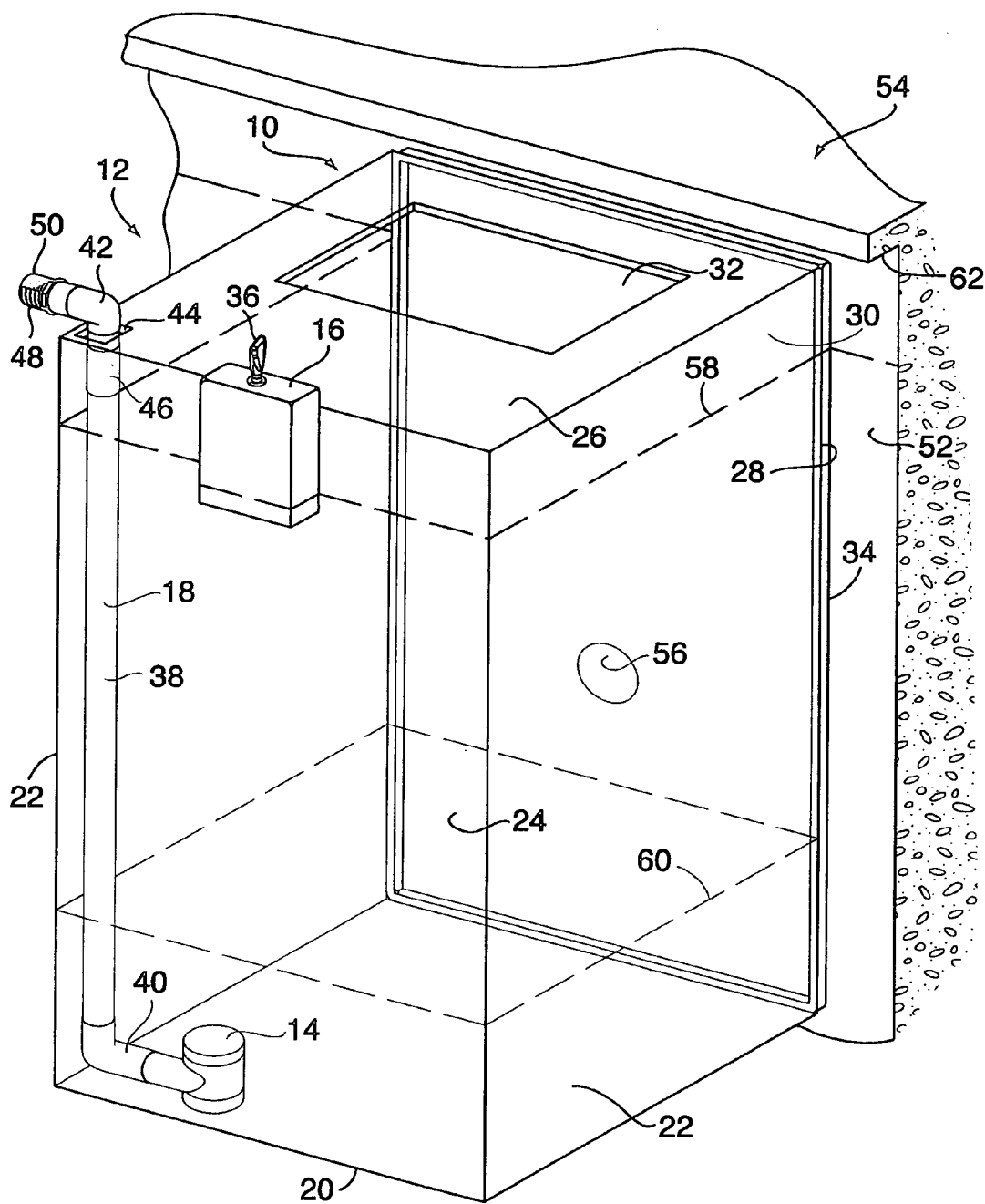

FIG. 3

DEVICE AND METHOD FOR MAINTAINING SWIMMING POOLS

CROSS-REFERENCE TO RELATED APPLICATION

[0001] This application claims the benefit of U.S. Provisional Application No. 60/548,807, filed on Feb. 27, 2004, the disclosure of which is herein incorporated by reference in its entirety.

FIELD OF THE INVENTION

[0002] The present invention is generally directed to a device and method for maintaining swimming pools, and more particularly relates to a device and method for winterizing inground swimming pools.

BACKGROUND OF THE INVENTION

[0003] Winterizing inground swimming pools can include draining water from the return lines and thereafter filling the return lines with a winterizing chemical fluid such as anti-freeze. This process prevents water in the return lines from expanding as a result of freezing, and thereby damaging the return lines. Winterizing the return lines is typically wasteful of water and is time consuming. Winterizing the return lines typically involves draining water in a swimming pool below the return lines to treat 5,000 to 10,000 gallons of water. This is a substantial waste of water. Moreover, the process of draining water can last as long as five hours.

[0004] Based on the foregoing, it is an object of the present invention to provide a device and method for winterizing a pool that overcomes the above-mentioned drawbacks and disadvantages.

SUMMARY OF THE INVENTION

[0005] In a first aspect of the present invention, a device for winterizing pools comprises a compartment including a front portion having a periphery defining a first opening. An upper portion of the compartment defines a second opening. The periphery is for sealingly engaging a wall of a swimming pool such that the first opening surrounds a return line aperture defined by the wall of the swimming pool. The second opening defined by the upper portion is to be disposed above a water level of the swimming pool. A pump is to be disposed within the compartment, and is energized by, for example, a DC power supply. A conduit includes a first end to be coupled to an outlet of the pump and includes a second end to be disposed outside of the compartment and adjacent to the upper portion thereof for directing fluid out of the compartment.

[0006] In a second aspect of the present invention, a method of winterizing swimming pools comprises providing a compartment including a front portion having a periphery defining a first opening, and an upper portion defining a second opening. A pump is disposed within the compartment. A conduit includes a first end coupled to an outlet of the pump and includes a second end disposed outside of the compartment and adjacent to the upper portion thereof. The periphery of the compartment is placed against a wall of a swimming pool such that the first opening surrounds a return line aperture defined by the wall of the swimming pool, and the second opening is positioned above a water level of the swimming pool. The pump is energized to create a vacuum

to sealingly engage the periphery against the wall of the swimming pool, and to direct fluid through the conduit and out of the compartment until the fluid level within the compartment is at least below that of the return line aperture.

BRIEF DESCRIPTION OF THE DRAWINGS

[0007] FIG. 1 is a perspective view of a device for winterizing swimming pools embodying the present invention.

[0008] FIG. 2 is a side view of the device of FIG. 1.

[0009] FIG. 3 is a perspective view of the device of FIG. 1 employed in a swimming pool.

[0010] FIG. 4 is a side view of the device of FIG. 1 employed in a swimming pool.

DETAILED DESCRIPTION OF THE PREFERRED EMBODIMENT

[0011] With reference to FIGS. 1-4, a device for winterizing swimming pools is indicated generally by the reference number 10. The device 10 should be used in climates where there is the possibility of the outdoor temperature falling below the freezing temperature of water. The device comprises a compartment 12, a pump 14 disposed in the compartment for evacuating fluid from the compartment, a power supply 16 for energizing the pump, and a conduit 18 coupled to the pump for directing fluid out of the compartment.

[0012] In a preferred embodiment, the compartment 12 is rectangular and includes a bottom wall 20, two sidewalls 22, a rear wall 24, and an upper wall 26. Front edges of the bottom wall 20, the sidewalls 22, the rear wall 24, and the upper wall 26 cooperate to form a periphery 28 defining an open front face or first opening 30. The upper wall 26 of the compartment 12 defines a second opening 32. The compartment 12 is fabricated from a hard plastic or other strong material that maintains its shape under water pressure.

[0013] By way of example only, the dimensions of the compartment 12 are: length of about 14 inches, width of about 12 inches, and height of about 24 inches. The dimensions of the second opening 32 can be: length of about 9 inches, and width of about 5 inches so as to be large enough for an operator's hand or arm to enter therethrough in order to access the pump 14 or a return line of a swimming pool to be enclosed by the open front face 30 of the compartment 12 as is explained more fully below. The second opening 32 can be disposed about 2 inches from the open front face 30 of the compartment 12, and about 5 inches from the rear wall 24 of the compartment. The walls of the compartment 12 are preferably at least ¼ inch thick. Although the compartment 12 is rectangular in a preferred embodiment, the compartment can take other practical shapes without departing from the scope of the present invention.

[0014] As shown in FIG. 1, the periphery 28 includes a resilient, compressible gasket or seal 34 disposed thereon for creating a generally watertight and waterproof seal around the open front face 30 of the compartment 12. In a preferred embodiment, the seal 34 is a resilient polyethylenepropylene (EPDM) self-adhesive weatherstrip tape manufactured by Macklanburg-Duncan Co. of Oklahoma City, Okla. The weather strip has a D-profile and is 23/64 inch wide and

$\frac{5}{16}$ inch thick. However, the seal **34** can be fabricated from other generally watertight materials.

[0015] The pump **14** is mounted within the compartment **12** at a rear lower corner thereof. Preferably, the pump **14** is a submersible bilge pump such as, for example, the Rule 360 Non-Automatic Bilge Pump manufactured by Rule Industries, Inc. of Burlington, Mass. The Rule 360. Pump has a capacity of 360 gallons per hour (1363 liters per hour), and operates on 12 volts DC. The pump **14** can have a higher or lower capacity depending on the size of the compartment **12** to be evacuated.

[0016] The power supply **16** includes a generally watertight housing accommodating a DC battery source such as, for example, eight AAA 1.5 volt dry cell batteries electrically coupled in series. The power supply **16** preferably includes an on/off switch **36** mounted on top of the housing for turning the pump **14** on and off. The DC current generated by the power supply **16** will not shock a user if the dry cell batteries get wet and will generally not short out.

[0017] The conduit **18**, preferably a plastic hose or PVC pipe, includes a longitudinal portion **38** such as, for example, a $\frac{1}{2}$ inch or $\frac{3}{4}$ inch section vertically disposed along a rear corner or seam of the compartment **12**. The longitudinal portion **38** of the conduit **12** has a first end **40** in the form of a 90 degree or elbow section coupled to an outlet of the pump **14**, and a second end **42** in the form of a 90 degree or elbow section disposed outside of the compartment **12** and adjacent to an upper portion thereof for directing fluid out of the compartment. Pump wires (not shown) preferably extend behind the conduit **18** from the power supply **16** to the pump **14**. An upper portion of the conduit **18** extends through a third opening **44** defined by the upper wall **26** of the compartment **12** such that the second end **42** of the conduit is disposed outside of and above the upper wall. The longitudinal portion **38** preferably includes a 360 degree swivel section **46** disposed adjacent to the second end **42** to permit adjustment of the orientation of an outlet **48** of the second end and to thereby direct pumped water back into a swimming pool. Moreover, the second end **42** defines attachment threads **50** for connecting the conduit **18** to, for example, a hose fitting for the recapture and possible reuse of winterizing chemical fluids or antifreeze as is explained more fully below.

[0018] In operation, the open front face or first opening **30** of the compartment **12** is placed over and flush against a wall **52** of a swimming pool **54** such that the first opening surrounds a return line **56** defined by the wall of the swimming pool, and such that the second opening **32** defined by the upper wall **26** of the compartment is disposed above a water level **58** of the pool. The pump **14** is then energized by the power supply **16** to draw water out of the compartment **12** via the conduit **18** and back into the pool **54**. The second opening **32** disposed above the water level **58** of the swimming pool **54** permits air to fill the vacuum generated within the compartment **12** as fluid is being evacuated therefrom. The compartment **12** is held against the wall **52** to start suction. As water is drawn out of the compartment **12**, a localized water level **60** within the compartment is lowered at least below that of the return line **56** enclosed by the compartment.

[0019] Preferably, water is totally evacuated from the compartment **12**. As water is being evacuated, the water

pressure outside the compartment **12** becomes greater than the pressure inside the compartment to further compress the seal **34** against the wall **52** of the swimming pool **54** and thereby prevent water from leaking back into the compartment. Sometimes the difference in pressure between the inside and outside of the compartment **12** is large enough to force the compartment upward. However, such upward movement of the compartment **12** is eventually halted once the compartment contacts an overhang **62** of the swimming pool **54**. The user can then reach through the second opening **32** to access the return line **56**. The return line **56** is blown out and excess water in the line can be drawn by the pump **14** out of the compartment **12** and back into the swimming pool **54**. The return line **56** can then be replaced with a winterizing chemical fluid or non-toxic antifreeze and the return line thereafter capped for the winter with no water remaining inside the return line. The device **10** can also be used in the spring or summer to pump the winterizing chemical fluid out of the return line **56** as explained below.

[0020] The device **10** saves water from being wasted during the winterizing process by pumping back into a pool approximately five to ten gallons of water. Moreover, the winterizing process using the device **10** takes only approximately five minutes. Conventionally, water would be drained below the return lines to winterize 5,000 to 10,000 gallons of water, chemicals would have to go into the sewer systems, and it would take upwards of five hours to drain.

[0021] Winterizing chemical recapture in the spring in accordance with the present invention is also possible by placing the compartment **12** over the return line **56** and evacuating water from the compartment **12** in a way similar to that explained above with respect to winterizing a pool. The return line **56** is then uncapped and the winterizing chemical fluid is drained into the compartment **12** and evacuated by the pump **14** therefrom via the conduit **18**. A hose (not shown) can be attached to the threads **50** of the second end **42** of the conduit **18** to recapture the winterizing chemical fluid, or alternatively an antifreeze bottle or other container can be held under the second end of the conduit in order to fill the container. The recaptured winterizing chemical fluid would need to be tested in the fall for strength or dilution before reusing.

[0022] While the present invention has been described in a preferred embodiment, it will be understood that numerous modifications and substitutions can be made without departing from the spirit of the invention. Accordingly, the present invention has been described in a preferred embodiment by way of illustration, rather than limitation.

What is claimed is:

1. A device for winterizing pools, comprising:
 - a compartment including a front portion having a periphery defining a first opening, and an upper portion defining a second opening, the periphery to sealingly engage a wall of a swimming pool such that the first opening surrounds a return line aperture defined by the wall of the swimming pool, the second opening defined by the upper portion to be disposed above a water level of the swimming pool;
 - a pump to be disposed within the compartment; and
 - a conduit including a first end to be coupled to an outlet of the pump and including a second end to be disposed

- outside of the compartment and adjacent to the upper portion thereof for directing fluid out of the compartment.
- 2. A device as defined in claim 1, further comprising a power supply to communicate with and energize the pump.
- 3. A device as defined in claim 2, wherein the power supply includes a DC battery source.
- 4. A device as defined in claim 2, wherein the power supply includes an on/off switch to respectively energize and de-energize the pump.
- 5. A device as defined in claim 1, further including a seal to be disposed on the periphery of the first opening.
- 6. A device as defined in claim 5, wherein the seal includes a resilient material for forming a generally watertight seal.
- 7. A device as defined in claim 5, wherein the seal includes a polyethylenepropylenediene weatherstrip tape for forming a generally watertight seal.
- 8. A device as defined in claim 1, wherein the pump is a submersible bilge pump.
- 9. A device as defined in claim 1, wherein the compartment is generally rectangular.
- 10. A device as defined in claim 9, wherein the compartment includes a bottom wall, two sidewalls, a rear wall, an upper wall defining the second opening, and wherein front edges of the bottom wall, the sidewalls and the upper wall forming the periphery of the first opening.
- 11. A device as defined in claim 1, wherein the second end of the conduit includes an elbow section to direct fluid away from the compartment.
- 12. A device as defined in claim 11, wherein the elbow section defines attachment threads.
- 13. A device as defined in claim 11, wherein the conduit includes a swivel section for adjusting an orientation of the elbow section.
- 14. A method of winterizing swimming pools, comprising the steps of:

- providing a compartment including a front portion having a periphery defining a first opening, and an upper portion defining a second opening;
- providing a pump disposed within the compartment;
- providing a conduit including a first end coupled to an outlet of the pump and including a second end disposed outside of the compartment and adjacent to the upper portion thereof;
- placing the periphery against a wall of a swimming pool such that the first opening surrounds a return line aperture defined by the wall of the swimming pool, and positioning the second opening above a water level of the swimming pool; and
- energizing the pump to create a vacuum to sealingly engage the periphery against the wall of the swimming pool, and to direct fluid through the conduit and out of the compartment until a fluid level within the compartment is at least below that of the return line aperture.
- 15. A method as defined in claim 14, further including the steps of:
 - draining water from the return line aperture;
 - inserting a winterizing chemical fluid into the return line aperture; and
 - closing the return line aperture.
- 16. A method as defined in claim 14, further including the steps of:
 - opening the return line aperture;
 - draining a winterizing chemical fluid from the return line aperture and into the compartment; and
 - energizing the pump to draw the winterizing chemical fluid out of the compartment for recapture.

* * * * *