

19



Europäisches Patentamt  
European Patent Office  
Office européen des brevets



11 Publication number:

**0 330 886 B1**

12

**EUROPEAN PATENT SPECIFICATION**

45 Date of publication of patent specification: **01.12.93** 51 Int. Cl.<sup>5</sup>: **F41G 3/26**

21 Application number: **89102322.8**

22 Date of filing: **10.02.89**

54 **Shooting simulator device.**

30 Priority: **24.02.88 IT 8332388**

43 Date of publication of application:  
**06.09.89 Bulletin 89/36**

45 Publication of the grant of the patent:  
**01.12.93 Bulletin 93/48**

84 Designated Contracting States:  
**AT BE CH DE ES FR GB GR LI LU NL SE**

56 References cited:  
**US-A- 3 453 385           US-A- 3 798 795**  
**US-A- 3 798 796           US-A- 4 209 832**  
**US-A- 4 439 156           US-A- 4 524 386**  
**US-A- 4 611 993**

73 Proprietor: **MICROFOX ENGINEERING DI FAR-  
FOGLIA M. & VOLPE M. Snc**  
**Via Aonez 19/F**  
**I-33100 Udine(IT)**

72 Inventor: **Volpe, Marco**  
**Via Franzolini 3**  
**I-33100 Udine(IT)**

74 Representative: **Petraz, Gilberto Luigi**  
**GLP S.r.l.**  
**Piazzale Cavedalis 6/2**  
**I-33100 Udine (IT)**

**EP 0 330 886 B1**

Note: Within nine months from the publication of the mention of the grant of the European patent, any person may give notice to the European Patent Office of opposition to the European patent granted. Notice of opposition shall be filed in a written reasoned statement. It shall not be deemed to have been filed until the opposition fee has been paid (Art. 99(1) European patent convention).

## Description

This invention concerns a shooting simulator device. To be more exact, the invention concerns an electronic device capable of being fitted to a light weapon and of cooperating therewith so as to simulate the effects of a shot fired from that light weapon.

This device is mainly employed in the field of training military personnel and others to fire with light weapons.

Electronic devices exist in the state of the art which simulate the firing of a shot from a light weapon. These devices provide, for instance, a means to send a luminous beam against a target represented on a television screen, such means having a form and dimensions like those of a light weapon, for instance a rifle or pistol.

Such devices entail a plurality of drawbacks inasmuch as they give a wholly artificial view which does not correspond to reality; moreover, the operations and effects typically linked to a shot fired with a real weapon, such as the adjustment of the backsight, graduated movements, the noise of the shot and the recoil of the weapon are generally missing.

US-A-3,798,796 discloses a method and a device for the training of personnel in the optical tracking of a moving target. The operator has at his disposal an optical instrument equipped with a controlling telecamera provided with a reticle for collimation purposes arranged or recreated with optical methods on the sensitive surface. The optical device of this invention is not a real weapon and simulates aiming only, no procedure to simulate a shot being provided.

This apparatus concerns optical aiming instruments equipped with a reticle and arranges that the instructor can watch continuously the person being trained and can provide instructions on how to proceed during the aiming process. This document is not intended to evaluate the skill of a shooter using a light weapon by supplying the shooting data as soon as a shot is fired but does so only after the shot has been fired.

US-A-4,439,156 concerns a training device for a simulated anti-tank weapons system. The device works in a simulated manner and concerns particularly anti-tank weapons and includes means to pre-arrange and move the terrain and target. The device provides for the need of a reference source on the target so that the shots can be assessed, and the data of the trajectory are processed. An array of photodiodes is used to establish the accuracy of the simulated shot.

US-A-4,524,386 discloses a thermal target display system by means of which it is possible to generate thermal radiation patterns simulating the

thermal "signature" of real-scene simulated objects such as vehicles, persons, etc. The system employs a plurality of heat-radiating thermal elements arranged in an array to form a thermal screen or target.

US-A-3,453,385 discloses an apparatus and method which employ electro-optical principles to display to an observer the field of view seen by a person aiming a firearm such as a rifle or the like.

US-A-4,209,832 discloses a system which provides a complete electronic simulation of a battle, whereas US-A-4,611,993 concerns a testing of real firing carried out by a tank employing tracer shells.

US-A-3,798,795, discloses a system to assess the accuracy with which a missile is aimed at a flying object, but deals with heavy weapons, namely weapons very different from those with which our invention is concerned. In this arrangement the firing action sets off a complex process of calculation, which compares the information coming from the videocamera, weapon and measurement systems so as to obtain the theoretical path of the missile and to compare that path with the path of the target aircraft. This calculation provides a hit/miss aim and the mistakes in the aiming data.

The videocamera is not mechanically linked to the weapon, as it is instead in the invention under examination, and has a wholly different purpose, namely to gather information so as to determine the trajectory of the movement of the target at which the heavy weapon is firing; in other words, the videocamera is not collimated with the weapon, as instead it is collimated in our invention, but has an aim unconnected with and generally different from that of the weapon itself.

The present invention has the purpose of obviating all the drawbacks and shortcomings of the state of the art and providing a device which, while simulating an actual situation in a fully realistic manner, can give at the same time an almost instantaneous recording and processing of the data linked to the shot fired. These and other purposes are attained by a device having the features described in Claim 1, while the dependent claims describe preferred forms of embodiment of the invention.

The device according to the invention has been embodied generally so as to enable conscript soldiers and others to be trained to shoot at targets with a rifle in small shooting ranges of 50 metres or in ranges of 100-300 metres.

The device is fitted to suitable guides included on the models of the rifles normally provided or to guides expressly made for the purpose and located at the side of the body of a rifle or other light weapon.

According to a particularly advantageous embodiment of the invention the device is fitted to

guides provided for the fixture of an infrared ray telescopic sight to the weapon.

After having acted on the traditional mechanical means available on the weapon itself, such as the backsight and graduated displacements, the shooter performs all the operations of loading, aiming and firing the rifle and then checks with a monitor to see where he has actually shot, thus finding out how, if necessary, he must correct his shot to hit the target.

According to the invention this is obtained by installing on the rifle or light weapon a system to verify the aim which consists of a telephoto lens, a telecamera, an electronic shutter and a shock sensor.

The telecamera and shock sensor are connected to a data processing unit, which is provided with means to store and digitise the image in real time and with suitable statistical calculation means.

The data processing unit is also able to restore for the user the image obtained by the telecamera by means of a shooting mask consisting of a pair of orthogonal segments positioned in the form of a cross, the intersection of the cross indicating the most likely point of impact of the bullet.

The position of the mask is determined by the data processing unit according to the shooting distance to be simulated in conformity with the characteristics of the weapon and ammunition employed.

The device can be used after carrying out alignment of the traditional sights with the electronic system, and this alignment can be performed preferably by assuming a situation of direct firing with the backsight at zero.

At the moment of shooting the image being obtained by the telecamera is stored by the data processing unit in a stable manner according to a command generated by the shock sensor.

The image is displayed thereafter on two different monitors, one of which is located beside the shooter, whereas the other is placed near a central control unit comprising the data processing unit.

In this way the shooter can see, owing to the firing mask superimposed by the data processing unit on the stored image displayed on the monitor, the point he would have hit on the target if he had fired a bullet.

This observation will also enable him to correct the next shot if necessary.

The monitor placed near the central control unit can be used to provide an overall view of the shots fired by various local independent units, to display the hits obtained by each shooting station and to give an assessment of the shooting, thereby producing a score card for each shooter.

Other purposes and advantages of the invention will become clear from the following descrip-

tion of one form of embodiment of the invention, this form being given as a non-restrictive example.

Fig.1 shows a three-dimensional view of a light weapon equipped with a device according to the invention;

Fig.2 gives a block diagram of the method of working of the device according to the invention.

In the figures a computerised electronic device 10 according to the invention is fitted to a support bracket 11 and is solidly fixed to a light weapon 12, which in this example is shown as being a rifle as supplied to the Italian army.

The support bracket 11 comprises a slide that cooperates with a guide located on one side of the body of the light weapon 12.

This guide is normally included on light combat weapons and serves for the installation of an infrared ray sighting device.

If the guide is not included on the body of the light weapon 12, it is supplied together with the support bracket 11 and is secured to the body of the light weapon 12.

The actual device 10 itself comprises an optical assembly 13-15 and a telecamera 13, a shutter 14 and a telephoto lens 15.

In this particular example the telecamera 13 is shown as being a black and white static telecamera equipped with a CCD sensor and is able to withstand very strong impacts and stresses.

Fig.1 shows an electronic shutter 14 placed between the telecamera 13 and the telephoto lens 15 and joined to them by a special attachment.

The electronic shutter 14 consists generally of a liquid-crystals means which, being polarized suitably with a control voltage, enables a system providing selection of the light passing through to be obtained.

The response time of this electronic shutter 14 can attain an order of magnitude of one thousandth of a second.

The inclusion of the electronic shutter 14 makes possible the fixture in the telecamera 13 of an image relating to a very short exposure time, and this prevents and eliminates the vibrations of the video image due to sudden movements of the weapon during aiming and firing.

An optical means, which in this particular example consists of a 300 mm. telephoto lens available on the market, is connected to the shutter 14.

There form part, of course, of the purposes of the invention forms of embodiment in which the telecamera 13, electronic shutter 14 and telephoto lens 15 possess technical characteristics differing even widely from those described above.

A shock sensor 17 is also fitted below the support bracket 11 and can emit a signal corresponding to the impact of the striker at the mo-

ment of firing. The signal emitted by the shock sensor 17 and the images coming from the telecamera 13 are transmitted by suitable cables to a data processing unit 16 consisting generally of a personal computer.

This data processing unit 16 is provided with a circuit by means of which the images arriving from the telecamera 13 are digitised and stored, and is also provided with an on/off digital input circuit connected to the shock sensor 17.

Moreover, the data processing unit 16 is equipped with specialised software which makes possible, for instance, the generation of the electronic target mask in the cited form of a cross and the statistical processing of the shooting data together with a simultaneous view, at the central unit, of the firing performance of the various separate shooting stations.

This software is structured in such a way as to enable a plurality of parameters (type of rifle, distance of target, etc.) to be introduced into the data processing unit which provide a basis for the subsequent processing of the shooting data.

Fig.2 shows the telecamera 13, shock sensor 17, a shunt block forming an interface 18 and comprising a feed unit, and the data processing unit 16 provided with a first monitor 19 for use by the person in charge of the range and with a second monitor 20 positioned generally near the shooter.

The above device corresponds to a special form of embodiment of the invention, which is used in this case for the training of military personnel in shooting. However, the purposes of the invention cover forms of embodiment and employment which may differ even widely from those described above.

For instance, the invention covers a form of embodiment whereby the telecamera 13 is transferred and supported apart from the weapon. The transmission of the image between the telecamera and the weapon is achieved by lines of optically insulated glass fibres, and this form of embodiment is particularly advantageous as regards the light weight of the whole device.

The invention also covers forms of embodiment whereby the data processing unit consists not of a personal computer but of a microcomputer or minicomputer with all the technical consequences concerning possible increases in the number of data to be processed and in the connected shooting capabilities which can be supervised at one and the same time.

The purposes of the invention, of course, cover forms of embodiment whereby the device is fitted to any light weapon and is used by non-military personnel, in a private shooting club for instance.

## Claims

1. Computerized electronic device (10) to verify the aiming of a light weapon (12) fired directly at a target, which comprises a telecamera (13), a data processing unit (16) and at least one monitor (19-20), the image provided by the telecamera (13) collimating with the image obtainable through the sights of the light weapon (12), characterized in that the telecamera (13) is part of an optical assembly (13-15), which is connected to a data processing unit (16), said assembly being fitted to a support bracket (11) which is solidly fixed to the body of the weapon (12), said assembly including an electronic shutter (14) and a telephoto lens (15); the moment of shot being detected by the data processing unit (16), the shutter means (14) being activated when a shot is detected, the optical assembly (13-15) then supplying an image to the data processing unit (16), said image being processed to generate an output indicating the target and the most likely impact point of a projectile, said impact point being calculated on the basis of the shooting distance and the characteristics of the weapon (12) and ammunition.
2. Device as in Claim 1, in which a shot is detected by a sensor (17) that emits an electrical signal representing the moment of firing, the sensor (17) being connected to the data processing unit (16).
3. Device as in Claim 1 or 2, in which the data processing unit (16) cooperates with an interface block (18).
4. Device as in any claim hereinbefore, in which the data processing unit (16) cooperates with a means which digitises and stores images received from the optical assembly (13-15).
5. Device as in any of Claims 2 to 4 inclusive, in which the data processing unit (16) cooperates with an on/off digital input printed circuit connected to the sensor (17).

## Patentansprüche

1. Computerunterstützte Elektronikeinrichtung (10) zum Feststellen des Ziels einer Lichtstrahlenwaffe (12), die direkt auf ein Ziel abgefeuert wird, welches eine Fernsehkamera (13), eine Datenverarbeitungseinheit (16) und zumindest einen Monitor (19-20) aufweist, wobei das von der Fernsehkamera (13) gelieferte Bild mit dem durch das Visier der Lichtstrahlenwaffe

- (12) erhaltenen Bild ausgerichtet ist, **dadurch gekennzeichnet, daß** die Fernsehkamera (13) ein Teil einer optischen Anordnung (13-15) ist, welche mit einer Datenverarbeitungseinheit (16) verbunden ist, wobei diese Anordnung an einer Halterungsklammer (11) angebracht ist, welche fest mit dem Körper der Waffe (12) verbunden ist, und die Anordnung einen elektronischen Verschuß (14) und ein Teleobjektiv (15) aufweist, wobei der Schießzeitpunkt von der Datenverarbeitungseinheit (16) festgestellt wird, das Verschlußmittel (14) bei Feststellen eines Schusses aktiviert wird, die optische Anordnung (13-15) sodann ein Bild zur Verarbeitung an die Datenverarbeitungseinheit (16) liefert, um eine Ausgabe zu erzeugen, welche das Ziel und den wahrscheinlichsten Auftreffpunkt des Projektils anzeigt, und dieser Auftreffpunkt auf Basis der Schußdistanz und der Waffen- (12) und Munitionscharakteristik berechnet wird.
2. Vorrichtung nach Anspruch 1, bei welcher ein Schuß durch einen Sensor (17) festgestellt wird, welcher ein elektrisches Signal abgibt, das den Zeitpunkt des Abfeuerns angibt, wobei der Sensor (17) mit der Datenverarbeitungseinheit (16) verbunden ist,
3. Vorrichtung nach Anspruch 1 oder 2, bei welcher die Datenverarbeitungseinheit (16) mit einer Schnittstelleneinheit (18) zusammenwirkt.
4. Vorrichtung nach einem der vorigen Ansprüche, bei welcher die Datenverarbeitungseinheit (16) mit einem Mittel zusammenwirkt, welches die von der optischen Anordnung (13-15) erhaltenen Bilder digitalisiert und speichert.
5. Vorrichtung nach einem der Ansprüche 2 bis 4, bei welcher die Datenverarbeitungseinheit (16) mit einer Ein/Aus-Schaltungskarte mit digitalem Eingang zusammenwirkt, welche mit dem Sensor (17) verbunden ist.
- une unité de traitement de données (16), l'ensemble étant monté sur une console de support (11) qui est solidement fixée au corps de l'arme (12), cet ensemble comprenant un obturateur électronique (14) et un objectif de téléphotographie (15), le moment du tir étant détecté par l'unité de traitement de données (16), l'obturateur (14) étant activé lorsqu'un coup est détecté, l'ensemble optique (13-15) fournissant alors une image à l'unité de traitement de données (16), cette image étant traitée pour produire une sortie indiquant la cible et le point d'impact le plus probable d'un projectile, ce point d'impact étant calculé sur la base de la distance de tir et des caractéristiques de l'arme (12) et des munitions.
2. Dispositif suivant la revendication 1, dans lequel un coup est détecté par un détecteur (17) qui émet un signal électrique représentant le moment du tir, le détecteur (17) étant connecté à l'unité de traitement de données (16).
3. Dispositif suivant la revendication 1 ou 2, dans lequel l'unité de traitement de données (16) coopère avec un bloc d'interface (18).
4. Dispositif suivant l'une quelconque des revendications précédentes, dans lequel l'unité de traitement de données (16) coopère avec un moyen qui numérise et mémorise des images reçues de l'ensemble optique (13-15).
5. Dispositif suivant l'une quelconque des revendications 2 à 4 incluse, dans lequel l'unité de traitement de données (16) coopère avec un circuit imprimé à entrée numérique, marche/arrêt, connecté au détecteur (17).

## Revendications

1. Dispositif électronique informatisé (10) destiné à vérifier le pointage d'une arme individuelle (12) tirant directement sur une cible, qui comprend une caméra de télévision (13), une unité de traitement de données (16) et au moins un moniteur (19, 20), l'image fournie par la caméra de télévision (13) se collimatant avec l'image pouvant être obtenue à travers les viseurs de l'arme individuelle (12), caractérisé en ce que la caméra de télévision (13) fait partie d'un ensemble optique (13-15) qui est connecté à

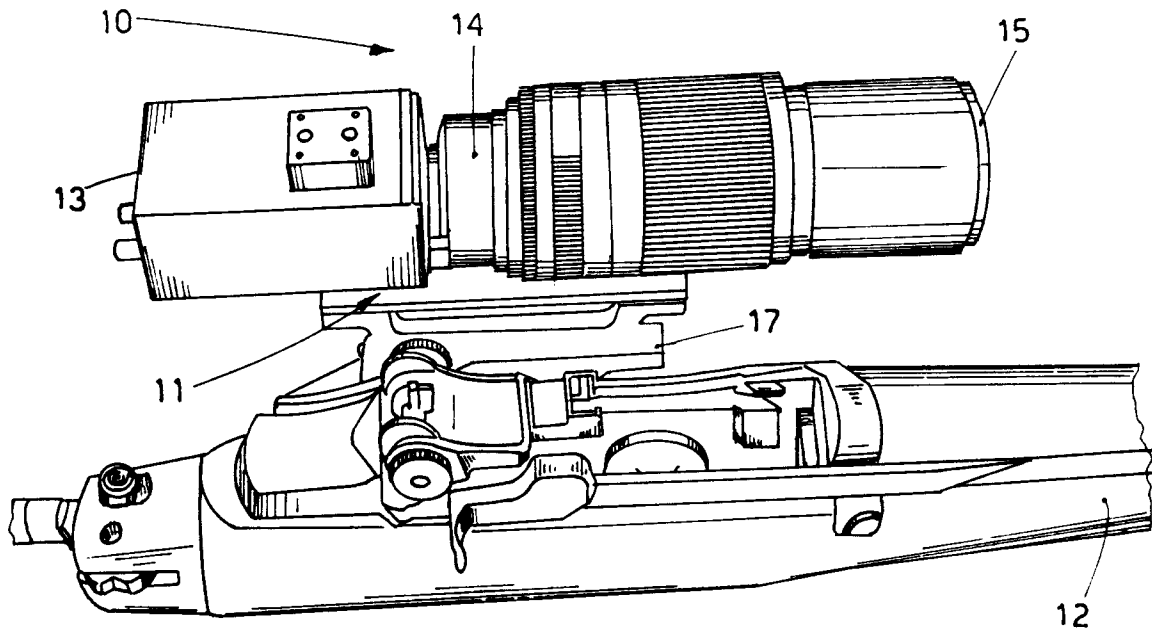

fig.1

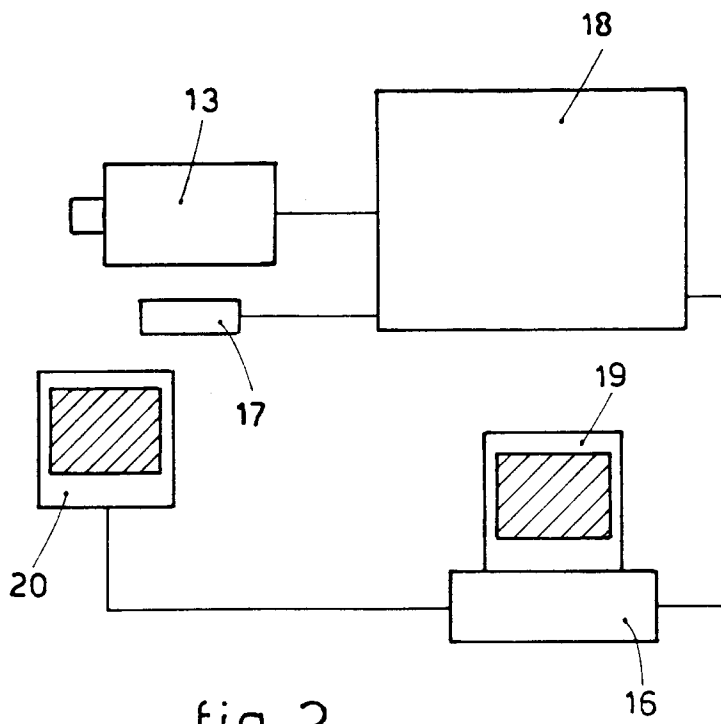

fig.2