

(12) PATENT
(19) AUSTRALIAN PATENT OFFICE

(11) Application No. AU 199855483 B2
(10) Patent No. 730041

(54) Title
Method and device for driving bore holes, specially exploring and extraction drillings in the sea bottom

(51)⁷ International Patent Classification(s)
E21B 004/00 E21B 007/12

(21) Application No: **199855483**

(22) Application Date: **1997.11.27**

(87) WIPO No: **WO98/26151**

(30) Priority Data

(31) Number	(32) Date	(33) Country
19651303	1996.12.10	DE
19702984	1997.01.28	DE

(43) Publication Date : **1998.07.03**

(43) Publication Journal Date : **1998.09.03**

(44) Accepted Journal Date : **2001.02.22**

(71) Applicant(s)
Wirth Maschinen- Und Bohrgerate-Fabrik GmbH

(72) Inventor(s)
Fritz Tibusek; Hermann-Josef Von Wirth

(74) Agent/Attorney
BALDWIN SHELSTON WATERS, Level 21, 60 Margaret Street, SYDNEY NSW 2000



<p>(51) Internationale Patentklassifikation ⁶ : E21B 004.00, E21B 007.12 SEARCH QUALITY ASSURANCE</p>	<p>A2</p>	<p>(11) Internationale Veröffentlichungsnummer: WO 98/26151 (43) Internationales Veröffentlichungsdatum: 18. Juni 1998 (18.06.98)</p>
--	-----------	---

<p>(21) Internationales Aktenzeichen: PCT/DE97/02770 (22) Internationales Anmeldedatum: 27. November 1997 (27.11.97) (30) Prioritätsdaten: 196 51 303.0 10. Dezember 1996 (10.12.96) DE 197 02 984.1 28. Januar 1997 (28.01.97) DE (71) Anmelder (für alle Bestimmungsstaaten ausser US): WIRTH MASCHINEN- UND BOHRGERÄTE-FABRIK GMBH [DE/DE]; Kölner Strasse 71-78, D-41812 Erkelenz (DE). (72) Erfinder; und (75) Erfinder/Anmelder (nur für US): TIBUSSEK, Fritz [DE/DE]; Kaldenkirchener Strasse 6c, D-41063 Mönchengladbach (DE). VON WIRTH, Hermann-Josef [DE/DE]; Schillerstrasse 12, D-52445 Titz (DE). (74) Anwälte: PALGEN, Peter usw.; Mulvanystrasse 2, D-40239 Düsseldorf (DE).</p>	<p>(81) Bestimmungsstaaten: AU, CN, JP, KR, US, europäisches Patent (AT, BE, CH, DE, DK, ES, FI, FR, GB, GR, IE, IT, LU, MC, NL, PT, SE). Veröffentlicht <i>Ohne internationalen Recherchenbericht und erneut zu veröffentlichen nach Erhalt des Berichts.</i></p>
--	--

(54) Title: METHOD AND DEVICE FOR DRIVING BORE HOLES, SPECIALLY EXPLORING AND EXTRACTION DRILLINGS IN THE SEA BOTTOM

(54) Bezeichnung: VERFAHREN UND VORRICHTUNG ZUM NIEDERBRINGEN VON BOHRLÖCHERN, INSBESONDERE FÜR SCHÜRF- UND GEWINNUNGSBOHRUNGEN, IN DEN MEERESBODEN

(57) Abstract

The invention relates to a method and a device for driving bore holes, specially exploring and extraction drillings in the sea bottom (40). According to the invention, the sea bottom is slackened by means of a rotating drilling head (10) which is fitted to the lower end of a drill string (5) designed for transmitting torque. The upper end of the drill string is mounted on a floating platform (1), wherein the drill string (5) is composed of at least two telescopically interfitting string parts (6, 7), which during a vertical movement of the platform, e.g. a movement induced by the sea swell, exert a relative movement with respect to each other so that the drilling head (10) rests with a substantially constant force on the surface to be cleared away.

(57) Zusammenfassung

Verfahren und Vorrichtung zum Niederbringen von Bohrlöchern, insbesondere von Schürf- und Gewinnungsbohrungen, in den Meeresboden (40). Der Meeresboden wird mit Hilfe eines rotierenden Bohrkopfes (10) gelöst, der am unteren Ende eines für die Übertragung eines Drehmoments geeigneten Bohrstranges (5) angeordnet ist. Das obere Ende des Bohrstranges ist auf einer schwimmenden Plattform (1) gelagert, wobei der Bohrstrang (5) aus mindestens zwei teleskopartig ineinandergreifenden Strangteilen (6, 7) besteht, die bei einer vertikalen, beispielsweise durch die Meeresdünung induzierten Bewegung der Plattform eine Relativbewegung zueinander ausüben, so daß der Bohrkopf (10) mit im wesentlichen konstanter Kraft an der abzutragenden Oberfläche aufliegt.

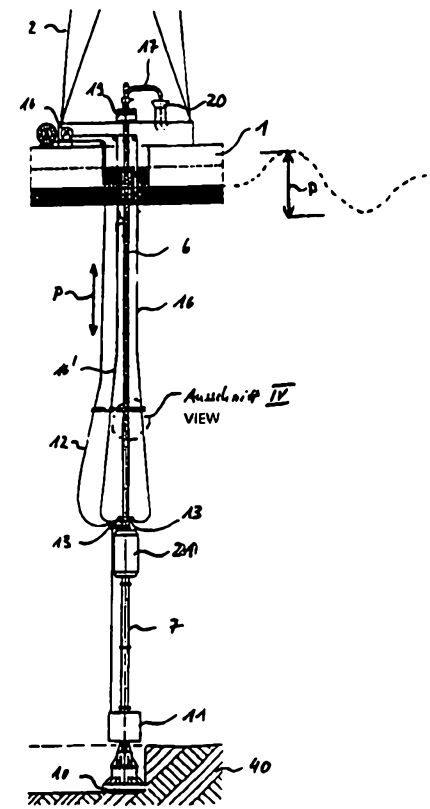

WIRTH MASCHINEN- UND BOHRGERÄTEFABRIK GMBH

Kölner Straße 71 - 78

D - 41812 Erkelenz

Abstract

5 Method of, and apparatus for, sinking bore
holes, in particular exploratory and extraction bore
holes, in the sea bed (40). The material from the sea
bed is loosened with the aid of a rotating drill head
(10) which is arranged at the bottom end of a drill
10 string (5) which is suitable for transmitting a torque.
The top end of the drill string is mounted on a
floating platform (1), it being the case that the drill
string (5) comprises at least two telescopically
interengaging drill-string parts (6, 7) which, during a
15 vertical movement of the platform, induced for example
by the sea swell, execute a movement relative to one
another, with the result that the drill head (10) rests
with an essentially constant force on the surface which
is to be cleared away. (Figure 3).



WIRTH MASCHINEN- UND BOHRGERÄTEFABRIK GMBH
in 41812 Erkelenz

Method of, and apparatus for, sinking bore holes, in
particular exploratory and extraction bore holes, in
5 the sea bed

The invention relates to a method of, and an
apparatus for, sinking bore holes, in particular
exploratory and extraction bore holes.

Exploratory bore holes are intended for the
10 purpose of examining deposits and to make it possible
to take samples of the material present in the deposit.
Exploratory bore holes are sunk, in particular, when
the deposit is at a considerable depth and/or bodies of
water lying above the deposit, such as seas or oceans,
15 preclude the possibility of sinking exploratory shafts.

Extraction bore holes serve the purpose of
loosening deposit contents from soil strata. An example
for extraction bore holes which may be mentioned is the
extraction of marine sediments with diamond inclusions
20 deposited on the sea bed. Such diamond-containing
deposits have usually formed upstream of estuaries in
the form of reasonably sized layers spread out over a
rocky base. For extracting the diamond-containing
sediment material, use is usually made of apparatuses
25 which comprise a drill head which is lowered to the sea
bed with the aid of an extensible drill-pipe string
extending from a floating platform. Floating platform



is to be understood as any arrangement of which the height above the sea bottom or ocean floor depends on the water level at any one time. Drilling vessels are particularly suitable here.

5 In order to make the drill head rotate, this rotational movement being required for the drilling operation, either said drill head is arranged in a rotationally fixed manner on the drill-pipe string and the latter is made to rotate with the aid of a rotary
10 drive (powered rotary head) arranged above the platform, or the drill string is mounted in a rotationally fixed manner on the platform and there is provided a drive which makes the drill head rotate with respect to the drill string.

15 The overburden which is loosened during the drilling operation is usually delivered up to the platform, through the interior of the drill string, by so-called "reverse circulation" - for example by using the known air-lift method - and at the platform is fed,
20 via a pipe bend which is provided at the top end of the drill string and is in connection with the inner volume thereof, to arrangements in which diamonds and overburden are separated in a known manner.

 Since the prerequisite for a satisfactory
25 drilling result is that the drill-head end side which is equipped with at least one cutting tool always butts throughout the drilling operation, with an approximately constant advancement pressure against the

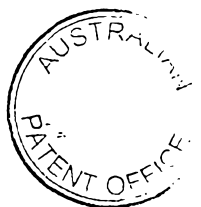

end side of the bore hole, the platform comprises an arrangement which allows a vertical movement of the platform, called for example by sea swell, without this resulting in the advancement force fluctuating to any great extent or in the drill head being lifted off from the sea bed at all. Such arrangements comprise pneumatic or hydraulic/pneumatic piston/cylinder arrangements which are usually connected to a relatively large equalizing volume and are connected, for example, on the cylinder side to the drill string and, on the piston side, to an arrangement which bears the drill string, for example a drilling derrick. The equalizing volume connected to the cylinders means that the platform can execute vertical movements without the force with which the drilling tool butts against the sea bed changing to any considerable extent. If the fastening point of the piston/cylinder arrangement on the platform side is located beneath those on the drill string, then it is possible, by adjusting the pressure in the equalizing reservoirs, for the contact pressure of the drill head on the sea bed to be adjusted to a desired value from a maximum of the resultant weight.

Although such arrangements for equalizing vertical movements of the platform have frequently been used for some time now, it is disadvantageous that the drill string has to project out of the top side of the platform at least by half the maximum expected displacement of the vertical movement of the platform -



in relation to the central position thereof - and it is also only at this height that it is possible to fit the pipe bend which is necessary for discharging the overburden to the separating arrangement. This is disadvantageous because, on the one hand, the center of gravity of the platform is displaced upward to a considerable extent, as a result of which the period in which the weather is favorable enough for use of the platform is reduced, and, on the other hand, the overburden has to be delivered up to the level of the pipe bend. This is associated with high energy outlay, in particular, when the platform is located at its lowest level, for example in a wave trough, since the energy outlay depends on the height of the pipe bend above the water surface.

US Patent 3,319,726 discloses an apparatus which is intended for sinking bore holes in the sea bed and in the case of which, in order to equalize the vertical movement of the platform, the drill string comprises two telescopically interengaging drill-string parts which can be displaced axially relative to one another. Serving for mounting the inner and outer drill-string parts is a high-outlay arrangement which comprises a plurality of seals and floating pistons for pressure equalization, is filled with a hydraulic fluid and is fully encapsulated toward the outside against the penetration of sediment. The disadvantage with this apparatus is that it involves high outlay to produce



and its complicated construction makes it susceptible to malfunctioning.

Furthermore, US Patent 3,259,198 and US Patent 3,664,443 disclose apparatuses in the case of which the drill string comprises a telescopic part which is intended to equalize, inter alia, the movement induced by the sea swell. In the case of these

5 apparatuses, the drilled material is delivered upward via the interior of the drill string by fresh water being fed to the bore hole under pressure. For this purpose, the drill string contains two concentrically arranged tubes which form an annular gap between them. The fresh water is fed by way of the annular gap, and the drilled material is transported away by way of the inner tube. The drill strings of these apparatuses too involve higher
10 outlay to produce.

It is an object of the present invention to overcome or ameliorate at least one of the disadvantages of the prior art, or to provide a useful alternative.

According to a first aspect of the invention there is provided a method of sinking bore holes, in particular exploratory and extraction bore holes, in the sea bed, in the case
15 of which method the latter is loosened with the aid of a rotating drill head which is arranged at the bottom end of a drill string which is suitable for transmitting a torque and of which the top end is mounted on a floating platform, it being the case that the drill string comprises at least two telescopically interengaging drill-string parts which, during a vertical movement of the platform, induced for example by the sea swell, execute a
20 movement relative to one another, with the result that the drill head rests with an essentially constant force on the surface which is to be cleared away, wherein material from the sea bed which has been loosened is delivered out of the bore hole, through the interior of the drill string, by using the air-lift method.



Unless the context clearly requires otherwise, throughout the description and the claims, the words 'comprise', 'comprising', and the like are to be construed in an inclusive sense as opposed to an exclusive or exhaustive sense; that is to say, in the sense of "including, but not limited to".

5 According to another aspect of the invention there is provided an apparatus for sinking bore holes, in particular exploratory and extraction bore holes, in the sea bed, having a drill string which is suitable for transmitting a torque and of which the top end is mounted on a floating platform and of which the bottom end bears a rotationally driveable drill head and which comprises a plurality of drill-string parts which can be
10 displaced with low friction in the axial direction of the drill string relative to one another, wherein there is provided an air inlet which is in connection with the drill-string interior and through which it is possible to blow in compressed air fed via a pressure line.

 Since, in the case of the method according to the invention, the drill string comprises at least two telescopically interengaging drill-string parts which, during a
15 vertical movement of the platform, induced for example by the sea swell, execute a movement relative to one another, it is no longer necessary for the drill string to project beyond the platform by at least half the maximum expected vertical deflection of the platform; rather, it is possible for the top end of the drill string to be located directly above the platform surface. As a result, on the one hand, this considerably reduces the
20 height of the center of gravity of the platform, with the result that, in relation to those platforms in the case of which the vertical movement is equalized above the platform, it is also possible to use this platform in rough seas, and, on the other hand, the now likewise lower pipe bend considerably reduces the delivery height which is necessary for



lifting the overburden, with the result that, with the energy requirement remaining the same, the delivery quantity can be increased or else, with the delivery quantity remaining the same, the energy requirement can be lowered. The negative pressure which prevails in the interior of the drill string when use is made of the air-lift method, which is known
5 per se from FR 2523205 for example, means that a certain quantity of surrounding water is always sucked in through the annular gap which is inevitably located between the telescopically interengaging drill-string parts, so that there is always water circulating around this region, as a result of which any sediment parts which may have penetrated are always washed out. It is thus possible to dispense with seals and specially protected
10 mounting arrangements.

In the case of one possible embodiment of the method according to the invention, the drill head is arranged in a rotationally fixed manner on the drill string. In order to produce the rotation of the drill head, there is provided on the platform a drive which makes the drill string rotate (Claim 2).

15 In the case of the preferred embodiment of the method according to Claim 3, however, the drill string is mounted in a rotationally fixed manner on the platform and the drill head is made to rotate relative to the drill string. By virtue of this configuration, on the one hand, the drive which increases the weight of the platform and possibly displaces its center of gravity upward is rendered superfluous and, on the other hand, it is
20 possible for the drill string to

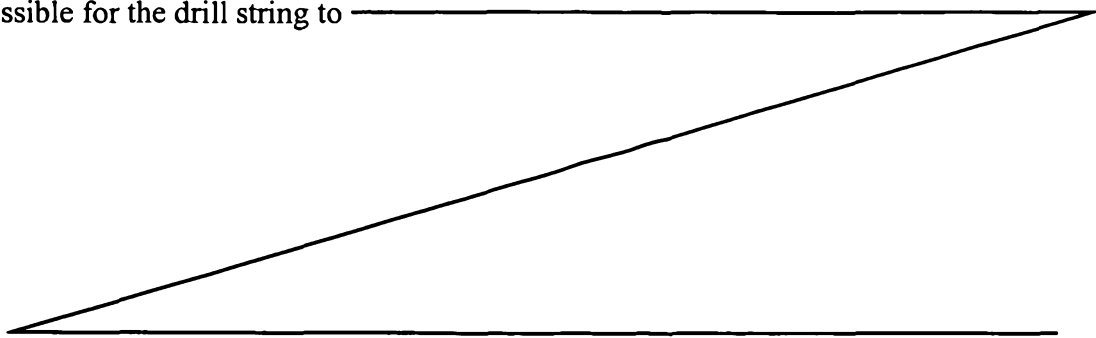

serve for routing electric, hydraulic or similar lines without high-outlay rotary lead-throughs or couplings being required for this purpose. It is then also easily possible for one end of a cable which is routed to the platform to be fitted on the bottom drill-string part, 5 as a result of which it is possible, without high energy outlay, for the bottom drill-string part, together with the drill head, to be lifted, for example, from the bottom of the bore hole and displaced 10 over the sea bed to the location at which a further bore hole is to be sunk.

The apparatus-related aspect of the invention is given in Claim 4.

In the case of a preferred embodiment according to Claim 5, the drill string comprises an outer and an 15 inner drill-string part, it being the case that - in order that the vertical movement of the platform can be equalized - the inner drill-string part is pushed into the outer drill-string part in the normal position of the platform, at least over a length which corresponds 20 to the maximum upward vertical movements of the platform which are to be expected as a result of sea swell or the like, and can be displaced further into the outer drill-string part, at least by an amount 25 which corresponds to the maximum expected downward deflection of the platform out of its normal position.

Since the inner and outer drill-string parts have to be connected to one another in a rotationally

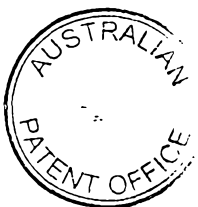

fixed manner, in order to be able to transmit the drive torque or the reaction torque, a configuration of the drill string according to Claim 6 is recommended. This ensures that, despite the fact that they are fixed
5 rotationally, a low-friction movement of the two drill-string parts relative to one another is possible.

A particularly preferred technical configuration of the mounting which works on this principle forms the subject matter of Claims 7 to 10.

10 It is possible, on the one hand, for the outer drill-string part to be arranged on the platform by way of its top end and for the drill head to be arranged at the bottom end of the inner drill-string part. In the case of the preferred embodiment according to Claim 11,
15 however, the arrangement is the other way round, since the top, preferably longer top [sic] drill-string part, which during the drilling operation, in a vertical direction, is connected rigidly to the platform, comprises components which involve less outlay to
20 produce.

In the case of a first possible embodiment of the apparatus according to the invention, there is provided on the platform an arrangement with which the drill string can be provided [sic] to rotate about its
25 longitudinal axis. In this case, the drill head is arranged in a rotationally fixed manner on the drill string.

In the case of the preferred embodiment



according to Claim 13, however, the drill string is mounted in a rotationally fixed manner on the platform and there is provided a rotary drive, with the aid of which the drill head can be made to rotate with respect
5 to the drill string.

In the case of this [sic] preferred embodiment according to Claim 14, the rotationally fixed mounting of the drill string on the platform preferably takes place by means of a rotationally fixed, cardanic
10 retaining means (gimbal).

The drill head is preferably driven either electrically or hydraulically (Claims 15 and 16), it being the case that the drive arrangements are preferably integrated in the drill head or are arranged
15 directly above the same.

The pressure line which is required for using the air-lift method may, according to Claim 17, be secured on the outer circumference of the drill string and run parallel to the longitudinal center axis
20 thereof.

In the case of an advantageous embodiment, however, the pressure line is designed as a pressure hose which can be unrolled from a winding drum (Claim 18). This measure has the advantage that the pressure
25 hose can easily be connected both to the top drill-string part and to the bottom drill-string part.

An advantageous development of the apparatus according to the invention forms the subject matter of



Claim 19. In this case, at least one buoyancy element is arranged on the drill-string part which bears the drill head. In the case of the apparatus according to the invention, selection of the buoyancy volume of the
5 buoyancy element makes it possible to adjust the desired contact pressure of the drill head on the sea bed.

In order to avoid the situation where the bottom drill-string part is subjected to compressive
10 loading by too high a buoyancy volume of the buoyancy element, it is advantageous, according to Claim 20, for the at least one buoyancy element to be arranged in the vicinity of the top end of the bottom drill-string part.

15 Straightforward adjustment of the contact pressure, this adjustment also being possible once the drill head has been lowered onto the sea bed, is provided if the buoyancy elements are designed as floodable tanks which can be filled with compressed air
20 as desired, via corresponding compressed-air lines, possibly by a compressor located on the platform (Claim 21).

If, according to Claim 22, a buoyancy element is also provided on the drill-string part which is
25 mounted on the platform, it is possible to compensate for some of the weight acting on the platform, with the result that heavier, and thus longer, drill-string parts can be secured and the apparatus is also suitable



for sinking exploratory bore holes at considerable depth.

A preferred embodiment of the invention will now be described, by way of example only, with reference to the accompanying drawings, in which:

Figure 1 shows a side view of an embodiment of the apparatus according to the invention in the case of which the drill string has already been assembled to its full length, but has not yet been lowered into its operating position;

Figure 2 shows the same embodiment with a drill string which is located in its operating position on the platform but has the drill head lifted off from the sea bed;

Figure 3 shows the same embodiment at the end of a drilling operation;

Figure 4 shows an enlarged illustration of the detail IV in Figure 3;

Figure 5 shows a cross section along section line V-V in Figure 4 and [sic] an illustration, in longitudinal section and in detail form, of the drill string in the region in which the inner drill-string part projects into the outer drill-string part.

The apparatus, which is designated as a whole by 100 in Figures 1 to 3, comprises a mast 2 which is arranged on a floating platform 1 and is only indicated in Figures 1 to 3. As is likewise merely indicated in Figure 1, it is equipped with a block and tackle 3

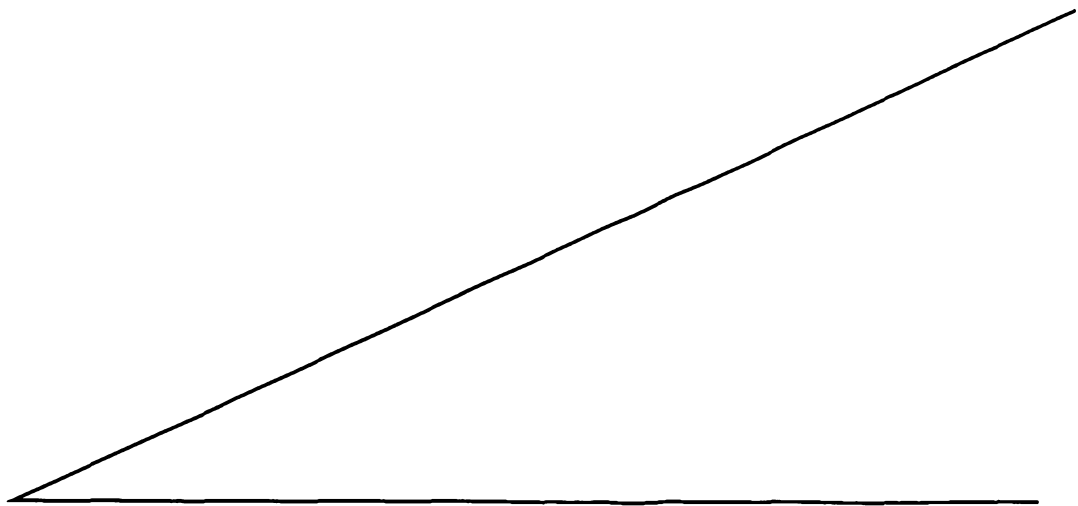

which serves for lifting or lowering one or more segments 4, 4' of a drill string, which is designated as a whole by 5.

5 Serving for providing and transferring the drill-string segments 4, 4' to the block and tackle 3 are means which are known for this purpose and are usually referred to as pipe erector or pipe handling system, but are not illustrated in the drawing.

10 The drill string 5, which - as has already been explained in the introduction - comprises removable segments 4, 4', has a top drill-string part 6 and a bottom drill-string part 7. The top drill-string part 6 opens out telescopically into the bottom drill-string part 7 at the location 8 and, according to the
15 illustration in Figure 1, projects into said bottom drill-string part approximately as far as location 9. The top and the bottom drill-string parts 6, 7 are configured in that length region which is provided for the insertion of the top drill-string part, such that,
20 in this length region, the drill-string parts 6, 7 can move with low friction relative to one another in the longitudinal direction of the drill string, although rotation of the two drill-string parts 6, 7 with respect to one another about the longitudinal center
25 axis of the drill string is not possible. A type of mounting which exhibits these functional features is described in more detail hereinbelow with reference to Figures 4 and 5.



Arranged at the bottom end of the bottom drill-string part is a drill head 10 which, with the aid of a rotary drive 11 arranged above it on the bottom drill-string part, can be rotated relative to the drill string 5, which in the exemplary embodiment is mounted in a rotationally fixed manner in the platform and absorbs the reaction torque. In the exemplary embodiment illustrated, the power source used is a hydraulic motor which is supplied with hydraulic fluid under pressure via a hydraulic line 12. However, it is likewise possible to use an electric drive instead of the hydraulic drive and to provide an electric line instead of the hydraulic line 12.

Provided at the top end of the bottom drill-string part are two eye elements 13 on which there are fastened two cables 16' which run through an opening 14, provided in the platform and through which the drill string 5 also extends, and are fed to a winch 16 via deflection rollers 15. The bottom drill-string part can thus be lifted and lowered by virtue of the winch 16 being actuated.

First of all the basic functioning of the apparatus according to the invention is to be described hereinbelow with reference to Figures 1 to 3.

In the phase which is illustrated in Figure 1, the drill string 5 has already been assembled to its full length by the screw-connection of individual segments 4 and 4'. Arranged at the top end of the drill



string is the pipe bend serving for the discharge of
lifted overburden. By virtue of the block and tackle 3
and the winch 16 being paid out synchronously, the
drill-string parts 6, 7 are lowered until the top
5 region 18 of the top drill-string part 6 is located
level with a cardanically mounted retaining means 19
(gimbal), which is illustrated schematically in the
open state in Figure 1.

The top drill-string part is fixed in this
10 position by virtue of the retaining means 19 being
closed. This state is illustrated in Figure 2. The pipe
bend 17 then opens out into an inlet 20 which is
widened in the form of a funnel at its end and feeds
the overburden to a known arrangement (not illustrated
15 in the drawing) for separating off diamonds contained
in the overburden.

In the state which is illustrated in Figure 2,
the apparatus 100 is positioned such that the drill
head is located above that part of the sea bed which is
20 to be cleared away.

Before the actual drilling operation begins,
the winch 16 is paid out, as a result of which the
bottom drill-string part 7 is lowered further, by
sliding down on that part of the top drill-string part
25 6 which projects into it, until the drill head 10 rests
on the sea bed. The cables 16' are then paid out
further, with the result that - as is illustrated in
Figure 3 - they hang down in a slack loop. The



resultant weight of the bottom drill-string part 7 and of the components connected thereto determines the contact pressure between the end side of the drill head and the sea bed. During further advancement of the
5 drill head 10 into the sea bed 20 [sic], the bottom drill-string part 7 can slide down further without obstruction from the top drill-string part 6.

If the platform - induced for example by the sea swell - executes a vertical movement, as is
10 intended to be symbolized by the double arrow in Figure 3, it being possible for this vertical movement to measure quite a few meters, depending on the weather conditions then the contact pressure of the drill head
15 10 on the sea bed 40 is not affected as a result since the inner drill-string part 6 can be displaced with low friction in and out of the bottom drill-string part 7 corresponding to the vertical movement of the platform.

In order for it to be possible to adjust the end-side contact pressure of the drill head 10 on the
20 sea bed 40, a buoyancy unit 21 is arranged in the region of the top end of the bottom drill-string part. This buoyancy unit comprises a plurality of tanks (not shown in the drawing) which may optionally be flooded or, with the aid of over [sic] compressed-air lines
25 (not illustrated in the drawing) emptied, with the result that the buoyancy can be adjusted and the resultant contact pressure between the drill head and the sea bed can thus be reduced to the value required



in each individual case.

A preferred technical configuration of the mounting between the top and the bottom drill-string parts 6, 7 is to be explained hereinbelow with
5 reference to Figures 4 and 5.

The top drill-string part, which is of essentially tubular configuration, comprises a tubular part 23 which has a round cross section and is subdivided into segments 4 which can be screw-connected
10 to one another by means of flanges. Over its length which can be introduced into the bottom drill-string part, four angle profiles 22, which are distributed uniformly over the circumference, are arranged on the tubular part 23 parallel to the longitudinal center
15 axis L. Each angle profile 22 comprises two legs 22', 22'' which are at right angles with respect to one another. The angle profiles 22 are welded over their length - in any case in certain sections thereof - to the tubular part 23 of the top drill-string part 6 by
20 way of the free edges of the legs 22', 22''.

Serving for mounting the top drill-string part 6 in the bottom drill-string part 7, said mounting allowing the top and bottom drill-string parts to move relative to one another in the axial direction and
25 being suitable for transmitting torques directed about the longitudinal center axis L, are roller arrangements 24 which are arranged on the bottom drill-string part 7, are distributed over the circumference,



corresponding to the angle profile 22, and are in operative connection with the angle profiles. Each roller arrangement 24 comprises two pairs of rollers 25, 26, it being the case that the rollers 25, 25'; 26, 26' belonging to a pair are spaced apart from one another in the direction of the longitudinal center axis and have their axes of rotation running parallel to one another, whereas the axes of rotation of the roller pairs 25, 26 of a roller pair [sic] 24 are aligned perpendicularly to one another. In the case of the exemplary embodiment which is illustrated in Figure 4, two sets of in each case four roller arrangements 24, 24' are provided in the longitudinal direction of the drill string in order for it to be possible to prevent canting of the top drill-string part in the bottom drill-string part. However, it is likewise possible to provide a greater number of roller pairs.

Each roller arrangement 24 comprises a roller holder 27 which are [sic] arranged on the outer lateral surface of an essentially tubular segment 4' of the bottom drill-string part 7. Bores for receiving roller shafts 29 are made in the roller holder 27 corresponding to the alignment and number of rollers 28 belonging to a roller arrangement 24. In this case, the bores are arranged such that the axes of rotation S are located essentially outside the cross section of the bottom drill-string part 7, but the rollers 28 project, through openings 30, into the inner cross section of



the segment 4', with the result that the running surfaces 31 of the rollers are aligned in a manner corresponding to the outer surfaces of the angle profiles 22 and, when the drill-string parts 6, 7 have
5 been pushed one inside the other, roll on the outer surfaces of the angle profiles.

This type of mounting ensures low-friction displaceability of the top and of the bottom drill-string parts in the longitudinal direction
10 relative to one another, while at the same time it is possible to transmit high reaction torques about the longitudinal center axis L.

The overburden is delivered from the bottom of the bore hole to the platform by the known air-lift
15 method (not illustrated in the drawing), in the case of which air is blown into the interior of the drill string via a corresponding feed line.

In order to prevent the sediment which passes into the drill string from penetrating into the
20 mounting between the top and bottom drill-string parts 6, 7 and obstructing the capacity of the parts for low-friction movement relative to one another, an inner tube 36 ("rapier tube") is flanged - as can be seen from Figure 6 - at the bottom end of the top
25 drill-string part, which projects into the bottom drill-string part 7, said inner tube projecting into that part of the bottom drill-string part 7 which is located beneath it and terminating in an open state



just above the rotary drive 11. The bottom drill-string part 7 is of double-walled design in this region, the inner wall 47 being formed by an inner tube 48, of which the internal diameter is dimensioned such that a narrow annular gap 49 is formed between said internal diameter and the external diameter of the inner tube 46.

5 By virtue of this measure, the loosened sediment penetrates into the interior of the top drill-string part through the bottom opening of the inner tube 36, as a result of the negative pressure which prevails in the inner volume of the top drill-string part by virtue of the air-lift method being used, with the result that even at this stage said sediment cannot come into contact with the roller arrangements 24 or angle profiles 22.

10 Furthermore, the negative pressure which prevails in the interior of the top drill-string part 6 means that there is always a certain quantity of surrounding water which is sucked in through the annular gap 49, from the top end of the bottom drill-string part 7 and circulates around the roller arrangement 24 and the angle profiles 22, with the result that any fractions of sediment which may have penetrated are always washed out.

15 Although the invention has been described with reference to specific examples it will be appreciated to those skilled in the art that the invention may be embodied in many other forms.

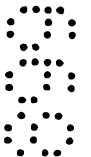
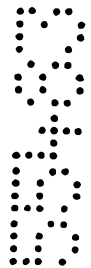
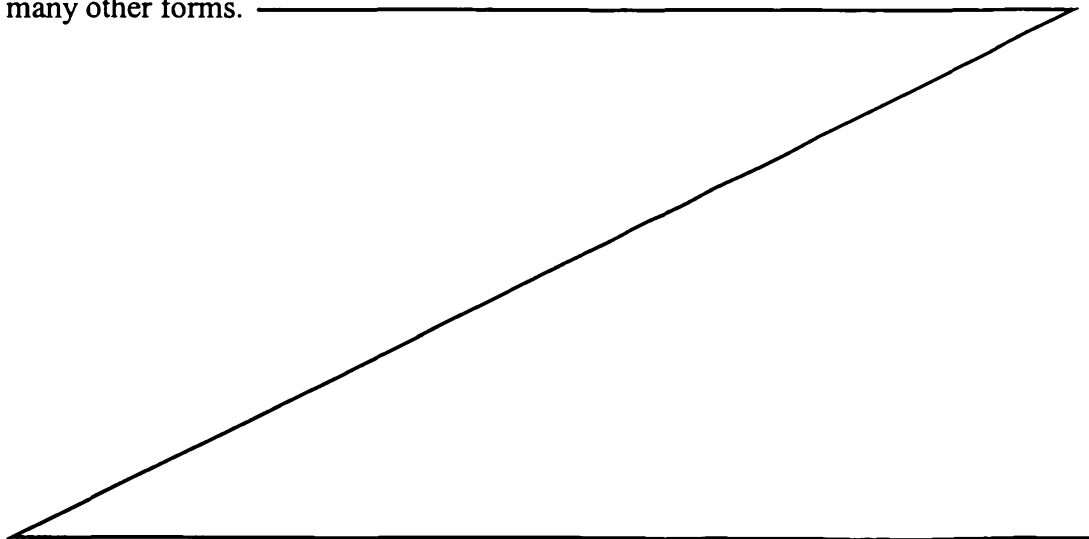

THE CLAIMS DEFINING THE INVENTION ARE AS FOLLOWS :

1. Method of sinking bore holes, in particular exploratory and extraction bore holes, in the sea bed, in the case of which method the latter is loosened with the aid of a rotating drill head which is arranged at the bottom end of a drill string which is suitable
5 for transmitting a torque and of which the top end is mounted on a floating platform, it being the case that the drill string comprises at least two telescopically interengaging drill-string parts which, during a vertical movement of the platform, induced for example by the sea swell, execute a movement relative to one another, with the result that the drill head rests with an essentially constant force on the surface which is to be cleared away,
10 wherein material from the sea bed which has been loosened is delivered out of the bore hole, through the interior of the drill string, by using the air-lift method.
2. Method according to Claim 1, wherein the drill head is arranged in a rotationally fixed manner on the drill string and, in order to produce the rotation of the drill head, the drill string is made to rotate with the aid of a rotary drive provided on the platform.
- 15 3. Method according to Claim 1, wherein the drill string is arranged in a rotationally fixed manner on the platform and the drill head is made to rotate relative to the drill string.
4. Apparatus for sinking bore holes, in particular exploratory and extraction bore holes, in the sea bed, having a drill string which is suitable for transmitting a torque and
20 of which the top end is mounted on a floating platform and of which the bottom end bears a rotationally driveable drill head and which comprises a plurality of drill-string parts which can be displaced with low friction in the axial direction of the drill string relative to one another, wherein there is provided an air inlet which is in connection with



the drill-string interior and through which it is possible to blow in compressed air fed via a pressure line.

5. Apparatus according to Claim 4, wherein the drill string comprises an outer and an inner drill-string part it being the case that the inner drill-string part engages in the outer drill-string part, at least over a length which corresponds to the maximum upward vertical movements of the platform which are to be expected as a result of sea swell or the like, and can be displaced further into the outer drill-string part, at least by an amount which corresponds to the maximum expected downward deflection of the platform out of its normal position.

10 6. Apparatus according to Claim 5, wherein the inner drill-string part comprises, at least over the maximum length by which it projects into the outer drill-string part, rails, which are distributed over its outer circumference and on which there run sliding elements, which are distributed correspondingly over the inner circumference of the outer drill-string part.

15 7. Apparatus according to Claim 6, wherein the sliding elements are rollers, the inner drill-string part is of tubular design and the rails comprise angle profiles which run in the direction of the longitudinal axis of the inner drill-string part and are welded on the outer surface of the inner drill-string part by way of their free longitudinal edges.

8. Apparatus according to Claim 7, wherein the outer drill-string part comprises, in the longitudinal direction of the same, at least one running-roller pair, which is arranged such that the two rollers of the running-roller pair are each assigned to an outer surface of an angle profile and are supported with rolling action on the same.



9. Apparatus according to Claim 8, wherein each of the angle profiles comprises two legs which are at right angles with respect to one another, and each angle profile is assigned at least two longitudinally spaced-apart roller pairs each running on one leg outer surface.

5 10. Apparatus according to Claim 9, wherein the outer drill-string part is of tubular design and comprises roller holders which are fastened on its outer circumference and each receive at least one roller, such that the roller's axis of rotation is located outside the cross section of the outer drill-string part and the roller's running surface projects, through a cutout made in the outer drill-string part, into the inner cross section of the
10 outer drill-string part.

11. Apparatus according to any one of Claims 5 to 10, wherein the inner drill-string part is mounted on the platform by way of its top end, and the outer drill-string part bears the drill head at its bottom end.

12. Apparatus according to any one of Claims 5 to 11, wherein arranged on the
15 platform is an arrangement for making the drill string rotate about its longitudinal axis, and the drill head is arranged in a rotationally fixed manner on the drill string.

13. Apparatus according to any one of Claims 5 to 11, wherein the drill string is mounted in a rotationally fixed manner on the platform and there is provided a rotary drive, with the aid of which the drill head can be made to rotate with respect to the drill
20 string.

14. Apparatus according to Claim 13, wherein serving for mounting the drill string on the platform is a cardanic retaining means.



15. Apparatus according to Claim 14 wherein said cardanic retaining means is a gimbal which is configured in two parts.

16. Apparatus according to any one of Claims 13 to 15, wherein the rotary drive is operated electrically.

5 17. Apparatus according to any one of Claims 13 to 15, wherein the rotary drive is operated hydraulically.

18. Apparatus according to any one of Claims 4 to 17, wherein the pressure line for blowing the compressed air into the interior of the drill string is secured on the outer circumference of the drill string and runs parallel to the longitudinal center axis thereof.

10 19. Apparatus according to any one of Claims 4 to 18, wherein the pressure line provided is a pressure hose which can be unrolled from a winding drum.

20. Apparatus according to any one of Claims 4 to 19, wherein a buoyancy unit is arranged on the drill-string part which bears the drill head.

15 21. Apparatus according to Claim 19, wherein the buoyancy unit is arranged in the vicinity of the top end of the bottom drill-string part.

22. Apparatus according to Claim 20 or 21, wherein the buoyancy unit comprises at least one tank which may optionally be filled with compressed air.

20 23. Apparatus according to any one of Claims 4 to 22, wherein at least one buoyancy element is provided on the drill-string part of which the top end is mounted on the platform.

24. A method of sinking bore holes in the sea bed substantially as herein described with reference to any one of the embodiments of the invention illustrated in the accompanying drawings.



25. An apparatus for sinking bore holes in the sea bed substantially as herein described with reference to any one of the embodiments of the invention illustrated in the accompanying drawings.

DATED this 9th day of August 1999.

5 WIRTH MASCHINEN-UND BOHRGERATE-FABRIK GmbH.

Attorney: CAROLINE M. BOMMER
Fellow Institute of Patent Attorneys of Australia
of BALDWIN SHELSTON WATERS

2
5

8

9



Fig. 1

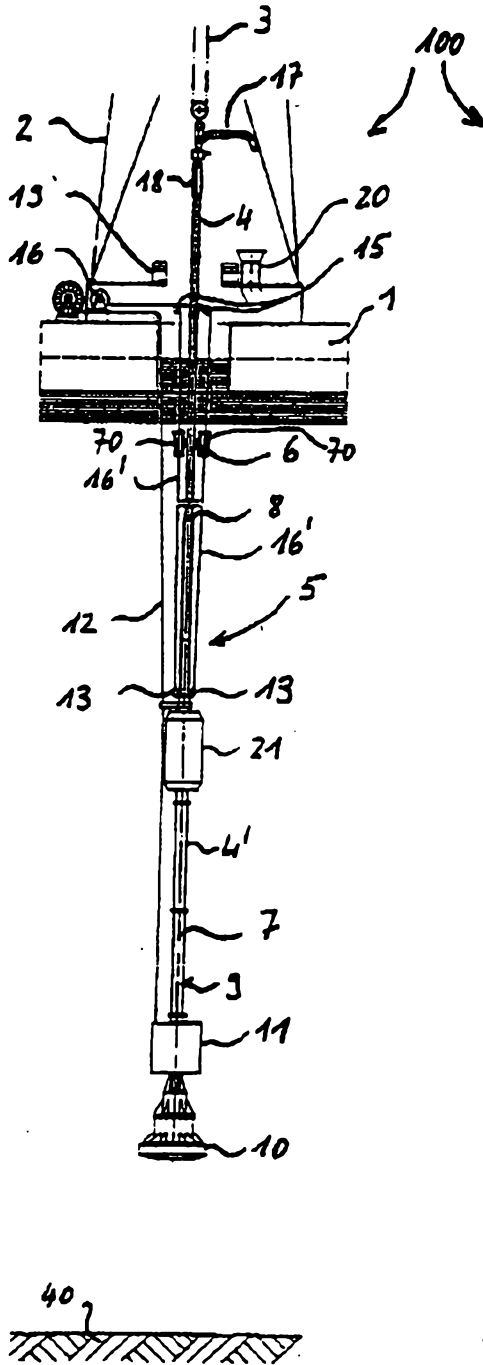

Fig. 2

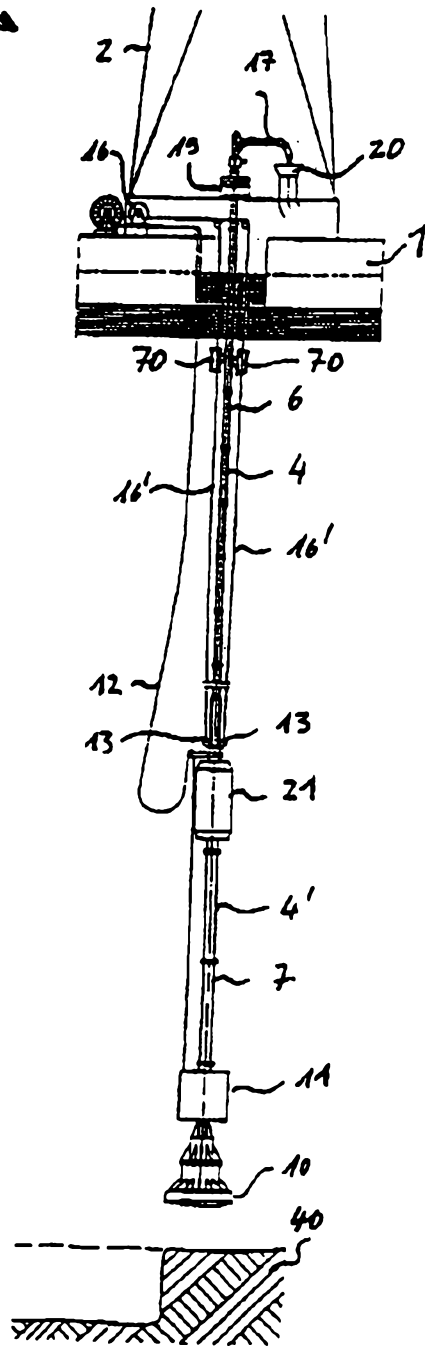
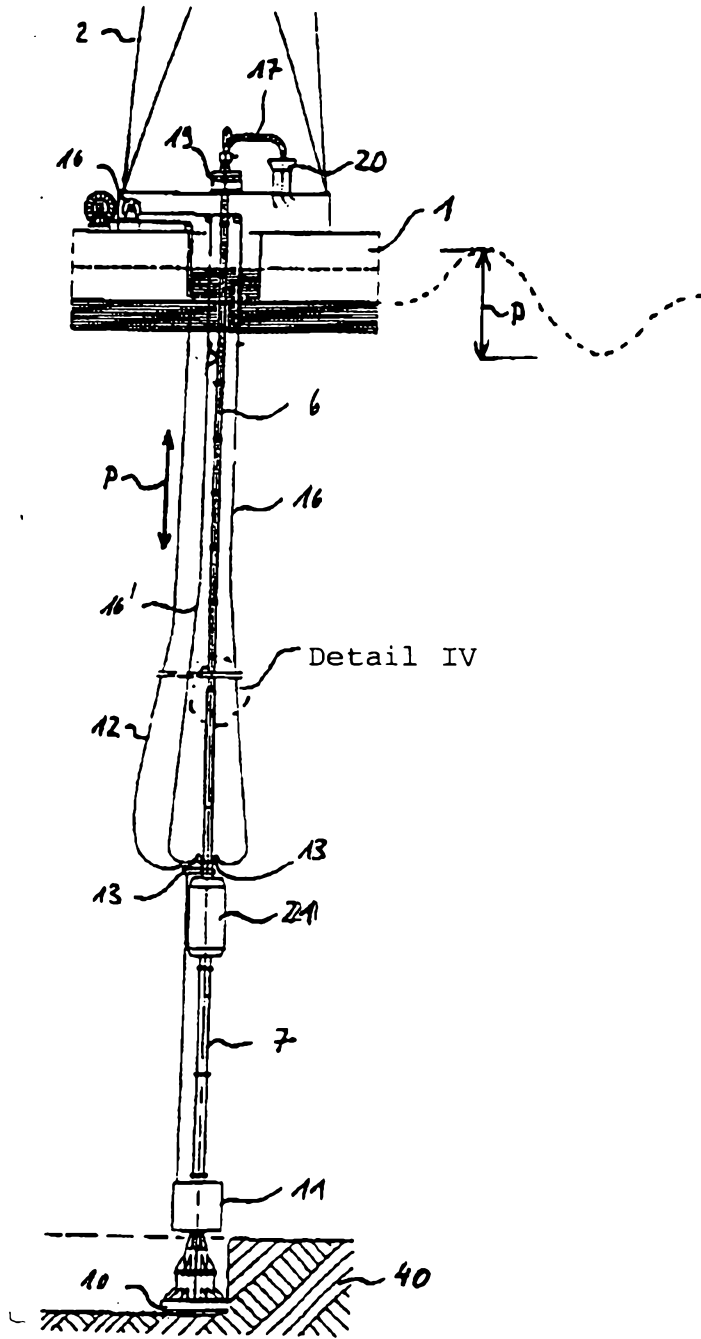

Fig. 3



4/4

Fig. 6

