

(19) World Intellectual Property Organization
International Bureau



(43) International Publication Date
30 October 2003 (30.10.2003)

PCT

(10) International Publication Number
WO 03/089814 A1

(51) International Patent Classification⁷: F16H 55/30

(21) International Application Number: PCT/US03/11744

(22) International Filing Date: 15 April 2003 (15.04.2003)

(25) Filing Language: English

(26) Publication Language: English

(30) Priority Data:
10/123,940 16 April 2002 (16.04.2002) US

(71) Applicant: CLOYES GEAR AND PRODUCTS, INC.
[US/US]; Suite 235, 8500 Station Street, Mentor, OH 44060 (US).

(72) Inventor: YOUNG, James, D.; 9394 Deitering Road, Chesaning, MI 48616 (US).

(74) Agent: HAAS, Steven, M.; Fay, Sharpe, Fagan, Minnich & McKee, LLP, 1100 Superior Avenue, Seventh Floor, Cleveland, OH 44114-2579 (US).

(81) Designated States (*national*): AE, AG, AL, AM, AT, AU, AZ, BA, BB, BG, BR, BY, BZ, CA, CH, CN, CO, CR, CU, CZ, DE, DK, DM, DZ, EC, EE, ES, FI, GB, GD, GE, GH, GM, HR, HU, ID, IL, IN, IS, JP, KE, KG, KP, KR, KZ, LC, LK, LR, LS, LT, LU, LV, MA, MD, MG, MK, MN, MW, MX, MZ, NO, NZ, OM, PH, PL, PT, RO, RU, SC, SD, SE, SG, SK, SL, TJ, TM, TN, TR, TT, TZ, UA, UG, UZ, VC, VN, YU, ZA, ZM, ZW.

(84) Designated States (*regional*): ARIPO patent (GH, GM, KE, LS, MW, MZ, SD, SL, SZ, TZ, UG, ZM, ZW), Eurasian patent (AM, AZ, BY, KG, KZ, MD, RU, TJ, TM), European patent (AT, BE, BG, CH, CY, CZ, DE, DK, EE, ES, FI, FR, GB, GR, HU, IE, IT, LU, MC, NL, PT, RO, SE, SI, SK, TR), OAPI patent (BF, BJ, CF, CG, CI, CM, GA, GN, GQ, GW, ML, MR, NE, SN, TD, TG).

Published:

- with international search report
- before the expiration of the time limit for amending the claims and to be republished in the event of receipt of amendments

For two-letter codes and other abbreviations, refer to the "Guidance Notes on Codes and Abbreviations" appearing at the beginning of each regular issue of the PCT Gazette.

(54) Title: ROLLER CHAIN SPROCKET WITH SYMMETRIC CUSHION RINGS

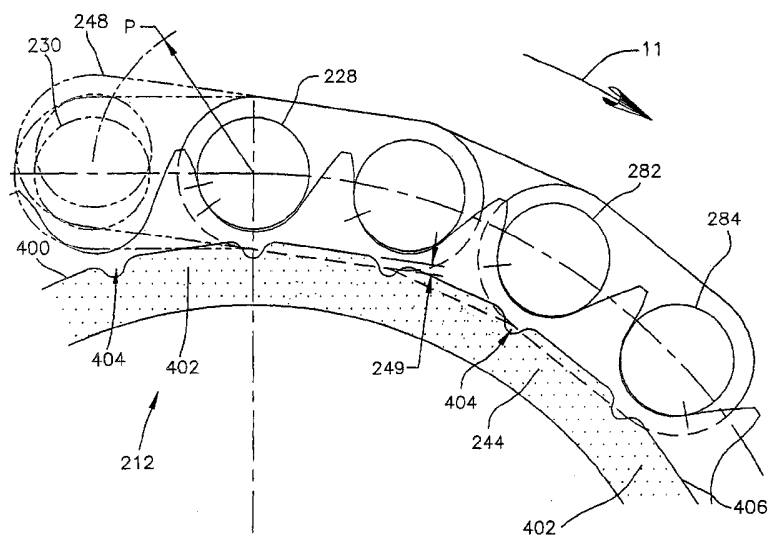

(57) Abstract: A sprocket (212) includes a hub and a plurality of teeth projecting radially outwardly from the hub. At least one cushion ring (244) is located adjacent the teeth, and the cushion ring defines a plurality of compression pads (402) separated from each other by transverse grooves (404). Each of the compression pads is defined symmetrically about a circumferential mid-point. When part of a sprocket with symmetric tooth spaces, the cushion ring is being operable identically in first and second opposite rotational directions. In one arrangement, the compression pads each include a planar outer surface having a leading and a trailing end, wherein the leading end and trailing end are located a common radial distance from a center of the hub about which the sprocket rotates. The tooth spaces of the sprocket can be symmetric, asymmetric and the root surface can be relieved. The sprocket can include multiple tooth profiles distributed randomly about the hub.



WO 03/089814 A1

ROLLER CHAIN SPROCKET WITH SYMMETRIC CUSHION RINGS

5

Cross Reference to Related Applications

This application claims priority from U.S. application serial number 09/728,698 filed December 1, 2000, now U.S. Patent No. 6,371,875, which claims priority
10 from U.S. application serial number 09/383,128 filed August 25, 1999, now U.S. Patent No. 6,179,741, which claims priority from U.S. provisional application serial number 60/097,931 filed August 25, 1998.

15

Background of the Invention

The present invention relates to the automotive timing chain art. It finds particular application in conjunction with a roller chain sprocket for use in automotive camshaft drive applications and will be
20 described with particular reference thereto. However, the present invention may also find application in conjunction with other types of chain drive systems and applications where reducing the noise levels associated with chain drives is desired.

25

Roller chain sprockets for use in camshaft drives of automotive engines are typically manufactured according to one or more international standards such as DIN, JIS, ISO, etc. The ISO-606:1994(E) (International Organization for Standardization) standard specifies requirements for
30 short-pitch precision roller chains and associated chain wheels or sprockets.

Figure 1 illustrates a symmetrical tooth space form for an ISO-606 compliant sprocket. The tooth space has a continuous fillet or root radius R_i extending from one tooth flank (i.e., side) to the adjacent tooth flank as defined by the roller seating angle α . The flank radius R_f is tangent to the roller seating radius R_i at the tangency point TP. A chain with a link pitch P has rollers of diameter D_1 in contact with the tooth spaces. The ISO sprocket has a chordal pitch also of length P , a root diameter D_2 , and Z number of teeth. The pitch circle diameter PD , tip or outside diameter OD , and tooth angle A (equal to $360^\circ/Z$) further define the ISO-606 compliant sprocket. The maximum and minimum roller seating angle α is defined as:

15

$$\alpha_{\max} = 140^\circ - (90^\circ/Z) \quad \text{and} \quad \alpha_{\min} = 120^\circ - (90^\circ/Z)$$

With reference to Figure 2, an exemplary ISO-606 compliant roller chain drive system 10 rotates in a clockwise direction as shown by arrow 11. The chain drive system 10 includes a drive sprocket 12, a driven sprocket 14 and a roller chain 16 having a number of rollers 18. The sprockets 12, 14, and chain 16 each generally comply with the ISO-606 standard.

25

The roller chain 16 engages and wraps about sprockets 12 and 14 and has two spans extending between the sprockets, slack strand 20 and taut strand 22. The roller chain 16 is under tension as shown by arrows 24. A central portion of the taut strand 22 may be guided between the driven sprocket 14 and the drive sprocket 12 with a conventional chain guide (not shown). A first roller 28 is shown at the onset of meshing at a 12 o'clock position on the drive sprocket 12. A second roller 30 is adjacent to

30

the first roller 28 and is the next roller to mesh with the drive sprocket 12.

Chain drive systems have several components of undesirable noise. A major source of roller chain drive noise is the sound generated as a roller leaves the span and collides with the sprocket during meshing. The resultant impact noise is repeated with a frequency generally equal to that of the frequency of the chain meshing with the sprocket. The loudness of the impact noise is a function of the impact energy (E_A) occurring during the meshing process. The impact energy (E_A) is related to engine speed, chain mass, and the impact velocity between the chain and the sprocket at the onset of meshing. The impact velocity is affected by the chain-sprocket engagement geometry, of which an engaging flank pressure

$$E_A = \frac{wP}{2000} V_A^2 ;$$

$$V_A = \frac{\pi n P}{30000} \sin\left(\frac{360}{Z} + \gamma\right);$$

$$\gamma = \frac{180 - A - \alpha}{2}; \text{and}$$

angle γ (Fig. 3) is a factor, where:

	E_A	=	Impact Energy [N·m]
	V_A	=	Roller Impact Velocity [m/s]
	γ	=	Engaging Flank Pressure Angle
20	n	=	Engine Speed [RPM]
	w	=	Chain Mass [Kg/m]
	Z	=	Number of Sprocket Teeth
	A	=	Tooth Angle ($360^\circ/Z$)
	α	=	Roller Seating Angle
25	P	=	Chain Pitch (Chordal Pitch)

The impact energy (E_A) equation presumes the chain drive kinematics will conform generally to a quasi-static analytical model and that the roller-sprocket driving contact will occur at a tangent point TP (Fig. 3) of the flank and root radii as the sprocket collects a roller from the span.

As shown in Figure 3, the pressure angle γ is defined as the angle between a line A extending from the center of the engaging roller **28**, when it is contacting the engaging tooth flank at the tangency point TP, through the center of the flank radius R_f , and a line B connecting the centers of the fully seated roller **28**, when it is seated on root diameter D_2 , and the center of the next meshing roller **30**, as if it were also seated on root diameter D_2 in its engaging tooth space. The roller seating angles α and pressure angles γ listed in Figure 4 are calculated from the equations defined above. It should be appreciated that γ is a minimum when α is a maximum. Thus, the exemplary 23-tooth, ISO-606 compliant, drive sprocket **12** shown in Figures 2 and 3 will have a pressure angle γ in the range of 14.13° to 24.13° as listed in the table of Figure 4.

Figure 3 also shows the engagement path (phantom rollers) and the driving contact position of roller **28** (solid) as the drive sprocket **12** rotates in the direction of arrow **11**. Figure 3 depicts the theoretical case with chain roller **28** seated on root diameter D_2 of a maximum material sprocket with both chain pitch and sprocket chordal pitch equal to theoretical pitch P . For this theoretical case, the noise occurring at the onset of roller engagement has a radial component F_R as a result of roller **28** colliding with the root surface R_i and a tangential component F_T generated as the same roller **28** collides with the engaging tooth flank at point TP as the

roller moves into driving contact. It is believed that the radial impact occurs first, with the tangential impact following nearly simultaneously. Roller impact velocity V_A is shown to act through, and is substantially normal to, engaging flank tangent point TP with roller 28 in driving contact at point TP.

The impact energy (E_A) equation accounts only for a tangential roller impact during meshing. The actual roller engagement, presumed to have a tangential and radial impact (occurring in any order), would therefore seem to be at variance with the impact energy (E_A) equation. The application of this quasi-static model, which is beneficially used as a directional tool, permits an analysis of those features that may be modified to reduce the impact energy occurring during the tangential roller-sprocket collision at the onset of meshing. The radial collision during meshing, and its effect on noise levels, can be evaluated apart from the impact energy (E_A) equation.

Under actual conditions as a result of feature dimensional tolerances, there will normally be a pitch mismatch between the chain and sprocket, with increased mismatch as the components wear in use. This pitch mismatch serves to move the point of meshing impact, with the radial collision still occurring at the root surface R_i but not necessarily at D_2 . The tangential collision will normally be in the proximity of point TP, but this contact could take place high up on the engaging side of root radius R_i or even radially outward from point TP on the engaging flank radius R_f as a function of the actual chain-sprocket pitch mismatch.

Reducing the engaging flank pressure angle γ reduces the meshing noise levels associated with roller chain drives, as predicted by the impact energy (E_A) equation set forth above. It is feasible but not

recommended to reduce the pressure angle γ while maintaining a symmetrical tooth profile, which could be accomplished by simply increasing the roller seating angle α , effectively decreasing the pressure angle for both flanks. This profile as described requires that a worn chain would, as the roller travels around a sprocket wrap (discussed below), interface with a much steeper incline and the rollers would necessarily ride higher up on the coast flank prior to leaving the wrap.

Another source of chain drive noise is the broadband mechanical noise generated in part by shaft torsional vibrations and slight dimensional inaccuracies between the chain and the sprockets. Contributing to a greater extent to the broadband mechanical noise level is the intermittent or vibrating contact that occurs between the unloaded rollers and the sprocket teeth as the rollers travel around the sprocket wrap. In particular, ordinary chain drive system wear comprises sprocket tooth face wear and chain wear. The chain wear is caused by bearing wear in the chain joints and can be characterized as pitch elongation. It is believed that a worn chain meshing with an ISO standard sprocket will have only one roller in driving contact and loaded at a maximum loading condition.

With reference again to Figure 2, driving contact at maximum loading occurs as a roller enters a drive sprocket wrap **32** at engagement. Engaging roller **28** is shown in driving contact and loaded at a maximum loading condition. The loading on roller **28** is primarily meshing impact loading and the chain tension loading. The next several rollers in the wrap **32** forward of roller **28** share in the chain tension loading, but at a progressively decreasing rate. The loading of roller **28** (and to a lesser extent for the next several rollers in the wrap) serves to

maintain the roller in solid or hard contact with the sprocket root surface 34.

A roller 36 is the last roller in the drive sprocket wrap 32 prior to entering the slack strand 20. Roller 36 is also in hard contact with drive sprocket 12, but at some point higher up (e.g., radially outwardly) on the root surface 34. With the exception of rollers 28 and 36, and the several rollers forward of roller 28 that share the chain tension loading, the remaining rollers in the drive sprocket wrap 32 are not in hard contact with the sprocket root surface 34, and are therefore free to vibrate against the sprocket root surfaces as they travel around the wrap, thereby contributing to the generation of unwanted broadband mechanical noise.

A roller 38 is the last roller in a sprocket wrap 40 of the driven sprocket 14 before entering the taut strand 22. The roller 38 is in driving contact with the sprocket 14. As with the roller 36 in the drive sprocket wrap 32, a roller 42 in the sprocket wrap 40 is in hard contact with a root radius 44 of driven sprocket 14, but generally not at the root diameter.

It is known that providing pitch line clearance (PLC) between sprocket teeth promotes hard contact between the chain rollers and sprocket in the sprocket wrap, even as the roller chain wears. The amount of pitch line clearance added to the tooth space defines a length of a short arc that is centered in the tooth space and forms a segment of the root diameter D_2 . The root fillet radius R_1 is tangent to the flank radius R_F and the root diameter arc segment. The tooth profile is still symmetrical, but R_1 is no longer a continuous fillet radius from one flank radius to the adjacent flank radius. This has the effect of reducing the broadband mechanical noise component of a

chain drive system. However, adding pitch line clearance between sprocket teeth does not reduce chain drive noise caused by the roller-sprocket collision at impact.

Another attempt to reduce the noise levels associated with roller chain meshing is described in U.S. Patent No. 5,397,278 which discloses the undercutting or relieving of the root surfaces so as to eliminate the radial roller-root surface contact at the onset of meshing.

However, the invention disclosed in the '278 patent does not modulate the meshing impact frequency. That is, all of the tooth profiles are substantially identical. Therefore, the flank impacts occur at the meshing frequency. An additional disadvantage of the sprocket disclosed in the '278 patent is that the rollers contact both engaging and disengaging flanks at full mesh. Thus, a roller can become wedged within the tooth space when no clearance is provided between the roller and a disengaging flank with the roller seated in full mesh.

A further attempt to reduce the noise levels associated with roller chain meshing is to incorporate one or more elastomeric cushion rings that serve to buffer or soften the engaging impact of a roller as it leaves the span and collides with a sprocket during the meshing process. With reference to Figure 6, a drive sprocket **112**, associated with a conventional roller chain drive system **110**, incorporates symmetrical, ISO-606 compliant tooth space profiles. The drive sprocket **112** is substantially identical to the drive sprocket **12** (Fig. 2) except that the drive sprocket **112** includes two circular cushion rings **144**, one secured on each hub of the sprocket **112**. Each cushion ring **144** has a continuous or otherwise uniform outer surface that is defined by a radius **R**. As is known in the art, the cushion rings **144** serve to buffer or soften the

engaging impact of a roller as it leaves the span and collides with a sprocket during the meshing process.

More particularly, as shown in Figures 6a and 6b, a roller 128, a bushing 129, and an associated pin 131, are carried by two sets of overlapping link plates 146L, 146R and 148L, 148R. As the drive sprocket 112 rotates in the direction of arrow 11, the link plates 146 impact, and then compress or otherwise deform, the outer surfaces of both cushion rings 144 prior to roller 128 colliding with the associated sprocket tooth, followed consecutively by the link plates 148. As a result, the impact velocity of the roller 128 is reduced prior to meshing with the sprocket, thereby reducing meshing impact noise. The maximum amount of cushion ring compression 149 occurs close to, or at, the midpoint $P/2$ between adjacent rollers having a chain pitch P . Figure 6b shows the rubber compression to alternate in consecutive pitches between link plates 146 and link plates 148. A typical problem with cushion rings is one of durability. That is, wear and compression set of the elastomeric material of the cushion rings can be expected in the area of maximum ring compression after repeated link impacts. In addition, the cushion ring may eventually fatigue as a result of the repeated compression cycles during the meshing process.

Accordingly, it is considered desirable to develop a new and improved roller chain drive system and sprocket which meets the above-stated needs and overcomes the foregoing disadvantages and others while providing better and more advantageous results.

30

Summary of the Invention

In accordance with one aspect of the present development, a sprocket includes a hub and a plurality of

teeth projecting radially outwardly from the hub. At least one cushion ring is located adjacent the teeth, and the cushion ring defines a plurality of compression pads separated from each other by transverse grooves. Each of
5 the compression pads is defined symmetrically about a circumferential mid-point.

In accordance with another aspect of the present development, a sprocket comprises a hub and a plurality of teeth that project radially outwardly from the hub. At
10 least one cushion ring is located adjacent the teeth. The cushion ring defines a symmetrical outer surface that comprises a plurality of axially extending grooves defined therein.

In accordance with another aspect of the present
15 development, a sprocket comprises a hub and a plurality of teeth projecting radially outwardly from the hub. At least one cushion ring is located adjacent the teeth and comprises a plurality of compression pads separated from each other by grooves. The cushion ring is being operable
20 identically in first and second opposite rotational directions.

In accordance with a further aspect of the present development, a sprocket comprises a hub and a plurality of teeth projecting radially outwardly from the
25 hub. At least one cushion ring is located adjacent the teeth, and the cushion ring defines a plurality of compression pads separated from each other by transverse grooves. Each of the compression pads comprises an outer surface having a leading end and a trailing end located a
30 common radial distance from a center of the hub about which the sprocket rotates.

One advantage of the present invention is the provision of a sprocket that includes at least one cushion

ring designed to increase the fatigue life of the elastomeric material that forms the cushion ring.

Another advantage of the present invention is the provision of a sprocket having two sets of sprocket teeth incorporating different tooth profiles, and at least one cushion ring that cooperates with the tooth profiles to reduce chain drive system noise levels below a noise level that either the tooth profiles or the cushion ring alone would produce.

Another advantage of the present invention is the provision of a sprocket having two different sets of asymmetrical sprocket teeth each incorporating root relief.

Another advantage of the present invention is the provision of a sprocket that phases or modulates the frequency of initial roller-to-engaging flank contacts of a first tooth profile relative to initial roller-to-engaging flank contacts of a second tooth profile thereby altering the rhythm of the initial roller-to-first engaging flank and the roller-to-second engaging flank contacts.

Yet another advantage of the present invention is the provision of a sprocket that minimizes impact noise generated by a roller-sprocket collision during meshing and/or broadband mechanical noise generated by unloaded rollers in a sprocket wrap.

A still further advantage of the present invention is the provision of a sprocket that provides a "staged" roller impact (i.e., an extension of the roller meshing interval) where a tangential roller-sprocket impact occurs first followed by a radial roller-sprocket impact at full mesh.

Yet a further advantage of the present invention is the provision of a sprocket that spreads a roller engagement over a significant time interval to provide for

a more gradual load transfer thereby minimizing a roller-sprocket impact and the inherent noise generated therefrom.

A still further advantage of the present invention resides in the provision of a sprocket including
5 symmetrical tooth spaces including root relief and cushion rings whereby rollers of an associated roller chain are spaced from the relieved root surfaces in the respective tooth spaces when the rollers are fully seated in the respective tooth spaces.

10 Still further advantages of the present invention will become apparent to those of ordinary skill in the art upon reading and understanding the following detailed description of the preferred embodiments.

15 **Brief Description of the Drawings**

The invention may take form in various components and arrangements of components, and in various steps and arrangements of steps. The drawings are only for purposes of illustrating the preferred embodiments and are not to be
20 construed as limiting the invention.

Figure 1 illustrates a symmetrical tooth space form for an ISO-606 compliant roller chain sprocket;

Figure 2 is an exemplary roller chain drive system having an ISO-606 compliant drive sprocket, driven
25 sprocket, and roller chain;

Figure 3 is an enlarged partial view of the drive sprocket of Figure 2 showing an engagement path (phantom) and a roller (solid) in a driving position as the drive sprocket rotates in a clockwise direction;

30 Figure 4 is a table listing roller seating angles α and pressure angles γ for a number of different ISO-606 compliant sprocket sizes;

Figure 5 is a table listing the maximum Beta (β) angles and the corresponding pressure angles (γ) for three

different asymmetrical tooth space profiles (1-3) of varying sprocket sizes of the present invention;

Figure 6 illustrates an exemplary ISO-606 compliant drive sprocket incorporating a conventional cushion or damper ring on each face thereof;

Figure 6a is an enlarged partial view of the drive sprocket of Figure 6 showing the interaction between a roller chain link plate and the cushion ring;

Figure 6b is a cross section view through the roller chain link plate taken along the line 6b-6b in Figure 6a;

Figure 7 illustrates an exemplary roller chain drive system that incorporates the features of the present invention therein;

Figure 8 illustrates a random-engagement roller chain drive sprocket of the drive system of Figure 7;

Figure 8a is a cross section view through the sprocket taken along the line 8a-8a of Figure 8;

Figure 9 illustrates a first asymmetrical tooth space profile for the sprocket of Figure 8;

Figure 9a is an enlarged partial view of an engaging flank of the first asymmetrical tooth space profile of Figure 9 with a roller fully seated in two-point contact;

Figure 9b is an enlarged partial view of the first asymmetrical tooth space profile of Figure 9 showing a roller fully seated in two-point mesh;

Figure 9c is an enlarged partial view of the first asymmetrical tooth space profile of Figure 9 showing a roller seated at the lower flank Points S and S;

Figure 10 illustrates a second asymmetrical tooth space profile for the sprocket of Figure 8;

Figure 11 illustrates the asymmetrical tooth profile of Figure 9 overlaid with the asymmetrical tooth profile of Figure 10;

Figure 12 is an enlarged partial view of the
5 random-engagement roller chain drive sprocket of Figure 7 at the taut strand-sprocket interface; and

Figure 12a is an enlarged partial view of the random-engagement roller chain drive sprocket of Figure 8;

Figure 12b is an enlarged partial view of the
10 sprocket Figure 12a illustrating the positional relationship between the sprocket tooth spaces and the cushion ring pads and grooves;

Figure 12c is an enlarged partial view of the sprocket of Figure 12;

Figure 12d is an enlarged partial view of the
15 sprocket of Figure 12;

Figure 12e is an enlarged partial view of the sprocket of Figure 12d; and

Figure 13a is an enlarged partial view of an ISO-
20 606 compliant sprocket illustrating the relationship between the ISO-606 compliant sprocket tooth spaces and the cushion ring pads and grooves of the present invention;

Figure 13b is an enlarged partial view of an ISO-
606 compliant sprocket that incorporates root relief and
25 that includes a cushion ring formed in accordance with the present invention;

Figure 14 illustrates the sprocket of Figure 13b and shows a preferred cushion ring conformation and location where each compression pad comprises a planar
30 surface that is parallel to a chord or line segment that extends between the centers of two adjacent rollers when the rollers are both fully seated in their respective tooth spaces and located adjacent opposite ends of the compression pad.

Detailed Description of the Preferred Embodiments

This invention relates to sprockets having symmetric and/or asymmetric teeth or tooth spaces, and also
5 relates to sprockets having multiple arbitrarily positioned asymmetric tooth profiles (referred to herein as random engagement sprockets). In accordance with the present invention, any of these sprockets includes one or more cushion rings formed in accordance with the present
10 invention. Furthermore, the particular sprockets and tooth profiles described herein are intended to be examples of preferred embodiments, and it is not intended that the invention be limited to these preferred embodiments in any way.

15 With reference now to Figure 7, a roller chain drive system 210 that incorporates the features of the present invention therein. The roller chain drive system 210 includes a random-engagement drive sprocket 212, a driven sprocket 214, and a roller chain 216 having a number
20 of rollers 218 which engage and wrap about sprockets 212, 214. The sprockets 212, 214 rotate in a clockwise direction as shown by arrow 11.

The roller chain 216 has two spans extending between the sprockets, slack strand 220 and taut strand
25 222. The roller chain 216 is under tension as shown by arrows 224. A central portion of the taut strand 222 may be guided between the driven sprocket 214 and the drive sprocket 212 with a chain guide (not shown). A first roller 228 is shown fully seated at a 12 o'clock position on
30 the drive sprocket 212. A second roller 230 is adjacent to the first roller 228 and is the next roller to mesh with the drive sprocket 212.

To facilitate the description of an asymmetrical tooth profiles of the present invention, reference will be made only to the drive sprocket **212**. However, the asymmetrical tooth profiles of the present invention are
5 equally applicable to the driven sprocket **214**, as well as to other types of sprockets such as idler sprockets and sprockets associated with counter rotating balance shafts, etc.

With continuing reference to Figure 7 and
10 particular reference to Figures 8 and 8a, the random-engagement roller chain drive sprocket **212** is illustrated as a 23-tooth sprocket. However, the sprocket **212** may have more or less teeth, as desired. The sprocket **212** includes a central hub **213**, a first group of sprocket teeth **250** (not
15 individually numbered) and a second group of sprocket teeth **252** (individually numbered as sprocket teeth 1, 3, 8, 9, 10, 14, 17, 21, and 22) arbitrarily or non-regularly positioned around the circumference of the hub **213**. In the
illustrated embodiment being described, there are fourteen
20 sprocket teeth **250** and nine sprocket teeth **252** arbitrarily positioned around the sprocket **212**. However, it should be appreciated that the number and position of each type of sprocket tooth can vary without departing from the scope of the invention.

25 With reference now also to Figures 8 and 8a, the sprocket **212** includes two elastomeric cushion or damper rings **244** formed in accordance with the present invention.

The cushion rings **244** are secured or otherwise attached in a conventional manner to the hub **213** adjacent opposite
30 axial faces of the sprocket teeth, i.e., on opposite axial sides of the teeth **250,252**. In the preferred embodiment the cushion rings are formed from a conventional elastomeric material such as a Nitrile rubber compound, but

any other suitable resilient and durable material can be used without departing from the overall scope and intent of the present invention.

The two sets of sprocket teeth 250, 252 are
5 arranged in a random pattern in order to modify the meshing impact frequency by altering the point and rhythm of initial roller-to-sprocket contact. However, the two sets of sprocket teeth 250, 252 could be arranged in many different random patterns. Further, it is also
10 contemplated that the two sets of sprocket teeth 250, 252 could be arranged in many regular patterns that would work equally as well. In all cases, the arrangement of two sets of sprocket teeth on a sprocket provides a means for breaking-up or modulating the meshing frequency impact
15 noise normally associated with and induced by a full complement of substantially identically shaped sprocket teeth. The meshing frequency noise reduction is achieved, in part, by altering the point and rhythm of initial roller-to-sprocket contact.

20 With specific reference now to Figure 8, it can be seen that the sprocket teeth 250 each include an engaging side or flank profile that cooperates with a disengaging side or flank profile of an adjacent tooth (in a clockwise-manner) to form a first asymmetrical tooth
25 space 254 having a root surface 256. The numbered sprocket teeth 252 each include an engaging side or flank profile that cooperates with a disengaging side or flank profile of an adjacent tooth (in a clockwise-manner) to form a second asymmetrical tooth space 258 having a root surface 260. As
30 described further below, the first and second groups of sprocket teeth 250, 252 cooperate with the cushion rings 244 to reduce chain drive system noise levels below a noise level which either tooth profile used alone would produce.

Referring now to Figures 9 through 9c, the sprocket 212 includes a first tooth 262 having an engaging side or flank 264, and a second tooth 266 having a disengaging side or flank 268. The engaging flank 264 and disengaging flank 268 cooperate to define one of the tooth spaces 254 for receiving a roller associated with the chain 216, such as roller 269. Thus, the sprocket tooth 262 is necessarily classified as one of the teeth 250, and the sprocket tooth 266 can be classified as either one of the sprocket teeth 250 or 252.

The engaging roller 269 has a roller diameter D_1 , and is shown fully seated in two-point contact within the tooth space 254. More particularly, the engaging roller 269 contacts two lines or ridges B and C that extend axially along the engaging flank surface or face (i.e. in a direction orthogonal to the plane of the drawings) when fully seated in driving contact within the tooth space 254.

However, to facilitate a description thereof, the lines or ridges B and C are hereafter shown and referred to as contact points within the tooth space.

The engaging flank 264 has a radius R_f that is tangent to a radially outer end of a flank flat 270. A first portion of the root surface 256, defined by radius R_i , is tangent to a radially inner end of the flank flat 270 at one end thereof, and tangent to a radially outer end of a first non-functional flat surface (not shown) that extends radially outward from Point C, at the other end thereof. As best shown in Figure 9a, a maximum value for the root radius R_i must be equal to, or less than, a minimum roller radius $0.5D_1$ in order to insure that two-point/line contact occurs at Points B and C. As a result of $R_i \leq 0.5D_1$, a small clearance 273 is defined between the root surface 256

and the roller 269 when the roller is seated at Points B and C.

A second non-functional flat surface (not shown) extends between Point B and a radially outer end of the root surface portion defined by radius R_i . The second non-functional flat surface is contiguous with the flank flat 270. That is, a first portion of the flank flat 270 extends radially outward from Point B to facilitate "staged" roller-sprocket meshing. A second, non-functional, portion of the flank flat 270 extends radially inward of Point B and cooperates with the first non-functional flat surface extending radially outward from Point C to facilitate the roller seating in two-point contact at Points B and C.

Referring again to Figure 9, the location of the flank flat 270 is determined by the angle β , with the flat orientation being normal or perpendicular to a line that passes through Point B and the center (Point X) of roller 269 when the roller is contacting the sprocket at Points B and C. The length of the flank flat portion that extends radially outward from Point B affects a time delay between an initial tangential impact between sprocket 212 and roller 269 at the first contact Point A along the flank flat 270, and a subsequent radial impact at Point C. It should be appreciated that the pressure angle γ (described further below), the amount of pitch mismatch between the chain and the sprocket, and the length of the flank flat can be varied to achieve a desired initial roller contact Point A at the onset of roller-sprocket meshing. It should also be appreciated that, under theoretical conditions, initial roller-sprocket contact occurs at Point B. However, for all other pitch mismatch conditions, the initial contact occurs at Point A, which is offset from Point B. Thus, for all but the theoretical condition, the

initial tangential contact occurs at Point A at the onset of mesh, with its related impact force F_T (Fig. 9b).

The roller 269 is believed to stay in hard contact with the flank flat 270 from Point A to Point B as the sprocket rotation moves the roller into full mesh with subsequent radial contact at Point C. The radial impact force F_R (Fig. 9b) does not occur until the sprocket has rotated sufficiently to bring roller 269 into radial contact at Point C. Thus, the radial impact force F_R occurs at the instant of full mesh. The force vector F_R is shown in solid to indicate the occurrence of the radial impact at Point C, and the tangential impact force vector F_T is shown in outline to indicate the previous occurrence of the tangential impact at Point A.

The taut strand load transfer to the meshing roller is considered to be complete at full mesh. At the instant of the radial collision by roller 269 at Point C, with its resultant radial impact force F_R , the tangential impact force of F_T has already occurred and is no longer a factor. The time delay ("staged" engagement) between the tangential and radial roller-sprocket collisions effectively spreads the impact energy occurring during the meshing process over a greater time interval, thereby reducing its contribution to the generated noise level at mesh frequency. Additionally, the present asymmetrical sprocket tooth profile beneficially permits a more gradual taut strand load transfer from a fully engaged roller to a meshing roller as the meshing roller moves from its Point A initial mesh to its full two-point mesh position at Points B and C.

Referring again to Figure 9, the root surface 256 incorporates root relief. That is, a second flat surface 272 extends radially inward from Point C. A second portion of the root surface 256, defined by the radius R_1' , is

tangent to a radially inner end of the flat surface 272 and is tangent to a radially inner end of a third flat surface 274. The disengaging flank 268, defined by the radius R_f' , is tangent to a radially outer end of the third flat surface 274.

It should be appreciated that the non-functional flat surface extending radially outward from Point C is contiguous with the flat surface 272. That is, a first portion of the flat surface 272 extends radially outward from Point C and cooperates with the second non-functional flat surface extending radially inward from Point B (associated with the flank flat 270) to cause the roller to seat in two-point contact at Points B and C. A second portion of the flat surface 272 extends radially inward of Point C and cooperates with the third flat surface 274 to provide root relief.

A clearance 276 exists between the roller 269 and the relieved root surface 256 when the roller 269 is seated in full mesh at Points B and C. For the root relieved tooth space 254, the roller 269 contacts point B at full mesh when its center is on the theoretical pitch diameter PD. The second root radius R_1' is necessarily equal to, or less than, one-half the diameter D_1 of roller 269. Figure 9b illustrates the roller clearance 278 to the disengaging flank 268 for the full mesh position of the roller 269 at points B and C.

With reference now to Figure 9c, root relief is defined herein as the clearance 280 that exists between the roller 269 and the relieved root surface 256 when the roller 269 bridges across the root and seats at points S and S' on the opposing engaging and disengaging flanks 264, 268, respectively. Thus, the roller 269 is prevented from contacting the root surface 256 when the sprocket 212

rotates to the point that the roller 269 bridges across the root and seats at points S and S' on the opposing engaging and disengaging flanks 264, 268, respectively. In particular, Figure 9c illustrates the point at which the roller 269 is moved radially inward from Point C and contacts the lower flanks at Points S and S' during rotation of the sprocket 212 around the sprocket wrap 232 (Fig. 7). It should be appreciated that, as the roller continues to travel around the sprocket wrap, the roller moves outward from Point S' along the disengaging flank 268.

In order for the roller 269 to advance into contact with the lower flanks at Points S and S', the roller must advance from the two-point full mesh position and move radially inward from the pitch circle diameter PD by a radial distance. If under some severe operating conditions, the chain drive dynamics force roller 269 to impact the lower flank surfaces of the tooth space 254, the roller is constrained by the meshing geometry which requires the roller to make its initial tangential contact with the sprocket tooth at Point A, then move to its full two-point mesh position at Points B and C before it can progress forward and radially inward to Points S and S', which also will require further compression of the cushion rings 244 (described further below) as the roller travels a radially inward path.

The meshing geometry for the present asymmetrical tooth profile, along with the favorable roller-sprocket seating geometry at Points S and S', provide a superior noise attenuation to that of the conventional ISO-606 rubber cushion ring system of Fig. 6. The impact vectors F_{IS} and $F_{IS'}$ (Fig. 9c) occur sequentially following the initial tangential contact and subsequent two-point

seating. The ISO-606 radial (root) impact vector F_R (Fig. 3), on the other hand, is believed to be the initial roller-sprocket impact before the roller then moves into driving position on the engaging flank.

5 The engaging flank roller seating angle β (Fig. 9) and a disengaging flank roller seating angle β' replace the ISO-606 roller seating angle α . The pressure angle γ is a function of the engaging flank roller seating angle β . That is, as β increases, γ decreases. A minimum asymmetrical
10 pressure angle can be determined from the following equation, where:

$$\gamma_{\min} = \beta_{\max} - (\alpha_{\max} / 2 + \gamma_{\text{ISO min}})$$

15 Therefore, an asymmetrical pressure angle $\gamma_{\min} = 0$ when $\beta_{\max} = (\alpha_{\max} / 2 + \gamma_{\text{ISO min}})$ as illustrated in the Table of Figure 5. Figure 5 lists the maximum Beta (β) angles and the corresponding pressure angles (γ) for several sprocket sizes and several asymmetrical profiles. It should be
20 appreciated that reducing the engaging flank pressure angle γ reduces the tangential impact force component F_T (Fig. 9b) and thus the tangential impact noise contribution to the overall noise level at the onset of engagement.

 The impact force F_T is a function of the impact
25 velocity which in turn is related to pressure angle γ . As pressure angle γ is reduced, it provides a corresponding reduction in the impact velocity between the chain and the sprocket at the onset of meshing resulting in improved NVH characteristics. A minimum pressure angle γ also
30 facilitates a greater separation or distance between tangential contact points A and B to further increase or maximize engagement "staging". In the preferred embodiment,

the engaging flank pressure angle γ is in the range of about -3.0° to about $+8^\circ$ to optimize the staged impact between the roller and the sprocket.

In the embodiment being described, roller seating
5 angle β is greater than ISO $\alpha_{\max}/2$ at a maximum material
condition and β can be adjusted until a desired engaging
flank pressure angle γ is achieved. For instance, the
roller seating angle β can provide a pressure angle γ that
is less than zero, or a negative value. It is believed
10 that a small negative pressure angle for the theoretical
chain/sprocket interface beneficially provides a pressure
angle γ closer to zero (0) for a "nominal" system or for a
system with wear. However, the engaging flank roller
seating angle β may be beneficially adjusted so as to
15 provide any engaging flank pressure angle γ having a value
less than the minimum ISO-606 pressure angle.

It should be noted that chordal pitch reduction
may be required when the pressure angle γ has a negative
value. Otherwise, a roller would interfere with the
20 engaging flank (with a maximum material sprocket and a
theoretical pitch [shortest] chain) as it exits the
sprocket wrap back into the span. Also, the reduced
chordal pitch assists the staged mesh as previously
mentioned.

In addition, the disengaging flank roller seating
25 angle β' (Fig. 9) may be adjusted to have a maximum value
which is equal to $\alpha_{\min}/2$ or even less. This reduced seating
angle β' promotes faster separation when the roller leaves
the sprocket and enters the span. This reduced angle β'
30 also allows for the roller in a worn chain to ride up the
coast flank surface to a less severe angle as the roller
moves around the sprocket in the wrap.

Referring now to Figure 10, the sprocket 212 also includes a third tooth 362 having an engaging side or flank 364, and a fourth tooth 366 having a disengaging side or flank 368. The engaging flank 364 and disengaging flank 368 cooperate to define one of the tooth spaces 258 for receiving a roller associated with the chain 216, such as roller 369. Thus, the sprocket tooth 362 is necessarily classified as one of the numbered sprocket teeth 252 (Fig. 8), and the sprocket tooth 366 can be classified as either one of the sprocket teeth 250 or 252.

The engaging roller 369 has a roller diameter D_1 , and is shown fully seated in two-point contact within the tooth space 258. The engaging roller 369 initially contacts the engaging flank 364 at point A' before fully seating in the tooth space at points B' and C. As described above with respect to the asymmetrical tooth space 254, contact points B' and C are actually lines that extend axially along each sprocket tooth surface (i.e., in a direction orthogonal to the plane of the drawings).

The engaging flank 364 has a radius R_f which is tangent to a first non-functional flat surface (not shown) at contact point B'. The flat surface, which functions only to facilitate two-point roller contact, extends radially inward from point B'. A first portion of the root surface 260 defined by radius R_i is tangent to a radially inner end of the first non-functional flank surface at one end thereof, and tangent to a radially outer end of a second non-functional flat surface (not shown) that extends radially outward from Point C, at the other end thereof. More particularly, a maximum value for the root radius R_i must be equal to, or less than, a minimum roller radius $0.5D_1$ in order to insure two-point/line contact at Points B' and C. As a result of $R_i \leq 0.5D_1$, a small clearance

(corresponding to the clearance 273 shown in Figure 9a) is defined between the root surface 260 and the roller 369 when the roller is seated at Points B' and C.

The location of the first non-functional flat surface is determined by the angle β , with the flat orientation being normal or perpendicular to a line that passes through Point B' and the center of roller 369 when the roller is contacting the sprocket at Points B' and C. It should be appreciated that the pressure angle γ , and the amount of pitch mismatch between the chain and the sprocket, can be varied to achieve a desired initial roller contact Point A' at the onset of roller-sprocket meshing. Under theoretical conditions initial roller-sprocket contact occurs at Point B'. However, for all other pitch mismatch conditions, the initial contact occurs at Point A', which is shown to be offset from Point B'.

Thus, for all but the theoretical condition, the initial tangential contact occurs at Point A' at the onset of mesh. The roller 369 is believed to stay in hard contact as the sprocket rotation moves the roller from its initial tangential impact at Point A' into full mesh position at Point B' with its resulting radial contact at Point C. The radial impact force does not occur until the sprocket has rotated sufficiently to bring roller 369 into radial contact at Point C.

Thus, the radial impact force F_R occurs at the instant of full mesh. The taut strand load transfer to the meshing roller is considered to be complete at full mesh. At the instant of the radial collision by roller 369 at Point C, with its resultant radial impact force, the tangential impact force has already occurred and is no longer a factor. The time delay ("staged" engagement) between the tangential and radial roller-sprocket

collisions effectively spreads the impact energy occurring during the meshing process over a greater time interval, thereby reducing its contribution to the generated noise level at mesh frequency. Additionally, the asymmetrical sprocket tooth profile beneficially permits a more gradual taut strand load transfer from a fully engaged roller to a meshing roller as the meshing roller moves from its Point A' initial mesh to its full two-point mesh position at Points B' and C.

10 The root surface 260 incorporates root relief. That is, a second flat surface 372 extends radially inward from Point C. A second portion of the root surface 260, defined by the radius R_i' , is tangent to a radially inner end of the flat surface 372 and is tangent to a radially inner end of a third flat surface 374. The disengaging flank, defined by the radius R_f' , is tangent to a radially outer end of the third flat surface 374.

15 It should be appreciated that the second non-functional flat surface (extending radially outward of Point C) is contiguous with the flat surface 372. That is, a first portion of the flat surface 372 extends radially outward from Point C and cooperates with the first non-functional flat surface extending radially inward from Point B to facilitate the roller seating in two-point contact at Points B' and C. A second portion of the flat surface 372 extends radially inward of Point C and cooperates with the third flat surface to provide root relief.

20 As indicated above, a clearance 376 exists between the roller 369 and the relieved root surface 260 when the roller 369 is seated in full mesh at Points B' and C. For the root relieved tooth space 258, the roller 369 contacts point B' at full mesh when its center is on the

theoretical pitch diameter PD. The second root radius R_i' is necessarily equal to, or less than, one-half the diameter of roller 369. Figure 10 also illustrates the roller clearance 378 to the disengaging flank 368 for the full mesh position of the roller 369 when seated at points B' and C. The tooth space 258 provides root relief in the same manner as the tooth space 254. That is, the roller 369 is prohibited from contacting the root surface 260 when the roller bridges across the root surface and seats at points S and S' (see clearance 280, Fig. 9c). Thus, the roller 369 can contact only the lower engaging and disengaging flanks. It should be appreciated that as the roller continues to travel around the sprocket wrap, the roller moves outward from Point S' along the disengaging flank 368.

Pitch mismatch is inherent in a chain/sprocket interface except at one condition - the theoretical condition which is defined as a chain at its shortest pitch (shortest being theoretical pitch) and a maximum material sprocket. This theoretical condition therefore defines one limit (zero, or no pitch mismatch) of the tolerance range of the pitch mismatch relationship of chain and sprocket. The other limit is defined when a longest "as built" chain is used with a sprocket at minimum material conditions - or in other words, a sprocket having a minimum profile. This limit produces the greatest amount of pitch mismatch. The pitch mismatch range is therefore determined by the part feature tolerances.

Additional pitch mismatch may be introduced to facilitate a greater time delay between the initial tangential (meshing) contact at point A (for the asymmetrical tooth spaces 254) and the initial tangential contact at point A' (for the asymmetrical tooth spaces

258). That is, varying the time at which the initial roller-to-sprocket contact occurs for each tooth space 254, 258 results in reduced mesh frequency noise because the point and rhythm of the initial roller-to-sprocket contacts are altered. The time delay, or modulation, between the roller-to-sprocket contact at points A and A' may be increased by increasing the mismatch between the chain pitch and sprocket pitch. It should be appreciated that the initial contact occurs earlier for the tooth space 254 than for the tooth space 258 primarily because of the β angle difference (refer to Figure 11) and, to a lesser degree, the flank flat 270 which causes initial contact to occur higher up on the engaging flank of the sprocket teeth 250.

The sprocket chordal pitch is necessarily shorter than the chain pitch to facilitate the staged roller-tooth contact. In addition, chordal pitch reduction also provides roller-to-flank clearance as the roller exits the sprocket wrap back into the strand. Added chordal pitch reduction, when used, is preferably in the range of 0.005-0.050 mm.

The staged roller contact for each tooth space 254, 258 may be further assisted by providing sprocket tooth pressure angles γ that are substantially less than the ISO standard. Pressure angles γ equal to or very close to zero (0), or even negative pressure angles, are contemplated. For instance, Figure 11 illustrates one embodiment of the random engagement drive sprocket 212 wherein the pressure angles γ for the tooth spaces 254, 258 are different. That is, both pressure angles γ are either a positive value or zero, but the pressure angle γ_{254} for tooth space 254 is smaller than the pressure angle γ_{258} for tooth space 258 (and the roller seating angle β_{254} is greater than

the roller seating angle β_{258}). Thus, γ_{\min} may be equal to 0° for the tooth space **254**, γ_{\min} may be equal to $+8^\circ$ for the tooth space **258**, and γ_{\max} for both tooth spaces will always be less than the ISO minimum pressure angle (the feature tolerance band or range for γ_{\min} and γ_{\max} is the same for both tooth spaces **254**, **258**).

As a result, initial roller-to-sprocket contact occurs at point A followed by subsequent radial contact at points B and C for the tooth space **254**. And, initial roller-to-sprocket contact occurs at point A' followed by subsequent radial contact at points B' and C for the tooth space **258**. The sprocket **212** can incorporate additional chordal pitch reduction, and can incorporate tooth space clearance (TSC), as described in U.S. Patent No. 5,921,878, the disclosure of which is hereby incorporated by reference for all that it teaches. Tooth space clearance (TSC) enables rollers of a worn chain to be maintained in hard contact with one or more inclined root surfaces of the sprocket teeth. That is, one or more of the flat surfaces **272**, **274** (Fig. 9) and **372**, **374** (Fig. 10) can be used to compensate for chain pitch elongation or chain wear by accommodating a specified degree of chain pitch elongation ΔP . In addition, the inclined root surfaces facilitate reducing the radial reaction force thereby reducing the roller radial impact noise contribution to the overall noise level. It should be appreciated that a shallow β' angle, in conjunction with tooth space clearance, helps maintain "hard" roller-sprocket contact for the rollers in the wrap.

Alternatively, the pressure angle γ_{\min} for the tooth spaces **254** may always be a negative value, while the pressure angle γ_{\min} for the tooth spaces **258** may always be a positive value or zero. For instance, γ_{\min} may be equal to -

3° for the tooth spaces 254, γ_{\min} may be equal to +8° for the tooth spaces 258, and γ_{\max} for both profiles will always be less than the ISO minimum pressure angle. With this embodiment, additional chordal pitch reduction will always be included, however, tooth space clearance may or may not be included. In yet another embodiment, the tooth spaces 254, 258 can have the same, or at least substantially the same, pressure angles γ (thus, the tooth spaces have the same or at least substantially the same roller seating angles β_{254} and β_{258}).

Figure 12 illustrates the path (phantom) that each of the roller link plates, such as roller link plates 248, follow as they come into meshing contact with the sprocket 212. The roller link plates 248 pivot about the center of fully meshed roller 228 and compress the resilient cushion or damping rings 244 that are secured to the hub 213 of the sprocket 212 (see also Figure 8a) on opposite front and rear faces of the teeth 250 and/or 252 as the roller 230 moves into meshing engagement in the corresponding sprocket tooth space.

With continuing reference to Figure 12 and also now to Figure 12a, the annular elastomeric (e.g., rubber) damping/cushion rings 244 each include an uneven or undulated outer surface 400 formed from alternating compression pads 402 and transverse or axially extending grooves 404. The compression pads 402 each have an outer surface 406 that is arcuate, planar or that otherwise extends generally along an outer diameter OD_E of the cushion rings 244 between a leading or upstream end 406a to a trailing or downstream end 406b. Both the leading end 406a and trailing end 406b of each compression pad 402 are preferably located at a common radial distance from the center or central longitudinal axis CL of the sprocket 212

(see also Figures 8,8a) and, most preferably, both the leading and trailing ends **406a,406b** are located on the outer diameter OD_E of the cushion ring **244**. Between the leading and trailing ends **406a,406b**, the outer surface **406** can have any desired shape or configuration, but it is symmetrical about a mid-point **406c** that bisects the outer surface **406** of the compression pad **402**. Thus, preferably, the cushion ring **244** includes a symmetrical outer surface or outer diameter OD_E as defined by the symmetrical compression pads **406**. Also, the outer surface **406**, between the leading and trailing ends **406a,406b** thereof, is preferably smooth and either planar or extends smoothly and arcuately along with the outer diameter OD_E of the cushion ring **244**.

Thus, the outer surface **406** of each compression pad **402** is defined so that the pad **402** is compressed evenly and uniformly from the leading end **406a** to the trailing end **406b** by the links **248** of the chain as the roller **230** moves into engagement with the sprocket **212**. In other words, with continuing reference to the example illustrated in Figure 12, the compression gradient of each compression pad **402** is evenly distributed between the seated roller **228** and the next-meshing roller **230**.

The grooves **404** located between successive compression pads **402** of each cushion ring **244** extend transversely or axially (i.e., parallel to the central axis **CL** of the sprocket **212**) provide for minimum or no compression of the cushion rings **244** for that portion of the link plates of the roller chain located adjacent the seated and pivoting roller **228**, where compression would provide little or no benefit. Further, the grooves **404** provide voids or spaces into which the elastomeric material forming the trailing ends **406b** of the compression pads **402**

can move during meshing of each roller and subsequent rotation of that roller through the sprocket wrap 232 (Fig. 7).

With reference now to Figure 12b, each groove 404 is defined by at least one radius R_2 extending from an arc center 408 of the groove 404 (in the embodiment being described, the grooves 404 are defined by at least two radii). Likewise, a portion of the root surfaces 256, 260 of the tooth spaces 254, 258, respectively, is defined by a radius R_1' that extends from an arc center 410 of the root surface portion defined by the radius R_1' .

Thus, in the illustrated example, a radial line 412 can be drawn between the arc center 410, the arc center 408 and the center CL of the sprocket 212. It can be seen that the cushion rings 244, and more particularly, the compression pads 402 and grooves 404, are oriented relative to the sprocket 212 such that the arc centers 408 of the grooves 404 are aligned along the radial line 412. More generally, in accordance with the present invention, each groove 404 of each cushion ring 244 is located radially inward from and circumferentially aligned with one of the tooth spaces 254, 258 of the sprocket 212. Most preferably, each groove 404 is bisected by the radial line 412 that extends from the center CL of the sprocket 212 through the arc center 410. Also, while the grooves 404 illustrated here are defined by a radius such as the radius R_2 , it is also contemplated that the grooves be otherwise defined or conformed, i.e., the grooves can be defined by one or more planar surfaces and/or other non-planar surfaces.

Referring now to Figure 12c, the sprocket 212 has been rotated in the clockwise direction 11 (as compared to Figure 12) until the roller 230 is fully seated in two-point driving contact with the sprocket 212. It can be

seen that the outer surface **406** of the compression pad **402** is compressed uniformly by an amount **249** between its leading and trailing ends **406a,406b** when the two consecutive rollers **228,230** are engaged with the sprocket **212** as shown in Figure 12c.

Referring now to Figure 12d, roller **282** is shown to be in contact with the engaging tooth flank at the point indicated by the short line **286a** normal to the roller and tooth flank. The roller **284** is shown to be in contact with the disengaging tooth flank at the location **286b** in the tooth space that it occupies. The forward progression of roller **282**, in its angular position shown in Figure 12d until it contacts the disengaging flank of the adjacent tooth, will take place somewhere between its present position and the angular position currently occupied by roller **284**.

Figure 12e shows sprocket **212** rotated in the direction of arrow **11** through some angle less than tooth angle A until the instant at which roller **282** contacts both flanks as indicated by the lines **S,S'**. As mentioned previously, to achieve this condition, the roller **282** must move radially inward a distance **288**, further compressing the pads of the rubber cushion rings **244**, in order for contact to occur at the points **S,S'** on both flanks. The center of roller **282** may, in fact, stay on the pitch diameter **PD** as it progresses from the engaging flank contact to the disengaging flank contact. In either case, the cushion rings **244** inhibit the rollers in the sprocket wrap **232** from vibrating as would lead to intermittent contact of the rollers with the sprocket teeth, resulting in generation of undesired broadband noise.

It should be noted that the different sets of sprocket teeth can be arranged in many regular patterns, as

opposed to an arbitrary pattern, that would work equally as well. In all cases, the arrangement of two sets of different sprocket teeth on a sprocket provides a means for breaking up the mesh frequency impact noise normally associated with and induced by a full complement of substantially identically shaped sprocket teeth. Mesh frequency noise reduction and broadband noise reduction are achieved by altering the point and rhythm of initial roller-to-sprocket contacts from one tooth profile to the next, and by buffering or softening the engaging impact of the roller as they leave the span and collide with the sprocket during the meshing process.

The above-described random engagement roller chain drive sprocket **212** has two groups of sprocket teeth, each having a different tooth profile that incorporates root relief. However, it is contemplated that only one of the two sets of sprocket teeth be used and/or incorporate root relief. It is also contemplated that only certain ones of the first and/or second plurality of sprocket teeth incorporate root relief.

The crankshaft sprocket, generally the smallest sprocket in the chain drive, is usually the major noise contributor. The typically larger driven camshaft sprocket, however, will also contribute to the generated noise levels, but generally to a lesser extent than the crankshaft sprocket. However, the driven sprocket, particularly if it is nearly the same size or smaller than the driving sprocket, may be the prime noise generator, as in the case with balance shaft sprockets and pump sprockets. Thus, the features of the present invention may also be used advantageously with camshaft or driven sprockets as well.

It should be appreciated that the disclosed asymmetrical tooth profile features can be altered slightly

without substantially deviating from the chain and sprocket meshing kinematics that produce the noise reduction advantages of the present invention. For example, the engaging asymmetrical flank profiles can be approximated by an involute form, and the disengaging asymmetrical flank profiles can be approximated by a different involute form. Slight changes to the profile may be done for manufacturing and/or quality control reasons - or simply to improve part dimensioning.

It is also contemplated that one or more of the cushion rings 244 of the present invention can be mounted to a known ISO-606 compliant sprocket or any other sprocket with symmetrically formed teeth and tooth spaces, such as the sprocket 12 (Fig. 2), in order to achieve NVH gains over an ISO-606 compliant sprocket incorporating a known cushion ring, such as the cushion ring 144 (Figs. 6-6b). Referring now to Figure 13a, an ISO-606 compliant sprocket 512 includes a plurality of symmetrical sprocket teeth 514. Successive adjacent sprocket teeth cooperate to define a symmetrical tooth spaces 516 having root surfaces 518. At least one elastomeric cushion ring 244 is mounted to the sprocket 512. Preferably a cushion ring 244 is mounted adjacent each axial face of the sprocket 512 so that the teeth 514 are located axially between the two cushion rings 244 as described above in relation to the sprocket 212.

In the illustrated embodiment of Figure 13a, each groove 404 is defined by at least one radius R_2 extending from an arc center 520 of the groove 404 (in the embodiment being described, the grooves 404 are defined by at least two radii). Likewise, the root surface 518 of each symmetric tooth space 516 is defined by a radius R_1 that extends from an arc center 522 of the root surface defined by the radius R_1 . A radial line 524 can be drawn between

the arc center 522 of the root surface portion defined by the radius R_1 and the center (not shown) of the sprocket 512. The cushion ring 244, and more particularly, the compression pads 402 and grooves 404, are preferably oriented relative to the sprocket such that the arc centers 520 of the groove portions defined by the radii R_2 are positioned at least proximate the radial lines 524. In this case, a radial line 524 can be drawn at least through a portion of each groove 404. Preferably, the arc centers 10 520 of the groove portions defined by the radii R_2 are positioned on the radial lines 524. In this case, the radial lines 524 bisect the grooves 404. More generally, as noted above, it is preferred that the grooves 404 of the cushion rings 244 be located radially inwardly from and be at least partially circumferentially overlapped by the root surfaces 518, respectively. 15

Figure 13b partially illustrates a sprocket 512' including cushion rings 244 in accordance with the present invention. Except as otherwise shown and described, the sprocket 512' and the cushion rings 244 secured thereto are identical to the sprocket 512 just described and illustrated in Figure 13a. The sprocket 512', however, is slightly modified in that the root surface 518 (shown in phantom) has been relieved so that a relieved root surface 25 518' defines at least a portion of the root between successive teeth 514. In particular, the relieved root surface 518' is defined so that a roller (see roller R1 in Figure 14) of the associated roller chain, when fully seated in the tooth space 516', will not contact the relieved root surface 518'. The relieved root surface 518' can be defined by one or more radii and/or by one or more flats, and the shape of the relieved root surface 518', 30

itself, is unimportant in that it never contacts a roller of the roller chain.

The precise location and length of the relieved root surface 518' can be varied without departing from the overall scope and intent of the present invention. It is preferred, as illustrated, that the relieved root surface 518' be symmetrically defined relative to the tooth space 516', i.e., symmetrically defined about the radial line 524 that bisects the tooth space 516', although this is not required. At a minimum, however, it is important that an associated roller, when fully seated in the tooth space 516' be spaced from the sprocket at the center of the tooth space 516'. i.e., at the radial line 524.

With respect to the symmetrical sprockets 512,512', or any other symmetrical sprockets, symmetrical cushion rings 244 formed in accordance with the present invention provide a significant advantage over known "saw-tooth" cushion rings or other cushion rings having a non-symmetrical outer surface in that the cushion rings 244 can be mounted or insert-molded to either side of the sprocket teeth 514 without being installed backwards. Stated another way, the cushion rings 244 function properly regardless of the direction in which they rotate if they are secured to a symmetric sprocket such as the sprockets 512,512'. Thus, in a mounting operation, assembly time and errors are reduced, while in an insert molding operation, where the sprocket 512,512' is placed in an injection mold and the cushion rings molded directly thereto, there is no requirement that the sprocket be placed "right-side-up."

Figure 14 illustrates the sprocket 512' of Figure 13b and shows a preferred cushion ring conformation and location where each compression pad 402 comprises a planar outer surface 406 that is parallel to a chord or

line segment **CR12** that extends between the centers of two adjacent rollers **R1,R2** when the rollers are both fully seated in their respective tooth spaces **516'** and located adjacent opposite ends of the compression pad **402**. In this manner, the compression pad **402** is compressed a uniform amount **X49** by the link extending between the rollers **R1,R2**.

This relationship, wherein the pad is conformed and arranged so that the surface **406** is planar and lies parallel to the line segment **CR12** and so that the surface **406** is compressed uniformly along its length by a link extending between the adjacent fully seated rollers **R1,R2** is referred to as Tau (T) = 0°

The invention has been described with reference to the preferred embodiment. Obviously, modifications will occur to others upon a reading and understanding of this specification and this invention is intended to include same insofar as they come within the scope of the appended claims or the equivalents thereof.

For instance, it should be appreciated that the tooth space embodiments of the present invention can be classified as being asymmetrical when: i) the engaging side roller seating angle β is greater than the disengaging side roller seating angle β' ; and, ii) the engaging side roller seating angle β is equal to disengaging side roller seating angle β' and the engaging side profile is different than the adjacent disengaging side profile, such as when the engaging side includes a flank flat **270** etc. Further, the engaging asymmetrical flank profile could be approximated by an involute form, and the disengaging asymmetrical flank profile could be approximated by a different involute form.

Although the cushion rings **244** have been described herein as being secured to an axially projecting hub of the various sprockets **212,512,512'**, those of

ordinary skill in the art will recognize that the one or more cushion rings can be secured directly to the opposite front and/or rear faces of a sprocket instead of to a hub.

This will occur, e.g., in connection with a sprocket that
5 does not include an axially extending hub. The cushion ring(s) must simply be located as described herein adjacent the sprocket teeth and tooth spaces to engage the link plates of the associated roller chain as described.

10

Having thus described the preferred embodiments, the invention is now claimed to be:

1. A sprocket comprising:
 - 5 a hub;
 - a plurality of teeth projecting radially outwardly from said hub;
 - at least one cushion ring located adjacent said teeth, said cushion ring defining a plurality of compression pads
 - 10 separated from each other by grooves, each of said compression pads defined symmetrically about a circumferential mid-point.
2. The sprocket as set forth in claim 1, wherein
- 15 each of said plurality of compression pads comprises an outer surface having a leading end and a trailing end located a common radial distance from a center of said hub about which said sprocket rotates.
3. The sprocket as set forth in claim 1, wherein
- 20 said at least one cushion ring comprises first and second cushion rings located respectively adjacent opposite first and second axial faces of said teeth.
4. The sprocket as set forth in claim 3, wherein
- 25 said first and second cushion rings are mounted on said hub.
5. The sprocket as set forth in claim 1, wherein
- 30 said at least one cushion ring is mounted on said hub.
6. The sprocket as set forth in claim 1, wherein said grooves comprise axially extending grooves that are

radially aligned with tooth spaces separating successive ones of said plurality of teeth.

7. The sprocket as set forth in claim 3, wherein
5 said grooves comprise axially extending grooves that are radially aligned with tooth spaces separating successive ones of said plurality of teeth.

8. The sprocket as set forth in claim 1, wherein
10 said grooves are defined by radii centered at a respective groove arc centers and wherein said plurality of teeth of said sprocket are separated by root surfaces at least partially defined by a radii centered at respective root arc centers, and wherein each of said groove arc centers is
15 aligned with one of said root arc centers.

9. The sprocket as set forth in claim 1, wherein each compression pad comprises an outer surface defined by an arcuate surface.

20

10. The sprocket as set forth in claim 1, wherein each compression pad comprises an outer surface defined by a planar surface.

25 11. The sprocket as set forth in claim 10, wherein each of said compression pads is conformed to comprise an outer surface that lies parallel to a line segment that extends between two associated rollers of an associated chain when the two associated rollers are fully seated in
30 respective adjacent tooth spaces.

12. The sprocket as set forth in claim 1, wherein said plurality of teeth are separated from each other by a symmetrical tooth space.

13. The sprocket as set forth in claim 1, wherein said plurality of teeth are separated from each other by an asymmetrical tooth space.

5

14. The sprocket as set forth in claim 12, wherein said plurality of teeth are separated from each other by a root surface that is conformed with a relieved surface that is spaced from an associated roller when the associated
10 roller is fully seated in said tooth space.

15. The sprocket as set forth in claim 1, wherein said plurality of teeth comprise at least two different tooth profiles.

15

16. The sprocket as set forth in claim 15, wherein said at least two different tooth profiles are randomly located about said hub.

17. The sprocket as set forth in claim 1, wherein said at least one cushion ring comprises an elastomeric compound.

20

18. A sprocket comprising:
25 a hub;
a plurality of teeth projecting radially outwardly from said hub;

at least one cushion ring located adjacent said teeth, said cushion ring defining a symmetrical outer
30 surface that comprises a plurality of axially extending grooves defined therein.

19. A sprocket comprising:
a hub;

a plurality of teeth projecting radially outwardly from said hub;

at least one cushion ring located adjacent said teeth and comprising a plurality of compression pads separated from each other by grooves, said cushion ring being operable identically in first and second opposite rotational directions.

20. A sprocket comprising:

10 a hub;

a plurality of teeth projecting radially outwardly from said hub;

at least one cushion ring located adjacent said teeth, said cushion ring defining a plurality of compression pads separated from each other by grooves, each of said compression pads comprising an outer surface having a leading end and a trailing end located a common radial distance from a center of said hub about which said sprocket rotates.

20

21. The sprocket of claim 20, wherein said outer surface of each of said compression pads comprises a planar surface.

25 22. The sprocket as set forth in claim 21, wherein said planar outer surface of each of said compression pads extends between and include said leading end and said trailing end.

30

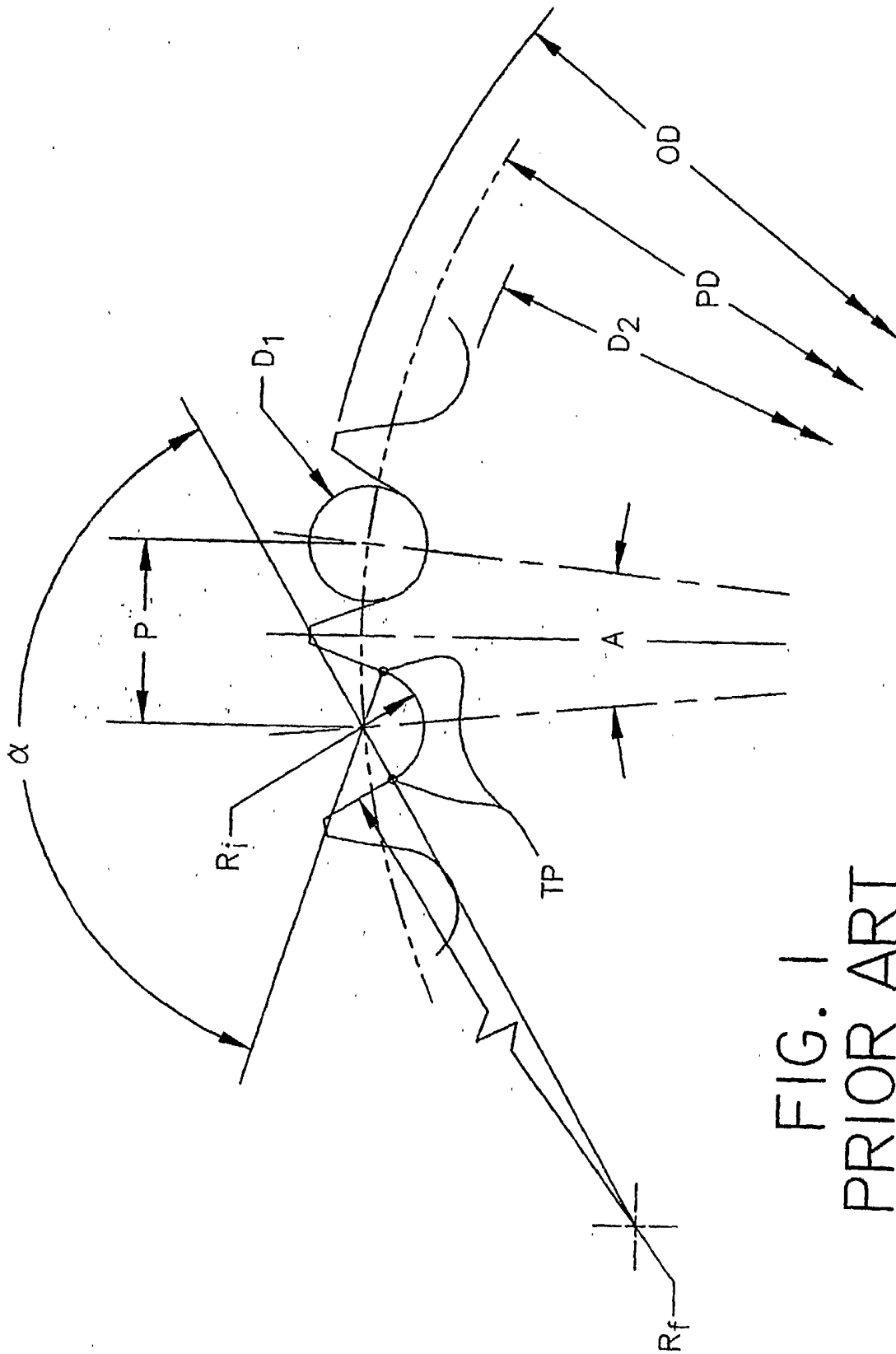

FIG. 1
PRIOR ART

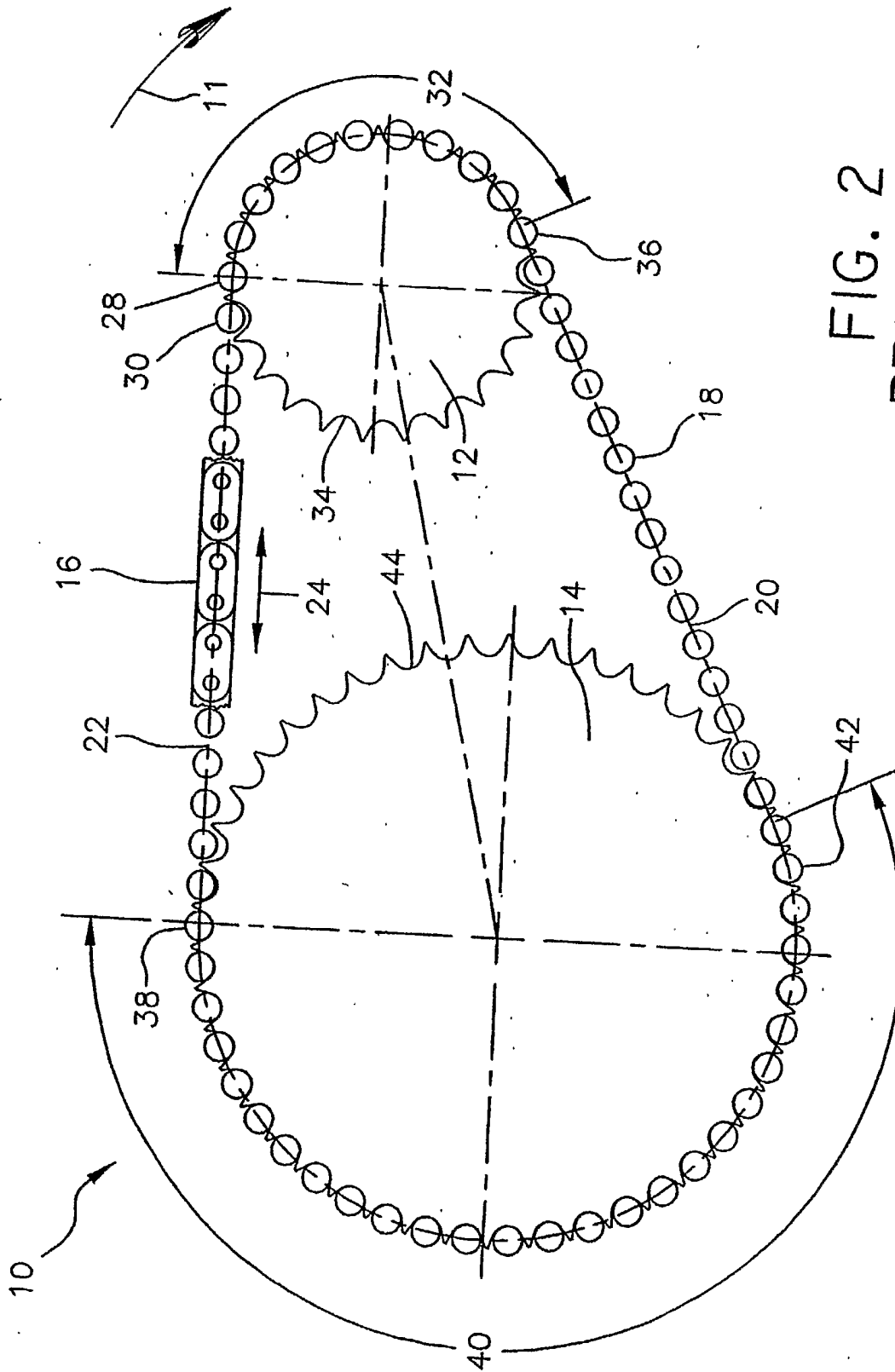

FIG. 2
PRIOR ART

ISO

Z	A	α		γ	
		(MIN)	(MAX)	(MAX)	(MIN)
18	20.000	115.00	135.00	22.500	12.500
19	18.947	115.26	135.26	22.895	12.895
20	18.000	115.50	135.50	23.250	13.250
21	17.143	115.71	135.71	23.571	13.571
22	16.364	115.91	135.91	23.864	13.864
23	15.652	116.09	136.09	24.130	14.130
24	15.000	116.25	136.25	24.375	14.375
25	14.400	116.40	136.40	24.600	14.600
26	13.846	116.54	136.54	24.808	14.808
27	13.333	116.67	136.67	25.000	15.000
28	12.857	116.79	136.79	25.179	15.179
29	12.414	116.90	136.90	25.345	15.345
30	12.000	117.00	137.00	25.500	15.500

FIG. 4
PRIOR ART

ASYMMETRICAL

Z	A	1		2		3	
		β (MAX)	γ (MIN)	β (MAX)	γ (MIN)	β (MAX)	γ (MIN)
18	20.000	73.75	8.75	76.92	4.33	80.00	-3
19	18.947	74.08	9.03	77.29	4.53	80.53	-3
20	18.000	74.38	9.28	77.62	4.71	81.00	-3
21	17.143	74.64	9.50	77.92	4.87	81.43	-3
22	16.364	74.89	9.70	78.19	5.02	81.82	-3
23	15.652	75.11	9.89	78.43	5.15	82.17	-3
24	15.000	75.31	10.06	78.66	5.28	82.50	-3
25	14.400	75.50	10.22	78.87	5.39	82.80	-3
26	13.846	75.67	10.37	79.06	5.50	83.08	-3
27	13.333	75.83	10.50	79.24	5.59	83.33	-3
28	12.857	75.98	10.63	79.41	5.68	83.57	-3
29	12.414	76.12	10.74	79.56	5.77	83.79	-3
30	12.000	76.25	10.85	79.70	5.85	84.00	-3

FIG. 5

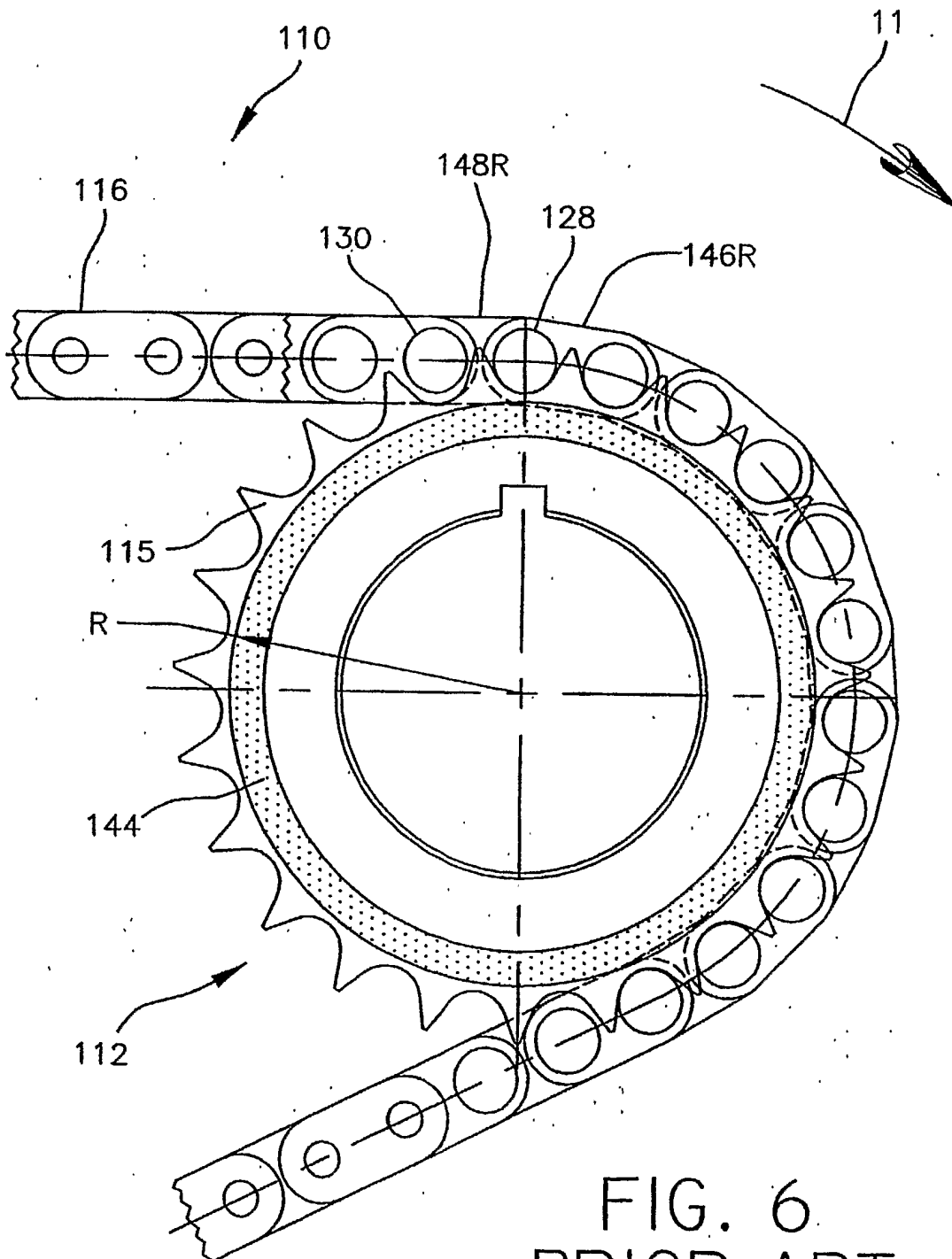

FIG. 6
PRIOR ART

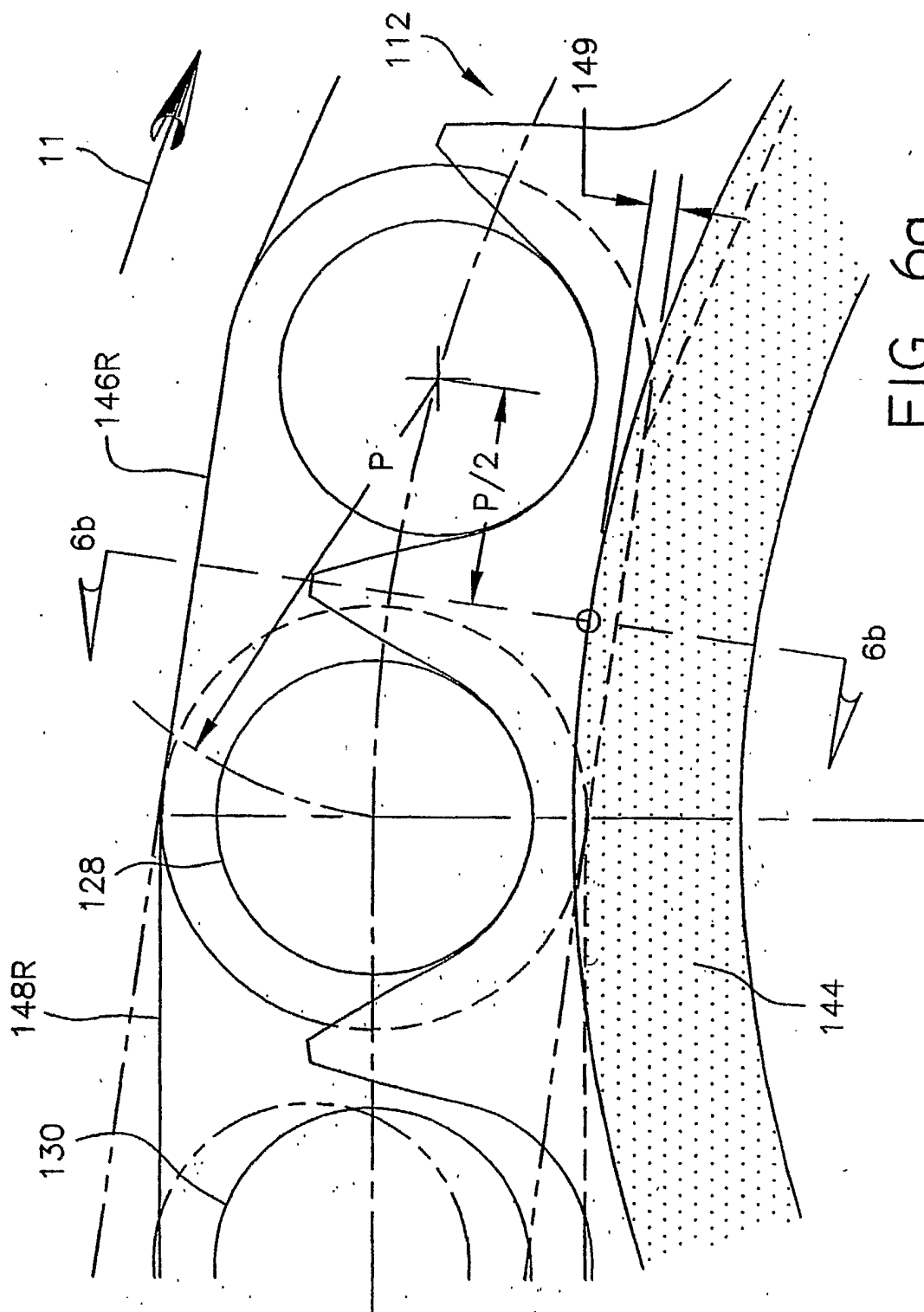

FIG. 6a
PRIOR ART

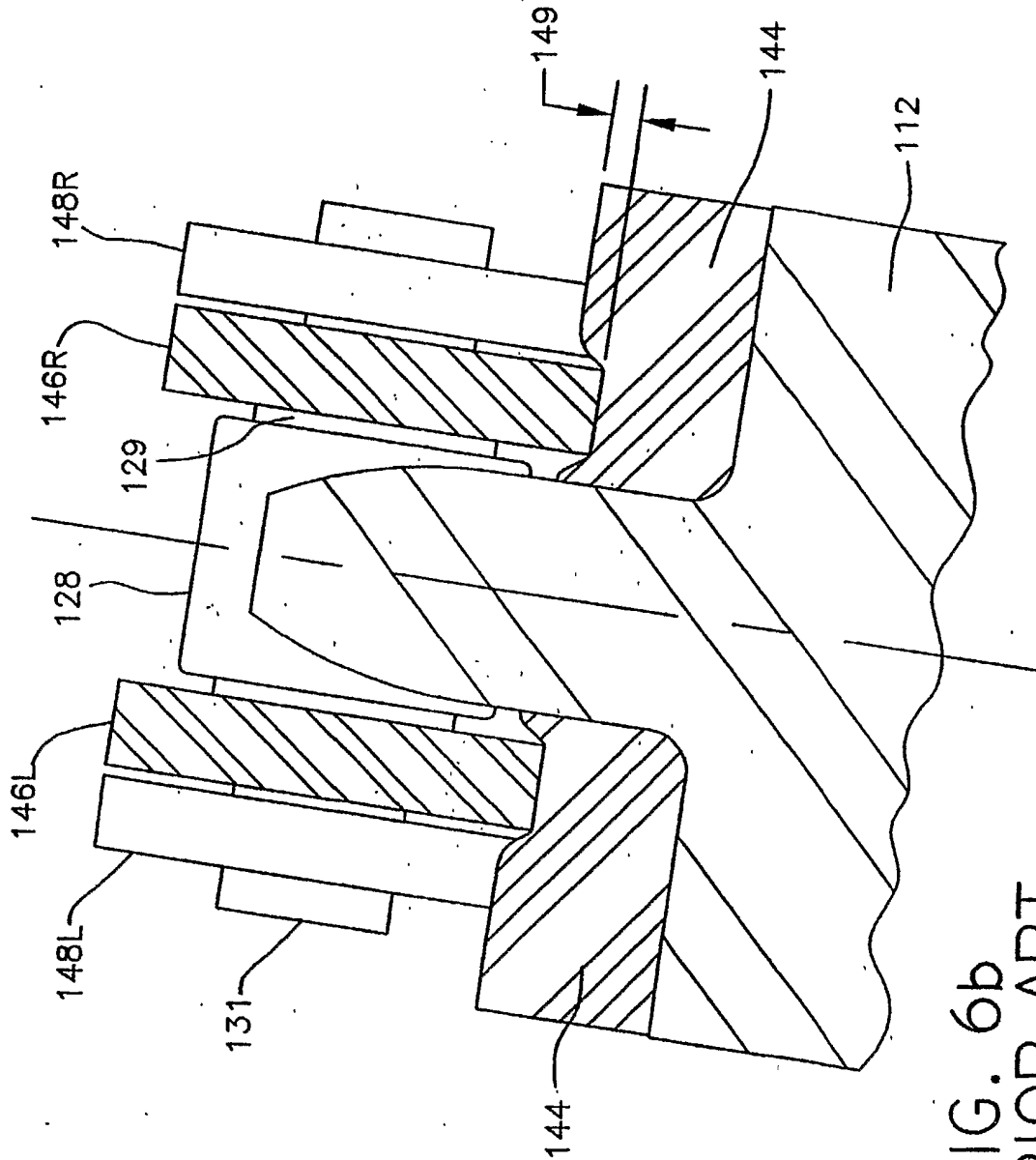

FIG. 6b
PRIOR ART

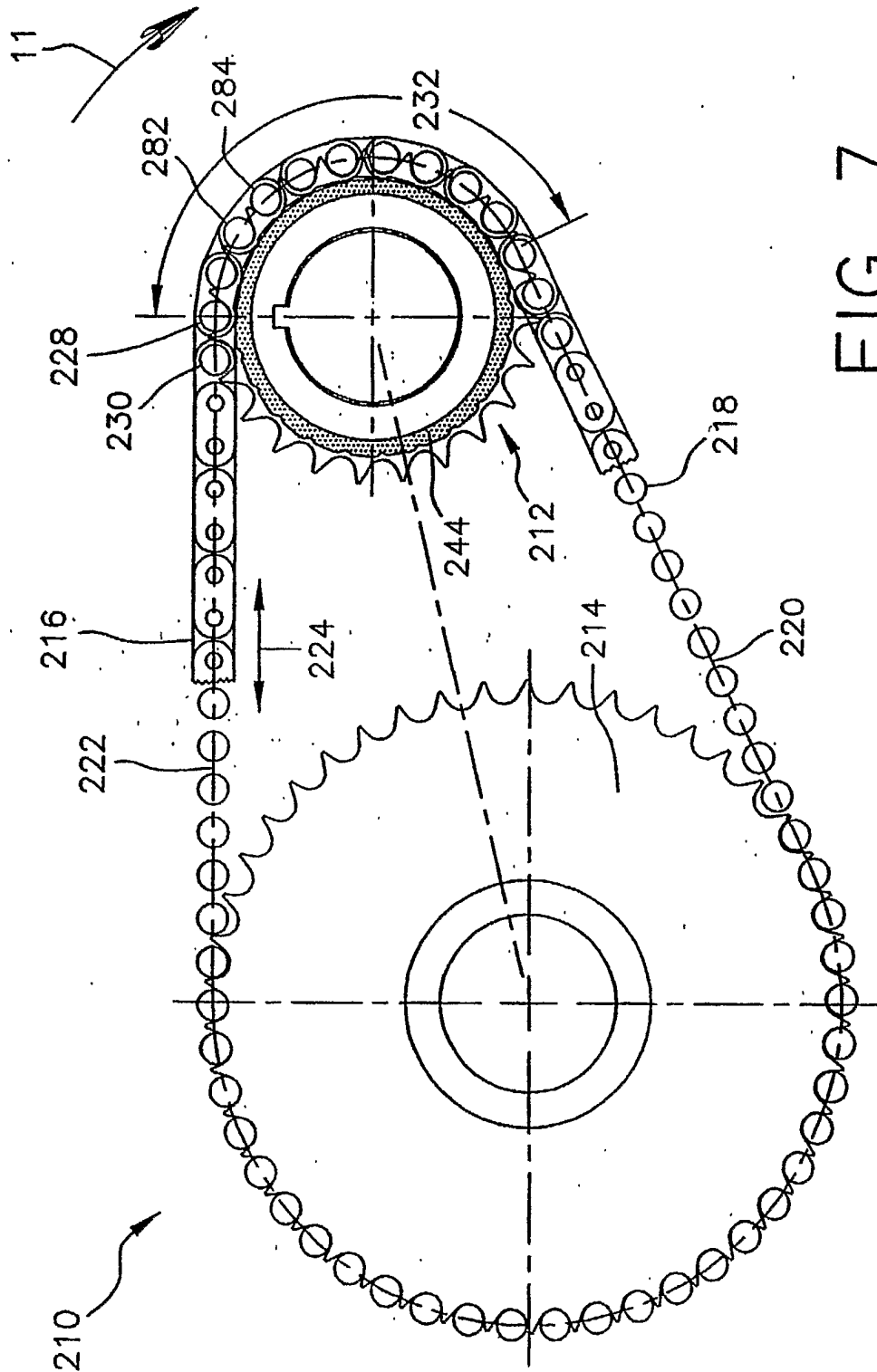

FIG. 7

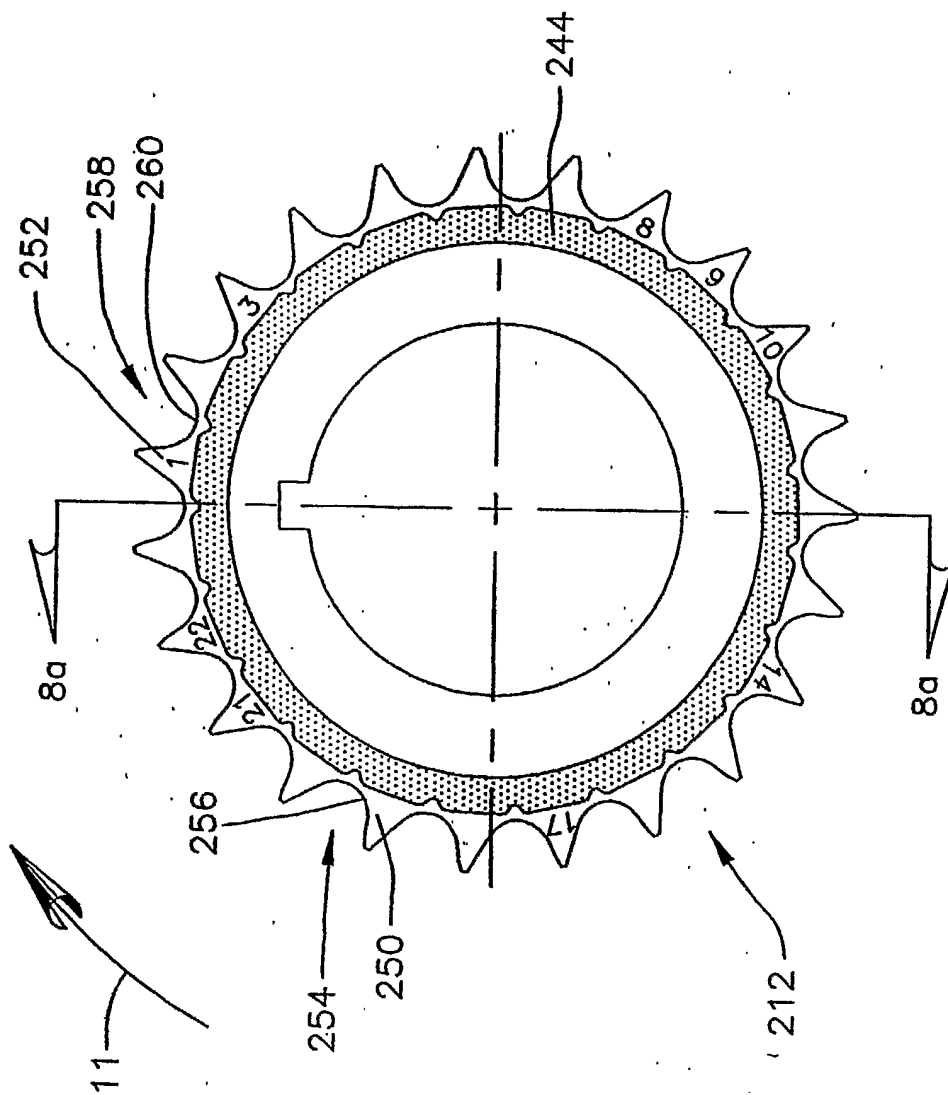

FIG. 8

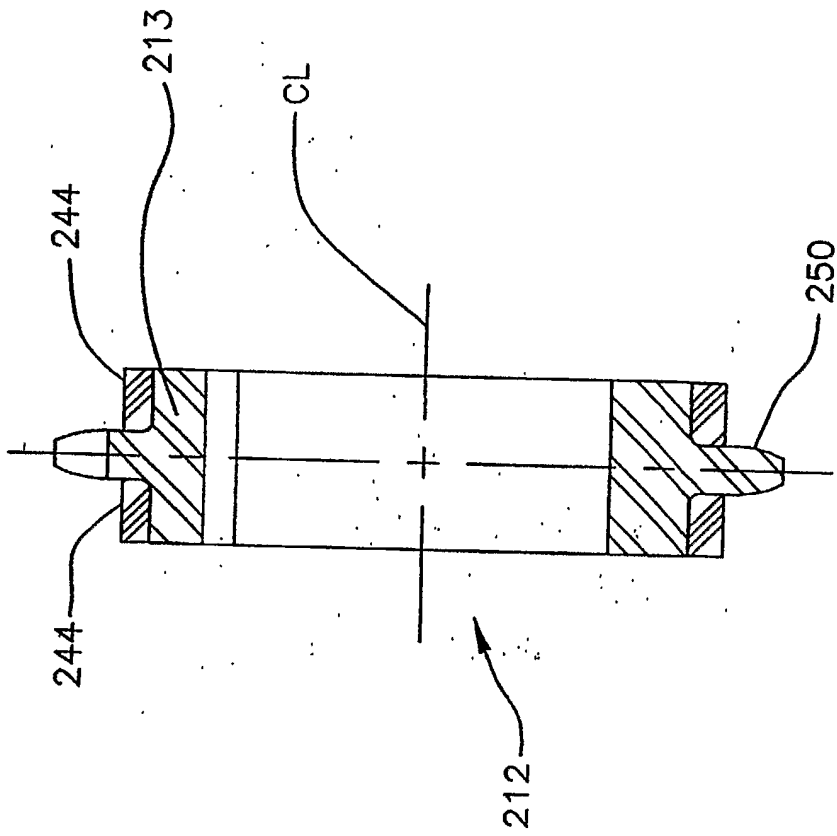

FIG. 8a

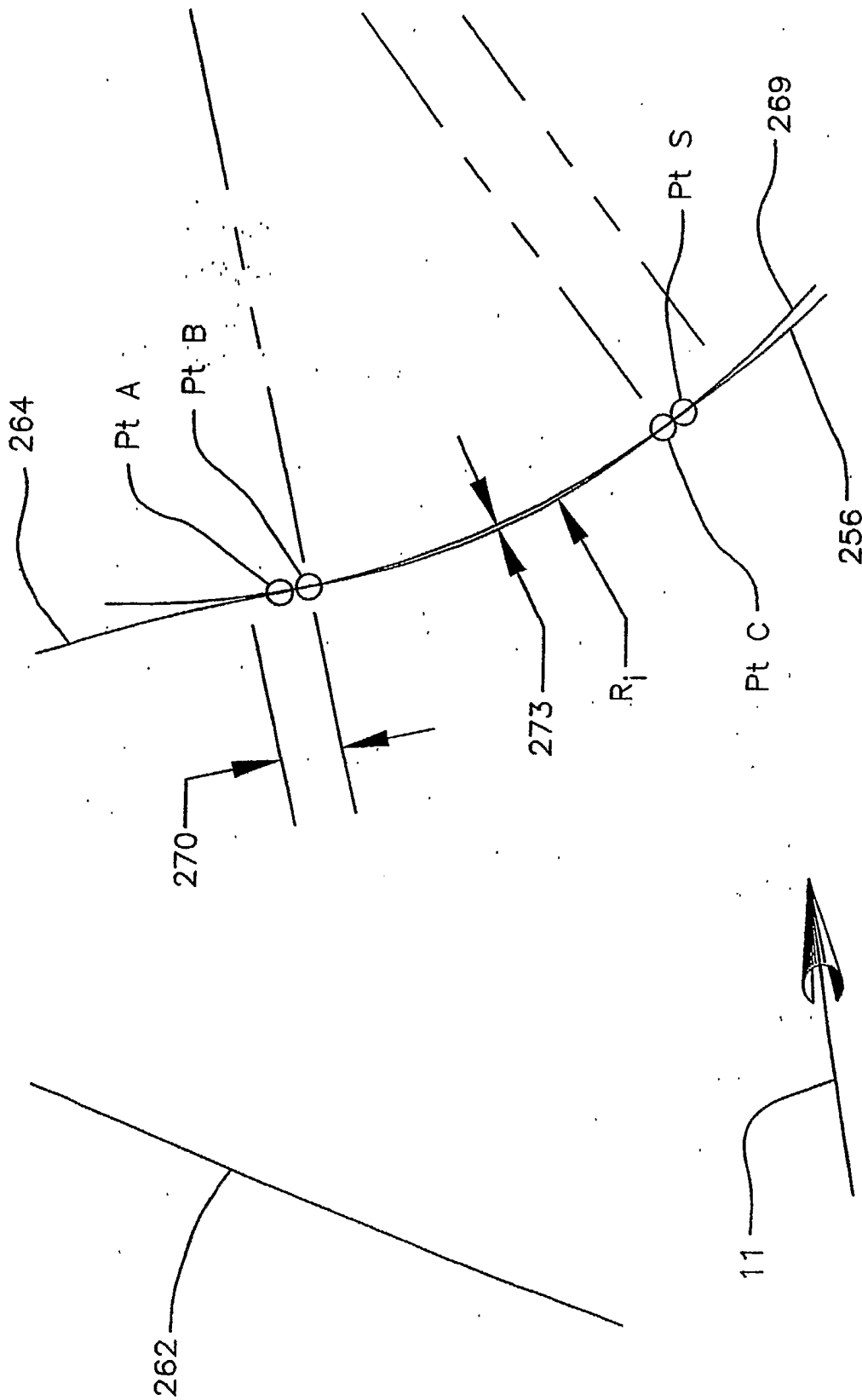

FIG. 9a

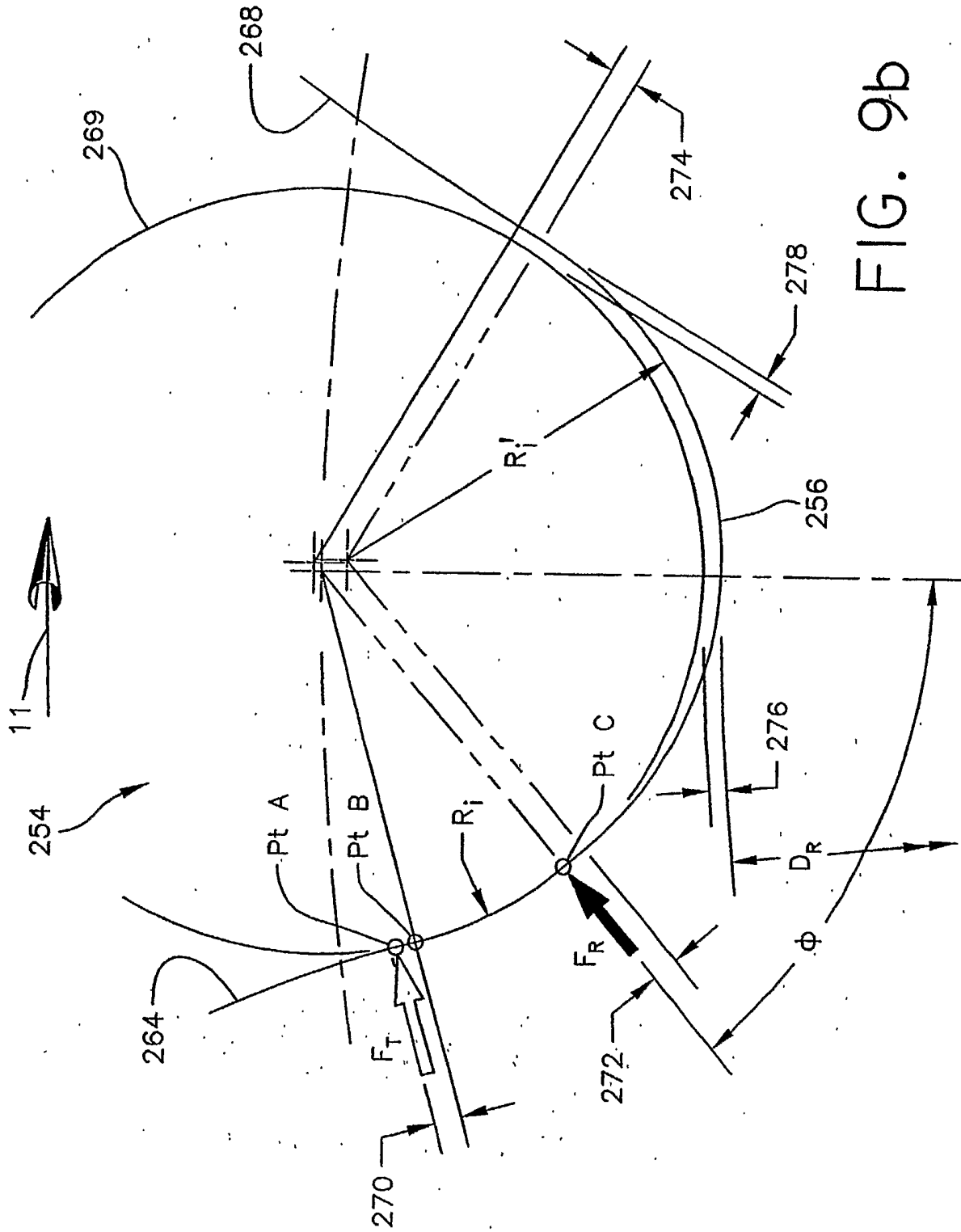

FIG. 9b

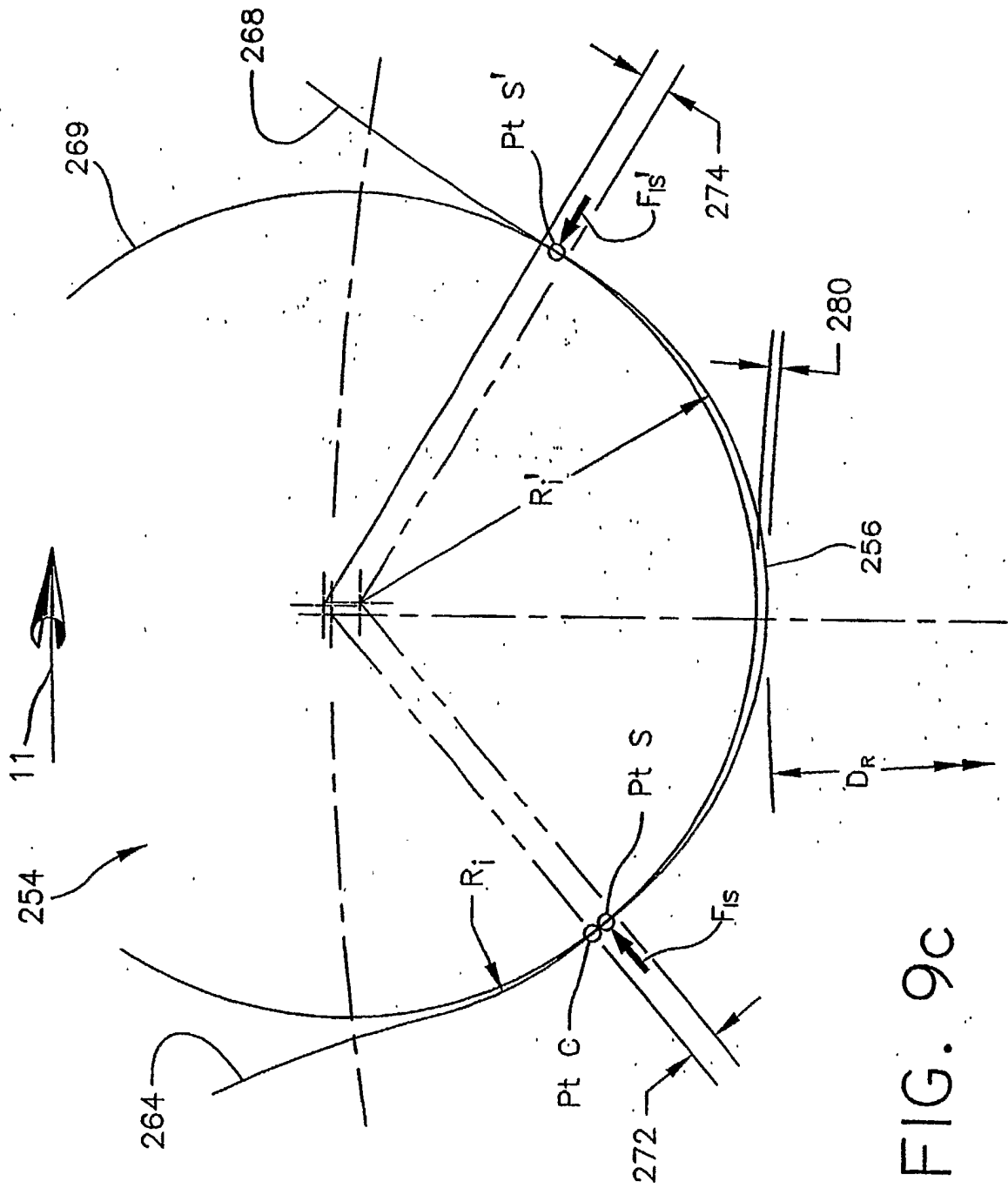

FIG. 9c

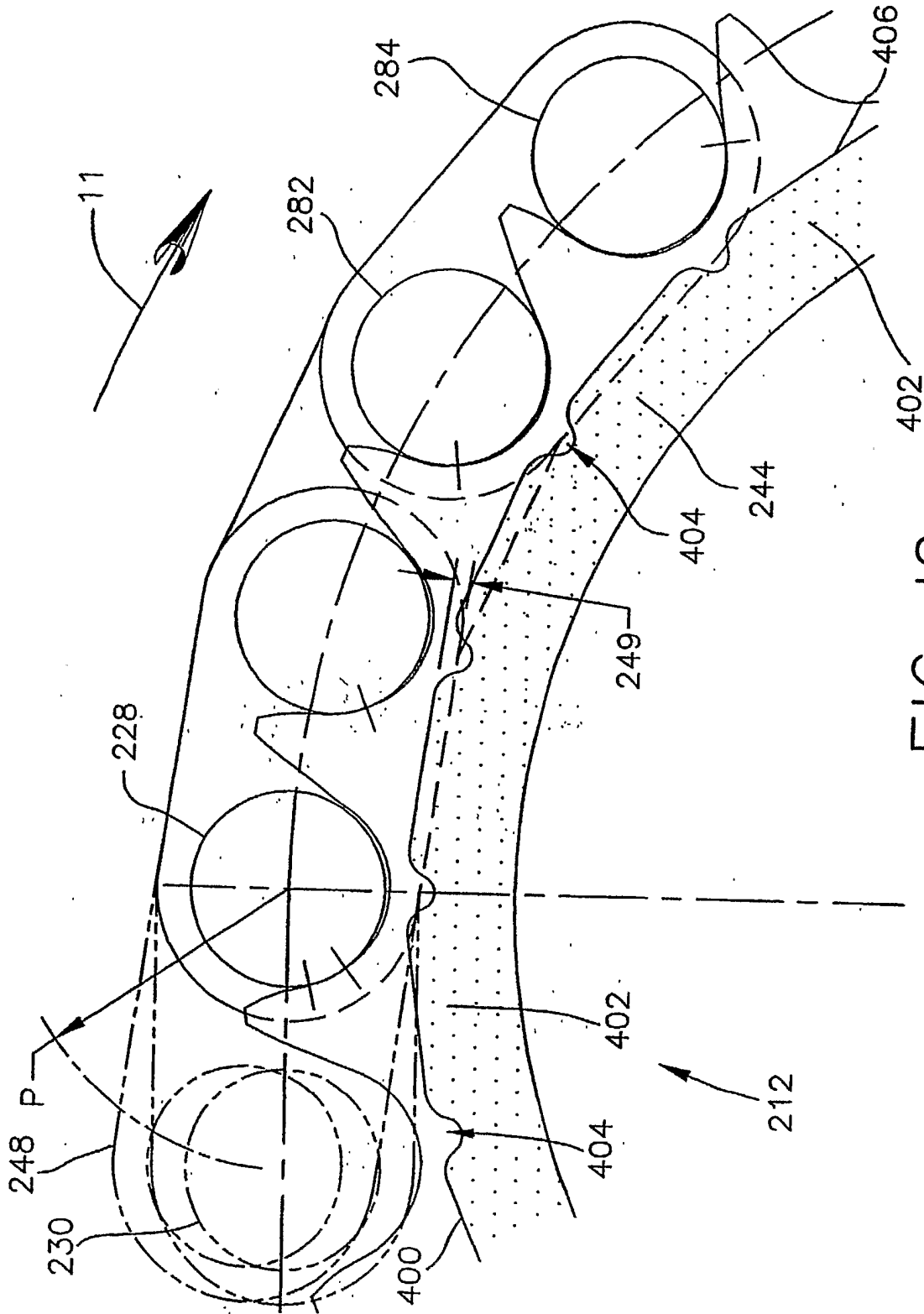

FIG. 12

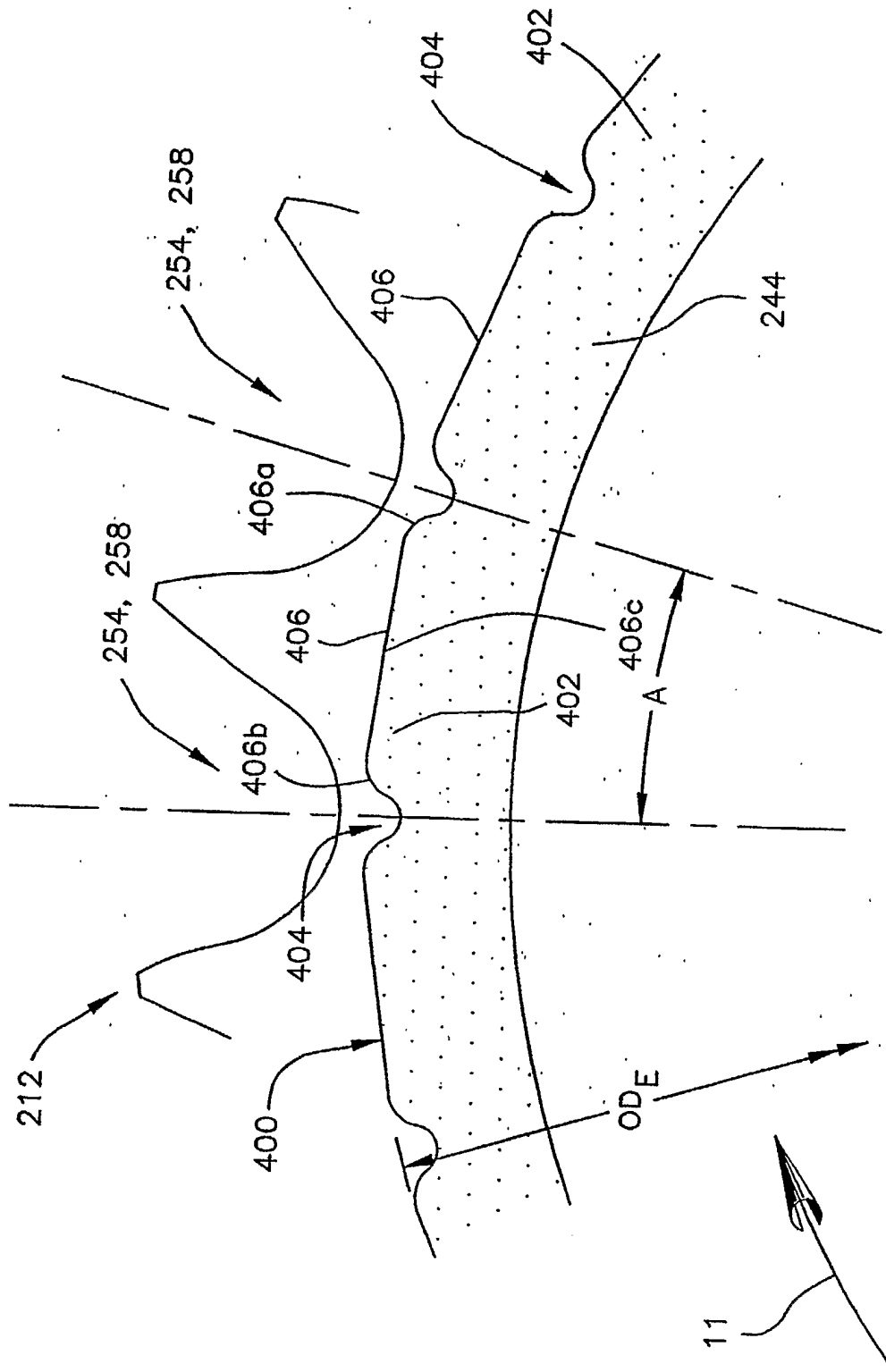

FIG. 12a

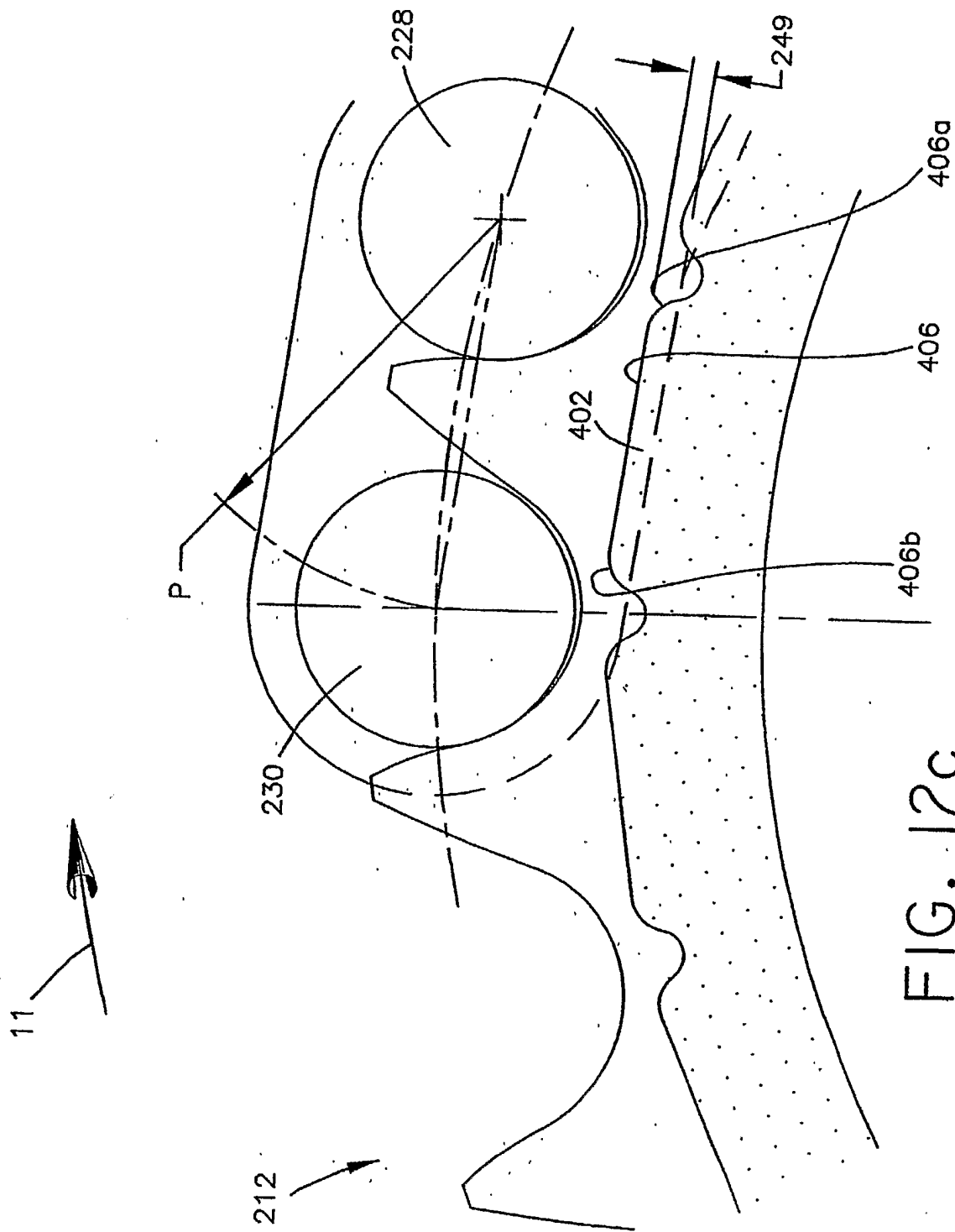

FIG. 12c

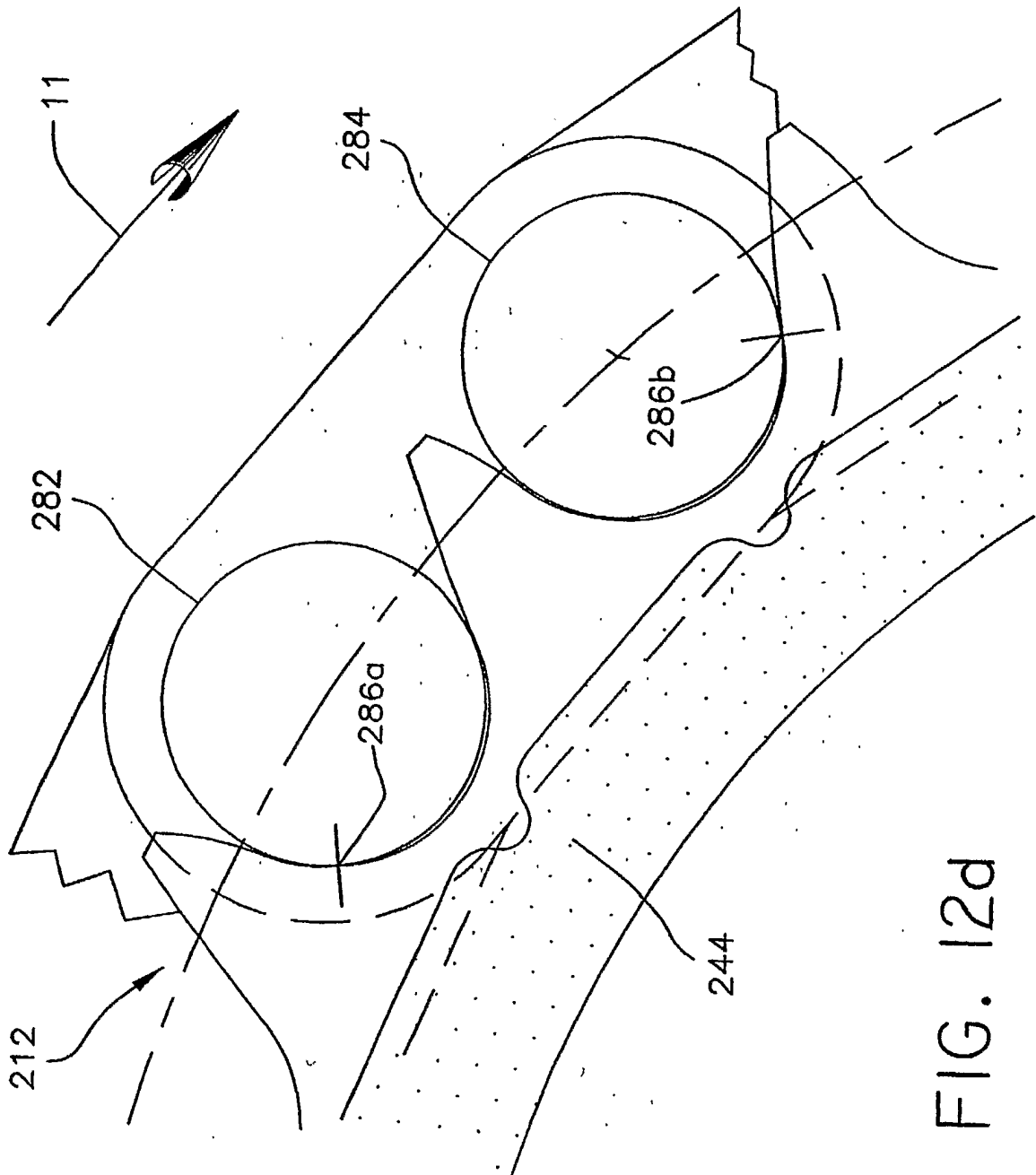

FIG. 12d

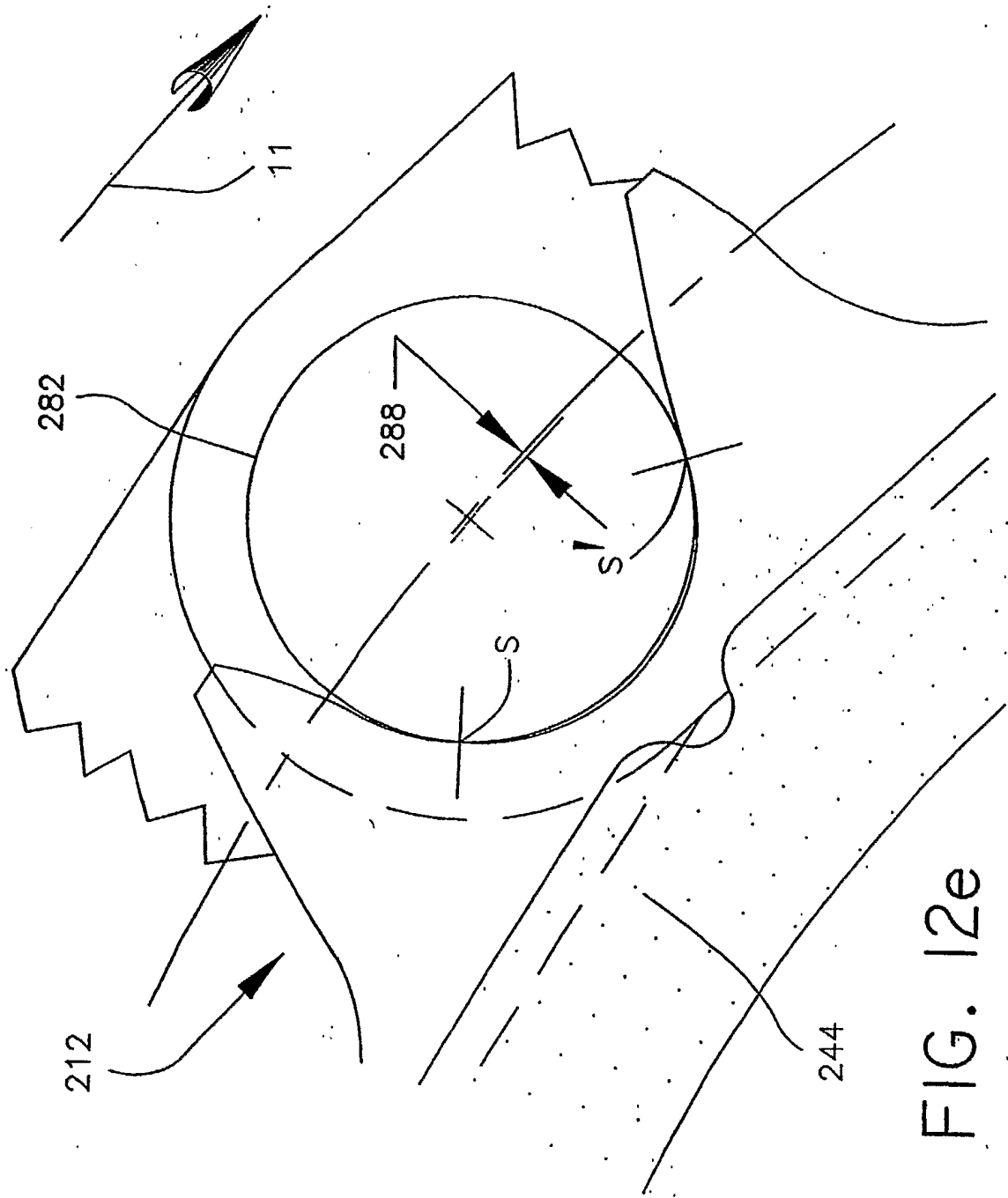

FIG. 12e

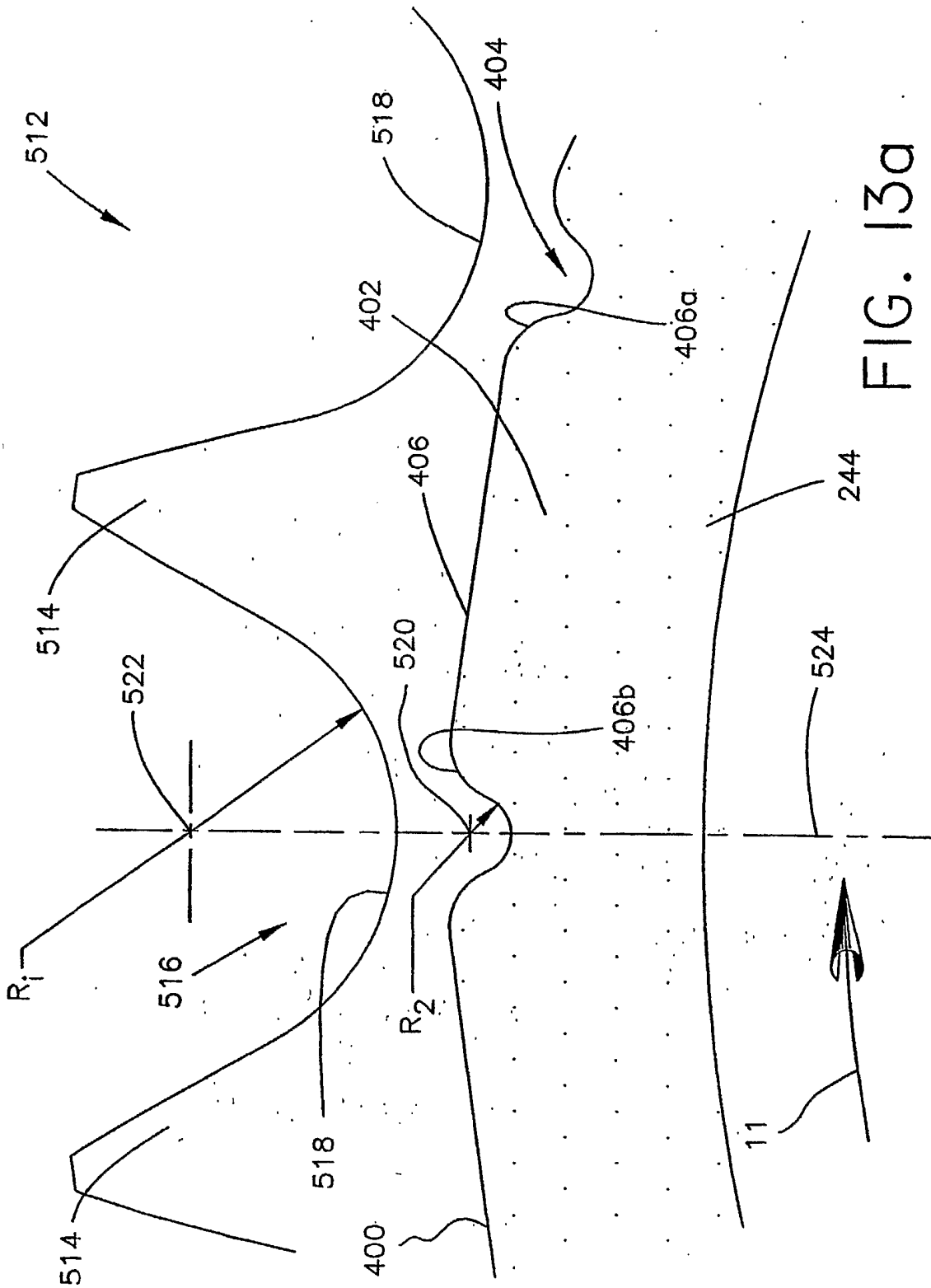

FIG. 13a

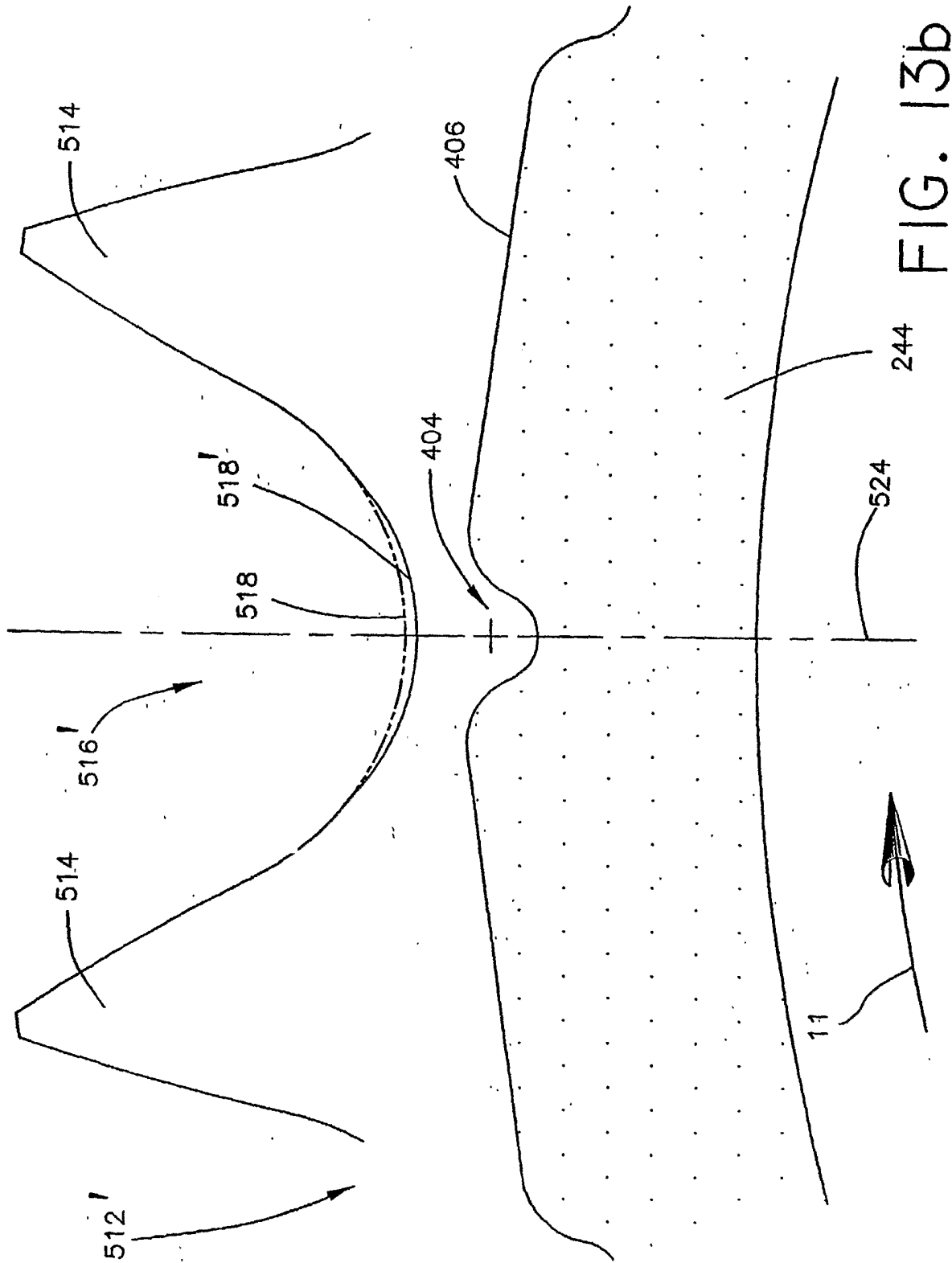

FIG. 13b

INTERNATIONAL SEARCH REPORT

International Application No
PCT/US 03/11744A. CLASSIFICATION OF SUBJECT MATTER
IPC 7 F16H55/30

According to International Patent Classification (IPC) or to both national classification and IPC

B. FIELDS SEARCHED

Minimum documentation searched (classification system followed by classification symbols)
IPC 7 F16H

Documentation searched other than minimum documentation to the extent that such documents are included in the fields searched

Electronic data base consulted during the international search (name of data base and, where practical, search terms used)

EPO-Internal, PAJ

C. DOCUMENTS CONSIDERED TO BE RELEVANT

Category °	Citation of document, with indication, where appropriate, of the relevant passages	Relevant to claim No.
X	FR 1 186 486 A (MOTOBECANE ATELIERS) 25 August 1959 (1959-08-25) page 2, right-hand column, line 11 - line 21; figure 3	1-9, 12, 13, 17-20
Y	----	10, 11, 14-16
Y	WO 00 11374 A (CLOYES GEAR & PRODUCTS INC) 2 March 2000 (2000-03-02) the whole document	10, 11, 14-16
X	----	1-5, 9, 12, 13, 17-20
A	JP 11 002312 A (NISSAN MOTOR CO LTD) 6 January 1999 (1999-01-06) figure 2	6-8, 10, 11
	----- -/--	

 Further documents are listed in the continuation of box C. Patent family members are listed in annex.

° Special categories of cited documents :

A document defining the general state of the art which is not considered to be of particular relevance

E earlier document but published on or after the international filing date

L document which may throw doubts on priority claim(s) or which is cited to establish the publication date of another citation or other special reason (as specified)

O document referring to an oral disclosure, use, exhibition or other means

P document published prior to the international filing date but later than the priority date claimed

T later document published after the international filing date or priority date and not in conflict with the application but cited to understand the principle or theory underlying the invention

X document of particular relevance; the claimed invention cannot be considered novel or cannot be considered to involve an inventive step when the document is taken alone

Y document of particular relevance; the claimed invention cannot be considered to involve an inventive step when the document is combined with one or more other such documents, such combination being obvious to a person skilled in the art.

& document member of the same patent family

Date of the actual completion of the international search

7 August 2003

Date of mailing of the international search report

18/08/2003

Name and mailing address of the ISA

European Patent Office, P.B. 5818 Patentlaan 2
NL - 2280 HV Rijswijk
Tel. (+31-70) 340-2040, Tx. 31 651 epo nl,
Fax: (+31-70) 340-3016

Authorized officer

Van Prooijen, T

INTERNATIONAL SEARCH REPORT

International Application No
PCT/US 03/11744

C.(Continuation) DOCUMENTS CONSIDERED TO BE RELEVANT		
Category °	Citation of document, with indication, where appropriate, of the relevant passages	Relevant to claim No.
X	JP 57 173649 A (YAMAHA HATSUDOKI KK) 26 October 1982 (1982-10-26) figures 7,8 -----	1, 18-20
X	DE 199 29 667 C (JOH WINKLHOFER & SOEHNE GMBH U) 18 January 2001 (2001-01-18) figures 1,2 -----	1, 19
A		18, 20

INTERNATIONAL SEARCH REPORT
Information on patent family members

International Application No
PCT/US 03/11744

Patent document cited in search report		Publication date	Patent family member(s)	Publication date
FR 1186486	A	25-08-1959	NONE	
<hr/>				
WO 0011374	A	02-03-2000	BR 9913299 A	25-09-2001
			CA 2339729 A1	02-03-2000
			EP 1108160 A1	20-06-2001
			JP 2002523698 T	30-07-2002
			WO 0011374 A1	02-03-2000
			US 2002169044 A1	14-11-2002
			US 6179741 B1	30-01-2001
			US 2001000171 A1	05-04-2001
<hr/>				
JP 11002312	A	06-01-1999	NONE	
<hr/>				
JP 57173649	A	26-10-1982	NONE	
<hr/>				
DE 19929667	C	18-01-2001	DE 19929667 C1	18-01-2001
<hr/>				