



- (51) International Patent Classification:  
**B65D 17/353** (2006.01)
- (21) International Application Number:  
PCT/US2012/047567
- (22) International Filing Date:  
20 July 2012 (20.07.2012)
- (25) Filing Language: English
- (26) Publication Language: English
- (30) Priority Data:  
61/510,262 11 August 2011 (11.08.2011) US
- (71) Applicant (for all designated States except US): **STOLLE MACHINERY COMPANY, LLC** [US/US]; 6949 South Potomac Street, Centennial, Colorado 80112 (US).
- (72) Inventors; and
- (75) Inventors/Applicants (for US only): **MCCLUNG, James A.** [US/US]; 1351 Applegrove, N.E., Canton, Ohio 44721 (US). **CARSTENS, Aaron E.** [US/US]; 10696 Meadowfields Ct., Centerville, Ohio 45458 (US). **STAMMEN, Dennis C.** [US/US]; 6775 Wellbaum Road, Brookville, Ohio 45309 (US).
- (74) Agent: **COFFIELD, Grant E.**; Eckert Seamans Cherin & Mellott, LLC, 600 Grant Street, 44th Floor, Pittsburgh, Pennsylvania 15219 (US).
- (81) Designated States (unless otherwise indicated, for every kind of national protection available): AE, AG, AL, AM,

AO, AT, AU, AZ, BA, BB, BG, BH, BR, BW, BY, BZ, CA, CH, CL, CN, CO, CR, CU, CZ, DE, DK, DM, DO, DZ, EC, EE, EG, ES, FI, GB, GD, GE, GH, GM, GT, HN, HR, HU, ID, IL, IN, IS, JP, KE, KG, KM, KN, KP, KR, KZ, LA, LC, LK, LR, LS, LT, LU, LY, MA, MD, ME, MG, MK, MN, MW, MX, MY, MZ, NA, NG, NI, NO, NZ, OM, PE, PG, PH, PL, PT, QA, RO, RS, RU, RW, SC, SD, SE, SG, SK, SL, SM, ST, SV, SY, TH, TJ, TM, TN, TR, TT, TZ, UA, UG, US, UZ, VC, VN, ZA, ZM, ZW.

- (84) Designated States (unless otherwise indicated, for every kind of regional protection available): ARIPO (BW, GH, GM, KE, LR, LS, MW, MZ, NA, RW, SD, SL, SZ, TZ, UG, ZM, ZW), Eurasian (AM, AZ, BY, KG, KZ, RU, TJ, TM), European (AL, AT, BE, BG, CH, CY, CZ, DE, DK, EE, ES, FI, FR, GB, GR, HR, HU, IE, IS, IT, LT, LU, LV, MC, MK, MT, NL, NO, PL, PT, RO, RS, SE, SI, SK, SM, TR), OAPI (BF, BJ, CF, CG, CI, CM, GA, GN, GQ, GW, ML, MR, NE, SN, TD, TG).

**Declarations under Rule 4.17:**

- as to applicant's entitlement to apply for and be granted a patent (Rule 4.17(ii))
- as to the applicant's entitlement to claim the priority of the earlier application (Rule 4.17(iii))

**Published:**

- with international search report (Art. 21(3))

(54) Title: CAN END, DOUBLE ACTION TAB THEREFOR, TOOLING ASSEMBLY, AND ASSOCIATED METHOD

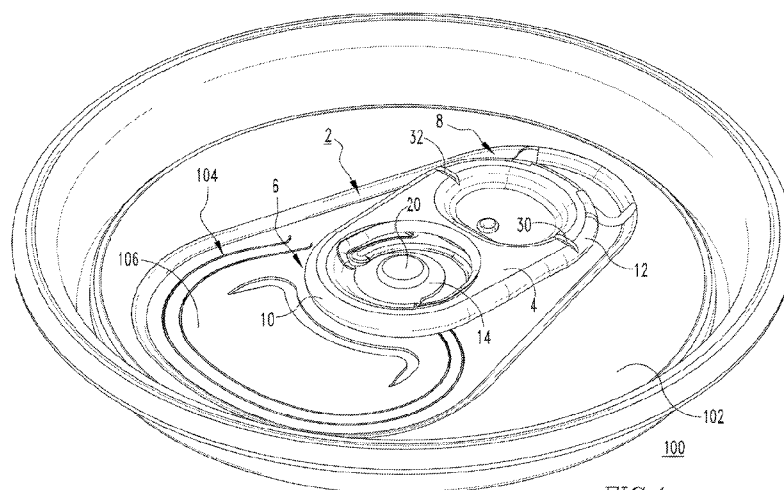

FIG. 1

(57) Abstract: A tab (2) is provided for a can end (100). The can end (100) includes an end panel (102) and a scoreline (104) defining a tear panel (106) in the end panel (102) for providing an opening in the can end (100). The tab (2) includes a body (4) having first and second opposing ends (6,8), a nose portion (10) located at or about the first end (6), a lift portion (12) located at or about the second end (8), and a rivet receiving portion (14) disposed proximate the nose portion (10). The rivet receiving portion (14) includes a rivet hole (16). A first rivet (20) extends outwardly from the end panel (102) and fastens the rivet receiving portion (14) of the tab (2) to the can end (100). A second rivet (22) extends outwardly from the end panel (102) to cooperate with a portion of the body (4) proximate the lift portion (12).



**CAN END, DOUBLE ACTION TAB THEREFOR, TOOLING ASSEMBLY,  
AND ASSOCIATED METHOD**

RELATED APPLICATION

5           This application claims the benefit of Provisional Application No. 61/510,262, filed on August 11, 2011 and entitled, "CAN END, DOUBLE ACTION TAB THEREFOR, TOOLING ASSEMBLY, AND ASSOCIATED METHOD," which is hereby incorporated herein by reference.

BACKGROUND

10 Field

The disclosed concept relates generally to containers more particularly, to can ends for containers, such as beer and beverage cans. The disclosed concept also relates to a double action tab for can ends. The disclosed concept further relates to tooling assemblies and associated methods for can ends and tabs therefor.

15 Background Information

          Metallic containers (e.g., cans) for holding products such as, for example, liquids, beverages, or food products, are typically provided with an easy open can end on which an opening mechanism, such as a pull tab, is attached (e.g., without limitation, riveted) to a tear strip or severable panel. Typically, the tear strip  
20 is defined by a scoreline in the exterior surface (e.g., public side) of the can end. The pull tab is structured to be lifted, pulled, and/or rotated to sever the scoreline and deflect the tear strip, thereby creating an opening for dispensing the contents of the can.

          When the can end is made, it originates as a can end shell, which is  
25 formed from a sheet metal product (e.g., without limitation, sheet aluminum; sheet steel). The shell is then conveyed to a conversion press, which has a number of successive tool stations. As the shell advances from one tool station to the next, conversion operations such as, for example and without limitation, rivet forming, paneling, scoring, embossing, tab securing and tab staking, are performed until the  
30 shell is fully converted into the desired can end and is discharged from the press. Typically, each tool station of the conversion press includes an upper tool member, which is structured to be advanced towards a lower tool member upon actuation of a press ram. The shell is received between the upper and lower tool members. Thus, as the upper tool member engages the shell, the upper and/or lower tool members  
35 respectively act upon the public and/or product (e.g., interior side, which faces the can

body) sides of the shell, in order to perform a number of the aforementioned conversion operations. Upon completion of a given operation, the press ram retracts the upper tool member and the partially converted shell is moved to the next successive tool station, or the tooling is changed within the same station, to perform the next conversion operation.

In the canmaking industry, there is an ongoing desire to improve the rate and manner in which the contents of the container are dispensed. Specifically, the can end design can significantly impact the pour characteristics of the can. For example, interrupted or discontinuous flow often results from the air flow and associated pressure differential between the interior and exterior of the can. As a result, glugging and/or splashing, a slower than desired pour or flow rate, and/or excessive carbonation or foaming of the dispensed liquid, can result. Prior proposals for addressing these issues suffer from various disadvantages. Among them, are complexity of design and/or multiple component pull tabs or opening mechanisms, which are costly and/or impractical to produce, or fail to achieve the desired result. Many known designs also require substantial modification or complete redesign of the can end, for example to change the geometry of the tear strip and associated opening, and/or to add a number of additional tear strips.

There is, therefore, room for improvement in containers, such as beer and beverage cans, and in can ends and tabs therefor, as well as associated tooling assemblies and methods.

### SUMMARY

These needs and others are met by embodiments of the disclosed concept, which are directed to a double action tab for can ends and containers, and associated tooling and methods. Among other benefits, the double action tab improves the rate and manner in which the contents of the container are dispensed.

As one aspect of the disclosed concept, a tab is provided for a can end. The can end includes an end panel and a scoreline defining a tear panel in the end panel for providing an opening in the can end. The tab comprises: a body including a first end and a second end disposed opposite and distal from the first end; a nose portion located at or about the first end of the tab; a lift portion located at or about the second end of the tab; a rivet receiving portion disposed proximate the nose portion, the rivet receiving portion including a rivet hole; a first rivet structured to extend

outwardly from the end panel and fasten the rivet receiving portion of the tab to the can end; and a second rivet structured to extend outwardly from the end panel to cooperate with a portion of the body proximate the lift portion.

5 A can end and can employing the aforementioned tab, and associated tooling and method are also disclosed.

#### BRIEF DESCRIPTION OF THE DRAWINGS

A full understanding of the disclosed concept can be gained from the following description of the preferred embodiments when read in conjunction with the  
10 accompanying drawings in which:

Figure 1 is an isometric view of a can end and double action tab therefor, in accordance with an embodiment of the disclosed concept;

Figure 2 is a top plan view of the can end and double action tab therefor of Figure 1;

15 Figure 3 is a section view taken along line 3-3 of Figure 2;

Figures 4A, 4B and 4C are side elevation views of the can end and double action tab therefor of Figure 3, sequentially showing the operation of the tab to open and vent a can end, in accordance with an embodiment of the disclosed  
concept;

20 Figures 5A-5E are side elevation section views showing a portion of tooling performing a sequential forming operation, in accordance with an embodiment of the disclosed concept; and

Figures 6A-6H are top plan views showing the sequential for forming a vented can end, in accordance with an embodiment of the disclosed concept.

25

#### DESCRIPTION OF THE PREFERRED EMBODIMENTS

For purposes of illustration, embodiments of the disclosed concept will be described as applied to can ends for beverage/beer cans, although it will become apparent that they could also be employed to other contains such as, for example and  
30 without limitation, cans for liquids other than beer and beverages, and food cans.

It will be appreciated that the specific elements illustrated in the figures herein and described in the following specification are simply exemplary embodiments of the disclosed concept, which are provided as non-limiting examples solely for the purpose of illustration. Therefore, specific dimensions, orientations and

other physical characteristics related to the embodiments disclosed herein are not to be considered limiting on the scope of the disclosed concept.

Directional phrases used herein, such as, for example, clockwise, counterclockwise, left, right, front, back, top, bottom, upper, lower and derivatives thereof, relate to the orientation of the elements shown in the drawings and are not limiting upon the claims unless expressly recited therein.

As employed herein, the terms “can” and “container” are used substantially interchangeably to refer to any known or suitable container, which is structured to contain a substance (e.g., without limitation, liquid; food; any other suitable substance), and expressly includes, but is not limited to, food cans, as well as beverage cans, such as beer and soda cans.

As employed herein, the term “can end” refers to the lid or closure that is structured to be coupled to a can, in order to seal the can.

As employed herein, the term “can end shell” is used substantially interchangeably with the term “can end.” The “can end shell” or simply the “shell” is the member that is acted upon and is converted by the disclosed tooling to provide the desired can end.

As employed herein, the statement that two or more parts are “coupled” together shall mean that the parts are joined together either directly or joined through one or more intermediate parts.

As employed herein, the term “number” shall mean one or an integer greater than one (i.e., a plurality).

Figure 1 shows a tab 2 for a can end 100 in accordance with one non-limiting embodiment of the disclosed concept. Among other features, the can end 100 includes an end panel 102 and a scoreline 104, which defines a tear panel 106. Accordingly, when the tab 2 is actuated (e.g., without limitation, lifted and pivoted or rotated) it will sever the scoreline 102 about the tear panel 106, and depress the tear panel 106 downward, thereby providing an opening in the can end 100 for dispensing the contents of the container or can 200 (partially shown in simplified form in phantom line drawing in Figure 3) to which the can end 100 is affixed.

Continuing to refer to Figure 1, and also to Figures 2, 3 and 4A-4C, the tab 2 in the example shown and described herein, includes a body 4 having opposing first and second ends 6,8. As shown, a nose portion 10 is located at or about the first end 6 of the tab 2, and a lift portion 12 is located at or about the second end 8 of the

tab 2. A rivet receiving portion 14 is disposed proximate the nose portion 10, and includes a rivet hole 16 (Figure 3). As best shown in the section view of Figure 3, a first rivet 20 extends outwardly from the end panel 102 and fastens the rivet receiving portion 14 of the tab 2 to the can end 100. A second rivet 22 is structured to extend  
5 outwardly from the end panel 102 to cooperate with a portion of the tab body 4 proximate the lift portion 12 of the tab 2.

More specifically, the body 4 of the tab 2 preferably further includes a recessed panel 24. The recessed panel 24 includes a rivet aperture 26 (Figures 3 and 4A-4C). The second rivet 22 extends through the rivet aperture 26 and is fastened  
10 (e.g., without limitation, staked) to the recessed panel 24 of the tab body 4, as best shown in Figure 3. Accordingly, when the lift portion 12 is lifted (e.g., pivoted counterclockwise in the direction of arrow 28 of Figure 3), the lift portion 12 of the tab 2 and, in particular, the recessed panel 24, is structured to detach the second rivet 22 from the end panel 102, thereby creating a vent opening (Figures 4B and 4C) in the  
15 can end 100. Further rotation of the tab 2 severs the scoreline 104 and opens the tear panel 106 to create the dispensing opening (Figures 4B and 4C) in the can end 100, in a generally well known manner. Operation of the tab 2 will be further appreciated with reference to the sequential steps for opening and venting the can end 100, which are shown in Figures 4A, 4B and 4C.

Accordingly, it will be appreciated that the vent opening (Figures 4B and 4C) created by the removal (e.g., without limitation, detachment) of the second rivet 22 from the end panel 102 provides the necessary ventilation to regulate (e.g.,  
20 without limitation, equalize) the air pressure between the interior of the container (see, for example and without limitation, can 200 partially shown in simplified form in phantom line drawing in Figure 3) and the exterior of the container 200 (Figure 3). Consequently, disadvantages (e.g., without limitation, glugging; slow pour rate; intermittent pouring; splashing; excessive carbonation and foaming) of prior art designs are substantially addressed and overcome, and the pour characteristics of the can end 100 are improved.

It will further be appreciated that the end panel 102 of the can end 100 may further include an additional scoreline 110, for example extending  
30 circumferentially around the base of the second rivet 22, as shown in Figures 3 and 4A-4C. Such scoreline 110 further facilitates detachment and separation of the second rivet 22 from the end panel 102 and creation of the associated vent opening

(see, for example, Figures 4B and 4C) upon actuation of the tab lift portion 12, as shown in the sequential steps of Figures 4A, 4B and 4C. Figure 4A illustrates an optional additional opening step discussed in greater detail hereinbelow.

The disclosed tab 2 can, therefore, be characterized as a “double-action tab.” That is, in a first action, namely lifting the lift portion 12 and pivoting (e.g., rotating counterclockwise in the direction of arrow 28' from the perspective of Figure 4A) the tab body 4 as shown in Figures 4A and 4B, the tab 2 detaches the second rivet 22, as shown in Figure 4B, as previously described hereinabove. In a second action, namely continued pivoting (e.g., rotation counterclockwise in the direction of arrow 28" from the perspective of Figure 4B) of the tab body 4 to the ending position of Figure 4C, the nose portion 10 of the tab 2 severs the scoreline 104 and opens the tear panel 106, as sequentially shown in Figures 4B and 4C.

Among other benefits, the tab 2 preferably comprises a single unitary piece of material as opposed to requiring a plurality of relatively complex components or pieces in accordance with known designs. The tab 2 also functions in a unique and relatively simple manner that essentially requires only one single continuous motion (see, for example, Figures 4A-4C) of the tab 2, as opposed to requiring the user to perform a number of different steps and/or movements of a plurality of different components in order to create a vent opening and open the can end. Specifically, the user merely needs to lift the lift portion 12 of the tab 2 and pivot it (e.g., without limitation, rotate counterclockwise in the direction of arrows 28, 28' and 28" from the perspectives of Figures 3, 4A and 4B, respectively) in the traditional, well known manner, in order to effectuate the aforementioned severance or detachment of the second rivet 22 (Figure 4B), as well as opening the tear panel 106 (Figure 4C).

It will be appreciated that the tab 2 may or may, but need not necessarily, include a number of additional features such as, for example and without limitation, a plurality of slots 30,32. More specifically, a longitudinal axis 300 extends through the center of the tab 2 between the first and second ends 6,8 thereof, as best shown in Figure 2. The slots 30,32 in the non-limiting example embodiment shown and described herein are disposed between the nose portion 10 and the lift portion 12 of the tab 2, on opposing sides of the tab body 4. The slots 30,32, therefore, combine to form a fulcrum 400 that extends generally transverse to the longitudinal axis 300, as shown in Figure 2. The fulcrum 400 enables the lift portion 12 to pivot upwards (see, for example, Figure 4A) and downwards (not shown) in

relation to the nose portion 10 of the tab 2. This can make it easier, for example, for the user to initially lift the lift portion 12 of the tab 2, as shown in Figure 4A, due to the enhanced flexibility of the tab 2 resulting from the slots 30,32 (only one slot 32 is shown in the sectional views of Figures 3-4C).

5                   A tooling assembly for providing the tab 2 generally includes a number of tooling stations each including a first tool member and a second tool member disposed opposite the first tool member. The first and second tool members are structured to cooperate in order to form the tab 2 having the aforementioned features. It will also be appreciated that a number of tooling stations and tool members therefor are employed within a conversion press to convert shells into finished can ends 100  
10                   having the disclosed tab 2 affixed thereto, and being ready to be affixed (e.g., without limitation, seamed) to a corresponding containers (e.g., without limitation, can bodies (see, for example, can 200 partially shown in simplified form in phantom line drawing in Figure 3)). By way of one non-limiting example, Figures 5A-5E show tooling 300  
15                   and corresponding forming operations, wherein tool members (see, for example and without limitation, first tool members 302,304 of upper tooling assembly 306 and second tool members 208,310 of lower tooling assembly 312 of Figure 5A) act on a shell to form rivets 20,22 of a can end 100.

                  A method for providing a vented can end 100 and double action tab 2  
20                   therefor, in accordance with the disclosed concept, involves the steps of forming first and second rivets 20,22 on the end panel 102 of the can end 100 using the aforementioned tooling assembly. The sequential forming steps in accordance with one non-limiting example embodiment of the disclosed concept are shown in Figures 6A-6H.

25                   In operation, when the lift portion 12 of the tab 2 is actuated (e.g., rotated counterclockwise in the direction of arrow 28 from the perspective of Figure 3) the tab 2 detaches the second rivet 22 from the end panel 102 of the can end 100 to create the vent opening in the can end 100, thereby enhancing the pour characteristics of the can end 100 as described hereinabove.

30                   While specific embodiments of the disclosed concept have been described in detail, it will be appreciated by those skilled in the art that various modifications and alternatives to those details could be developed in light of the overall teachings of the disclosure. Accordingly, the particular arrangements disclosed are meant to be illustrative only and not limiting as to the scope of the

disclosed concept which is to be given the full breadth of the claims appended and any and all equivalents thereof.

What is claimed is:

1. A tab (2) for a can end (100), the can end (100) comprising an end panel (102) and a scoreline (104) defining a tear panel (106) in the end panel (102) for providing an opening in the can end (100), the tab (2) comprising:
  - a body (4) including a first end (6) and a second end (8) disposed opposite and distal from the first end (6);
  - a nose portion (10) located at or about the first end (6) of the tab (2);
  - a lift portion (12) located at or about the second end (8) of the tab (2);
  - a rivet receiving portion (14) disposed proximate the nose portion (10), the rivet receiving portion (14) including a rivet hole (16);
  - a first rivet (20) structured to extend outwardly from the end panel (102) and fasten the rivet receiving portion (14) of the tab (2) to the can end (100);
  - and
  - a second rivet (22) structured to extend outwardly from the end panel (102) to cooperate with a portion of the body (4) proximate the lift portion (12).
2. The tab (2) of claim 1 wherein the end panel (102) further comprises an additional scoreline (104) proximate the second rivet (22); and wherein the lift portion (12) is structured to pivot about the second rivet (22), thereby at least partially severing the additional scoreline (104) to vent the can end (100).
3. The tab (2) of claim 2 wherein the additional scoreline (104) extends circumferentially around the second rivet (22).
4. The tab (2) of claim 3 wherein, when the lift portion (12) is lifted, the lift portion (12) is structured to detach the second rivet (22) from the end panel (102), thereby creating a vent opening in the can end (100).
5. The tab (2) of claim 1 wherein the body (4) further comprises a recessed panel (24); wherein the recessed panel (24) includes a rivet aperture (26); and wherein the second rivet (22) is structured to extend through the rivet aperture (26) and be fastened to the recessed panel (24).

6. The tab (2) of claim 1 wherein the body (4) further comprises a longitudinal axis (300) extending through the center of the tab (2) between the first end (6) and the second end (8), and a plurality of slots (30,32); wherein the slots (30,32) are disposed between the nose portion (10) and the lift portion (12) on opposing sides of the tab (2); wherein the slots (30,32) combine to form a fulcrum (400) that extends generally transverse to the longitudinal axis (300); and wherein the fulcrum (400) enables the lift portion (12) to pivot upwards and downwards in relation to the nose portion (10).

7. The tab (2) of claim 1 wherein the tab (2) comprises a single unitary piece of metal.

8. The tab (2) of claim 1 in combination with a can end (100) affixed to the tab (2).

9. The combination of claim 8, wherein the can end (100) is selected from the group consisting of beer can ends, beverage can ends and food can ends.

10. A tooling assembly (300) for providing a tab (2) according to any of claims 1-9, the tab (2) being structured to be affixed to a can end (100), the can end (100) comprising an end panel (102) and a scoreline (104) defining a tear panel (106) in the end panel (102) for providing an opening in the can end (100), the tooling assembly (300) comprising:

a first tool member (302); and

a second tool member (308) disposed opposite the first tool member (302), the second tool member (308) being structured to cooperate with the first tool member (302) in order to create the tab (2).

11. A method of providing a vented can end (100), the method comprising:  
forming a tab (2), the tab (2) comprising:

a body (4) including a first end (6) and a second end (8)

disposed opposite and distal from the first end (6),

a nose portion (10) located at or about the first end (6) of the tab (2),

a lift portion (12) located at or about the second end (8) of the tab (2), and

a rivet receiving portion (14) disposed proximate the nose portion (10), the rivet receiving portion (14) including a rivet hole (16),

forming a first rivet (20) on an end panel (102) of the can end (100), the end panel (102) including a public side, a product side, and a scoreline (104) in the public side for defining a tear panel (106) in the end panel (102) for providing an opening in the can end (100), the first rivet (20) extending outwardly from the public side to fasten the rivet receiving portion (14) of the tab (2) to the can end (100); and

forming a second rivet (22) on the end panel (102), the second rivet (22) extending outwardly from the public side and cooperating with another portion of the tab (2), the end panel (102) further including an additional scoreline (104) proximate the second rivet (22),

wherein, responsive to lifting the lift portion (12) of the tab (2), the tab pivots about the second rivet (22), thereby at least partially severing the additional scoreline (104) to vent the can end (100).

12. The method of claim 11 wherein, when the lift portion (12) of the tab (2) is lifted, the lift portion (12) is structured to detach the second rivet (22) from the end panel (102), thereby creating a vent opening in the can end (100).

13. The method of claim 11 wherein the body (4) of the tab (2) further comprises a recessed panel (24); wherein the recessed panel (24) includes a rivet aperture (26); and wherein the second rivet (22) extends through the rivet aperture (26) and be fastened to the recessed panel (24).

14. The method of claim 11 wherein the body (4) of the tab (2) further comprises a longitudinal axis (300) extending through the center of the tab (2) between the first end (6) and the second end (8), and a plurality of slots (30,32); wherein the slots (30,32) are disposed between the nose portion (10) and the lift portion (12) on opposing sides of the tab (2); wherein the slots (30,32) combine to form a fulcrum (400) that extends generally transverse to the longitudinal axis (300); and wherein the fulcrum (400) enables the lift portion (12) to pivot upwards and downwards in relation to the nose portion (10).

15. The method of claim 11 wherein the tab (2) comprises a single unitary piece of metal.



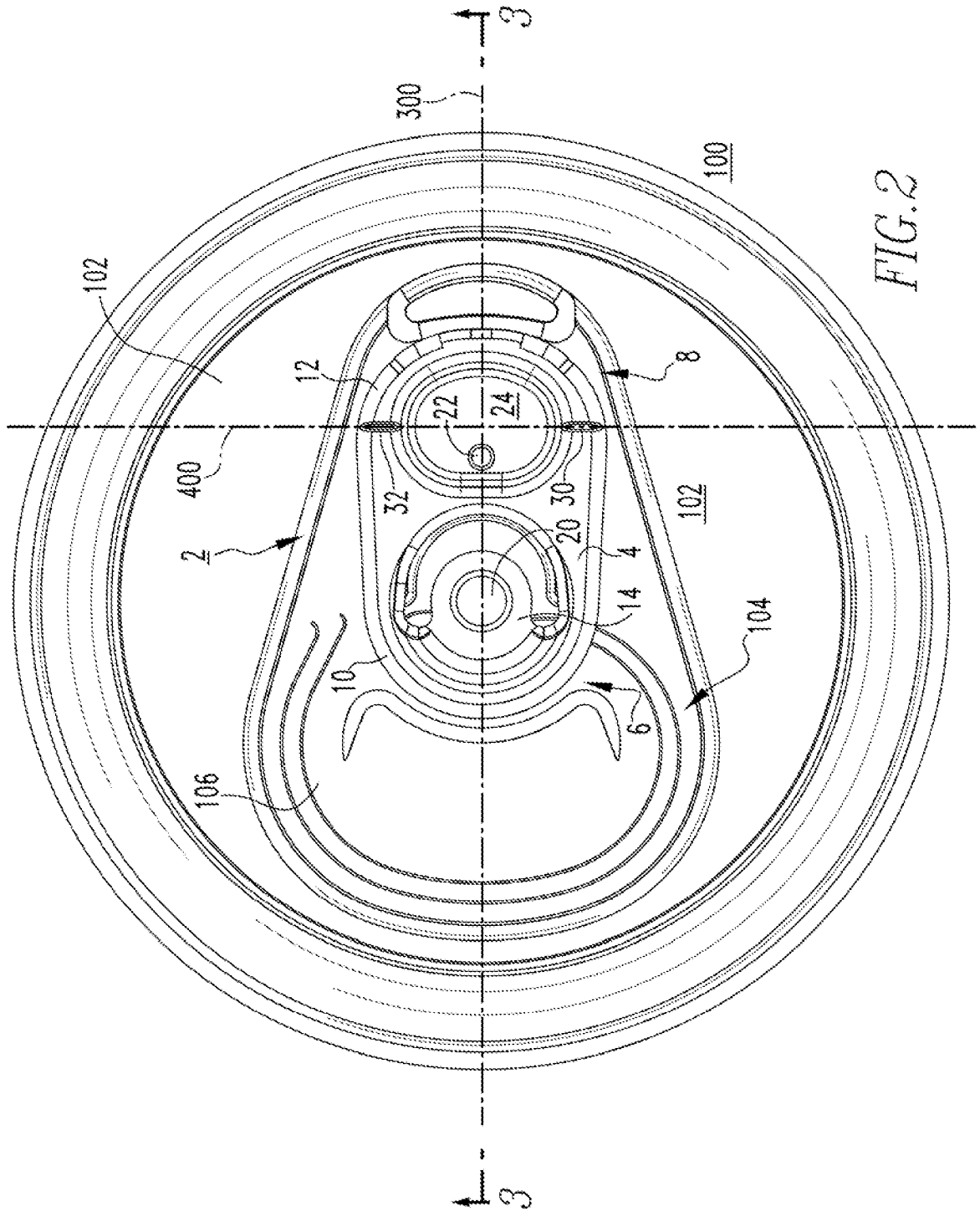

FIG. 2

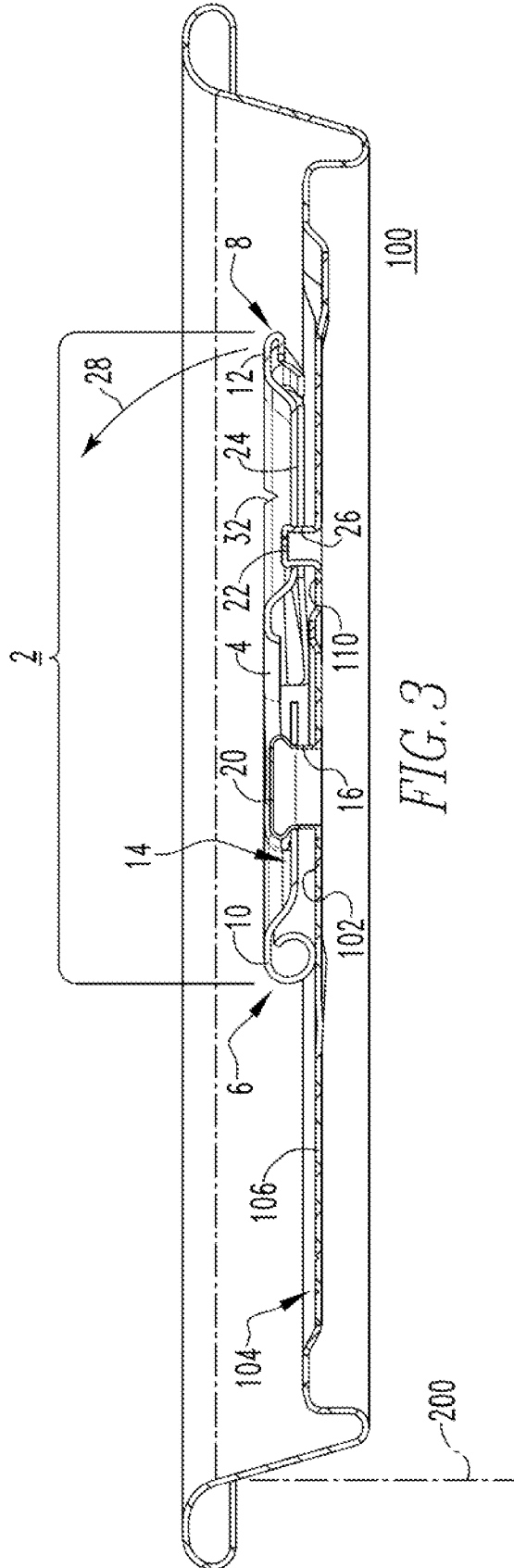
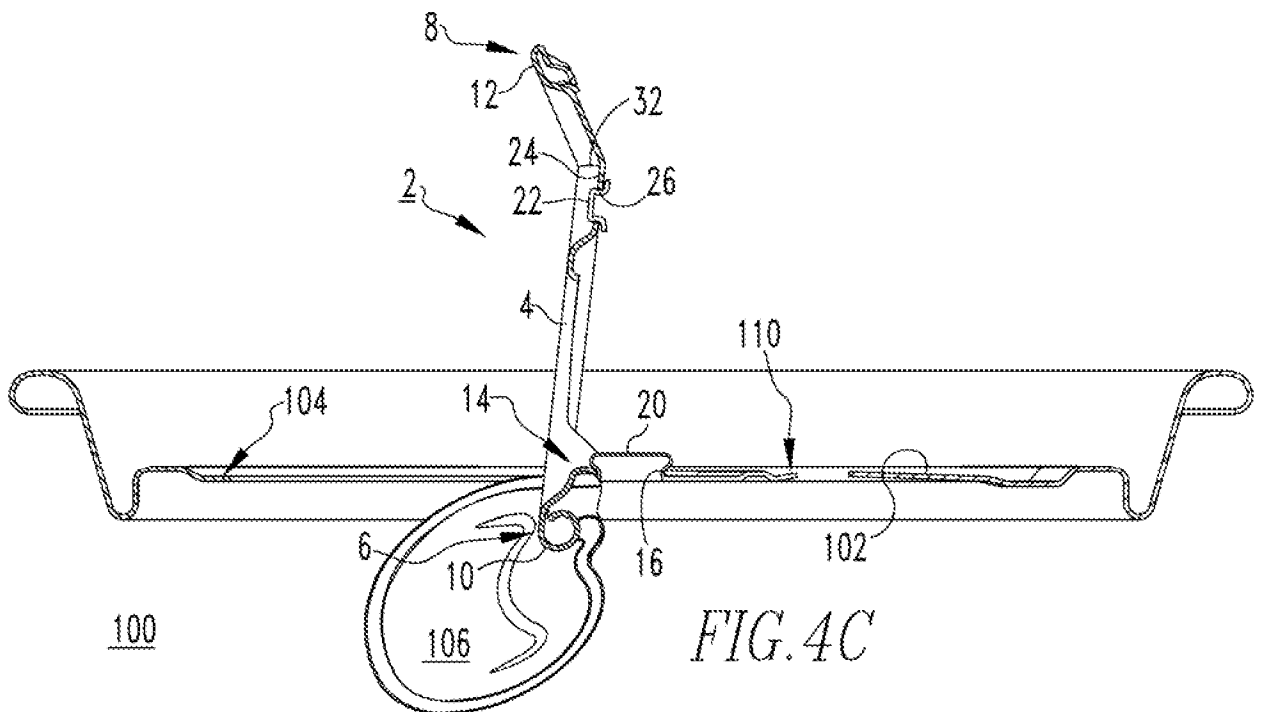
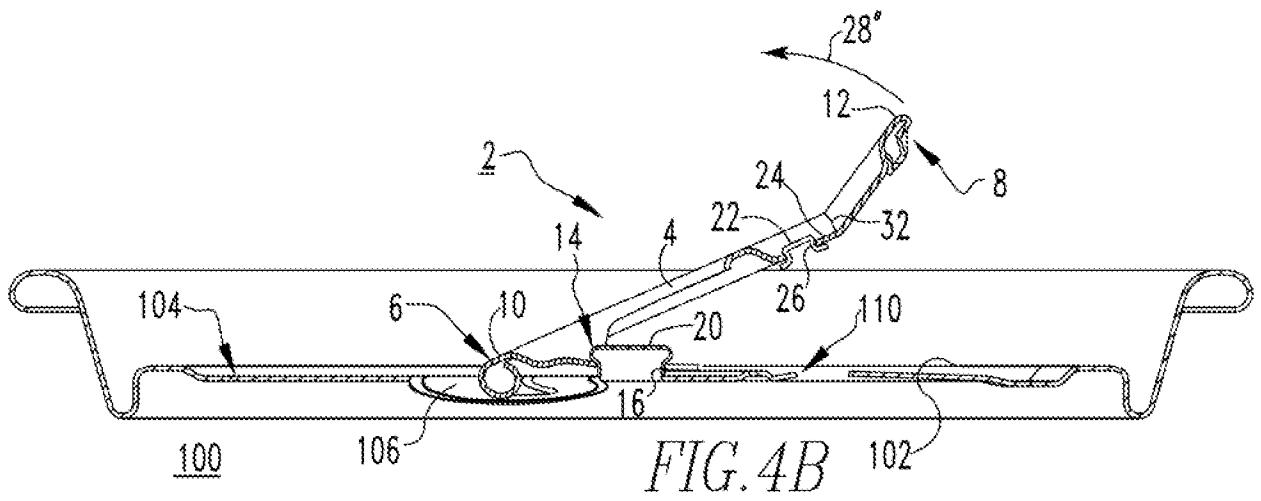
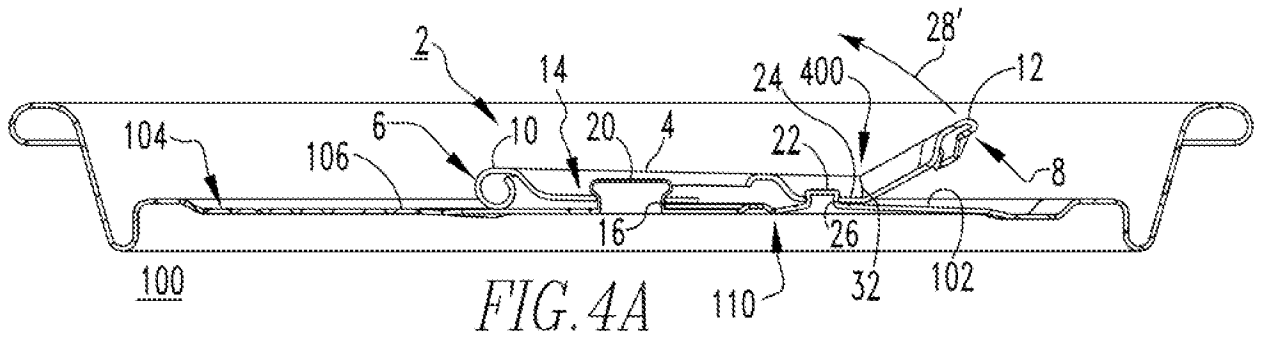
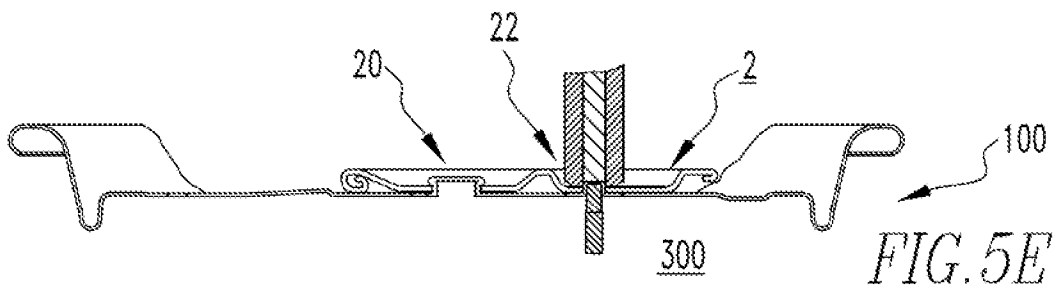
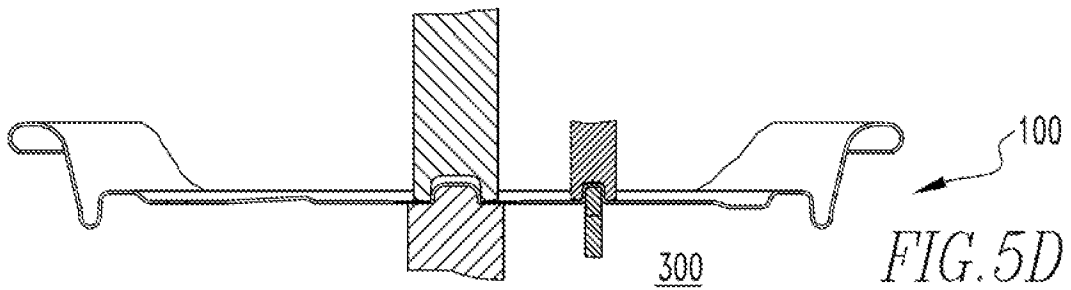
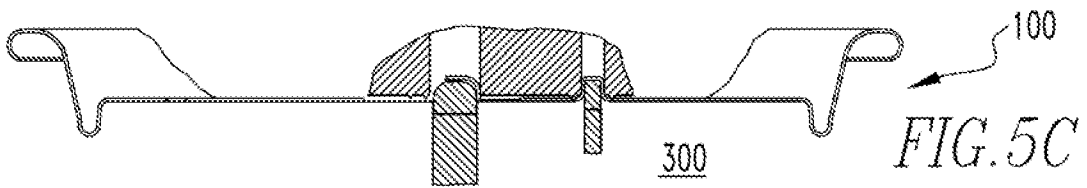
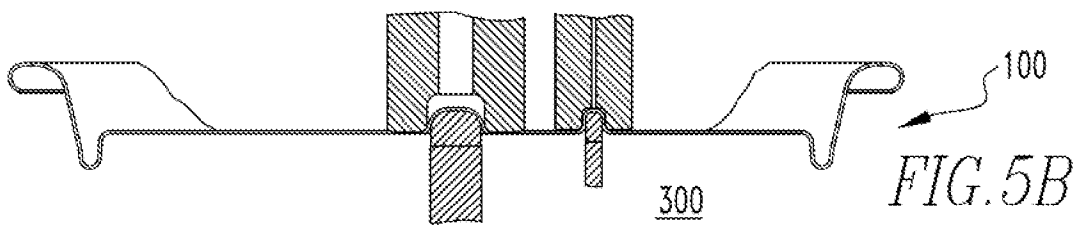
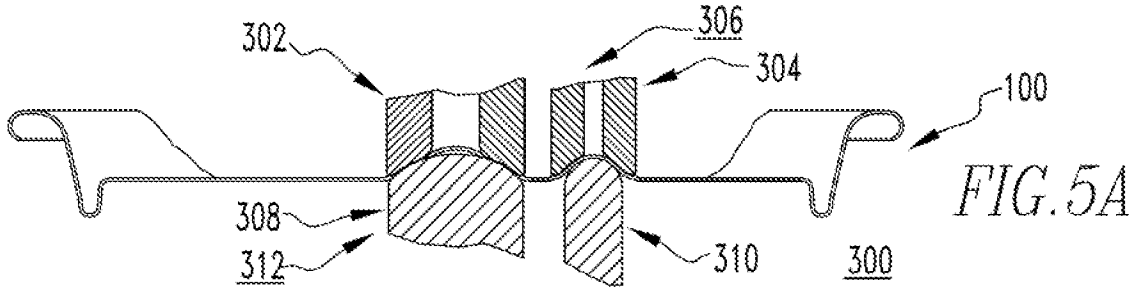
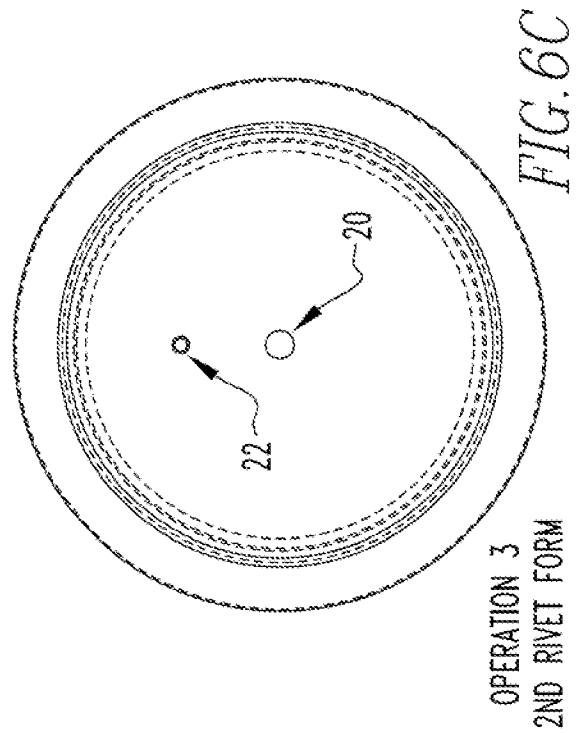
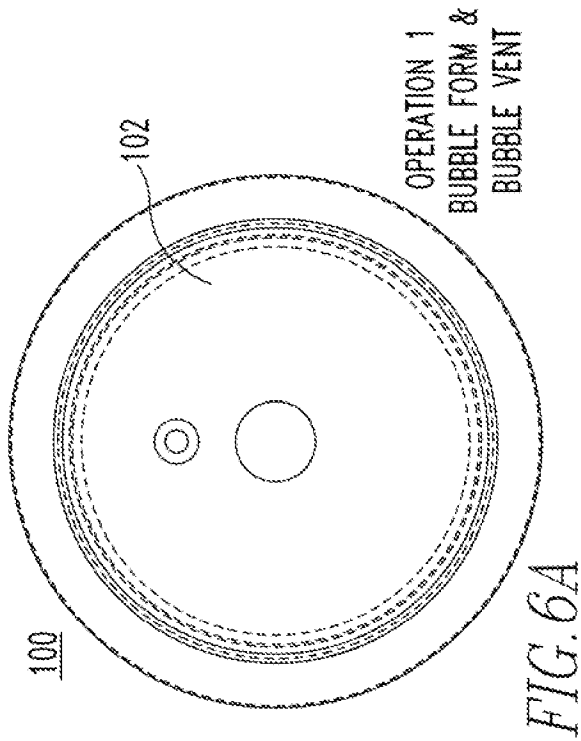
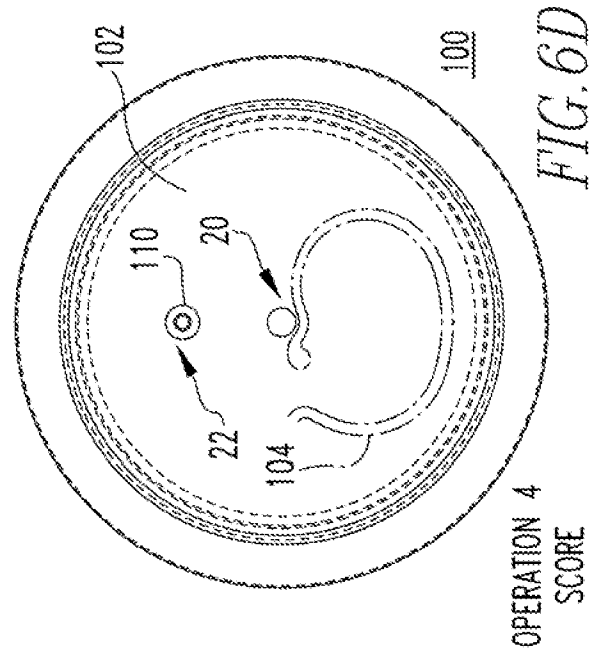
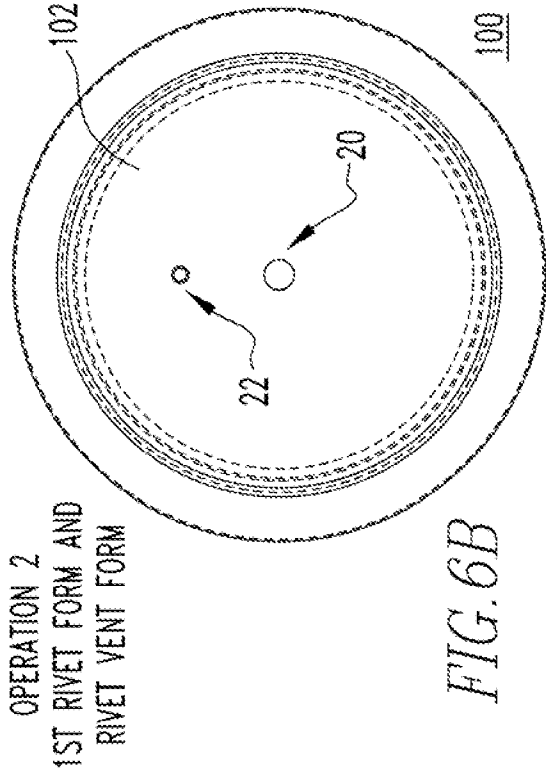

FIG. 3



5/7





OPERATION 5  
3RD RIVET FORM  
AND PANEL

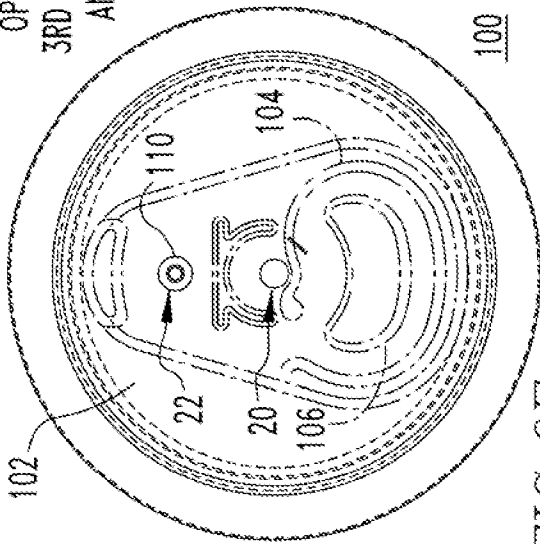

FIG. 6E

OPERATION 7  
BLANK LETTERING  
RIVET RESTRIKE AND  
RIVET VENT STAKE

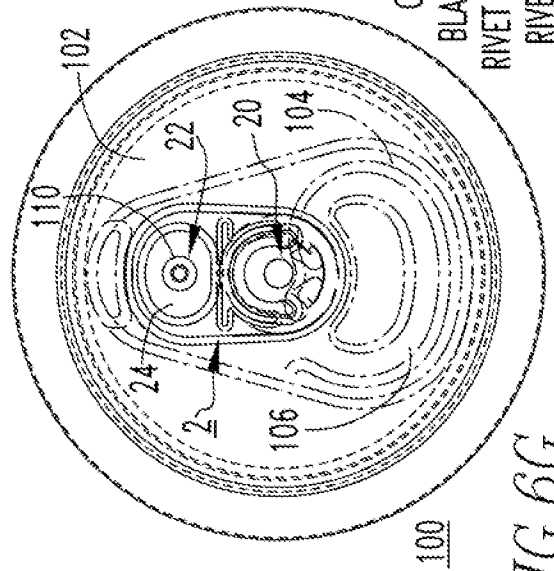

FIG. 6G

OPERATION 6  
STAKE TAB TO END

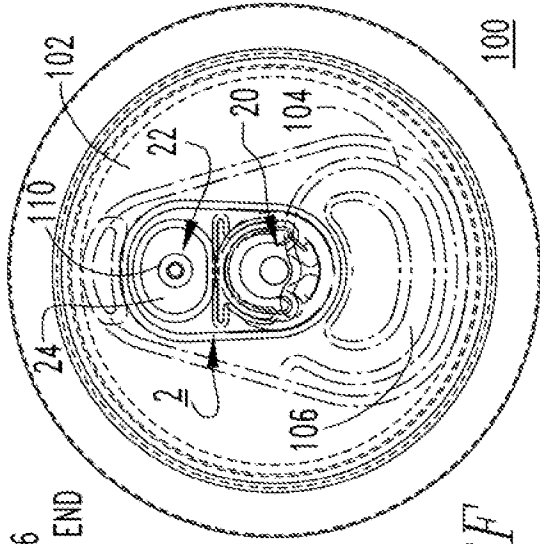

FIG. 6F

OPERATION 8  
TAB EAR WIPEDOWN

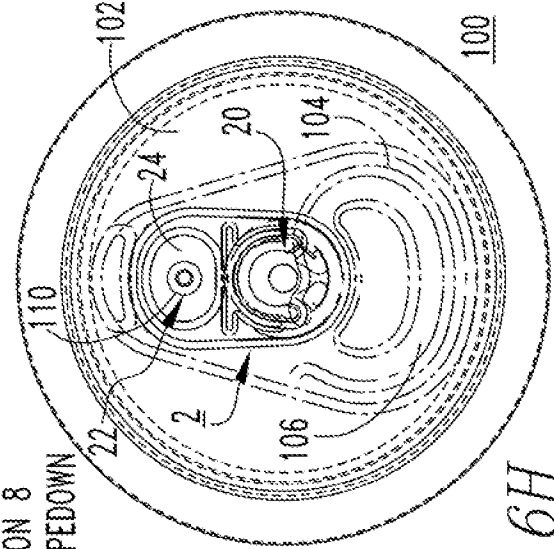

FIG. 6H

**INTERNATIONAL SEARCH REPORT**

International application No.

PCT/US2012/047567

<p><b>A. CLASSIFICATION OF SUBJECT MATTER</b>                  IPC(8) - B65D 17/353 (2012.01)                  USPC - 220/272                  According to International Patent Classification (IPC) or to both national classification and IPC</p>														
<p><b>B. FIELDS SEARCHED</b></p> <p>Minimum documentation searched (classification system followed by classification symbols)                  IPC(8) - B65D 17/353 (2012.01)                  USPC - 53/133.8, 412; 206/139; 215/216, 250, 254, 254, 258; 220/269, 270, 272; 222/153.07; D9/416, 438</p> <p>Documentation searched other than minimum documentation to the extent that such documents are included in the fields searched</p> <p>Electronic data base consulted during the international search (name of data base and, where practicable, search terms used)                  PatBase, Google Patents</p>														
<p><b>C. DOCUMENTS CONSIDERED TO BE RELEVANT</b></p> <table border="1"> <thead> <tr> <th>Category*</th> <th>Citation of document, with indication, where appropriate, of the relevant passages</th> <th>Relevant to claim No.</th> </tr> </thead> <tbody> <tr> <td>Y</td> <td>US 2009/0095752 A1 (MCELDOWNEY et al) 16 April 2009 (16.04.2009) entire document</td> <td>1-15</td> </tr> <tr> <td>Y</td> <td>US 3,477,608 A (FRAZE) 11 November 1969 (11.11.1969) entire document</td> <td>1-15</td> </tr> <tr> <td>A</td> <td>US 2008/0314906 A1 (BUTCHER et al) 25 December 2008 (25.12.2008) entire document</td> <td>1-15</td> </tr> </tbody> </table>			Category*	Citation of document, with indication, where appropriate, of the relevant passages	Relevant to claim No.	Y	US 2009/0095752 A1 (MCELDOWNEY et al) 16 April 2009 (16.04.2009) entire document	1-15	Y	US 3,477,608 A (FRAZE) 11 November 1969 (11.11.1969) entire document	1-15	A	US 2008/0314906 A1 (BUTCHER et al) 25 December 2008 (25.12.2008) entire document	1-15
Category*	Citation of document, with indication, where appropriate, of the relevant passages	Relevant to claim No.												
Y	US 2009/0095752 A1 (MCELDOWNEY et al) 16 April 2009 (16.04.2009) entire document	1-15												
Y	US 3,477,608 A (FRAZE) 11 November 1969 (11.11.1969) entire document	1-15												
A	US 2008/0314906 A1 (BUTCHER et al) 25 December 2008 (25.12.2008) entire document	1-15												
<p><input type="checkbox"/> Further documents are listed in the continuation of Box C. <input type="checkbox"/></p>														
<p>* Special categories of cited documents:</p> <table border="0"> <tr> <td> <p>"A" document defining the general state of the art which is not considered to be of particular relevance</p> <p>"E" earlier application or patent but published on or after the international filing date</p> <p>"L" document which may throw doubts on priority claim(s) or which is cited to establish the publication date of another citation or other special reason (as specified)</p> <p>"O" document referring to an oral disclosure, use, exhibition or other means</p> <p>"P" document published prior to the international filing date but later than the priority date claimed</p> </td> <td> <p>"T" later document published after the international filing date or priority date and not in conflict with the application but cited to understand the principle or theory underlying the invention</p> <p>"X" document of particular relevance; the claimed invention cannot be considered novel or cannot be considered to involve an inventive step when the document is taken alone</p> <p>"Y" document of particular relevance; the claimed invention cannot be considered to involve an inventive step when the document is combined with one or more other such documents, such combination being obvious to a person skilled in the art</p> <p>"&amp;" document member of the same patent family</p> </td> </tr> </table>			<p>"A" document defining the general state of the art which is not considered to be of particular relevance</p> <p>"E" earlier application or patent but published on or after the international filing date</p> <p>"L" document which may throw doubts on priority claim(s) or which is cited to establish the publication date of another citation or other special reason (as specified)</p> <p>"O" document referring to an oral disclosure, use, exhibition or other means</p> <p>"P" document published prior to the international filing date but later than the priority date claimed</p>	<p>"T" later document published after the international filing date or priority date and not in conflict with the application but cited to understand the principle or theory underlying the invention</p> <p>"X" document of particular relevance; the claimed invention cannot be considered novel or cannot be considered to involve an inventive step when the document is taken alone</p> <p>"Y" document of particular relevance; the claimed invention cannot be considered to involve an inventive step when the document is combined with one or more other such documents, such combination being obvious to a person skilled in the art</p> <p>"&amp;" document member of the same patent family</p>										
<p>"A" document defining the general state of the art which is not considered to be of particular relevance</p> <p>"E" earlier application or patent but published on or after the international filing date</p> <p>"L" document which may throw doubts on priority claim(s) or which is cited to establish the publication date of another citation or other special reason (as specified)</p> <p>"O" document referring to an oral disclosure, use, exhibition or other means</p> <p>"P" document published prior to the international filing date but later than the priority date claimed</p>	<p>"T" later document published after the international filing date or priority date and not in conflict with the application but cited to understand the principle or theory underlying the invention</p> <p>"X" document of particular relevance; the claimed invention cannot be considered novel or cannot be considered to involve an inventive step when the document is taken alone</p> <p>"Y" document of particular relevance; the claimed invention cannot be considered to involve an inventive step when the document is combined with one or more other such documents, such combination being obvious to a person skilled in the art</p> <p>"&amp;" document member of the same patent family</p>													
<p>Date of the actual completion of the international search</p> <p>26 September 2012</p>		<p>Date of mailing of the international search report</p> <p><b>15 OCT 2012</b></p>												
<p>Name and mailing address of the ISA/US</p> <p>Mail Stop PCT, Attn: ISA/US, Commissioner for Patents                  P.O. Box 1450, Alexandria, Virginia 22313-1450                  Facsimile No. 571-273-3201</p>		<p>Authorized officer:</p> <p>Blaine R. Copenheaver</p> <p>PCT Helpdesk: 571-272-4300                  PCT OSP: 571-272-7774</p>												