

J. F. POND.

Gas Fixture.

No. 104,197.

Patented June 14, 1870.

FIG. 1

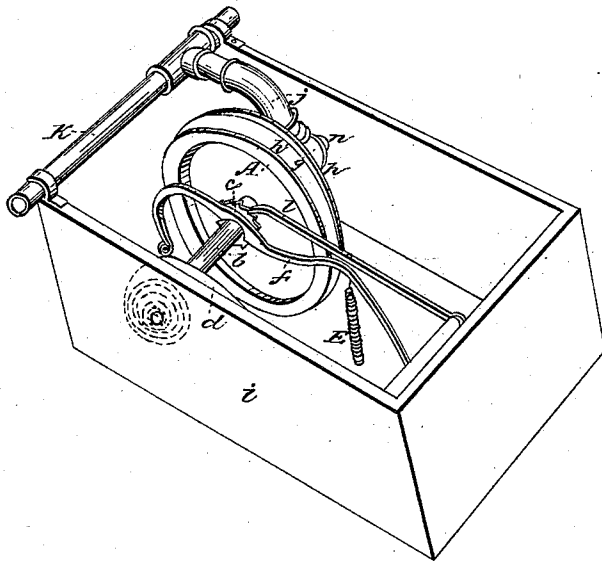

FIG. 2

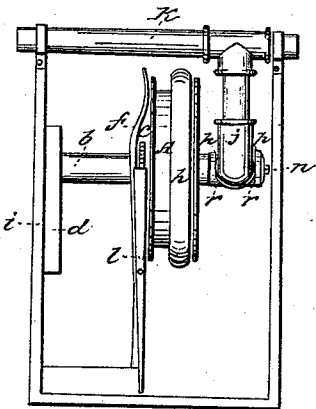
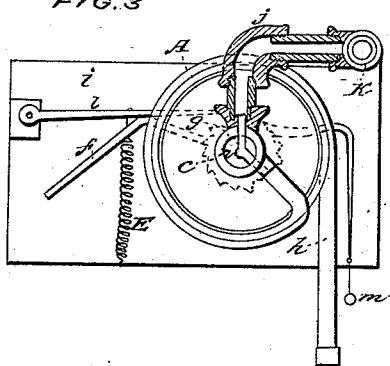

FIG. 3



WITNESSES.

O. A. Barber
G. M. Barber

INVENTOR:

Joseph F. Pond

United States Patent Office.

JOSEPH F. POND, OF CLEVELAND, OHIO.

Letters Patent No. 104,197, dated June 14, 1870; antedated June 1, 1870.

IMPROVEMENT IN DEVICE FOR RAISING AND LOWERING GAS-FIXTURES.

The Schedule referred to in these Letters Patent and making part of the same.

To all whom it may concern :

Be it known that I, JOSEPH F. POND, of Cleveland, in the county of Cuyahoga and State of Ohio, have invented a new and useful Improvement in Portable Oil and Gas-Fixtures; and the following is a description of the same, reference being had to the accompanying drawings, making a part of this specification, in which—

Figure 1 is a perspective view of the mechanism for lowering and raising oil and gas-fixtures.

Figure 2 is a plan view of fig. 1.

Figure 3 is a longitudinal section of fig. 1.

My invention consists, first, in constructing a piece of mechanism, in the manner hereinafter described, which can be placed between the ceiling and floor for the purpose of lowering and raising lamp and gas-fixtures to any desired height, so that the light reflected from the burners can be brought down as near the floor as desired, and also in the use and application of yielding collar or collars, or bearings, upon swing-joints, and keys to shut off gas in gas-fixtures, to prevent the escape of gas through the joint, and yet allow the joint to be easily adjusted.

To enable others skilled in the art to make and use my invention, I will describe it more fully referring to the drawings and letters marked thereon.

I make a box or vat of wood and metal, or of either, of sufficient size to contain a drum or pulley, A, and shaft, b, ratchet-wheel, c, and spring, d, pawl and spiral spring, e, lever, f, swing-joint, g, and flexible tube, h.

The box or vat supports and protects the mechanism and flexible tube from being injured by rats or mice. The shaft, when fitted for gas, has a bearing at one end, in the side of the box or vat, i, and the opposite end is secured and held to its place by being connected to a pipe, j, which is connected to the main-pipe, k. The shaft has a drum or pulley secured to it, near one end, which the flexible tube h passes around. A ratchet-wheel, c, is secured to the shaft near the pulley A, for the purpose of holding the pulley, and fixtures attached, to any desired place, by the aid of the pawl l, operating upon the ratchet-wheel. Attached to the shaft b is a spring, resembling a clock-spring, which

holds the burners up, and raises them when the pawl is raised from ratchet, by the lever f, by pulling gently down on a wire, m, as shown in fig. 3. Attached to the shaft is a flexible tube, which passes through an opening in the periphery of the drum A, and around the drum or pulley down through the bottom of the box i, and through the ceiling to which the lamps or gas fixtures are attached.

One end of the shaft is fitted for a swing-joint, with a male center, n, which passes through the female center, g, with a groove around, or in which the gas passes into the flexible tube to the burners. On this shaft or axle b are secured yielding washers or gaskets, p, of rubber, which are compressed between the hub or shoulder of the shaft and washer r, as shown in fig. 2 by red lines, which are forced against the side of the female portion of the swing-joint g, so that the gas cannot escape, and yet allow the joint to act easily. The yielding collar p and friction-washer r may be applied to one or both sides of the female portion of the swing-joint g, or to keys for shutting off gas in gas-fixtures, which, when applied thereto, make a right angle surface or joint, and more effectually prevent the gas from escaping, as it has two surfaces or joints to pass through, instead of one, as is usually found in gas-fixtures.

Having thus described my invention,

What I claim as new, and desire to secure by Letters Patent, is—

1. The combination of the revolving drum or cylinder A, secured to shaft b, flexible tube h, spring d, ratchet c, brake f, pawl l, spring e, and swing-joint g, secured in box i, when arranged to operate in the manner and for the purposes set forth.

2. The friction-washer r, and rubber gasket p, when applied to swing-joints and keys for gas-fixtures to prevent friction on the key or joint, and more effectually prevent the escape of gas, as and for the purposes specified.

JOSEPH F. POND.

Witnesses:

P. A. SEARLES,
G. M. BARBER.