

(19) **DANMARK**

(10) **DK/EP 2007938 T3**



Patent- og
Varemærkestyrelsen

(12) **Oversættelse af
europæisk patentskrift**

-
- (51) Int.Cl.: **D 06 F 39/02 (2006.01)** **A 47 L 15/44 (2006.01)**
- (45) Oversættelsen bekendtgjort den: **2018-12-10**
- (80) Dato for Den Europæiske Patentmyndigheds bekendtgørelse om meddelelse af patentet: **2018-09-12**
- (86) Europæisk ansøgning nr.: **07815099.2**
- (86) Europæisk indleveringsdag: **2007-03-16**
- (87) Den europæiske ansøgnings publiceringsdag: **2008-12-31**
- (86) International ansøgning nr.: **US2007064200**
- (87) Internationalt publikationsnr.: **WO2007146458**
- (30) Prioritet: **2006-03-30 US 787583 P**
- (84) Designerede stater: **AT BE BG CH CY CZ DE DK EE ES FI FR GB GR HU IE IS IT LI LT LU LV MC MT NL PL PT RO SE SI SK TR**
- (73) Patenthaver: **Diversey, Inc., 8310 16th Street, M/S 509 , P.O. Box 902, Sturtevant, WI 53177-0902, USA**
- (72) Opfinder: **LIVINGSTON, James, W., 32505 Forward Road, Manton, California 96059, USA**
STEED, Michael, A., 303 San Juan Avenue, Santa Cruz, California 95062, USA
ALHART, Scott, D., E., 2584 Gary Drive, Soquel, California 95073, USA
- (74) Fuldmægtig i Danmark: **Patrade A/S, Ceresbyen 75, 8000 Århus C, Danmark**
- (54) Benævnelse: **Udleverings- og fordelersystem til pulverformede og væskeformede kemikalier**
- (56) Fremdragne publikationer:
WO-A-2005/068060
DE-A1- 10 103 091
GB-A- 2 348 709
US-A- 3 570 717
US-A1- 2005 229 652

DESCRIPTION

TECHNICAL FIELD

[0001] The embodiments disclosed herein relate to chemical distribution systems and in particular to a system and method for dispensing and distributing liquid and powdered chemicals to washers.

BACKGROUND

[0002] Many industries require the frequent use of accurate dosages of chemicals. These industries include the on premise laundry (OPL) and machine ware wash (MWW) industries, where large volumes of chemicals are used daily. As these chemicals are consumed, new chemicals must be shipped to the user and distributed to their eventual point of use, such as to washing machines ("washers").

[0003] Typically, automated chemical distribution systems distribute liquid chemicals, as it is relatively easy to distribute liquids, as compared to non-liquids like powder, to their eventual point of use. However, transporting liquid chemicals to the end user presents a number of drawbacks. For example, liquid chemicals occupy a large volume, are heavy, and, therefore, are expensive to ship and transport to the end user. Furthermore, certain chemicals are more easily manufactured and stored as a non-liquid form, *e.g.*, a powder, and, therefore, manufacturing and shipping these chemicals in a liquid form increases the complexity and cost, and decreases the usability, of such liquid chemicals.

[0004] On the other hand, non-liquid chemicals, *e.g.*, powders, are easier to store and ship. Non-liquid chemicals are also generally less complex and expensive to manufacture. However, a non-liquid chemical is not easy to automatically distribute to its eventual point of use. However, those few automated chemical distribution systems that distribute powdered chemicals require separate automated chemical distribution systems for liquid chemical distribution. In other words, existing automated chemical distribution systems that distribute liquid chemicals to their point of use are not compatible with powdered chemicals. Such duplication of automated chemical systems substantially increases the overall complexity and cost of automatically distributing chemicals to their points of use.

[0005] US 3,570,717 discloses a dispensing system for an aqueous dispersion of solid detergent material, wherein the dispensing system comprises a mixing tank configured to receive a powdered chemical and water to form a detergent-in-water dispersion, the mixing tank comprising a liquid level sensor, the dispensing system further comprising a storage vessel to receive the dispersion from the mixing tank.

[0006] WO 2005/068060 A1 discloses a method and an apparatus for producing a detergent stock solution for use in industrial washing machines. A detergent paste product from a paste stock container is dispersed in water for storage in a preparation tank.

[0007] In light of the above, it would be highly desirable to provide a single chemical distribution system that can distribute accurately dosages of both liquid and powdered chemicals.

SUMMARY

[0008] According to the invention, a powdered and liquid chemical distribution system is provided as defined in independent claim 1. Further, according to the invention, a method for distributing powdered and liquid chemicals to a device is provided as defined in independent claim 15. Preferred embodiments of the invention are the subject-matter of the dependent claims. The powdered and liquid chemical distribution system of the present invention includes first, second and third chambers and a manifold. The first chamber is defined by at least one first chamber wall, and includes first and second ends and a port. The first chamber first end is configured to receive water and one or more powdered chemicals into the first chamber, while the first chamber second end is opposite the first chamber first end. The port is formed in the at least one first chamber wall, and is configured to be coupled to a sensor. The second chamber is defined by at least one second chamber wall and also includes first and second ends. The second chamber first end is fluidly coupled to the first chamber second end, while the second chamber second end is opposite the second chamber first end. One or more liquid chemical inlets are formed in the at least one second chamber wall, where each of the liquid chemical inlets is configured to be coupled to a different liquid chemical source. The manifold includes a manifold inlet fluidly coupled to the second chamber second end, and one or more manifold outlets each configured to be coupled to a different device.

[0009] Further, according to the present invention there is provided a method for distributing powdered and liquid chemicals using such a chemical distribution system. Water is introduced into an upper end of the first chamber. A liquid chemical is then injected into the second chamber that is fluidly coupled to a lower end of the first chamber until a desired volume of the liquid chemical has been introduced. The desired volume of liquid chemical and at least some of the water is pumped to a device (e.g. a washer). Water and a desired dose of a powdered chemical is then inserted into the upper end of the first chamber, and thereafter transported to the device.

[0010] In many of these various systems and methods flow of liquid is achieved with gravity feed only, where each subsequent lower chamber or tubing has a smaller size or diameter than the chamber above it. Not only does this keep liquid chemicals, powdered chemicals, and/or other chemicals from sticking to the walls of the system (which can damage the system or cause harmful chemical reactions within the system), the downsizing of chambers, and or tubing, produces a higher velocity at the exit point to help clean out or flush the system of

chemicals. Also, the system is continually flushed with water before, during and after the liquid or powdered chemicals are introduced into the system. This also helps to keep the unit clean and free of harmful residue.

[0011] Accordingly, the above described systems and methods provide a single chemical distribution system and method, whereby accurate dosages of both liquid and powdered chemicals can be distributed along a single line to each of multiple washers.

BRIEF DESCRIPTION OF THE DRAWINGS

[0012] For a better understanding of the nature and objects of the invention, reference should be made to the following detailed description taken in conjunction with the accompanying drawings, in which:

Figure 1 is a block diagram of a powdered and liquid chemical distribution system, according to an embodiment of the invention;

Figure 2 is a partial cross-sectional view of the chemical distribution hub of the chemical distribution system shown in Figure 1;

Figure 3 is a partial cross-sectional view of another chemical distribution hub, according to another example which does not form part of the invention;

Figure 4 is a perspective view of the chambers component of a chemical distribution hub, according to another embodiment of the invention;

Figure 5 is a top view looking into the third chamber of Figure 4; and

Figure 6 is a perspective view of additional components of the hub shown in Figure 4.

[0013] Like reference numerals refer to the same or similar components throughout the several views of the drawings.

DETAILED DESCRIPTION OF THE EMBODIMENTS

[0014] The following describes various embodiments of chemical distribution systems and methods. These systems are particularly well suited for on premise laundry (OPL) and machine ware wash (MWW) applications. However, it should be appreciated that the systems and methods described herein may be used for any suitable chemical distribution applications.

[0015] Figure 1 is a block diagram of a powdered and liquid chemical distribution system 100. The system 100 includes a chemical distribution hub 104 (sometimes referred to as a transport

module) that dispenses and/or distributes water and one or more chemicals to devices, such as washers 102(a) and 102(b), along tubes or lines 116. In some embodiments, only a single tube or line is run to each device, unlike current systems which typically require more than one line to each device, as will be explained in further detail below.

[0016] Water is supplied from one or more water sources 110, such as a municipal or city water supply. One or more powdered chemicals may be provided by one or more powdered chemical sources 106 that are coupled to the hub 104 via one or more tubes or lines 112. In some embodiments, the water from the water source 110 is also provided to the hub 104 along the same lines 112 that supply the powdered chemical(s). Also in some embodiments, the powdered chemical sources receive disposable powdered chemical refill containers 118. A suitable powdered chemical source and/or container is disclosed in Applicant's US Patent Publication No. US 2005/0247742A1 entitled "Metering and Dispensing Closure".

[0017] In addition, one or more liquid chemicals may be provided by one or more liquid chemical sources 108 that are coupled to the hub 104 via one or more tubes or lines 114. In some embodiments, the powdered chemical sources receive disposable liquid chemical refill containers 120. In other embodiments, one or more liquid chemicals may be supplied from a tank that is refilled, or the like.

[0018] Figure 2 is a partial cross-sectional view of the chemical distribution hub 104 of the chemical distribution system 100 shown in Figure 1. In some embodiments, the hub 104 includes three chambers. It should however be appreciated that more or less chambers may be used. The three chambers include a measuring chamber ("first chamber") 208, a chemical chamber ("second chamber") 210, and a transport chamber ("third chamber") 206. In some embodiments, the three chambers are aligned with one another in use so that the third chamber 206 is disposed vertically above the first chamber 208, and the first chamber 208 is disposed vertically above the second chamber 210, i.e., aligned along a vertical line that is perpendicular to the horizon. In some embodiments, the three chambers are aligned with one another such that fluid can flow under a gravitational force from the third chamber 206 to the first chamber 208, and from the first chamber 208 to the second chamber 210.

[0019] The first chamber 208 is defined by at least one first chamber wall. In some embodiments the first chamber wall is a circular wall that defines a cylinder having a first diameter D_1 . The volume of the chamber is selected such that any change in fluid level in the chamber is great enough to allow easy sensing of the change in pressure by a sensor, described below, while retaining the water volume low enough to allow rapid flushing at the end of a dose cycle. A suitable range of first diameters and heights of the first chamber are 0.5-2 inches and 4 to 10 inches, respectively. The first chamber 208 has a first chamber first end 242, an opposing first chamber second end 244, and a port 228. The first chamber first end 242 is configured to receive into the first chamber 208: (i) water 202, from a water source 110 (Figure 1), and/or (ii) one or more powdered chemicals 204, from one or more powdered chemical sources 106 (figure 1). The port 228 is formed in the first chamber wall. In some embodiments, the port 228 is situated near the first chamber second end 244. Also in some

embodiments, the port has a diameter that is significantly larger than the pressure sensor input tube to create a trapped air pocket between the chamber and the pressure sensor input tube. Also in some embodiments, the diameter of the port 228 is chosen so that water is not drawn or held in the port by a capillary action. In some embodiments, the height of the first chamber that is used for calibration is in the range of 2 to 6 inches above the port 228.

[0020] The port 228 allows fluid communication into the first chamber 208. The port 228 is configured to be coupled to a sensor 236. In some embodiments, the sensor 236 is a pressure sensor, such as an absolute pressure sensor, that measures the head of fluid in the first chamber 208 above the port 228. In some embodiments, the sensor 236 is disposed within a controller 214. The controller 214 is configured to calibrate the chemical distribution system, control the flow of water and chemicals into the hub 104, and control the flow of water and chemicals to the various devices 102 (Figure 1), as described in further detail below.

[0021] The second chamber 210 is defined by at least one second chamber wall. In some embodiments the second chamber wall is a circular wall that defines a cylinder having a second diameter D_2 . In some embodiments, the first diameter D_1 , i.e., the diameter of the first chamber is larger than the second diameter D_2 , i.e., the diameter of the second chamber. The second diameter is chosen to be large enough to allow liquid chemicals to be injected into the second chamber, but small enough to facilitate high velocities of water to flush any liquid chemical residue from the second chamber. A suitable range second diameters and heights of the second chamber are 0.25 to 1.75 inches and 5 to 11 inches, respectively. The second chamber 210 has a second chamber first end 246, an opposing second chamber second end 248, and one or more chemical inlets 230 in the at least one second chamber wall. The second chamber first end 246 is configured to be coupled to the first chamber second end 244. Each of the one or more chemical inlets 246 allows fluid communication into the second chamber 210. In some embodiments, each of the chemical inlets is configured to be coupled to a different liquid chemical source 108 (Figure 1). Where multiple chemical inlets are provided, but fewer chemical sources are provided, the additional inlets may be capped. Each chemical inlet 230 coupled to a chemical source, is coupled to a tube or line 114, such as a flexible plastic tube, that is coupled to the chemical source. In some embodiments, each of these chemical inlets 230 is coupled to a respective chemical source via a chemical pump 216, as shown. For example, a flexible plastic tube transporting a liquid chemical may be inserted through a positive displacement pump, such as a peristaltic pump. In some embodiments, each chemical pump 216 is located within a respective liquid chemical source 108.

[0022] The manifold 212 has a manifold inlet 250 fluidly coupled to the second chamber second end 248. In some embodiments, the manifold may be coupled to the second chamber second end via a tube or line (see Figure 6). The manifold also includes one or more manifold outlets 232 each configured to be coupled to a different device 102 (Figure 1). Where multiple manifold outlets 232 are provided, but fewer devices are provided, the additional outlets may be capped. Each manifold outlet 232 coupled to a device, is coupled to a tube or line 116, such as a flexible plastic tube, that is coupled to the chemical source. In some embodiments, each of these manifold outlets 232 is coupled to a respective device via a transport pump 218, as

shown. For example, a flexible plastic tube transporting water and a chemical to a device may be inserted through a positive displacement pump, such as a peristaltic pump.

[0023] The third chamber 206 is defined by at least one third chamber wall. In some embodiments the third chamber wall is a circular wall that defines a cylinder having a third diameter D_3 . Also in some embodiments, the third diameter D_3 , i.e., the diameter of the third chamber is larger than the first diameter D_1 , i.e., the diameter of the first chamber. The third chamber 206 has a larger diameter to facilitate larger volumes of, particularly of water, to be transported once calibration has taken place. The larger diameter also provides an overflow volume in case of failure of the sensor 236, i.e., if the sensor fails, the water entering the third chamber can rise without overflowing until the flow of water is automatically stopped by the controller after a predetermined time period. A suitable range of third diameters are 3 to 7 inches. The third chamber 206 includes a third chamber first end 252 and a third chamber second end 254. The third chamber first end 252 is configured to receive water 202 and chemicals 204 into the third chamber 206. For example, water 202 is received from at least one water source 110 (Figure 1) and one or more powdered chemical(s) 204 are received from the powdered chemical source(s) 106 (Figure 1). The third chamber second end 254 is located opposite the third chamber first end 252. The third chamber second end 254 is fluidly coupled to the first chamber first end 242.

[0024] In use, the chemical distribution system may first be initialized to: ensure that the water level is known and ready for feed or distribution, to measure sensor offset, and to compensate for drift of the sensor output. First, the controller 214 may verify communication with the remote chemical sources, valves, pumps, etc. One or more of the transport pump(s) 218 are then run until the sensor 236 measures that the level in the first chamber has stopped dropping, i.e., the fluid in the first chamber has dropped below the port 228. The controller then records the sensor output as zero offset, which is used to adjust all readings during feed or distribution to the devices. If the sensor continues to report that the level is dropping after a predetermined time period, then an error exists and the user is notified.

[0025] Next, the system checks that the transport pump and water supply are operational before starting to pump chemicals. The water supply 110 (Figure 1) is turned on and the system waits for the level to rise above the sensor to a predetermined level. One or more of the transport pumps 218 are then turned on and the controller 214 waits for the level in the first chamber 208 to drop to just above the port 228. At that time, the transport pump is turned off.

[0026] To dispense a liquid chemical, all flow out of the manifold is stopped, e.g., pumps 216 and 218 are turned off. If water is not already present in the first chamber, then water is injected from the water source 110 (Figure 1) into the third chamber 206. The water flows into the first chamber 208 and is filled to a level just above the port 228.

[0027] The chemical(s) to be dispensed (typically a liquid chemical) are introduced into the second chamber 210 via one or more of the chemical inlets 230. This may be accomplished by turning on the chemical pump(s) 216. The entry of the chemical(s) into the second chamber

210 causes the water in the first chamber 208 to rise. The resulting change in water level in the first chamber is detected by the sensor 236, i.e., the sensor detects the change in head (pressure) in the first chamber. As the volume of the first chamber is known, the increase in pressure is used to determine the volume of chemical(s) being injected. When the desired volume has been reached, flow of the chemical(s) into the second chamber 210 is stopped, e.g., the chemical pump(s) 216 are turned off by the controller 214. The chemical(s) and water are then distributed to a desired device 102 (Figure 1). This may be accomplished by, for example, turning on one of the transport pumps 218 for a predetermined amount of time sufficient to pump the chemical(s) and water to a desired device 102 (Figure 1). The water that follows the chemical(s) to the device has the added advantage of flushing the chemical distribution system of the chemical(s).

[0028] Where larger dosages of liquid chemicals are to be dispensed and distributed, the chemical to be dispensed (typically a liquid chemical) is introduced into the second chamber 210 via one or more of the chemical inlets 230. This may be accomplished by turning on the chemical pump 216. The entry of the chemical into the second chamber 210 causes the water in the first chamber 208 to rise. The resulting change in water level in the first chamber is detected by the sensor 236, i.e., the sensor detects the change in head (pressure) in the first chamber. As the volume of the first chamber is known, the increase in pressure is used to determine the volume of chemical being injected. When a predetermined volume has been injected, flow of the chemical into the second chamber 210 is stopped by the controller 214 turning off the chemical pump 216. The controller 214 also measures the time that it takes the chemical pump 216 to inject the predetermined volume. The controller 14 uses the predetermined volume and the measured time to determine the flow rate of the liquid chemical being injected by the chemical pump 216. Using this calculated flow rate, the controller turns on the chemical pump 216, a flow of water, and the transport pump 218 until the larger dosages of liquid chemical has been dispensed and distributed. During this dispensing and distributing phase, the controller maintains the level of water in the third chamber by measuring the pressure and turning on or off the transport pump 218 and/or water flow into the third chamber. The larger volume of the third chamber allows for some variation in water volume in the third chamber as the level is maintained. In this way larger dosages of liquid chemicals may be distributed to a desired device 102 (Figure 1). As described above, the water that follows the chemical(s) to the device has the added advantage of flushing the chemical distribution system of the chemical(s).

[0029] To dispense a powdered chemical, a known dose of powdered chemical 204 and water 202 is introduced into top of the third chamber 206. The water and powdered chemical mix is then distributed to a desired device 102 (Figure 1). An advantage of this system is that the powdered chemicals may be distributed to each device along the same single line as the liquid chemicals. This may be accomplished by, for example, turning on one of the transport pumps 218. More water may then be injected into the third chamber 206 to flush the chemical distribution system of the chemical.

[0030] The above described chemical distribution system and method allows the controller 214

to accurately dispense a desired dose of powdered and/or liquid chemicals to a ware wash or laundry washer along a single tube or line 116.

[0031] Figure 3 is a partial cross-sectional view of another chemical distribution hub 300. Chemical distribution hub 300 is configured to receive water 302, one or more powdered chemicals 304, and one or more liquid chemicals 305. Unlike the hub 104 shown in Figure 2, the hub 300 includes only a single chamber 307. The chamber 307 is defined by at least one chamber wall. In some embodiments the chamber wall is a circular wall that defines a cylinder having a predetermined diameter D. The volume of the chamber is selected such that any change in fluid level in the chamber is great enough to allow easy sensing of the change in pressure by a sensor, while retaining the water volume low enough to allow rapid flushing at the end of a dose cycle. A port 308 is formed in the chamber wall that allows fluid communication into the chamber. The port 308 is coupled to a sensor. In some embodiments, the sensor is a pressure sensor, such as an absolute pressure sensor, that measures the head of fluid above the port 308. In some embodiments, the sensor 236 (Figure 2) is disposed within a controller (not shown), which calibrates the chemical distribution system, controls the flow of water and chemicals into the hub, and controls the flow of water and chemicals to the various devices 102 (Figure 1).

[0032] The chamber 307 also includes one or more liquid chemical inlets 310 in the chamber wall below the port 308, and one or more outlets 312 that are each configured to be coupled to a different device 102 (Figure 1). In use, liquid chemicals 306 are introduced into the chamber through the chemical inlets 310, and powdered chemicals 304 are introduced into the chamber through the top of the chamber 322. The water and chemicals are distributed to the devices through the outlets 312. Calibration, dosage, measurement, distribution and other control occurs in a similar manner to that described above in relation to Figure 2.

[0033] Figure 4 is a perspective view of the chambers component of a chemical distribution hub 400, according to another embodiment of the invention. The hub 400 includes many of the same components as described above in relation to Figure 2. For example, hub 400 includes a first chamber 404 that is similar to the first chamber 208 (Figure 2), a second chamber 408 that is similar to the second chamber 210 (Figure 2), a third chamber 402 that is similar to the third chamber 206 (Figure 2), three chemical inlets 410 that are similar to the chemical inlets 230 (Figure 2), and a port 406 coupled to a sensor that is similar to the port 228 (Figure 2). In some embodiments, the port 406 is disposed at an acute angle to the first chamber wall so that the port drains as the water level drops during flushing of water and chemical(s) to the devices 102 (Figure 1). Although each of the first, second, and third chambers are shown in Figure 2 as having stepped boundaries, in this embodiment the boundaries between chambers are graduated, e.g., the diameters of the chambers change gradually so that fluid easily drains from the chambers and there is no powder build-up. The hub 400 also includes an outlet port 412 that is coupled to a manifold via tube or line, as shown and described in relation to Figure 6. A suitable range of diameters for the outlet port 412 is 1/8 to 1 inches.

[0034] Figure 5 is a top view looking into the third chamber 402 of Figure 4. To prevent false

readings of the sensor that may occur when water or chemicals entering the first chamber 402 pass directly over the port 406, a baffle 502 is positioned in the first chamber 402 above the port 406. The baffle 502 may be coupled to the wall of the first chamber. In some embodiments, the baffle 502 is formed in an angled shape to deflect water and chemicals away from the port 406. The baffle 502 may be formed from the same material as the first, second, and third chambers, and in some embodiments may be injection molded together as a single piece together with the first, second, and third chambers, port, and chemical inlets.

[0035] Figure 6 is a perspective view of additional components of the hub 400 shown in Figure 4. This view of the hub 400 includes the chambers shown in Figure 4. The outlet 412 is fluidly coupled to a manifold 604 via a flexible tube or pipe 602. The three outlets from the manifold are in turn fluidly coupled to three separate transport pumps 608 via flexible tubes or lines. In some embodiments, the transport pumps are peristaltic pumps. Each of the flexible tubes or lines exiting the manifold is configured to be fluidly coupled to a separate device, such as a washer. In some embodiments, the chambers, manifold 604, and pumps 608 are coupled to a mounting plate 606 to allow the hub 400 to be wall mounted. The hub 400 may also house the controller 214 (Figure 2). A housing (not shown) may connect to the mounting plate 606 to enclose the above described components.

[0036] While the foregoing description and drawings represent the preferred embodiments of the present invention, it will be understood that various additions, modifications and substitutions may be made therein without departing from the scope of the present invention as defined in the accompanying claims. In particular, it will be clear to those skilled in the art that the present invention may be embodied in other specific forms, structures, arrangements, proportions, and with other elements, materials, and components, without departing from the scope of the invention as defined in the accompanying claims. For example, it should be appreciated that while the above described systems and methods are directed to dispensing and distributing chemicals to washers, such as fabric washers or dishwashers, the above described systems and method may be used equally well to dispense and distribute chemicals to any other suitable devices or applications, such as water conditioners, swimming pools, etc. The presently disclosed embodiments are therefore to be considered in all respects as illustrative and not restrictive, the scope of the invention being indicated by the appended claims, and not limited to the foregoing description.

REFERENCES CITED IN THE DESCRIPTION

This list of references cited by the applicant is for the reader's convenience only. It does not form part of the European patent document. Even though great care has been taken in compiling the references, errors or omissions cannot be excluded and the EPO disclaims all liability in this regard.

Patent documents cited in the description

- US3570717A [0005]
- WO2005068060A1 [0006]
- US20050247742A1 [0016]

Patentkrav

1. Fordelersystem til pulverformede og væskeformede kemikalier, omfattende:

5 - et kemikaliefordelingscenter (104), hvor kemikaliefordelercentret (104) omfatter et første kammer (208), et andet kammer (210), en manifold (212) og en styring (214),

- hvori styringen (214) er konfigureret til at styre strømmen af vand og kemikalier ind i centret (104),

10 - hvori en føler (236) er koblet til styringen (214), hvori det første kammer (208) er defineret af en første kammervæg, der omfatter:

det første kammers første ende (242) konfigureret til at modtage vand i det første kammer, hvor vandet definerer et vandniveau i det første kammer, og det første kammers første ende yderligere er konfigureret til at modtage et pulverformet kemikalie i det første kammer,

15 det første kammers anden ende (244) modsat det første kammers første ende, og

en port (228) i den første kammervæg, hvori porten (228) er koblet til føleren (236),

20 hvori det andet kammer (210) er defineret ved en anden kammervæg, hvilken anden kammervæg omfatter:

det andet kammers første ende (246) flydende koblet til det første kammers anden ende for at modtage vand og et eller flere pulverformede kemikalier fra det første kammer,

25 det andet kammers anden ende (248) modsat det andet kammers første ende, og

et eller flere kemikalievæskeindløb (230) i den anden kammervæg, hvori hvert af kemikalievæskeindløbene er konfigureret til at kobles til en forskellig kemikalievæsk kilde (108) for at modtage et væskeformet kemikalie fra kemikalievæsk kilde (108),

30 og hvori manifolden (212) omfatter:

et manifoldindløb (250) koblet flydende til det andet kammers anden ende, og

et manifoldudløb (232) konfigureret til at kobles til en indretning (102),

35 hvori styringen er konfigureret til at standse strømmen af ethvert fluid ud af manifolden (212) før det andet kammer (210) modtager det væskeformede kemikalie,

hvori det væskeformede kemikalie modtaget i det andet kammer (210) efter standsning af strømmen af fluid ud af manifolden (250) forårsager en stigning af

vandniveauet i det første kammer (208), indtil der er indført et ønsket volumen af det væskeformede kemikalie registreret af føleren (236),
hvor i styringen er konfigureret til at tillade væskeformet kemikalie og vand at strømme fra det andet kammer til manifolden efter at det ønskede volumen af
5 væskeformet kemikalie er blevet indført,
hvor i styringen (214) er konfigureret til at afgive en ønsket dosis af pulverformet kemikalie og væskeformet kemikalie til indretningen (102), og
hvor i det første kammer og det andet kammer er arrangeret i flydende serielt forhold sådan, at det pulverformede kemikalie og vandet strømmer fra det første
10 kammer gennem det andet kammer.

2. Fordelersystem for pulverformede og væskeformede kemikalier ifølge krav 1, yderligere omfattende et tredje kammer (206) defineret af en tredje kammervæg, der omfatter:

- 15 - det tredje kammers første ende (252) konfigureret til at modtage vand fra en vandkilde (110) og det pulverformede kemikalie fra en kemikaliepulverkilde (106) i det tredje kammer, og
- det tredje kammers anden ende (254) modsat det tredje kammers første ende, hvor i det tredje kammers anden ende er koblet flydende til det første kammers
20 første ende, sådan at det pulverformede kemikalie og vand strømmer ind i det første kammer (208).

3. Fordelersystem for pulverformede og væskeformede kemikalier ifølge krav 2, hvor i det tredje kammer har et større volumen end det første kammer, og det
25 første kammer har et større volumen end det andet kammer.

4. Fordelersystem for pulverformede og væskeformede kemikalier ifølge krav 2, hvor i systemet er konfigureret til at tillade fluid at strømme under tyngdekraftens virkning fra det tredje kammers første ende mod det andet kammers anden ende.
30

5. Fordelersystem for pulverformede og væskeformede kemikalier ifølge krav 1, hvor i det første kammer har et større volumen end det andet kammer.

6. Fordelersystem for pulverformede og væskeformede kemikalier ifølge krav 1, hvor i systemet er indrettet til under brug at tillade fluid at strømme under tyngdekraftens virkning fra det første kammers første ende mod det andet kammers anden ende.
35

7. Fordelersystem for pulverformede og væskeformede kemikalier ifølge krav 1, hvori føleren er en trykføler anvendt til at bestemme fluidets højde over porten i det første kammer.
- 5 8. Fordelersystem for pulverformede og væskeformede kemikalier ifølge krav 1, hvori hvert af kemikalievæskeindløbene er konfigureret til at være koblet flydende til en forskellig kemikalievæsketilførelse via en forskellig pumpe.
- 10 9. Fordelersystem for pulverformede og væskeformede kemikalier ifølge krav 1, hvori manifoldudløbet omfatter mindst to manifoldudløb, der hver er koblet til en vasker via en forskellig vaskerpumpe.
10. Fordelersystem for pulverformede og væskeformede kemikalier ifølge krav 2, yderligere omfattende:
- 15 - et væskeudleveringsapparat konfigureret til at levere det væskeformede kemikalie ind i det andet kammer, og
- et kemikaliepulverudleveringsapparat konfigureret til at levere det pulverformede kemikalie ind i det tredje kammer.
- 20 11. Fordelersystem for pulverformede og væskeformede kemikalier ifølge krav 2, hvori systemet er konfigureret til at tillade fluid at strømme under tyngdekraftens virkning fra det tredje kammer til manifolden.
- 25 12. Fordelersystem for pulverformede og væskeformede kemikalier ifølge krav 2, hvori hvert af kemikalievæskeindløbene er konfigureret til at være koblet flydende til en forskellig kemikalievæsketilførelse via en forskellig kemikaliepumpe, og hvori det tredje kammers første ende er konfigureret til at modtage vand fra vandkilden og det pulverformede kemikalie fra kemikaliepulverkilden, og hvori manifoldudløbet omfatter flere manifoldudløb, der hver er koblet til en vasker via en vaskerpumpe, hvori systemet yderligere omfatter et styresystem, som elektrisk er koblet til føleren, pumperne, vandkilden og kemikaliepulverkilden for at styre fordelingen af kemikalievæsken og kemikaliepulveret til hver vasker.
- 30 13. Fordelersystem for pulverformede og væskeformede kemikalier ifølge krav 1 eller 2, hvori systemet omfatter et transportmodul konfigureret til automatisk at fordele både det pulverformede kemikalie og det væskeformede kemikalie til indretningen i en enkelt ledning (116).
- 35

14. Fordelersystem for pulverformede og væskeformede kemikalier ifølge krav 13, hvori systemet er konfigureret til automatisk at fordele det pulverformede kemikalie og det væskeformede kemikalie til forskellige indretninger i forskellige enkeltledninger.

5

15. Fremgangsmåde til fordeling af pulverformede og væskeformede kemikalier til en indretning under anvendelse af kemikaliefordelersystemet ifølge ethvert foregående krav, hvilket kemikaliefordelersystem omfatter et første og et andet kammer, omfattende:

- 10 - indføring af vand i en øvre ende af det første kammer, hvor vandet definerer et vandniveau i det første kammer,
- indsprøjtning af et væskeformet kemikalie i det andet kammer, som er koblet flydende til en nedre ende af det første kammer, hvor det væskeformede kemikalie modtaget i det andet kammer forårsager en stigning i vandniveauet i det første
- 15 kammer registreret af en føler koblet til en styring, indtil et ønsket volumen af det væskeformede kemikalie er blevet indført,
- pumpning af det ønskede volumen af det væskeformede kemikalie og mindst noget af vandet til indretningen,
- indføring af vand og en ønsket dosis af et pulverformet kemikalie til den øvre
- 20 ende af det første kammer,
- transport af det pulverformede kemikalie og mindst noget af vandet til indretningen.

25

16. Fremgangsmåde ifølge krav 15, hvori det væskeformede kemikalie og vandet med det pulverformede kemikalie transporteres til indretningen under brug af et enkelt rør eller ledning.

DRAWINGS

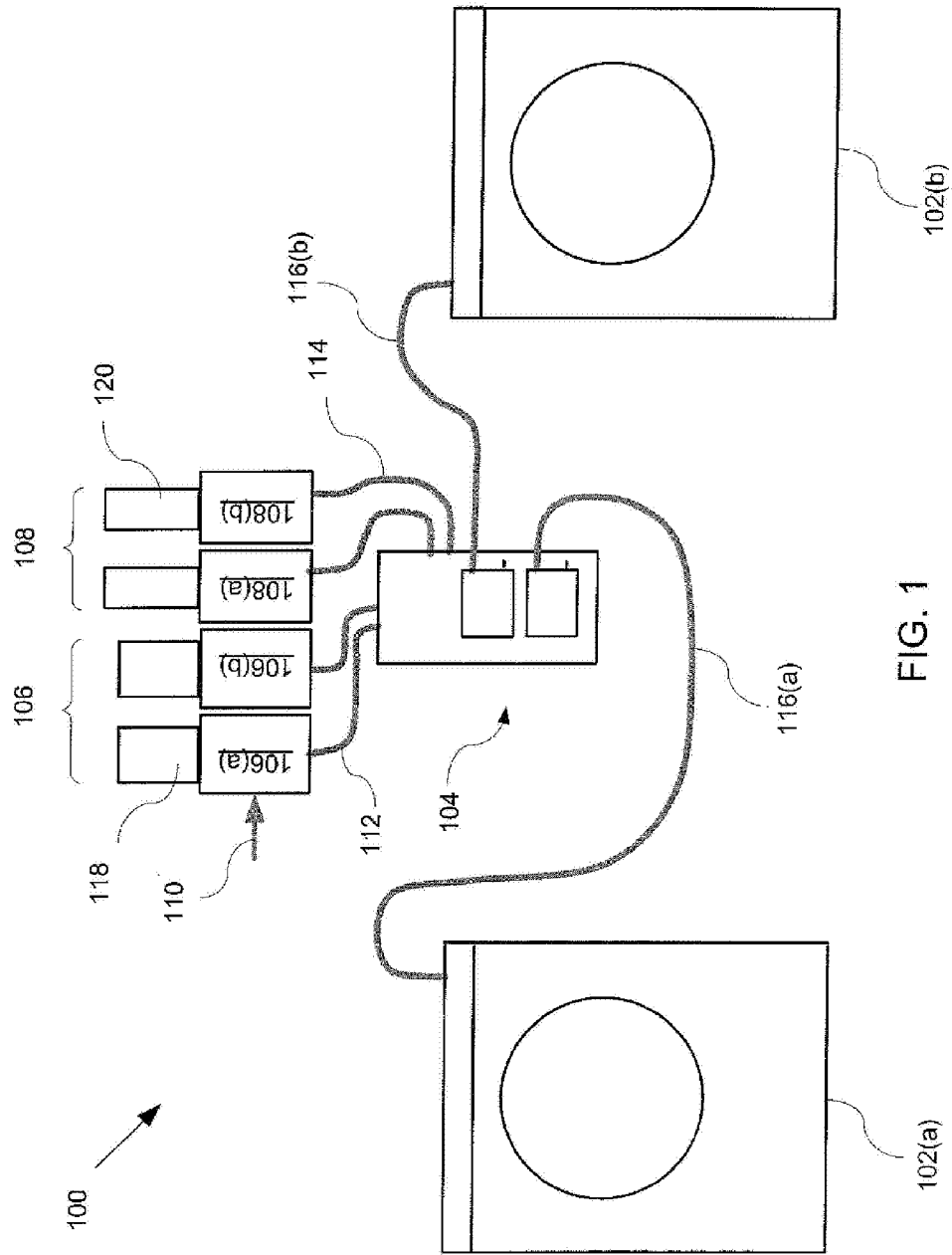

FIG. 1

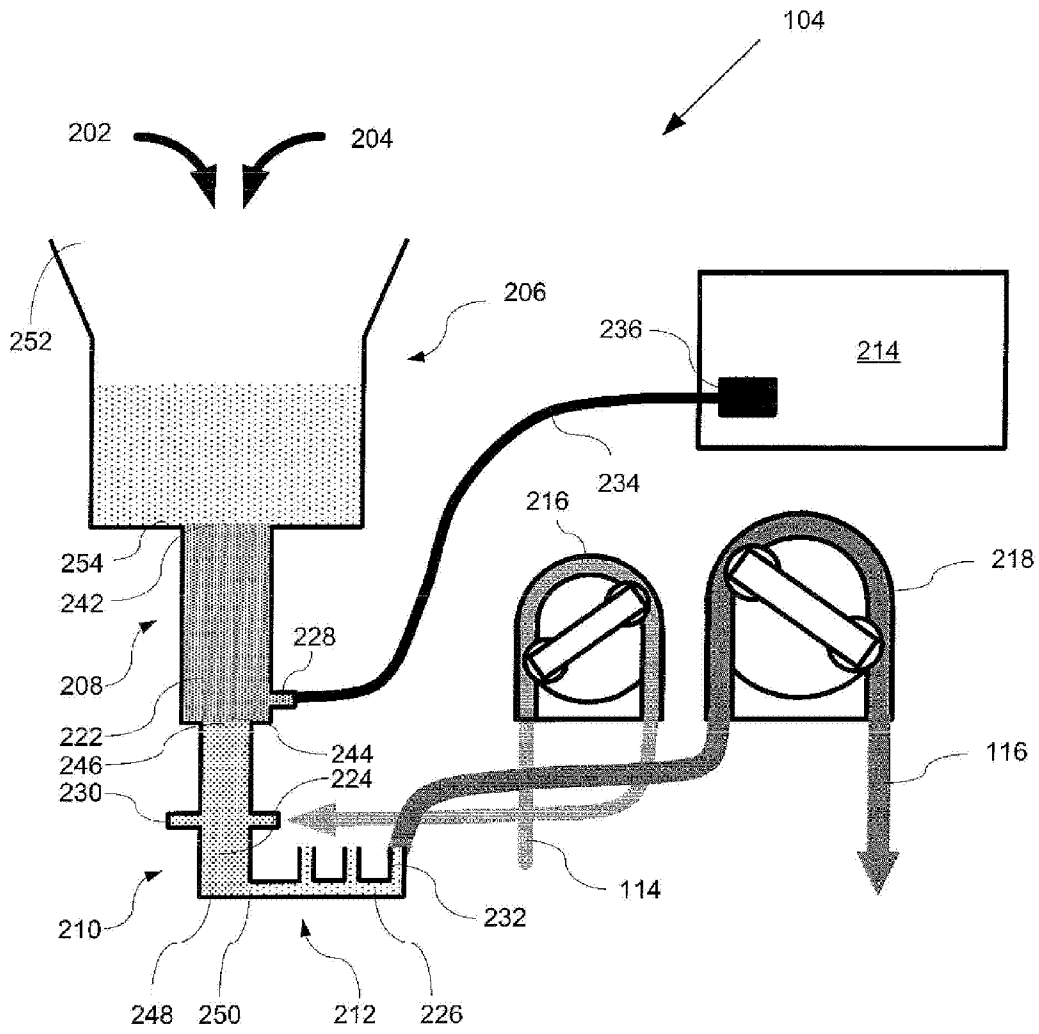

FIG. 2

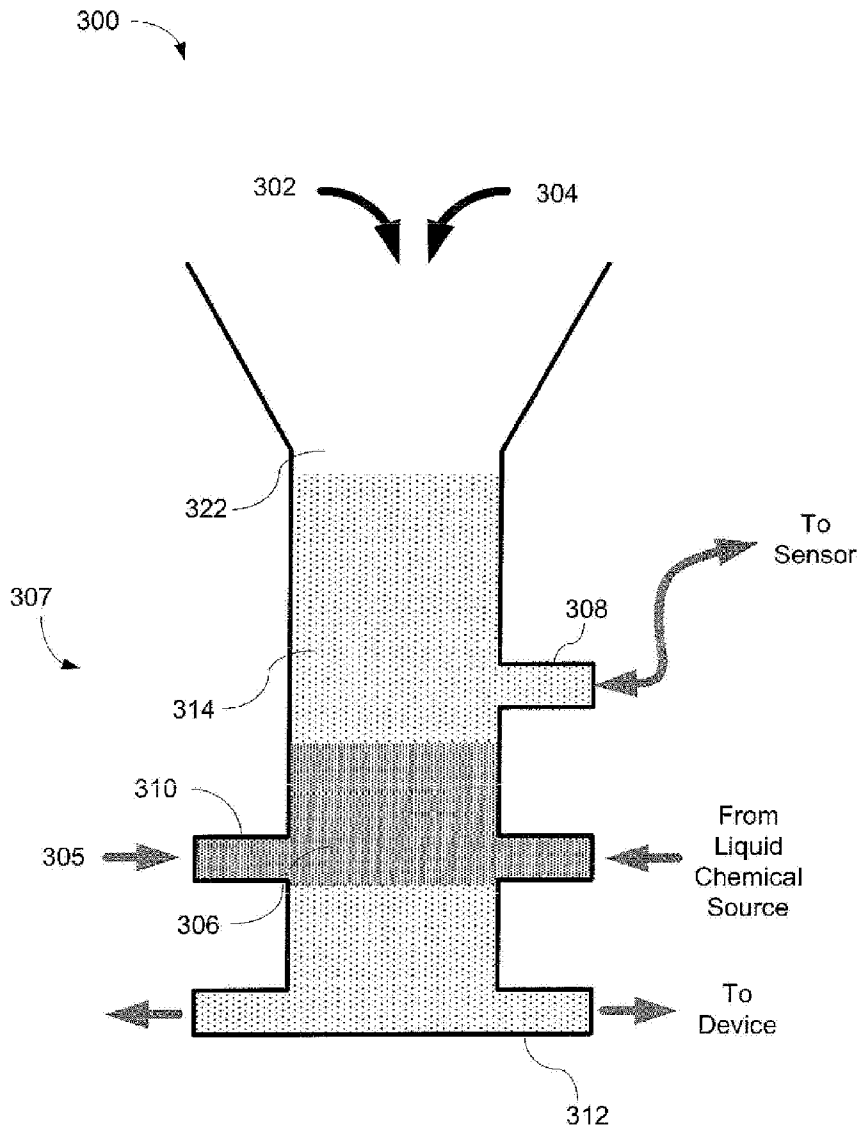

FIG. 3

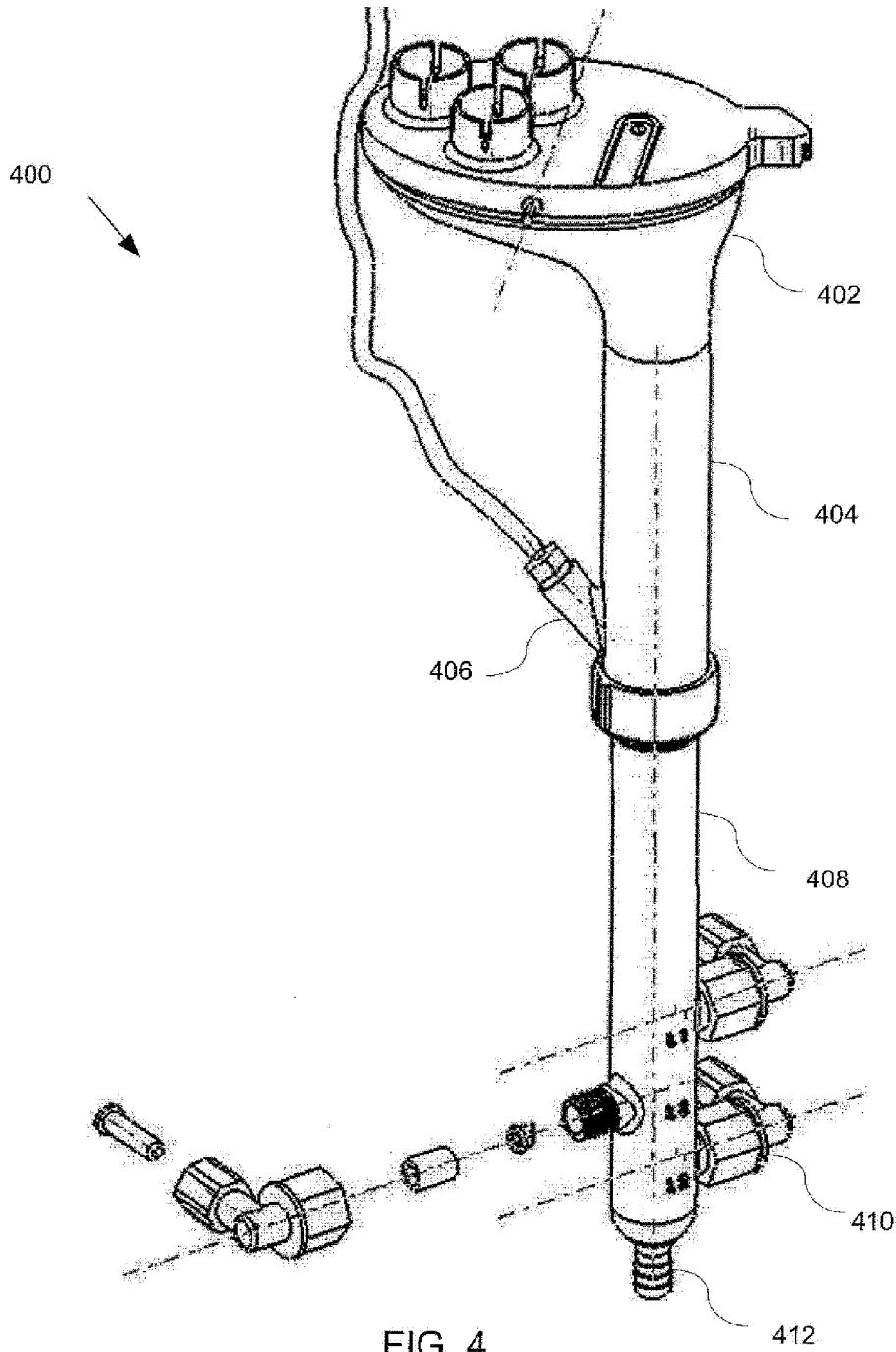

FIG. 4

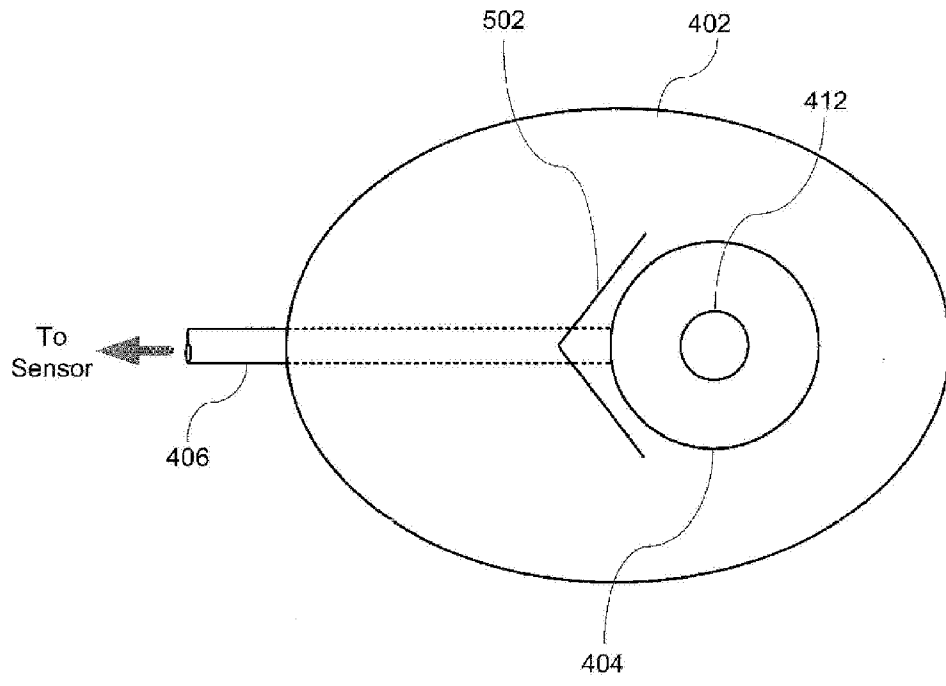

FIG. 5

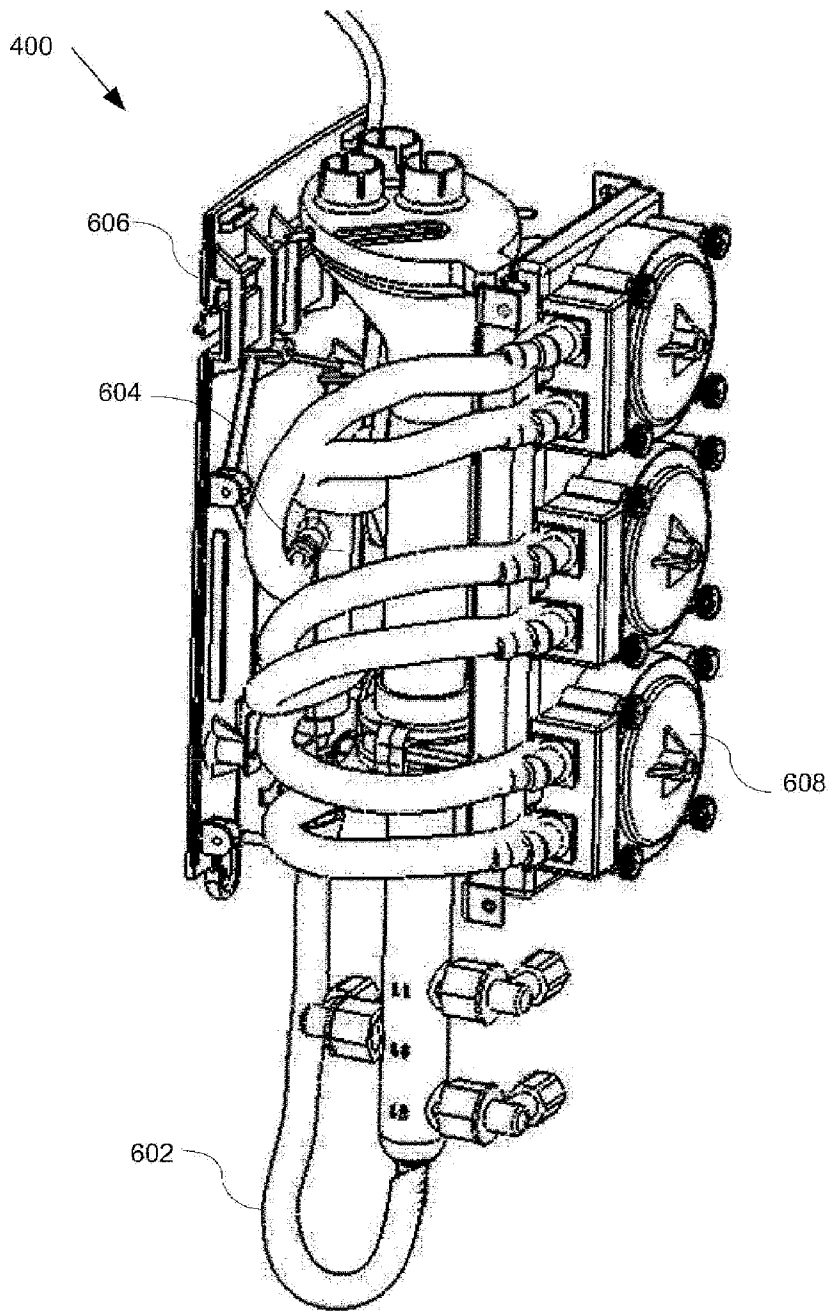

FIG. 6