

Oct. 9, 1934.

E. C. VROOMAN

1,976,378

AVIATION MARKER

Filed Oct. 7, 1929

2 Sheets-Sheet 1

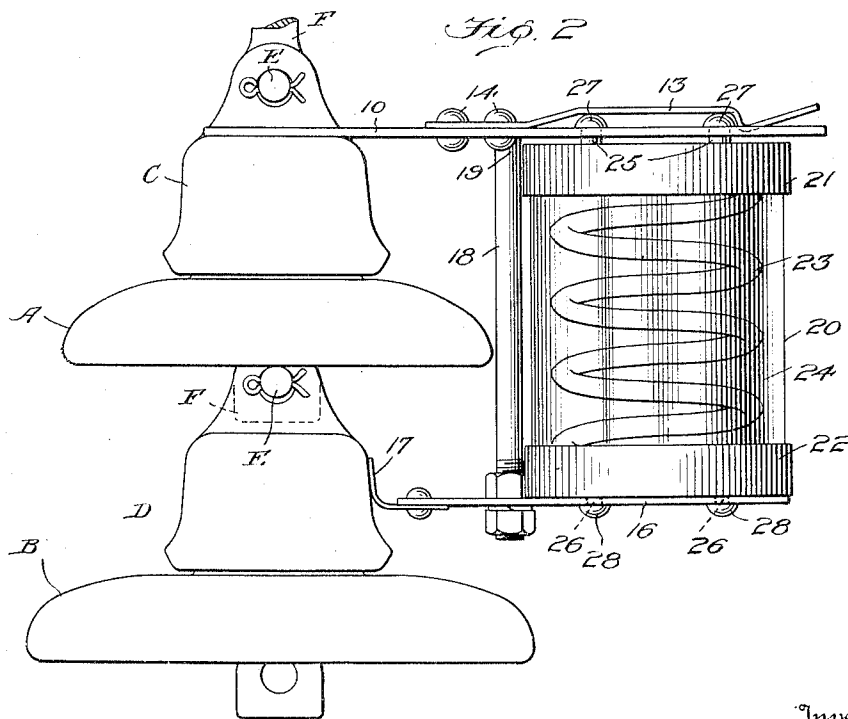
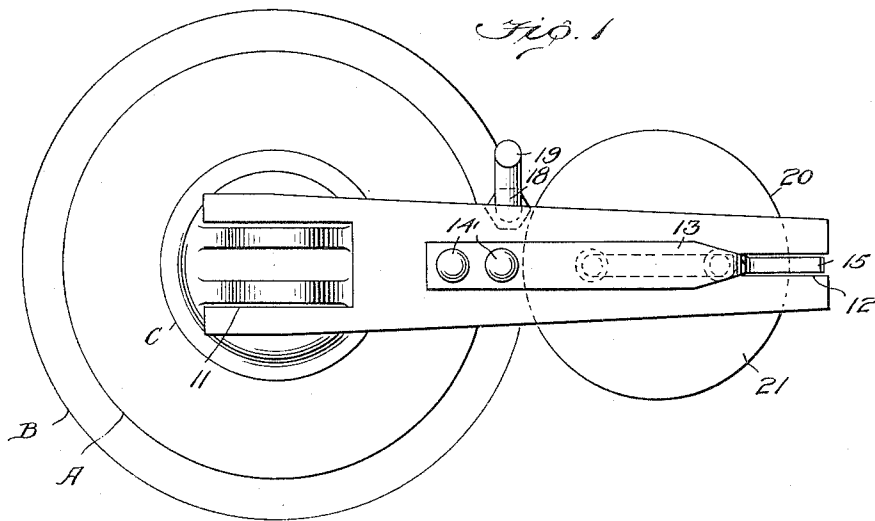

Inventor

Edward C. Vrooman

By

James F. Applelin
Attorney

UNITED STATES PATENT OFFICE

1,976,378

AVIATION MARKER

Edward C. Vrooman, Schenectady, N. Y., assignor
to Locke Insulator Corporation, Baltimore, Md.,
a corporation of Maryland

Application October 7, 1929, Serial No. 398,007

4 Claims. (Cl. 177-352)

The invention relates to warning signals or indicators and has for its object the provision of a device adapted to be used in association and conjunction with high tension transmission lines for the purpose of warning aviators of their proximity to such so that they may govern themselves accordingly and avoid colliding with the lines.

It is known that there are well established air routes which are ordinarily followed by the pilots of mail planes, etc. and that it is a common practice to provide flood lights and various types of beacons for their guidance at night. However, the country is traversed by a network of high tension transmission lines which, if struck against by an airplane will cause destruction thereof with probable death of the pilot. Moreover collisions with high tension lines generally cause interruptions to service. In the daytime such lines are of course easily visible, but at night especially when foggy conditions prevail, these lines are not visible and if a pilot loses his bearings and flies too low, either by inadvertence or when making a forced landing, there is considerable risk that he may encounter and strike against the lines, obviously with serious results.

It is with the above facts in view that I have devised the present invention which has for an important object the provision of a warning signal or indicator comprising a neon tube which has the power of emitting light of a peculiar character capable of penetrating fog, the intention being to provide a plurality of such devices along a transmission line at the supporting towers therefor so that by observing two or more of such lights the pilot will be apprised not only of the presence of a high tension line but also of the direction in which it extends.

Another important object of the invention is to provide a warning device of this character which is so mounted and related to the insulators which support the transmission line as to be energized either by the normal leakage current over the insulator or insulators or by capacitance current without it being necessary to provide any definite or special connection which will intentionally drain current from the line.

Another object of the invention is to provide a neon tube mounting adapted to be engaged with and carried by the metal parts of adjacent insulators in a string, with or without the employment of supplemental or additional units.

Still another object is to provide a mounting in which there is provided a gap permitting discharge of a sudden surge or impulse in the line, such as might be caused by lightning, thereby

protecting the neon tube against damage on account of passage of excessive current there-through.

A still further object is to provide a tube mounting which may be placed upon the insulator or insulators in the field in a simple manner, it being consequently easily possible to effect installation on already existing equipment.

The invention has for another object a mounting which will permit ready removal and displacement of a neon lamp which has become broken or otherwise unfit for continued use.

An additional object is to provide an arrangement or structure of this character which will be simple and inexpensive to make, easy to install, positive and automatic in action, efficient and durable in service, and a general improvement in the art.

To the attainment of the foregoing and other objects and advantages, the invention preferably consists in the details of construction and the arrangement and combination of parts to be hereinafter more fully described and claimed, and illustrated in the accompanying drawings in which:

Figure 1 is a top plan view showing one form of the device applied to a string of suspension insulators,

Figure 2 is a side elevation thereof,

Figure 3 is a side elevation, with parts broken away and in section, illustrating a modification,

Figure 4 is a detail cross sectional view taken on the line 4-4 of Figure 3.

Referring more particularly to the drawings and especially Figures 1 and 2, the letters A and B designate a pair of adjacent insulator units forming part of a string employed for suspending a conductor from a tower or other support. As is well known, such insulator units are provided with metal caps here represented at C and D, the successive units being connected as by bolts E which pass through the upper portions of the caps and through pins F depending from the units. Quite naturally it makes no difference whether the caps of the clevis, ball and socket or other type as the invention to be described is equally applicable to all varieties.

In carrying out one form of the invention I provide a neon lamp mounting which may comprise an elongated metal strip or plate having one end forked at 11 so as to straddle the clevis at the top of the cap C and welded, brazed or soldered to the cap. The free end portion of this strip is preferably slotted at 12 and pro-

vided with a spring clip 13 overlying the slot, the clip being held in place by any suitable means such as the rivets 14, and having an upturned free end 15 constituting a finger hold. The device further includes a bottom member 16 formed as an elongated strip and which may likewise be longitudinally slotted. The member 16 may of course be secured to the cap D but it is preferable that it be equipped at its end simply with a spring element 17 bearing snugly against the cap D while at the same time not interfering with the necessary freedom of movement of the successive insulator units. Suitably secured to the bottom member 16 is an upstanding post or terminal 18 which is laterally offset at some point so that its upper end 19 will be spaced away from the upper member 10 to provide a spark gap across which current may jump in the event of a heavy surge along the line. Instead of having this member offset it is obvious that it might be in line with the members 16 and 10 and terminating below the latter, this detail being immaterial.

The lamp itself is designated as a whole by the numeral 20 and preferably comprises upper and lower metallic ferrules 21 and 22 between which is located and within which are electrically connected the ends of a neon tube 23 of ordinary construction but preferably helical in form so as to possess considerable inductance. A glass or other transparent guard 24 surrounds the tube and is confined between the ferrules 21 and 22, its purpose being to protect the tube during handling and to a certain extent while in service. The ferrules are represented as having stems 25 and 26 with upset heads 27 and 28, the stems 26 being engageable within the slot in the lower member 16 and the stems 25 being engageable within the slot 12 in the upper member 10, the heads 27 being of course above the member 10 and the heads 28 being below the member 16. These stems and heads will prevent lateral displacement of the lamp when in place and displacement longitudinally of the members 10 and 16 is prevented by engagement of the clip 13 over the outermost head 27 as clearly illustrated in Figure 2. In these figures the stems 26 with their heads 28 constitute the only means for retaining the member 16 in place with respect to the lamp as it is clear that there must be no metallic element bridging the members 10 and 16 unless such be carefully insulated.

In Figures 3 and 4 I have illustrated a modification in which there may be provided the same structure for the top mounting and also the same form of lamp. However, the mounting for the lower end is different, there being an angular metallic strip 29 slotted in exactly the same manner as the member 10 and provided with a spring clip 30 corresponding to the clip 13. There is also provided the same type of or an equivalent post or terminal 18 to provide a spark gap. The difference lies in the connection with the insulator, both members 10 and 29 being connected with one insulator alone, the one indicated at A, there being no definite connection with the unit B. In this form the attachment is applied prior to installation of the equipment in the field as the ordinary pin indicated at F in Figures 1 and 2 is replaced by a pin 31 having an outstanding flange 32 which supports the bifurcated end 33 of the metal strip 29, the intention being that this bifurcated end be welded, brazed or soldered onto the flange 32. In order that the cement used for securing the pin 31

within the insulator may be properly introduced, the flange 32 is preferably provided with holes 34 through which the cement may be squirted by means of a gun or the like. Clearly the pin 31 is secured within the insulator prior to the securing of the bifurcated end of the member 29 upon the flange as otherwise some of the holes 34 will be obstructed. However, this is a minor detail of no great consequence as it may easily be varied. The principal point of difference between this form of the invention and the first form is that the device is rigid with respect to one unit.

In the operation of all forms of the invention it will be seen that capacitance current and/or the current which normally leaks over the insulators will pass through the neon tube, causing it to become luminous and to emit light which will of course be visible through the transparent shield or guard. In actual practice it has been discovered that a neon lamp arranged as disclosed will be energized notwithstanding the fact that a lamp of this type usually requires considerably more current than that leaking over the insulators in the string. It has been found that the actual charging current in a string of insulators is usually less than a milli-ampere and that neon tubes of the character disclosed require current of approximately ten milli-amperes. It is consequently safe to assume that current is derived from some source other than mere leakage, there being apparently a resonance effect. In all probability the theory on which the tube operates may be as follows: The larger neon tubes which have been tested out in an equipment of the character disclosed have all been in the form of a coiled cylinder or helix. Such a coiled tube will have a definite measurable reactance. As an insulator unit is a simple elementary condenser, the combination of the insulator and this helical tube in parallel therewith will make a tuned circuit very commonly used, for instance, in radio. There is, however, something necessary to cause an oscillation within this circuit. This generator of radio frequency impulses which is the generator for these oscillations does exist in this combination. The neon tube is but one form of the Fleming valve so commonly used in battery charging except that it operates with a cold cathode. The current will not flow through these tubes until the voltage rises to a certain point well above zero. The current which is already stored in the condenser (the insulator) because of the voltage rise is now allowed to flow through the lamp with a rush. This current flow in a manner well known in electrical engineering transfers the energy previously stored in the condenser to the magnetic field established by the reactance of the coiled conductor, namely the neon tube. This energy causes the current flow to overshoot its mark and to be returned in an oscillatory manner back to the condenser. Furthermore the resultant current is far greater than that which would develop purely from the flow of sixty cycle current. In connection with this theoretical discussion, it should be remembered that we are dealing with alternating current effects, that normally there are one hundred and twenty (120) alternations per second and that these trains occur in every path cycle.

The light from a neon lamp has the peculiar faculty of being able to penetrate fog to a far greater extent than any other light and it is this fact which renders this installation particularly effective for the purpose for which it is intended

as it enables the pilots of aircraft to determine their locations and as it warns them of their proximity to a high tension transmission line. In the event of failure of the neon lamp rendering it unfit for continued use, it is apparent that the lamp may be easily removed and replaced by a fresh one. In the form shown in Figures 1 and 2 it is merely necessary to press upwardly upon the free end 15 of the clip 13 to move the clip out of obstructing relation to the outermost head 27, whereupon the lamp may be slid out of the mounting. In the form shown in Figure 3 it is necessary to spring both clips 13 and 30 outwardly so that the lamp may be slid out.

There is naturally no restriction as to the exact location of the neon lamp in the insulator string as it may be of advantage to utilize different positions in the string for the insulator carrying the neon tube. By varying the position of this insulator the brilliancy of the light could be controlled. On difficult installations it might even be advisable to use the high potential gradient in the immediate neighborhood of the conductor. Also, it might be of advantage to provide, for instance, two additional insulators in series to mount the neon tube as the two insulators in series would decrease the capacity conductance of the path which would short the tube. Such alternative arrangements are not illustrated as it is believed obvious how the installation could readily be effected.

From the foregoing description and a study of the drawings it will be apparent that I have thus provided a simply constructed and inexpensive device for the purpose specified which should be a great safeguard to aviators even under the most adverse conditions. It is thought that the construction, operation and advantages should be readily apparent to one skilled in the art without further explanation.

While I have shown and described the preferred embodiments of the invention, it should be understood that the disclosure is merely an exemplification of the principles involved as the right is re-

served to make all such changes in the details of construction as will widen the field of utility and increase the adaptability of the device provided such changes constitute no departure from the spirit of the invention or the scope of the claims hereunto appended.

Having thus described the invention, I claim:

1. The combination of an insulator with a measurable internal capacitance in series with other similar insulators in a string, said insulator being bridged by a gas filled tube coiled to have sufficient reactance to form an oscillatory circuit.

2. The combination with units of an insulator string, said insulators having definite internal capacity, of a tube of the neon-filled Geissler type shunted across an insulator unit, said tube being coiled to have a measurable reactance sufficient to form an oscillatory circuit whereby the current flow through said gas filled tube is increased.

3. Signal means for an insulator supporting a high tension line and including a dielectric body and metallic portions at opposite sides thereof, the signal means including bracket members mounted on said metallic portions and projecting laterally therefrom, the end portions of the bracket members being slotted, a neon lamp having terminal ferrules equipped with securing elements slidably engaged within the slotted ends of the brackets, and spring clips carried by the brackets and cooperating with said securing elements for holding the lamp in place.

4. Signal means for an insulator unit provided at its top with a cap and at its bottom with a pin, comprising a bracket member secured to the cap, a second bracket member having a slotted end accommodating the pin, said pin having an enlargement thereon bearing against and supporting the second named bracket, and a neon lamp detachably engaged between the brackets and in electrical and mechanical engagement therewith whereby it will be energized by leakage and capacitance currents over the unit.

EDWARD C. VROOMAN.

5 80
 10 85
 15 90
 20 95
 25 100
 30 105
 35 110
 40 115
 45 120
 50 125
 55 130
 60 135
 65 140
 70 145
 75 150