

Feb. 15, 1927.

1,617,480

H. E. FOURCHER

TOY AUTO DEVICE

Filed May 6, 1926

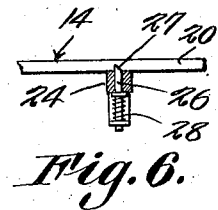
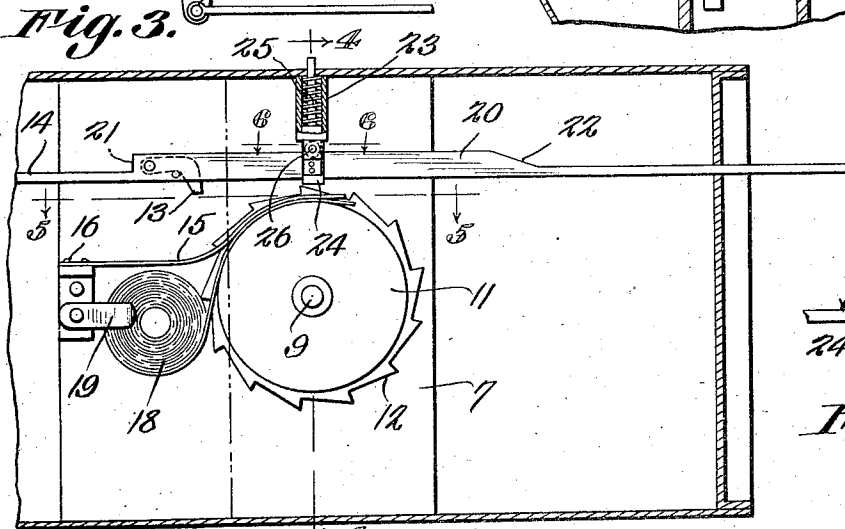
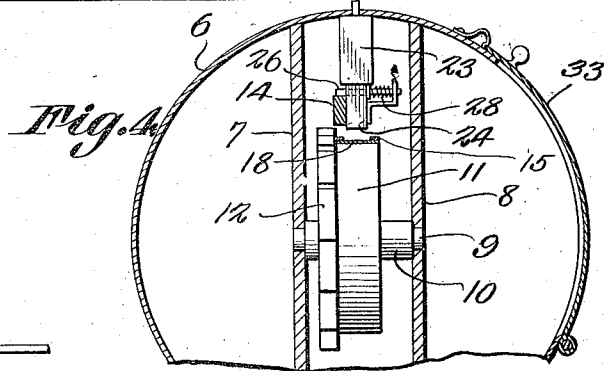
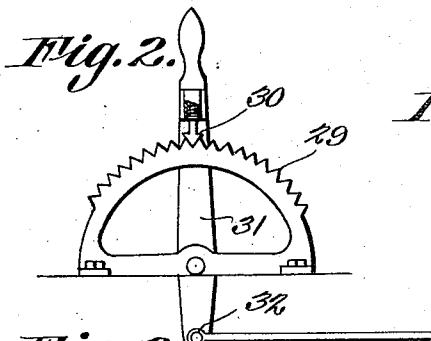
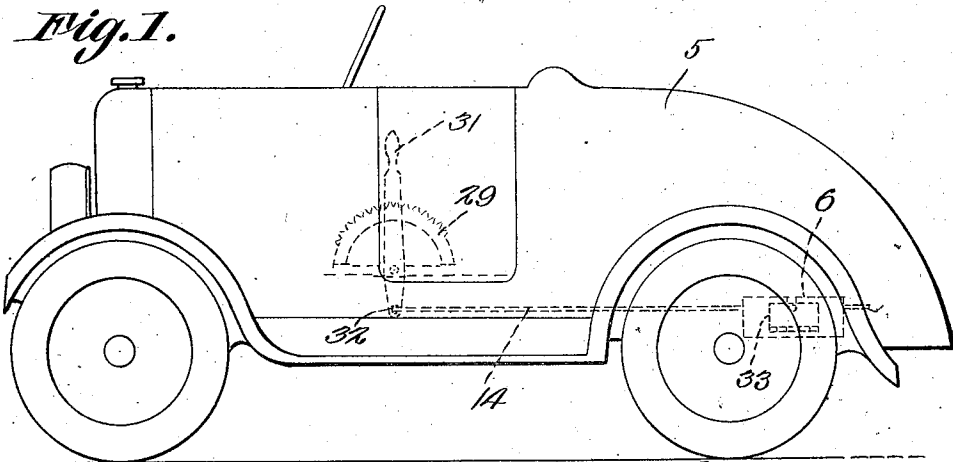

H. E. Fourcher Inventor
C. A. Snow & Co. Attorneys

Fig. 5.

UNITED STATES PATENT OFFICE.

HARRY E. FOURCHER, OF AUGUSTA, GEORGIA.

TOY AUTO DEVICE.

Application filed May 6, 1926. Serial No. 107,256.

This invention relates to toy automobiles of the manually propelled type, the primary object of the invention being to provide means whereby the operator may cause a sound to be produced simulating the back-fire of the usual motor of a motor vehicle.

Another object of the invention is to provide a device of this character which may also be operated to produce a sound simulating the clashing of the gears of the transmission of a motor vehicle, when the gears are being shifted.

With the foregoing and other objects in view which will appear as the description proceeds, the invention resides in the combination and arrangement of parts and in the details of construction hereinafter described and claimed, it being understood that changes in the precise embodiment of the invention herein disclosed, may be made within the scope of what is claimed, without departing from the spirit of the invention.

Referring to the drawing:

Figure 1 is a side elevational view illustrating a toy automobile equipped with a device constructed in accordance with the invention.

Figure 2 is an enlarged detail view of the sound producing device, for producing a sound simulating the clashing of gears.

Figure 3 is an enlarged fragmental sectional view illustrating the cap firing mechanism.

Figure 4 is a sectional view taken on line 4-4 of Figure 3.

Figure 5 is a sectional view taken on line 5-5 of Figure 3.

Figure 6 is a sectional view taken on line 6-6 of Figure 3.

Referring to the drawing in detail, the reference character 5 indicates the body portion of the toy automobile on which the sounding device forming the essence of the invention is mounted.

The sounding device includes a tubular casing 6 mounted adjacent to the rear of the body portion 5, or in a position corresponding with the position of the usual muffler of a motor vehicle.

Mounted within the tubular casing 6 are spaced walls 7 and 8 which are formed with openings to receive the bearings 9 of the shaft on which the hub 10 is mounted, the hub forming a part of the substantially wide cap supporting wheel 11. Adjacent to the wheel 11 is a ratchet wheel 12 adapted to be

engaged by the pawl 13 carried by the actuating arm 14 to rotate the wheel 11.

Associated with the wheel 11 is a spring arm 15 that has one end secured at 16, to the wall 7, the opposite or free end thereof engaging the roll of caps 17 to hold the caps to the wheel 11 to insure the firing of the caps when they are brought under the firing plunger.

The roll of caps is indicated at 18, and as shown, a spring finger 19 is provided and adapted to engage one edge of the roll of caps to hold the roll in position against lateral movement. The free end of the arm 15 is cut away as clearly shown by Figure 5 to provide a space between which the plunger may move, in contacting with the cap to be fired.

As clearly shown by Figure 3 of the drawing, the actuating arm which is indicated at 14 is provided with a widened portion 20 having a substantially straight wall 21 at one end thereof while an inclined wall 22 is formed at the opposite end thereof.

Disposed above the widened portion 20 is a tubular member 23 in which the plunger 24 operates, the plunger being spring pressed so that when the plunger moves to a position adjacent to the straight end portion 21, the plunger will be forced downwardly by the action of the coiled spring 25 to fire the cap lying directly thereunder.

The plunger is held to the limit of its upward movement by means of the laterally movable supporting pin 26 which extends through the plunger and has its free end resting on the widened portion of the arm 14 with the result that as the pin moves over the straight portion, the pin will drop downwardly allowing the plunger to engage the cap as before stated.

The outer edge of the pin 26 is beveled as at 27 so that when the pin drops down over the straight edge of the widened portion 14, the pin will be moved inwardly against the tension of the coiled spring 28 when the arm 13 is moved forwardly, with the result that when the arm 14 is moved to a position to bring the pin 26 opposite the inclined edge 22, the pin will be forced inwardly to engage the upper edge of the arm 14 so that when the arm is moved rearwardly the pin will ride over the inclined surface 22 and again assume a position on the upper edge of the widened portion 20 of the arm 14.

Arranged adjacent to the operator's seat,

is a curved rack 29 which is engaged by the spring pressed pin 30 carried by the pivoted lever 31, which has its lower end pivotally connected to the arm 14 at 32. Thus it will be seen that as the lever 31 is moved over the rack 29, a sound will be produced simulating the clashing of gears of a motor vehicle, but when the lever 31 is moved forwardly to the limit of its forward movement the plunger will be actuated to fire a cap of the roll.

In order that the device may be reloaded a hinged closure 33 is provided, which may be opened to gain access to the interior of the casing.

In view of the foregoing detail description, it is thought that a further detail description as to the operation of the device is unnecessary.

I claim:

1. A toy automobile including a body portion, a casing mounted on the body portion, a sound producing means supported within the casing, a rod for actuating the sound producing means, and a manually controlled lever connected with the rod for operating the rod.

2. A toy automobile including a body portion, a casing mounted on the body portion, a roll of caps supported within the casing, means for firing the caps, and manually controlled means for operating the cap firing means.

3. A toy automobile including a body portion, a casing mounted on the body portion, a roll of caps supported within the body portion, means controlled by the operator of the automobile, for firing a cap within the casing, and means for advancing the cap to its firing position.

4. A toy automobile including a body portion, a casing mounted within the body portion, a cap firing mechanism mounted within the casing, and manually controlled means for operating the cap firing mechanism.

5. A toy automobile including a body portion, a cap mechanism mounted within the body portion, and manually controlled means for operating the cap firing mechanism.

In testimony that I claim the foregoing as my own, I have hereto affixed my signature.

HARRY E. FOURCHER.