

998,094.

Patented July 18, 1911.

2 SHEETS—SHEET 2.

Fig. 3

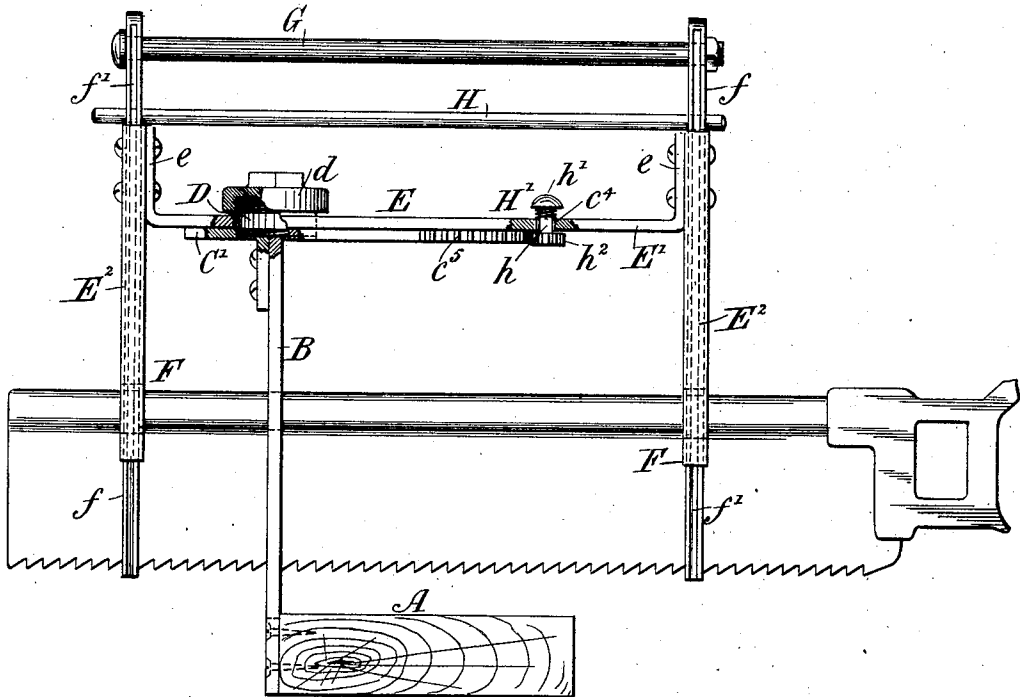
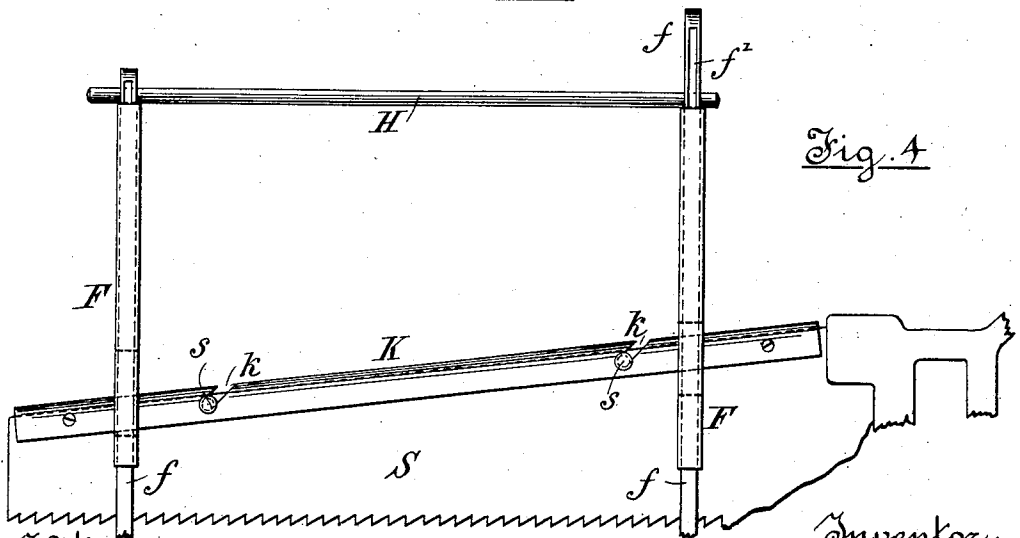

Fig. 4



Witnesses:
 Frank Bennett
 George Taylor

Inventor:
 George R. Hill,
 per Att. A. Kellou
 Attorney.

UNITED STATES PATENT OFFICE.

GEORGE R. HILL, OF PORTLAND, OREGON.

MITER-BOX.

998,094.

Specification of Letters Patent. Patented July 18, 1911.

Application filed June 23, 1910. Serial No. 568,504.

To all whom it may concern:

Be it known that I, GEORGE RICHARD HILL, a citizen of the United States, and resident of the city of Portland, in the county of Multnomah and State of Oregon, have invented a certain new and useful Improvement in Miter-Boxes, of which the following is a specification.

This invention relates to miter-boxes such as are used by carpenters and cabinet makers, and especially to that class which are adjustable in parts within themselves.

My improvements have for their main objects the production of a miter-box which may be conveniently dismembered for transportation and quickly and accurately reassembled by the user;—to provide for greater ease and certainty in the adjustment of parts for making cuts at different angles, and for fixing same at any desired angle for any length of time;—to regulate and fix the depth as well as the angle at which a cut is to be made in any given piece or lot of material;—and to provide means whereby saws of different kinds—with or without rigid backs—may be employed with equal convenience and efficiency.

The invention consists, briefly speaking, in a standing back-plate adapted to be readily unshipped from the ordinary wood base or cutting board, a horizontal bearing plate forming the arc of a circle graduated into degrees, a swinging frame carried by such plate and adapted to register with and be fixed at any point thereon, and vertically-adjustable saw-carriers supported in such frame.

Certain other features and details of construction are included in my invention for full comprehension of which reference must be had to the accompanying drawings forming part of this specification, similar letters of reference indicating like parts.

In said drawings:—Figure 1 is a plan view, with parts broken away, of a miter-box embodying a simple form of my invention. Fig. 2 is a front view, with parts in section. Fig. 3 is a sectional-end elevation of the miter-box showing the locking device, and saw in position. Fig. 4 is a detail of parts of the saw-carrying devices, showing their adaptability for use in connection with separable saw-backs.

A represents a horizontal wood cutting-board, or base, to the rear edge of which is removably secured a vertical backplate B,

preferably of metal, having a central vertical slot *b* for the saw to work in, being wide enough to allow free play for the blade and saw-back, and by preference a plurality of hand-holes *b*¹ serving the double purpose of lightening the plate and permitting the insertion of the user's fingers to hold the work upon the base-board and up against said back-plate. Bent forward in one piece from the back plate B, or attached thereto, at right angles is a bearing-plate C forming preferably a half circle, the same being graduated into degrees of the circle as marked at *c*, and lightened by perforations *c*¹; a sufficient number of small holes *c*² are also provided along the line of graduation to permit of the insertion of stop-plugs *c*³ at such points and angles as are most generally used in miter-sawing, for convenience of rapid adjustment. Another horizontal plate C¹ also projects rearwardly from the back plate B, for additional bearing purposes.

At the center or radial point of the plates C and C¹ is a vertical up-standing post or stud D acting as a pivot for a swinging frame E, which stud may, if desired, be supplemented by a screwed cap or nut *d* for permanent or temporary retaining purposes. This swinging-frame E consists of a top-bar E¹, (resting and movable upon the plates C, C¹, and held by the post D) upwardly turned end-flanges *e*, *e*, and vertically-disposed guide-plates E² preferably riveted near their upper ends to said flanges, there being two of such guide-plates parallel-arranged at each end and depending at right angles from the top-bar, with tongues *e*¹, *e*¹, serving to fit loosely within corresponding grooves *f*¹, on the edges of the saw-supports F. Each of these saw-supports consists of a bar *f* adapted for vertical movement in the guide-plates E², there being a bar for each pair of the latter and situated to front and rear of the framing described. Each bar *f* has a corresponding central vertical slot *f*² open from its lower end upward for a sufficient distance to easily accommodate any desired hand-saw, and terminating in a wider slot *f*³ which will receive the saw back.

The bars *f*, *f*, project normally above the swinging-frame E, and are long enough to approach the plane of the base-board A sufficiently close to conveniently accommodate all ordinary classes of work, and for convenience of corresponding and simultaneous vertical adjustment are coupled at their up-

per ends by a removable tie-rod G passing through perforations therein close to their upper ends. Below this rod and in the same plane in each of the bars f , I form a vertical line of arbitrarily-spaced perforations g^1 , g^1 adapted to receive a supplementary stop-rod H, or equivalent short pins in each bar, to regulate the distance at which the saw approaches the work.

10 The top-bar E^1 of the swinging frame E has any suitable form and means, such as the V-shaped opening E^2 , whereby proper sight may be had of the graduations c on the semi-circular plate C to effect the proper registration at any desired angle,—and this
15 top-bar E has also a rectangular aperture c^1 at a point just beyond the edge of the plate C to receive the similarly-shaped and spring-controlled spindle, h of the locking device
20 H^1 , the upper end of which takes the form of a push-button h^1 , and the lower end that of a fixed toothed-dog h^2 normally in mesh with a toothed rack c^5 formed on the edge of the semi-circular plate C, the arrangement being such that the dog h^2 may be
25 pushed down clear of the rack c^5 previous to the movement in either direction of the swinging frame E, and returned by the spring when the desired angle has been
30 reached, so as to lock the frame and saw-supports in position for operation of the saw.

In Fig. 4, I have shown a separate saw-back K consisting of an angularly-bent
35 plate adapted to receive any ordinary saw-blade S which the workman can drill at two or more points to receive short pins s the projecting ends of which will form trunnions to rest in grooves or sockets h angularly-disposed in the separate saw-back K,—
40 this latter being supported in the slots f^3 in the bars f , f , and removable at will. Where the back of the saw-blade S is not parallel with the tooth line (as is usually the case)
45 the separate back K will be arranged to correspond, and the positions of the rods G and H in relation to the perforations in the respective adjustable supports varied accordingly.

50 It is believed that from the above description, and from the drawings, the operation and advantages of my improvements will be so apparent to any skilled mechanic as to need no further explanation.

I do not limit myself to the precise details of construction or arrangement shown, as these may be varied and modified according to mechanical judgment without departing from the principles or sacrificing the advantages of my invention. 60

What I claim and desire to secure by Letters Patent is as follows:

1. In a miter-box, the combination with a horizontal base,—and a vertical back-plate having a central slot for the passage of a saw-blade and provided at its top with a horizontal semi-circular plate,—of a swinging frame pivotally-supported on said horizontal plate,—said frame consisting of a horizontal top-piece having upwardly-projecting flanged ends, to each of which ends is secured a pair of guide-plates,—saw supports adjustably-held between said guide-plates, and extending beyond the ends thereof, each of said supports being provided with a series of apertures in the upper end registering with each other, and a cross-bar, fitting in said apertures and adapted to bear against the flanged ends of said top-piece, whereby the saw may be supported at any
75 desired elevation.

2. In a miter-box the combination with a horizontal base, and a vertical back-plate having a central slot for the passage of a saw-blade and provided at its top with a horizontal quadrantal plate, at the radial point of which is an up-standing post,—of a swinging frame supported on said quadrantal plate, said frame consisting of a horizontal top-piece having upwardly-extending flanged ends and an aperture in its median line, toward the rear end, adapted to receive said post, and a sight-opening with an index in its median line, arranged at a point above the scale of the quadrant,—a pair of guide-plates secured to said flanged ends,—saw-supports adjustable between the guide-plates, with ends extending beyond same, each being provided with a series of apertures in the upper end, and stops fitting in said apertures and adapted to bear against the flanged ends of the top-piece. 95

In testimony whereof I have signed in the presence of the two subscribing witnesses.

GEORGE R. HILL.

Witnesses:

MARY A. KELLOND,
GEORGE TAZWELL.