



(51) International Patent Classification:

G10L 15/26 (2006.01) G06F 1/00 (2006.01)
G10L 15/28 (2013.01)

(21) International Application Number:

PCT/US2011/063804

(22) International Filing Date:

7 December 2011 (07.12.2011)

(25) Filing Language:

English

(26) Publication Language:

English

(71) Applicant (for all designated States except US):

HEWLETT-PACKARD DEVELOPMENT COMPANY, L.P.
[US/US]; 11445 Compaq Center Drive W., Houston, Texas 77070 (US).

(72) Inventors; and

(75) Inventors/Applicants (for US only): **LIU, Eric** [US/US]; 950 West Maude Avenue, Sunnyvale, California 94085 (US). **MARTI, Stefan J** [CH/US]; 950 West Maude Avenue, Sunnyvale, California 94085 (US). **KIM, Seung Wook** [KR/US]; 950 West Maude Avenue, Sunnyvale, California 94085 (US).

(74) Agents: **PINKSTON, Caroline S.** et al; Hewlett-Packard Company, Intellectual Property Administration, 3404 East Harmony Road Mail Stop 35, Fort Collins, Colorado 80528 (US).

(81) Designated States (unless otherwise indicated, for every kind of national protection available):

AE, AG, AL, AM, AO, AT, AU, AZ, BA, BB, BG, BH, BR, BW, BY, BZ, CA, CH, CL, CN, CO, CR, CU, CZ, DE, DK, DM, DO, DZ, EC, EE, EG, ES, FI, GB, GD, GE, GH, GM, GT, HN, HR, HU, ID, IL, IN, IS, JP, KE, KG, KM, KN, KP, KR, KZ, LA, LC, LK, LR, LS, LT, LU, LY, MA, MD, ME, MG, MK, MN, MW, MX, MY, MZ, NA, NG, NI, NO, NZ, OM, PE, PG, PH, PL, PT, QA, RO, RS, RU, RW, SC, SD, SE, SG, SK, SL, SM, ST, SV, SY, TH, TJ, TM, TN, TR, TT, TZ, UA, UG, US, UZ, VC, VN, ZA, ZM, ZW.

(84) Designated States (unless otherwise indicated, for every kind of regional protection available):

ARIPO (BW, GH, GM, KE, LR, LS, MW, MZ, NA, RW, SD, SL, SZ, TZ, UG, ZM, ZW), Eurasian (AM, AZ, BY, KG, KZ, MD, RU, TJ, TM), European (AL, AT, BE, BG, CH, CY, CZ, DE, DK, EE, ES, FI, FR, GB, GR, HR, HU, IE, IS, IT, LT, LU, LV, MC, MK, MT, NL, NO, PL, PT, RO, RS, SE, SI, SK, SM, TR), OAPI (BF, BJ, CF, CG, CI, CM, GA, GN, GQ, GW, ML, MR, NE, SN, TD, TG).

Declarations under Rule 4.17:

- as to the identity of the inventor (Rule 4.1 7(i))
- as to applicant's entitlement to apply for and be granted a patent (Rule 4.1 7(H))

Published:

- with international search report (Art. 21(3))

(54) Title: LOW POWER INTEGRATED CIRCUIT TO ANALYZE A DIGITIZED AUDIO STREAM

FIG. 2

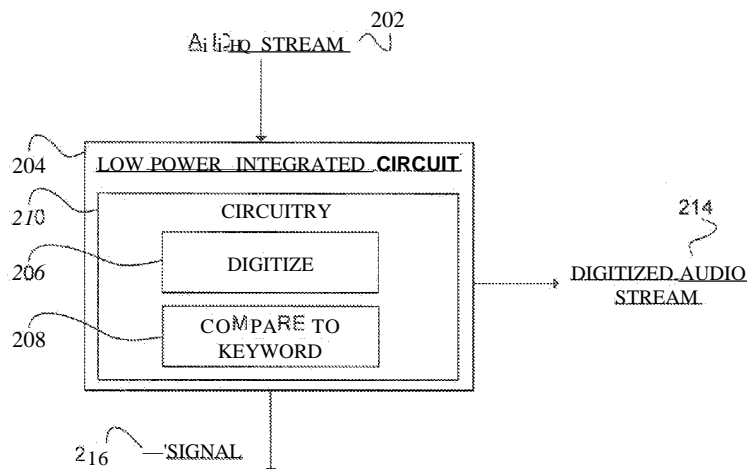

(57) Abstract: Examples disclose a low power integrated circuit to receive and digitize an audio stream. Further, the examples provide the low power integrated circuit to compare the digitized audio stream to a keyword and store the digitized audio stream in a memory. Additionally, the examples also disclose upon recognition of the keyword in the digitized audio stream, the low power integrated circuit transmits a signal to a processor to increase power and analyze the digitized audio stream.

WO 2013/085507 A1

LOW POWER INTEGRATED CIRCUIT TO ANALYZE A DIGITIZED AUDIO STREAM**BACKGROUND**

Computing devices have gained in sophistication to users by processing audio instructions and providing responses. Users can recite audio instructions which may be used to control these computing devices. For example, users can speak to the computing devices to provide information, such as instructions to provide directions to a particular location.

BRIEF DESCRIPTION OF THE DRAWINGS

[0001] In the accompanying drawings, like numerals refer to like components or blocks. The following detailed description references the drawings, wherein:

[0002] FIG. 1 is a block diagram of an example computing device including a low power integrated circuit to analyze an audio stream and a processor to analyze a digitized audio stream in response to detection of a keyword by the integrated circuit;

[0003] FIG. 2 is a block diagram of an example low power integrated circuit for analyzing an audio stream and transmitting a signal to a processor to increase power when a keyword is detected in the audio stream;

[0004] FIG. 3 is a block diagram of an example computing device to analyze a digitized audio stream and a server in communication with the computing device to analyze a text stream generated from the digitized audio stream;

[0005] FIG. 4 is a flowchart of an example method performed on a computing device for receiving an audio stream and determining a response; and

[0006] FIG. 5 is a flowchart of an example method performed on a computing device to compress a digitized audio stream and render a response.

DETAILED DESCRIPTION

[0007] In audio information processing, a user typically activates the application to process audio by pressing a button and/or reciting instructions. Once launching the audio processing application, the user additionally needs to recite explicit instructions they would desire a computing device to perform. Thus, processing speech instructions from a user

can be time consuming and repetitive. In addition, continuously monitoring for instructions from the user consumes much power, draining the battery.

[0008] To address these issues, example embodiments disclosed herein use a low power integrated circuit to continuously monitor for occurrence of a keyword in an audio stream (e.g., the user's speech), while relying on a processor for more thorough analysis of the user's speech. For example, various examples disclosed herein provide for receiving an audio stream in a low power integrated circuit, digitizing the audio stream, and analyzing the digitized audio stream to recognize a keyword. Once recognizing the keyword within the digitized audio stream, the integrated circuit sends a signal to the processor to increase power. Once increasing power to the processor, the digitized audio stream is retrieved to determine a response. This decreases the amount of time consumed for the user to launch the specific audio processing application and prevents repetition of the user's speech. Determining the response from the retrieved audio stream prevents the user from providing additional explicit instructions for the computing device to perform the speech analysis.

[0009] Additionally, in the various examples disclosed herein, once increasing power to the processor, the processor retrieves the digitized audio stream from a memory and converts the digitized audio stream to a text stream. After converting to the text stream, the processor determines a response based on text within the text stream. Determining the response from the text stream reduces the time for the user of the computing device to instruct the computing device. Additionally still, the processor may determine the appropriate response, based on the context of the audio stream. Further, the computing device determines which application needs to execute in order to fulfill the response to the user. Further still, by increasing power to the processor once recognizing the keyword within the digitized audio stream, the computing device consumes less power while listening for the user's speech.

[0010] In one embodiment, the computing device may also determine the response by receiving the response from a server or from the processor. In a further embodiment, the memory maintains the stored digitized audio stream for a predetermined period of time. In this embodiment, the processor can retrieve the digitized audio stream in time increments. For example, the processor may retrieve the complete digitized audio stream or may

retrieve a shorter time interval of the digitized audio stream. The retrieval of the digitized audio stream allows the processor to analyze the context of the audio stream to determine the appropriate response.

[0011] In this manner, example embodiments disclosed herein save a user time by preventing repetitive audio instructions to a computing device since the computing device determines an appropriate response based on the context of the audio stream. Further, the computing device consumes less power while receiving and processing audio streams.

[0012] Referring now to the drawings, FIG. 1 is a block diagram of an example computing device 100 including a low power integrated circuit 104 for receiving an audio stream 102 and a digitize module 106 to digitize the audio stream to provide the digitized audio stream 114 to a memory 112. Further, the low power integrated circuit 104 includes a compare to keyword module 108 to compare the digitized audio stream 114 to a keyword and, based on the recognition of the keyword, transmit a signal 116 to a processor 118 to increase power 122. Further, still, the processor includes an analyze module 120 to analyze the digitized audio stream 114. Embodiments of the computing device 100 include a client device, personal computer, desktop computer, laptop, a mobile device, or other computing device suitable to include components 104, 112, and 118.

[0013] The audio stream 102 is received by the computing device 100, specifically, the low power integrated circuit 104. The audio stream 102 is an input analog signal that is digitized 106 to provide the digitized audio stream 114. Embodiments of the audio stream 102 include speech from a user or audio from another computing device. For example, there may be several computing devices 300 receiving audio streams 102, which may be confusing. Thus, the computing devices may designate one device as a central point to receive the audio stream 102. In this embodiment, the low power integrated circuit 104 operates as part of an ad-hoc network that may be a central unit of one or more computing devices.

[0014] For example, the user may discuss with another person the shortest route from New York to Los Angeles, California. In this example, the audio stream would be the discussion of the shortest route from New York to Los Angeles. In a further embodiment,

the audio stream 102 may include audio for a predetermined period of time. For example, the audio stream 102 may include a few seconds or minutes when received by the low power integrated circuit 104. In this example, the low power integrated circuit 104 may distinguish the audio stream 102 from other audio streams 102.

[0015] The low power integrated circuit 104 includes the module 106 to digitize the audio stream 102 and module 108 to compare the digitized audio stream 114 to the keyword. The low power integrated circuit 104 is an electronic circuit with patterned trace elements on the surface of a material that form interconnections between other electronic components. For example, the low power integrated circuit 104 forms connections between the processor 118 and the memory 112. Embodiments of the low power integrated circuit 104 include a microchip, chipset, electronic circuit, chip, microprocessor, semiconductor, microcontroller, or other electronic circuit capable of receiving audio stream 102 and transmitting signal 116. The low power integrated circuit 104 may continuously monitor the audio stream 102, utilize digitize module 106 to digitize the audio stream, and store the digitized audio stream at the memory 112. As such, further embodiments of the low power integrated circuit 104 include a transmitter, receiver, microphone, or other suitable component to receive the audio stream 102.

[0016] The audio stream is digitized at module 106 to provide the digitized audio stream 114. The digitize module 106 converts the audio stream to a discrete time signal representation. Embodiments of the digitize module 106 include an analog to digital converter (ADC), digital conversion device, instruction, firmware and/or software operating in conjunction with low power integrated circuit 104. For example, the digitize module 106 may include an electronic device to convert an input analog voltage to a digital number proportional to the magnitude of the analog signal.

[0017] Once the audio stream 102 is digitized at module 106, it is compared to the keyword at module 108. The audio stream 102 and at module 108, it is compared against the keyword which operates as an indication to signal 116 the processor 118 to increase power 122 and obtain the digitized audio stream 114 to analyze at module 120. Embodiments of 108 include an instruction, process, operation, logic, algorithm, technique, logical function, firmware and/or software. Once the keyword is recognized, the low power integrated circuit 104 transmits the signal 116 to increase power 122 to the processor 118.

[0018] Embodiments of the keyword include a digital signal, analog signal, pattern, database, commands, directions, instructions, or other representation to compare at module 108. For example, the user of a computing device may discuss the difference between a shrimp and prawn with a friend and subsequently desire to perform a web search to identify the answer. As such, the user may state the predetermined keyword to trigger recognition of the keyword by compare to keyword module 108 and subsequent analysis of the previous discussion by analyze module 120.

[0019] The keyword may include, for example, a phrase, a single keyword, or a single keyword that is private to the user of the computing device. In keeping with the previous example, the keyword may be the phrase, "Computer, what do you think?". In this example, the phrase causes the low power integrated circuit 104 to send the signal 116 to the processor 118 to obtain the digitized audio stream 114 which may include the audio before or after the phrase. Thus, the user does not need to repeat the instructions since the processor 118 analyzes the digitized audio stream 114 to determine the context of the audio stream 102 for an appropriate response. Yet, in a further example, the single keyword may include "Shazam." Thus, as a specific example, when the user speaks the word "Shazam," circuit 104 may detect the keyword and transmit the signal 116 to instruct the processor 118 to obtain the digitized audio stream 114 and convert the stream to a text stream. Supposing the text stream is an instruction to compose a text message to the user's mother, the appropriate response would be to compose the text message. Thus, as described above, using the predetermined keyword(s), the low power integrated circuit 104 recognizes when the user of the computing device needs to complete a further response, such as directions or perform a web search.

[0020] In a further embodiment of module 108, when no keyword is recognized within the digitized audio stream 114, the low power integrated circuit 104 continues monitoring for another audio stream 102 which is digitized at module 106 and stored in the memory 112. In yet a further embodiment, the low power integrated circuit 104 compresses the digitized audio stream 114 and this compressed digitized audio stream is used to recognize the keyword by comparing it to the keyword at module 108.

[0021] The memory 112 stores and/or maintains the digitized audio stream 114. Embodiments of the memory 112 may include a memory buffer, cache, non-volatile

memory, volatile memory, random access memory (RAM), an Electrically Erasable Programmable Read-Only Memory (EEPROM), storage drive, a Compact Disc Read-Only Memory (CDDROM), or other memory capable of storing and/or maintaining the digitized audio stream 114.

[0022] The digitized audio stream 114 is stored in the memory 112. Embodiments may include the low power integrated circuit 104 compressing the audio stream 102 after the digitization module 106 to obtain a compressed digitized audio stream prior to placement in the memory 112. Although FIG. 1 depicts the digitized audio stream 114 stored in the memory 112, the digitized audio stream may also be stored in a memory on the low power integrated circuit 104. In a further embodiment, digitized audio stream 114 includes a predetermined amount of time of an audio stream 102. In this embodiment, once the audio stream 102 is received for a predetermined period of time, such as a few seconds or minutes, this predetermined period of time of the audio stream 102 is digitized and stored in the memory 112 for the processor 118 to obtain and/or retrieve. Further in this embodiment, when another audio stream 102 is received by the low power integrated circuit 104 and digitized, the prior digitized audio stream in the memory is replaced with the more current digitized audio stream 114. Thus, the processor 118 obtains and/or retrieves the most current audio stream 102. In this embodiment, the memory operates as a first-in-first-out buffer to provide the most current audio stream 102.

[0023] The signal 116 is transmitted from the low power integrated circuit 104 to the processor 118 upon recognition of the keyword within the digitized audio stream 114. The signal 116 instructs the processor 118 to increase power 122 and analyze the digitized audio stream 114 from the memory 112. Embodiments of the signal 116 include a communication, transmission, electrical signal, instruction, digital signal, analog signal, or other type of communication to increase power 122 to the processor 118. A further embodiment of the signal 116 includes an interrupt transmitted to the processor 118 upon recognition of the keyword within the digitized audio stream 114.

[0024] The processor 118 receives the signal 116 to increase power 122 and obtains the digitized audio stream 114 to analyze at module 120. Embodiments of the processor 118 may include a central processing unit (CPU), visual processing unit (VPU),

microprocessor, graphics processing unit (GPU), or other programmable device suitable to analyze 120 the digitized audio stream 114.

[0025] Once the processor 118 obtains the digitized audio stream 114 from the memory 112, the processor analyzes the digitized audio stream 114 at module 120. Embodiments of the analyze module 120 include an instruction, process, operation, logic, algorithm, technique, logical function, firmware and/or software the processor 118 may fetch, decode, and/or execute. Additional embodiments of module 120 include converting the digitized audio stream 114 to a text stream to determine an appropriate response based on the context of the audio stream 102. Further embodiments of module 120 include determining a response to render to the user of the computing device 100 as will be seen in later figures.

[0026] The power 122 supplies electrical energy in the form of electrical potential to the processor 118. Specifically, the power 122 increases electrical energy to the processor 118 once receiving the signal 116 from the low power integrated circuit 104. Increasing the power 122 to the processor 118 wakes or triggers the processor 118 to obtain the digitized audio stream 114. Embodiments of the power 122 include a power supply, power management device, battery, energy storage, electromechanical system, solar power, power plug, or other device capable of delivering power 122 to the processor 118. In a further embodiment, power 122 supplies the electrical energy to the computing device 100.

[0027] Referring now to FIG. 2, is a block diagram of an example low power integrated circuit 204 for analyzing an audio stream 202 and transmitting a signal 216 to a processor to increase power when a keyword is detected in the audio stream 202. The low power integrated circuit 204 includes circuitry 210 to produce a digitized audio stream 214 using a digitize circuitry 206 and detects the keyword by a compare circuitry 208, and upon recognition of the keyword in the digitized audio stream 214, transmits a signal 216.

[0028] The audio stream 202 is received by the low power integrated circuit 204. The audio stream 202 may be similar in structure to audio stream 102 of FIG. 1.

[0029] The low power integrated circuit 204 includes the circuitry 210 to digitize the audio stream 202 and compare the digitized audio stream 214 to a keyword. The low

power integrated circuit 204 may be similar in functionality and structure of the low power integrated circuit 104 as above in FIG. 1.

[0030] The circuitry 210 includes digitize circuitry 206 and compare circuitry 208. Embodiments of the circuitry 210 include logic, analog circuitry, electronic circuitry, digital circuitry, or other circuitry capable of digitizing the audio stream 102 and comparing the digitized audio stream 214 to the keyword. In further embodiments, the circuitry includes an application and/or firmware which may be utilized independently and/or in conjunction with the low power integrated circuit 204 to fetch, decode, and or execute circuitry 206 and 208.

[0031] The audio stream 202 is received and digitized by circuitry 206 to produce the digitized audio stream 214. The digitize circuitry 206 is a type of conversion for the audio stream 202. Further, the digitize circuitry 206 may be similar in functionality of the digitize module 106 as described in connection with FIG. 1.

[0032] The low power integrated circuit 204 receives the audio stream 202 to digitize at circuitry 206 and produces the digitized audio stream 214. The digitized audio stream 214 may be similar in structure to the digitized audio stream 114 as described in connection with FIG. 1. Further, although FIG. 2 depicts the digitized audio stream 214 outside of the low power integrated circuit 204, the digitized audio stream 214 may also be located within the low power integrated circuit 204. The digitized audio stream 214 located within the low power integrated circuit 204 is used at circuitry 208 to compare to a keyword. In another embodiment, the digitized audio stream 214 is stored and/or maintained in a memory.

[0033] The circuitry 208 included in the circuitry 210 of the low power integrated circuit 204, compares the digitized audio stream 214 to the keyword. Further, 208 is used to recognize the keyword within the digitized audio stream 214 to transmit the signal 216 to increase power to the processor. The compare circuitry 208 may be similar in functionality to the module 108 as described in connection with FIG. 1.

[0034] The signal 216 instructs a device to increase power upon recognition of the keyword within the digitized audio stream 214 by compare circuitry 208. The signal 216 may be similar in structure and functionality to signal 116 of FIG. 1. An embodiment of the signal 216 includes instructing a processor to increase power and analyze the digitized audio stream 214 from the memory. In this embodiment, the signal 216 instructs the

processor to obtain the digitized audio stream 214 to analyze and determine a response based on the keyword recognition at circuitry 208.

[0035] FIG. 3 is a block diagram of an example computing device 300 to analyze a digitized audio stream 314 and a server 326 in communication with the computing device 300 to analyze a text stream 324 generated from the digitized audio stream 314. The computing device 300 includes a low power integrated circuit 304, a memory 312, a processor 318, an output device 328, and the server 326. Specifically, FIG. 3 depicts the text stream 324 processed by the server 326 or the processor 318 to render a response to a user of the computing device on the output device 324. The computing device 300 may be similar in structure and functionality of the computing device 100 as described in connection with FIG. 1.

[0036] The audio stream 302 is received by the computing device 300, specifically, the low power integrated circuit 304. The audio stream 302 may be similar in structure to the audio stream 102 and 202 in FIG. 1 and FIG. 2, respectively.

[0037] The low power integrated circuit 304 includes a digitize module 306 and an analyze module 308. In one embodiment, the low power integrated circuit 304 includes circuitry to comprise modules 306 and 308. The low power integrated circuit 304 may be similar in structure and functionality of the low power integrated circuit 104 and 204 described in connection with FIG. 1 and FIG. 2, respectively.

[0038] The audio stream 302 once received by the computing device 300 is digitized 306 to produce a digitized audio stream 314. The digitize module 306 may be similar in structure and functionality to the digitize module 106 and digitize circuitry 206 in FIG. 1 and FIG. 2, respectively. In a further embodiment, once the audio stream 302 is digitized at module 306, the low power integrated circuit 304 transmits the digitized audio stream 314 to the memory 312 to store and/or maintain.

[0039] Once the audio stream 314 is digitized, the low power integrated circuit analyzes the digitized audio stream 314 at module 308. In one embodiment, module 308 compares a keyword to the digitized audio stream 114. In this embodiment, 308 includes the functionality of the compare module 108 as above in FIG. 1.

[0040] The memory 312 stores the digitized audio stream 314 from the low power integrated circuit 304. In one embodiment, the memory 312 maintains the digitized audio stream 314 received during a predetermined period of time. For example, the audio stream 302 may be monitored for the predetermined time of a few seconds and as such, this few seconds of the audio stream 302 is digitized at module 306 and sent to the memory 312. In this example, the memory 312 stores the digitized audio stream 314 of the few seconds to be retrieved and/or obtained by the processor 318 to analyze once receiving the signal 316. Also, in this example, when another audio stream 302 of a few seconds is received and digitized, this other digitized audio stream 314 replaces the prior digitized audio stream 314. This allows the memory 312 to maintain the most recent audio stream 302 for the processor 318 to obtain and/or retrieve. The memory 312 may be similar in structure and functionality of the memory 112 as described in connection with FIG. 1.

[0041] The audio stream 302 is digitized 306 to produce the digitized audio stream 314. The digitized audio stream 314 is stored and/or maintained in the memory 312. In an embodiment, the processor 318 obtains the digitized audio stream 314 to analyze at module 320 once receiving the signal 316. The digitized audio stream 314 may be similar in structure and functionality of digitized audio stream 114 and 214 as described in connection with FIG. 1 and FIG. 2, respectively.

[0042] The signal 316 is a transmission from the low power integrated circuit 304 to the processor 316 to increase power 322. In an embodiment of the signal 316, additionally instructs the processor 316 to obtain the digitized audio stream 314 to analyze at module 320. The signal 316 may be similar in structure and functionality of the signal 116 and 216 as described in connection with FIG. 1 and FIG. 2, respectively.

[0043] The power 322 supplies electrical energy to the processor 318 and/or computing device 300. The power 322 may be similar in structure and functionality of the power 122 as described in connection with FIG. 1.

[0044] The processor 318 includes the analyze module 320 and text stream 324. Specifically, the processor 318 receives the signal 316 to increase power 322. Once receiving this signal 316, the processor 318 obtains the digitized audio stream 314 to analyze at module 320. In a further embodiment, the processor 318 converts the digitized

audio stream 314 to the text stream 324. In this embodiment, the text within the text stream 324 dictates a response for the computing device 300. The text stream is a string of finite sequence of symbols or representations from an alphabet, numbered set, or alphanumeric set. For example, the digitized audio stream 314 may be in a binary language, thus the processor translates bytes of the binary representation to a word. In a further example, the digitized audio stream 314 may be in a language representative of words and/or numbers, thus the processor 318 translates this language into text the processor 318 comprehends. Embodiments of the response include performing a web search, dialing a phone number, opening an application, recording text, streaming media, composing a text message, listing direction, or speaking directions. In a further embodiment, the processor 318 determines the response to render to a user of the computing device 300. The processor 318 may be similar in structure and functionality of the processor 118 as described in connection with FIG. 1.

[0045] The processor 318 analyzes the stored digitized audio stream 314 at module 320. Embodiments of the analyze module 320 include transmitting the digitized audio stream 314 obtained from the memory 314 to the server 326. Other embodiments of module 320 include converting the digitized audio stream 314 obtained from the memory 312 to the text stream 324 and transmitting the text stream 324 to the server 326. Other embodiments of module 320 include converting the digitized audio stream 314 to the text stream 324 to determine the appropriate response by analyzing the context of the audio stream 302. For example, the digitized audio stream 314 may be converted to the text stream 324 at module 320 and the processor 318 may utilize a natural language processing to analyze the text within the text stream 324 to determine the appropriate response based on the context of the audio stream 302.

[0046] The text stream 324 includes text to determine the appropriate response for the computing device 300. In one embodiment, the text stream 324 is processed by the processor to determine the appropriate response to render to the user of the computing device 300 on the output device 328. In another embodiment, the text stream 324 is processed by the server 326 to determine the appropriate response which is transmitted to the computing device 300. In this embodiment, the response is sent from the server 326 to the computing device 300. In a further embodiment, the computing device 300 renders

the response to the user of the computing device 300. For example, the text stream 324 may include text that discusses sending a text message to mom. Thus, the text within the text stream 324 dictates for the computing device 300 to respond by composing a text message to mom.

[0047] The server 326 provides services across a network and may include, for example, a web server, a network server, a Local Area Network (LAN) server, a file server, or any other computing device suitable to process the text stream 324 to transmit the response to the computing device 300.

[0048] The output device 328 renders the response as determined from the text within the text stream 324 to the user of the computing device 300. Embodiments of the output device 328 include a display device, a screen, or a speaker to render the response to a user of the computing device 300. In keeping with the text message to mom example, the user of the computing device 300 may have a display that shows the text message being composed to mom and/or speaker to communicate to the user the text message.

[0049] Turning now to FIG. 4, a flowchart of an example method performed on a computing device to receive an audio stream and determine a response. Although FIG. 4 is described as being performed on computing device 100 as in FIG. 1, it may also be executed on other suitable components as will be apparent to those skilled in the art. For example, FIG. 4 may be implemented in the form of executable instructions on a machine readable storage medium such as memory 112.

[0050] At operation 402, the computing device operating in conjunction with a low power integrated circuit receives an audio stream. In one embodiment, the audio stream is of a predetermined amount of time. For example, the audio stream may be a few seconds or milliseconds. In this embodiment, the computing device may continuously monitor audio. In further embodiments, the audio stream includes at least one of a speech from a user or audio from the other computing device.

[0051] At operation 404, the low power integrated circuit operating in conjunction with the computing device digitizes the audio stream received at operation 402 to produce a digitized audio stream. Embodiments of operation 404 include the use of an analog to digital converter (ADC), digital conversion device, instruction, firmware, and/or software

operating in conjunction with the low power integrated circuit. Embodiments of operation 404 include transmitting the digitized audio stream to a memory. Further embodiments of 404 include compressing the audio stream received at operation 402, while another embodiment of 404 includes compressing the digitized audio stream.

[0052] At operation 406, the digitized audio stream produced at operation 404 is stored in the memory. Embodiments of operation 406 include the memory storing and/or maintaining the digitized audio stream. In another embodiment of operation 406, the audio stream received during the predetermined amount of time at operation 402 is digitized at operation 404, thus when another audio stream is received at operation 402 and digitized at operation 404, this current digitized audio stream replaces the prior digitized audio stream. In this embodiment, the memory maintains the stored digitized audio stream received during the predetermined period of time prior to the current time.

[0053] At operation 408, the low power integrated circuit analyzes the digitized audio stream produced at operation 404. Embodiments of operation 408 include processing the digitized audio stream while other embodiments include comparing the digitized audio stream to a keyword. In these embodiments of operation 408, the low power integrated circuit processes the digitized audio stream for the keyword. Upon recognition of the keyword within the digitized audio stream, the method moves to operation 410 to transmit a signal. In a further embodiment, if the low power integrated circuit does not recognize the keyword within the digitized audio stream, the method returns to operation 402. Yet, in a further embodiment includes comparing the digitized audio stream to an analog or digital representation that indicates the user of the computing device desires a response by the computing device. In yet a further embodiment, operations 402, 404, 406, and 408 occur in parallel. For example, if the computing device analyzes the digitized audio stream at 408, the integrated circuit continues receiving audio streams at operation 402, digitizing, and storing the audio stream at operations 404 and 406.

[0054] At operation 410, the low power integrated circuit transmits the signal to the processor to increase power. Specifically, upon recognition of the keyword within the digitized audio stream, the low power integrated circuit transmits a signal to the processor to increase power. In an embodiment of operation 410, the processor increases power or electrical energy delivered to the processor and/or the computing device.

[0055] At operation 412, the processor obtains the stored digitized audio stream from the memory at operation 406. In one embodiment of operation 412, the memory transmits the digitized audio stream to the processor, while in another embodiment of operation 412, the processor retrieves the digitized audio stream from the memory.

[0056] At operation 414, the processor converts the digitized audio stream obtained at operation 412 to a text stream. After converting the digitized audio stream to the text stream, the processor analyzes the text within the text stream to determine the appropriate response. Embodiments of operation 414 include using speech to text (STT), voice to text, digital to text, or other type of text conversion. A further embodiment of operation 414 includes using a natural language processing after conversion to the text stream. In this embodiment, the computing device processes the text within the text stream to determine an appropriate response based on the context of the audio stream received at operation 402. For example, once detecting the keyword within the digitized audio stream at 408, the processor obtains at operation 412, and the digitized audio stream is converted to the text stream at operation 414. In a further example, the audio stream may include a conversation regarding directions between two locations, thus once this digitized audio stream is converted at operation 412 to the text stream,- the processor can determine the appropriate response by analyzing the text within the text stream.

[0057] At operation 416, the processor determines the response based on the text stream produced at operation 414. Embodiments of the response include performing a web search, dialing a phone number, opening an application, recording text, streaming media, composing a text message, listing directions, or speaking directions. In one embodiment, the text within the text stream dictates the appropriate response for the processor. In a further embodiment, the response is rendered to a user of the computing device. For example, the text stream may include speech inquiring how to reach China and as such directions to China would be the appropriate response. Additionally, in this example, a map display listing and/or speaking directions to China may be included.

[0058] Referring now to FIG. 5, a flowchart of an example method performed on a computing device to compress a digitized audio stream and render a response to a user of the computing device. Although FIG. 5 is described as being performed on computing

device 300 as above in FIG. 3, it may also be executed on other suitable components as will be apparent to those skilled in the art. For example, FIG. 5 may be implemented in the form of executable instructions on a machine readable storage medium such as memory 312.

[0059] At operation 502, the computing device compresses a digitized audio stream. In one embodiment, operation 502 is performed in conjunction with operation 404 prior to operation 406 in FIG. 4. For example, once having digitized the received audio stream, a low power integrated circuit operation in conjunction with the computing device may compress the digitized audio stream to reduce the data byte size of the stream. In this example, the compression of the digitized audio stream occurs prior to being stored in a memory at operation 406. In a further embodiment, operation 502 is performed prior to receiving the digitized audio stream at operation 412 in FIG. 4. For example, the processor may perform operation 502 to compress the digitized audio stream from the memory while in another example, the memory may compress the digitized audio stream prior to the processor obtaining the digitized audio stream. In yet a further embodiment of operation 502, the compressed digitized audio stream is analyzed to recognize a keyword such as at step 408 in FIG. 4.

[0060] At operation 504, the computing device renders a response to the user of the computing device. Embodiments of operation 504 include occurring during or after operation 416 in FIG. 4. For example, once the processor determines the appropriate response, this response may be rendered to the user of the computing device. In a further embodiment, the response may be rendered to the user on an output device, such as a display screen or speaker, operating in conjunction with the computing device. For example, when the user discusses the difference between a shrimp and prawn, the processor may launch a web search application, thus performing the web search of difference between the shrimp and prawn. The performed web search may be rendered on the display device of the computing device to the user. In a further example, the computing device audibly recites the differences between the shrimp and prawn through a speaker to the user. In these embodiments, the computing device operates with an audio stream to determine a response rather than the user instructing the computing device.

[0061] The embodiments described in detail herein relate to digitizing an audio stream to detect a keyword and based upon recognition of the keyword within the digitized audio stream, transmitting a signal to a processor to increase power and further analyze the digitized audio stream to determine a response. In this manner, example embodiments save a user time by preventing repetitive audio instructions to a computing device, while reducing power consumption of the computing device.

CLAIMSWe claim:

1. A method executed by a computing device including a low power integrated circuit and a processor, the method comprising:
 - receiving an audio stream;
 - digitizing the audio stream;
 - storing the digitized audio stream in a memory;
 - analyzing the digitized audio stream for recognition of a keyword using the low power integrated circuit;
 - upon recognition of the keyword within the digitized audio stream, transmitting a signal to increase power from the low power integrated circuit to the processor;
 - transmitting the stored digitized audio stream from the memory to the processor;
 - converting the digitized audio stream to a text stream using the processor; and
 - determining a response for the processor based on the text stream.
2. The method of claim 1, further comprising:
 - compressing the digitized audio stream into a compressed digitized audio stream,
 - wherein the analyzing comprises analyzing the compressed digitized audio stream for recognition of the keyword.
3. The method of claim 1, further comprising:
 - rendering the response to a user of the computing device.
4. The method of claim 3, wherein the response includes at least one of performing a web search, dialing a phone number, opening an application, recording text, streaming media, composing a text message, listing directions, or speaking directions.
5. The method of claim 1, wherein the memory maintains the stored digitized audio stream received during a predetermined period of time prior to a current time.

6. The method of claim 1 wherein determining the response for the processor comprises one of:
- receiving the response from a server based on analysis of the text stream by the server, and
 - determining the response based on analysis of the text stream by the processor.
7. The method of claim 1 wherein the audio stream includes at least one of speech from a user, speech from another computing device, and audio from the another computing device.
8. A computing device comprising:
- a low power integrated circuit to:
 - upon receiving an audio stream, digitize the audio stream to store in a memory,
 - analyze the digitized audio stream to recognize a keyword, and
 - upon recognition of the keyword in the digitized audio stream, transmit a signal to increase power to a processor; and
 - a processor to:
 - increase power based on the signal from the low power integrated circuit,
- and
- analyze the digitized audio stream to determine a response.
9. The computing device of claim 8, wherein to analyze the digitized audio stream, the processor is further to:
- based on receiving the signal to increase power, retrieve the digitized audio stream from the memory;
 - convert the digitized audio stream to a text stream; and
 - determine the response as dictated by the text in the text stream.

10. The computing device of claim 8 wherein, to analyze the digitized audio stream, the processor is further to:

based on receiving the signal to increase power, retrieve the digitized audio stream from the memory;

transmit the digitized audio stream or a text stream generated from the digitized audio stream to a server to determine the response; and

receive the response from the server.

11. The computing device of claim 8 wherein the low power integrated circuit is further to:

compress the digitized audio stream to obtain a compressed digitized audio stream, and

analyze the compressed digitized audio stream to recognize the keyword.

12. The computing device of claim 8 further comprising:

an output device to render the response to a user of the computing device.

13. The computing device of claim 8, wherein to analyze the digitized audio stream to recognize the keyword, the low power integrated circuit compares the digitized audio stream to the keyword.

14. A low power integrated circuit, comprising:

circuitry to:

receive an audio stream;

digitize the audio stream;

store the digitized audio stream in a memory;

compare the digitized audio stream to a keyword; and

upon recognition of the keyword in the digitized audio stream, transmit a signal to instruct a processor of a computing device to increase power and analyze the stored digitized audio stream from the memory.

15. The low power integrated circuit of claim 14, wherein the memory maintains the stored digitized audio stream for a predetermined period of time.

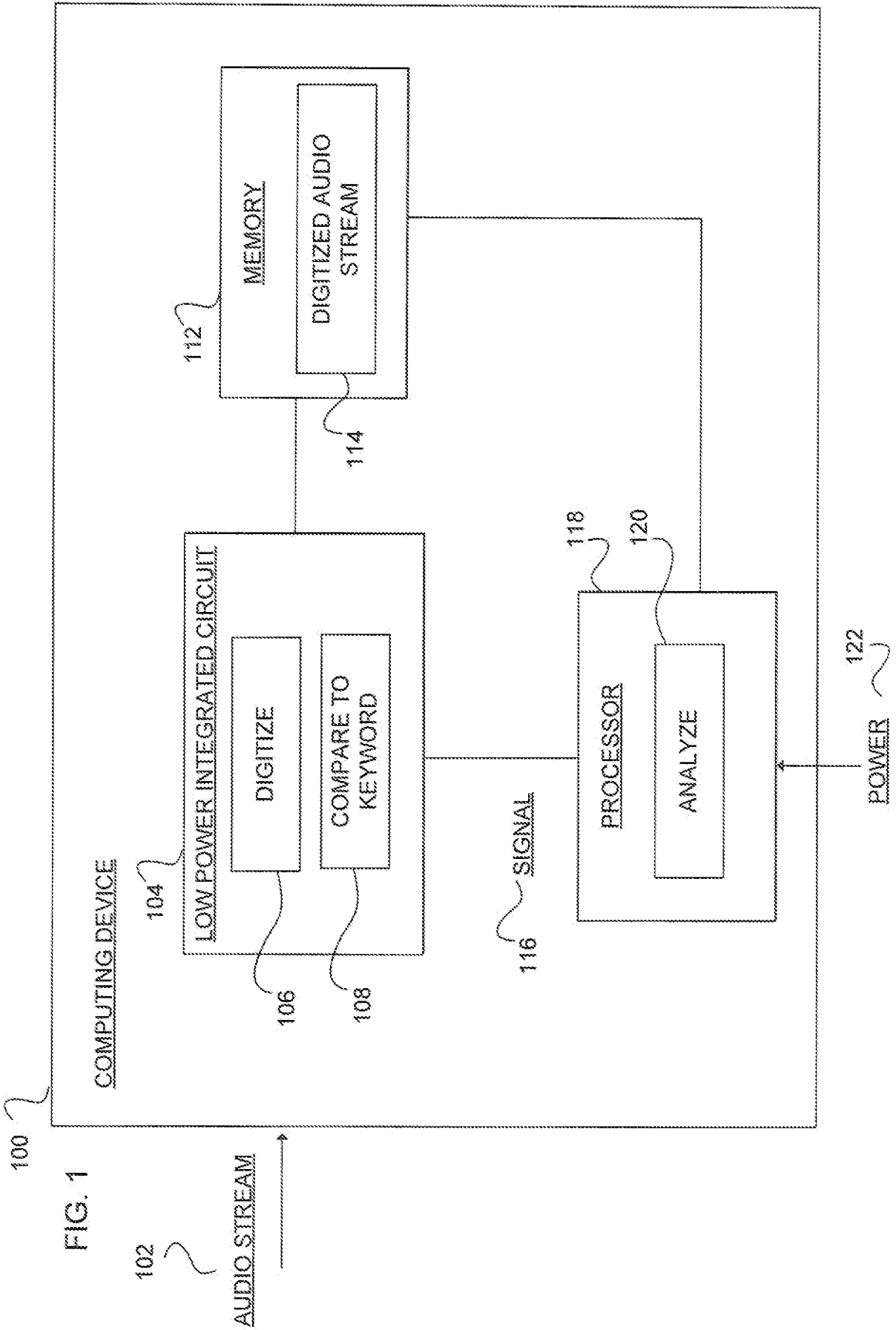

FIG. 2

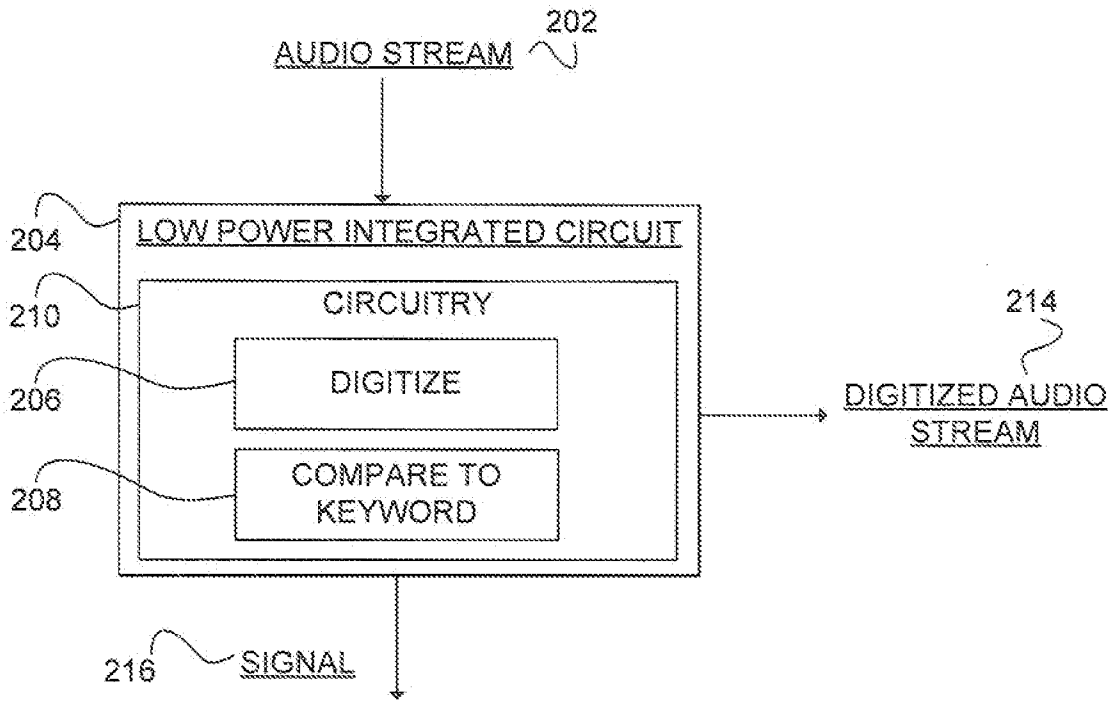

FIG. 3

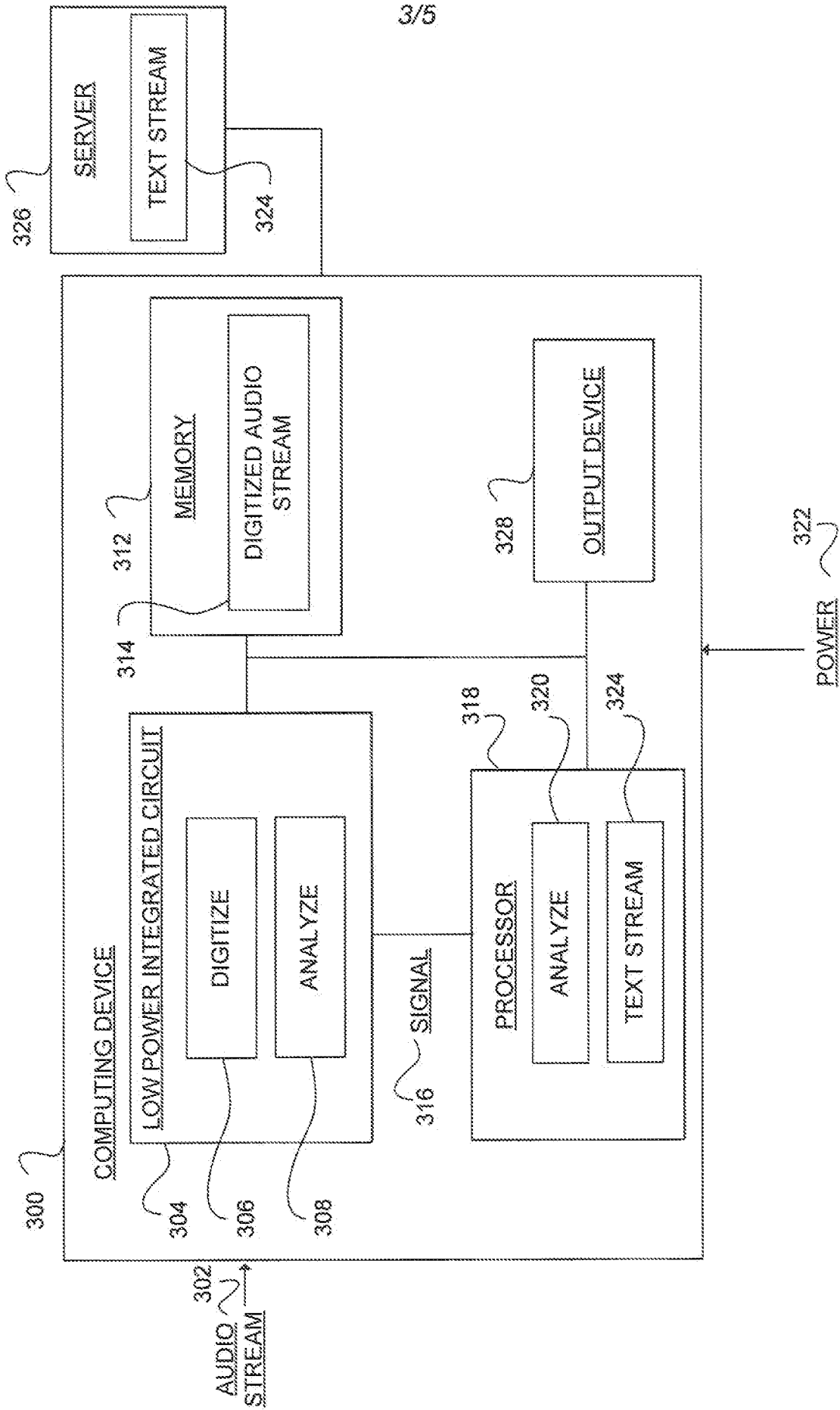
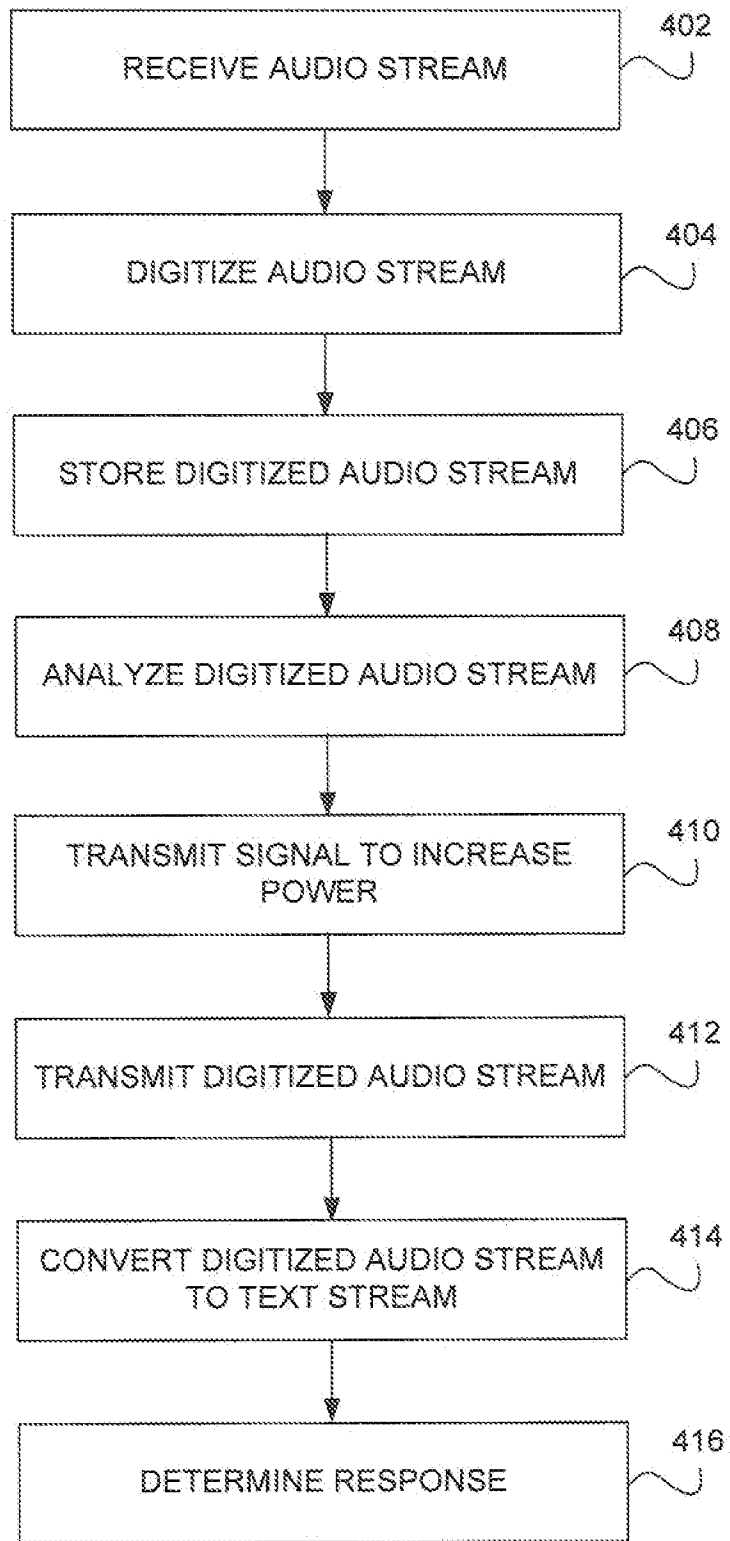

FIG. 4

4/5



5/5

FIG. 5

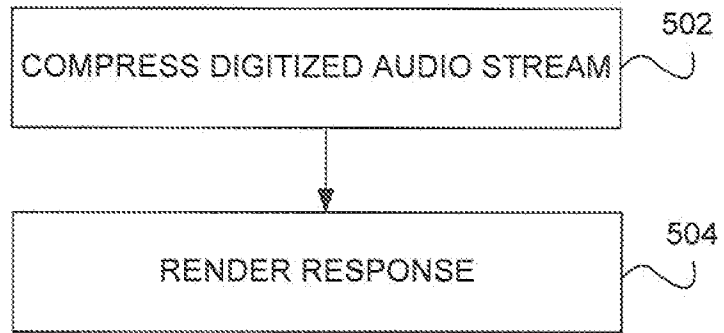

INTERNATIONAL SEARCH REPORT

International application No.
PCT/US2011/063804**A. CLASSIFICATION OF SUBJECT MATTER***GIOL 15/26(2006.01)i, GIOL 15/28(2006.01)1, G06F 1/00(2006.01)1*

According to International Patent Classification (IPC) or to both national classification and IPC

B. FIELDS SEARCHED

Minimum documentation searched (classification system followed by classification symbols)

GIOL 15/26; H04N 5/232; GIOL 15/00; GIOL 13/00; G06Q 50/00; G10L 17/21

Documentation searched other than minimum documentation to the extent that such documents are included in the fields searched

Korean utility models and applications for utility models

Japanese utility models and applications for utility models

Electronic data base consulted during the international search (name of data base and, where practicable, search terms used)

eKOMPASS(KIPO internal) & Keywords: voice recognition, audio stream, and integrated circuit

C. DOCUMENTS CONSIDERED TO BE RELEVANT

Category*	Citation of document, with indication, where appropriate, of the relevant passages	Relevant to claim No.
X	KR 10-0447667 B1 (이경복) 08 September 2004 See page3, lines 21-53, and claim1.	1-15
A	US 2004-0002862 A1 (JONG-HO KIM et al.) 01 January 2004 See the whole documents.	1-15
A	US 6253176 B1 (JANEK; GABOR et al.) 26 June 2001 See the whole documents.	1-15
A	W0 2008-004037 A1 (SONY ERICSSON MOBILE COMMUNICATIONS AB et al.) 10 January 2008 See the whole documents.	1-15

 Further documents are listed in the continuation of Box C. See patent family annex.

* Special categories of cited documents:

"A" document defining the general state of the art which is not considered to be of particular relevance

"E" earlier application or patent but published on or after the international filing date

"L" document which may throw doubts on priority claim(s) or which is cited to establish the publication date of citation or other special reason (as specified)

"O" document referring to an oral disclosure, use, exhibition or other means

"P" document published prior to the international filing date but later than the priority date claimed

"T" later document published after the international filing date or priority date and not in conflict with the application but cited to understand the principle or theory underlying the invention

"X" document of particular relevance; the claimed invention cannot be considered novel or cannot be considered to involve an inventive step when the document is taken alone

"Y" document of particular relevance; the claimed invention cannot be considered to involve an inventive step when the document is combined with one or more other such documents, such combination being obvious to a person skilled in the art

"&" document member of the same patent family

Date of the actual completion of the international search

28 AUGUST 2012 (28.08.2012)

Date of mailing of the international search report

29 AUGUST 2012 (29.08.2012)

Name and mailing address of the ISA/KR

 Korean Intellectual Property Office
 189 Cheongsu-ro, Seo-gu, Daejeon Metropolitan
 City, 302-70 1, Republic of Korea

Facsimile No. 82-42-472-7140

Authorized officer

YANG, Seong Ji

Telephone No. 82-42-481-81 17



INTERNATIONAL SEARCH REPORT

Information on patent family members

International application No.

PCT/US201 1/063804

Patent document cited in search report	Publication date	Patent family member(s)	Publication date
KR 10-0447667 B1	08.09.2004	None	
US 2004-0002862 A1	01.01.2004	CN 100359507 CO CN 1487433 A CN 1487433 CO JP 04-85 1684 B2 JP 2004-038 163 A KR 10-0464420 B1 KR 10-0464428 B1 KR 10-0486252 B1 KR 10-0486307 B1 KR 10-0498447 B1 TW 1225640B TW 225640 A TW 225640 B us 2004-000286 1 A1 us 7356466 B2	02.01.2008 07.04.2004 02.01.2008 28.10.2011 05.02.2004 03.01.2005 03.01.2005 03.05.2005 29.04.2005 14.11.2005 21.12.2004 21.12.2004 21.12.2004 01.01.2004 08.04.2008
US 6253 176 B1	26.06.2001	AT 254327 T DE 698 19690 D1 DE 698 19690 T2 EP 09620 14 A2 EP 09620 14 A2 EP 09620 14 B1 JP 04-827274 B2 JP 200 1-5156 11 T JP 4827274 B2 KR 10-2000-0075828 A WO 99-35640 A2 WO 99-35640 A3	15.11.2003 18.12.2003 12.08.2004 08.12.1999 02.04.2003 12.11.2003 22.09.2011 18.09.2001 30.11.2011 26.12.2000 15.07.1999 16.09.1999
WO 2008-004037 A1	10.01.2008	AT 489807 T CN 10 1480039 A DE 6020060 18539 D1 EP 2041957 A1 EP 2041957 B1 JP 04-9758 13 B2 JP 2009-543396 A KR 10-1163273 B1 KR 20090025362A US 2008-0036869 A1 US 8207936 B2	15.12.2010 08.07.2009 05.01.2011 01.04.2009 24.11.2010 20.04.2012 03.12.2009 05.07.2012 10.03.2009 14.02.2008 26.06.2012