



EUROPEAN PATENT SPECIFICATION

Date of publication of patent specification :
30.09.92 Bulletin 92/40

Int. Cl.⁵ : **G04C 3/00, G04C 1/06**

Application number : **89109092.0**

Date of filing : **19.05.89**

Electronic watch.

Priority : **19.05.88 JP 122582/88**

Proprietor : **SEIKO EPSON CORPORATION**
4-1, Nishishinjuku 2-chome
Shinjuku-ku Tokyo-to (JP)

Date of publication of application :
23.11.89 Bulletin 89/47

Inventor : **Miyazawa, Osamu**
c/o Seiko Epson Corp. 3-5, Owa 3-chome
Suwa-shi Nagano-ken (JP)

Publication of the grant of the patent :
30.09.92 Bulletin 92/40

Designated Contracting States :
CH DE FR GB LI

Representative : **Blumbach Weser Bergen**
Kramer Zwirner Hoffmann Patentanwälte
Radeckestrasse 43
W-8000 München 60 (DE)

References cited :
DE-C- 940 722
GB-A- 890 349
US-A- 3 978 654
PATENT ABSTRACTS OF JAPAN, vol. 012359
(P-762), 27th June 1988; & JP-A-63 109 389
(SEIKO EPSON CORP.) 14-05-1988

EP 0 342 705 B1

Note : Within nine months from the publication of the mention of the grant of the European patent, any person may give notice to the European Patent Office of opposition to the European patent granted. Notice of opposition shall be filed in a written reasoned statement. It shall not be deemed to have been filed until the opposition fee has been paid (Art. 99(1) European patent convention).

Description

BACKGROUND OF THE INVENTION

Field of the Invention

The present invention generally relates to an electronic watch which makes a smooth movement of a second hand, and more particularly, to a structure of a wheel train thereof.

A prior art electronic watch (e.g. Japanese Utility Model Application No. 147940/1987 or PAJ, vol. 012359 [P-762], & JP-A-63-109389) is, as illustrated in Fig. 3, composed of: an accumulating means consisting of a hair wheel 9, a hair spring 10 and a hair pinion 11; and a control means consisting of a viscous rotor spindle 13, a viscous rotor 14, a viscous fluid 17 and a container 19, these means being constructed separately. Based on the arrangement which is disclosed in Japanese Patent Publication No. 47512/1981, as depicted in Fig. 4, a second hand spindle 3, a minute hand spindle 40 and an hour hand spindle 47 are disposed about the center of a base plate 21. Superposed on these spindles are a driving magnet 43, a driven magnet 44 immersed in a viscous fluid and a linkage magnet 45. With this arrangement, the rotation of a fourth wheel 15 is smoothly transmitted by the magnetic attraction.

The foregoing conventional electronic watch presents the following problems. As shown in the example of Fig. 3, the accumulating means and the control means are constructed separately from each other, which requires intermediate wheels 12 and 48 for linking these two means. This kind of arrangement entails a relatively large area and is unsuitable for miniaturization. In the example depicted in Fig. 4, when the hour hand is mounted, there are superposed hour hand spindle 47, minute hand spindle 40 mounted with the minute hand, the fourth wheel 15 for driving second hand spindle 3 and a third wheel 25 for linking the fourth wheel to a second wheel 39. Added to this configuration are driving magnet 43, driven magnet 44, linkage magnet 45 and a second wheel train receiver 46 for retaining these magnets, as a result of which it is difficult to decrease the thickness of watch because of its thick movement.

It is a primary object of the present invention to eliminate the above-described problems and to provide a wheel train structure suited to miniaturization and also to thinning of a watch which makes a smooth movement of its hand.

This object is achieved with an electronic watch as claimed in claim 1.

According to one aspect of the invention, there is provided an electronic watch which makes a smooth movement of a hand, comprising: an accumulating means for accumulating rotational energy of an actuator which is intermittently driven; and a control means

for continuously releasing the rotational energy accumulated in the accumulating means, wherein the accumulating means and the control means are coaxially constructed and disposed apart from the central spindle mounted with a hand.

Specific embodiments of the invention are claimed in the dependent claims.

Other objects and advantages of the invention will become apparent during the following discussion in conjunction with the accompanying drawings, in which:

Fig. 1 is a sectional view of a wheel train unit, illustrating a first embodiment of an electronic watch according to the present invention;

Fig. 2 is a sectional view showing a second embodiment of the electronic watch of the invention; Fig. 3 and 4 are sectional views each depicting a conventional electronic watch;

Fig. 5 is a sectional view showing a third embodiment of the electronic watch of the invention;

Fig. 6 is a sectional view depicting a fourth embodiment of the electronic watch of the invention; Fig. 7 is a conceptual diagram showing an embodiment of an accumulating means incorporated in the electronic watch of the invention;

Fig. 8 is a characteristic diagram of the accumulating means depicted in Fig. 7;

Fig. 9 is a graphic chart showing an example of characteristics in the case of employing a hair spring as the accumulating means of the electronic watch of the invention;

Fig. 10 is a sectional view showing a fifth embodiment of the electronic watch of the invention;

Fig. 11 is a sectional view illustrating a sixth embodiment of the electronic watch of the invention; and

Fig. 12 is a plan view illustrating an electronic watch according to the invention.

Turning first to Fig. 1, there is illustrated a sectional view of a wheel train unit in a first embodiment of an electronic watch according to the present invention. Fig. 12 is a plan view depicting the entire mechanism including the wheel train unit of Fig. 1. An accumulating means functions to accumulate rotational energy in the form of elastic deformation of a hair spring 10 by elastically connecting a hair wheel 9 and a viscous rotor 14 through hair spring 10. A control means behaves to control a rotational velocity by utilizing a viscous resistance of a viscous fluid 17 in which the viscous rotor 14 is immersed within a fluid container 19 mounted on a base plate 21. An actuator involves a step motor composed of a coil 1, a magnetic core 2, a stator 4 and a rotor 5. Coil 1 causes a magnetic field for driving rotor 5 through magnetic core 2 and stator 4. Rotor 5 drives hair wheel 9 through a sixth pinion 6, a fifth wheel 7 and a fifth pinion 8. A hair pinion 11 serves to drive a fourth wheel 15 through an idler 12. Hair pinion 11 and viscous rotor 14 are fixed

to a viscous spindle 13, while hair wheel 9 is rotatable about viscous spindle 13. Fifth wheel 15 is fixed to a second hand spindle 3 integral with a fourth pinion 41, thereby driving a second hand 16. Fourth pinion 41 in turn drives, through a third wheel 25, a minute hand spindle 40 fitted with a minute hand 38 and a second wheel 39. Minute hand spindle 40 is disposed at the center of base plate 21, thus serving as a central spindle. The reference numeral 22 designates a wheel train receiver, disposed vis-à-vis with base plate 21, for retaining the wheel train. The numeral 23 denotes a minute wheel for driving an hour hand; 24 represents a small iron wheel meshing with a sliding pinion 37 by the action of a setting lever 31 and a gate bar 30 when operating a winding stem 32. The hour and minute hands can thus be adjusted. The numeral 33 stands for an IC having a timer circuit; and 35 indicates an oscillator quartz crystal. IC 33 and quartz crystal 35 cooperate to supply coil 1 via a circuit substrate 34 with driving signals for moving rotor 5 of the step motor. The numeral 36 denotes a battery.

Fig. 2 is a sectional view showing a second embodiment of the electronic watch in accordance with the present invention. In this case container 19 is integrally formed with the base plate 21. Fifth wheel 7 serves to drive hair pinion 11, and viscous fluid 17 is present between hair wheel 9 and the surrounding walls of container 19, whereby hair wheel 9 is smoothly moved. Second hand 16 is then driven through fourth wheel 15. Note that hair pinion 11 is rotatable about viscous spindle 13 fixed to hair wheel 9, and hair pinion 11 is linked through hair spring 10 to hair wheel 9. This structure permits the integrality of the viscous rotor with the hair wheel, which, in turn, causes a drop in cost.

Referring to Fig. 5, there is shown a sectional view of a third embodiment of the electronic watch of the invention. A hair spring 10 connected to hair pinion 11 is provided inwardly of hair wheel 9. Viscous fluid 17 is, after being supplied, sealed with a cap 18. Viscous fluid 17 is stagnant in a gap defined by cap 18, hair pinion 11 and hair wheel 9 by dint of the surface tension. In this configuration, the force is imparted from hair wheel 9 via hair spring 10 to hair pinion 11. However, the deformation of hair spring 10 is so regulated by the viscous resistance of viscous fluid 17 as to provide a gradual deformation, and it follows that the hair pinion continuously rotates. Based on this kind of structure, the electric current consumed can readily be reduced, because there is no loss of step motor energy between the base plate and the motor itself due to the viscous load.

Fig. 6 is a sectional view illustrating a fourth embodiment of the electronic watch of the invention. Fifth wheel 7 intermittently drives hair pinion 11, with the result that the hair wheel is smoothly driven through hair spring 10 immersed in viscous fluid 17. In accordance with such an arrangement only hair pinion 11 is inter-

mittently rotated, and the inertia moment of the intermittently movable member can be reduced, resulting in a drop in consumption of electric currents.

Fig. 9 is a graphic chart showing an example of characteristics of the restoring torque and the winding angles of a hair spring. When the winding angle increases due to angular deviation between hair pinion 11 and hair wheel 9, the restoring torque increments almost proportionally. On the other hand, the viscous load associated with the viscous fluid is proportional to a rotational velocity, and hence the rotation is given in a state where the viscous load is equilibrated with the restoring torque.

Fig. 7 is a conceptual diagram depicting another example of the accumulating means incorporated in the electronic watch of the invention, wherein the magnetic attraction or repulsion of a pair of magnetic elements is utilized. The symbol 10a represents a driving magnet, and 10b denotes a driven magnet. The symbols 10c and 10d indicate magnetizing boundaries between N and S pole. In this configuration, when causing angular deviation Θ , the restoring torque, as illustrated in Fig. 8, varies in the form of a sine wave. Hence, if the load torque of the control means is set so that the angular deviation does not exceed 180° , the same utilization as with the hair spring can be attained.

Fig. 10 is a sectional view showing a fifth embodiment of the electronic watch of the invention, wherein driving magnet 10a and driven magnet 10b are provided instead of a hair spring employed in the example of Fig. 1. With this arrangement, there is no necessity for handling an easy-to-deform hair spring. Furthermore, the magnets can be magnetized after having been assembled in the watch movement. This makes the assembly of the watch movement substantially easier since it is not influenced by magnetic forces.

Fig. 11 is a sectional view illustrating a sixth embodiment of the electronic watch of the invention. Driving magnet 10a and driven magnet 10b are disposed in the axial direction, which arrangement prevents a leakage of magnetic field by equalizing the magnitudes of magnets. Consequently, bad influences on the step motor can be prevented.

Six kinds of embodiments of the electronic watch according to the present invention have so far been discussed in detail. The essential arrangement of the present invention is that the accumulating means and control means are coaxially constructed and disposed apart from the center of the watch body. Therefore, the present invention is not limited to those examples. For instance, the actuator may be a piezoelectric element which makes reciprocatory motions or may be an ultrasonic motor. As a matter of course, the control means not only involves the use of the viscous fluid but includes a velocity adjusting unit such as an electromagnetic brake or an escapement.

As discussed above, the present invention exhib-

its remarkably significant and tremendous effects as follows. The accumulating means and the control means are coaxially constructed and disposed apart from the center of watch body. This arrangement leads to decreases in the number of components, in size and in cost, and further facilitates the thinning of the watch.

Although the illustrative embodiments of the present invention have been described in greater detail with reference to the accompanying drawings, it is to be understood that the invention is not limited to those precise embodiment. Various changes or modifications may be effected therein by one skilled in the art without departing from the scope or spirit of the invention.

Claims

1. An electronic watch which makes a smooth movement of a hand, comprising:
 - an accumulating means (10; 10a, 10b) for accumulating rotational energy of an actuator (1, 2, 5) which is intermittently driven; and
 - a control means (14, 17) for continuously releasing the rotational energy accumulated in said accumulating means, **characterized** in that said accumulating means and said control means are coaxially constructed and disposed apart from a central spindle (3) fitted with a hand.
2. The electronic watch as set forth in Claim 1, wherein said control means is composed of a rotor (14) immersed in a viscous fluid (17).
3. The electronic watch as set forth in Claim 1 or 2, wherein said accumulating means is composed of a hair spring (10).
4. The electronic watch as set forth in Claim 1 or 2, wherein said accumulating means is composed of a pair of permanent magnets (10a, 10b) arranged in a face-to-face manner.
5. The electronic watch as set forth in Claim 3, wherein said hair spring (10) is immersed in said viscous fluid (17).
6. The electronic watch as set forth in Claim 3, wherein said hair spring (10) is connected to a rotor (14) immersed in said viscous fluid (17).
7. The electronic watch as set forth in Claim 4, wherein one (10b) of said permanent magnets (10a, 10b) is connected to a rotor (14) immersed in said viscous fluid (17).

Patentansprüche

1. Elektronische Uhr mit einem stetig bewegten Zeiger, umfassend:
 - eine Speicheranordnung (10; 10a, 10b) zur Speicherung der Rotationsenergie eines Aktuators (1, 2, 5), der intermittierend angetrieben wird; und
 - Steuermittel (14, 17) zur kontinuierlichen Freigabe der in der Speicheranordnung gespeicherten Rotationsenergie, dadurch **gekennzeichnet**, daß die Speicheranordnung und die Steuermittel koaxial aufgebaut sind und entfernt von einer mit einem Zeiger versehenen zentralen Welle (3) angeordnet sind.
2. Elektronische Uhr gemäß Anspruch 1, bei der die Steuermittel einen in ein zähflüssiges Fluid (17) eintauchten Rotor (14) umfassen.
3. Elektronische Uhr gemäß Anspruch 1 oder 2, bei der die Speicheranordnung eine Unruhfeder (10) umfaßt.
4. Elektronische Uhr gemäß Anspruch 1 oder 2, bei der die Speicheranordnung ein Paar von Dauermagneten (10a, 10b) umfaßt, die einander gegenüberliegend angeordnet sind.
5. Elektronische Uhr gemäß Anspruch 3, bei der die Unruhfeder (10) in das zähflüssige Fluid (17) eingetaucht ist.
6. Elektronische Uhr gemäß Anspruch 3, bei der die Unruhfeder (10) mit einem in das zähflüssige Fluid (17) eingetauchten Rotor (14) verbunden ist.
7. Elektronische Uhr gemäß Anspruch 4, bei der einer (10b) der Dauermagneten (10a, 10b) mit einem in das zähflüssige Fluid (17) eingetauchten Rotor (14) verbunden ist.

Revendications

1. Une montre électronique qui assure un mouvement progressif d'une aiguille, comprenant :
 - des moyens d'accumulation (10 ; 10a, 10b) destinés à accumuler de l'énergie de rotation d'un actionneur (1, 2, 5) qui est entraîné de façon intermittente ; et
 - des moyens de commande (14, 17) destinés à libérer de manière continue l'énergie de rotation qui est accumulée dans les moyens d'accumulation, caractérisée en ce que les moyens d'accumulation et les moyens de commande sont réalisés de manière coaxiale et sont disposés à distance d'un axe central (3) sur

lequel est montée une aiguille.

2. La montre électronique selon la revendication 1, dans laquelle les moyens de commande sont constitués par un rotor (14) immergé dans un fluide visqueux (17). 5
3. La montre électronique selon la revendication 1 ou 2, dans laquelle les moyens d'accumulation sont constitués par un ressort de balancier (10). 10
4. La montre électronique selon la revendication 1 ou 2, dans laquelle les moyens d'accumulation sont constitués par une paire d'aimants permanents (10a, 10b) placés face à face. 15
5. La montre électronique selon la revendication 3, dans laquelle le ressort de balancier (10) est immergé dans le fluide visqueux (17). 20
6. La montre électronique selon la revendication 3, dans laquelle le ressort de balancier (10) est accouplé à un rotor (14) qui est immergé dans le fluide visqueux (17). 25
7. La montre électronique selon la revendication 4, dans laquelle l'un (10b) des aimants permanents (10a, 10b) est accouplé à un rotor (14) qui est immergé dans le fluide visqueux (17). 30

35

40

45

50

55

5

Fig. 1

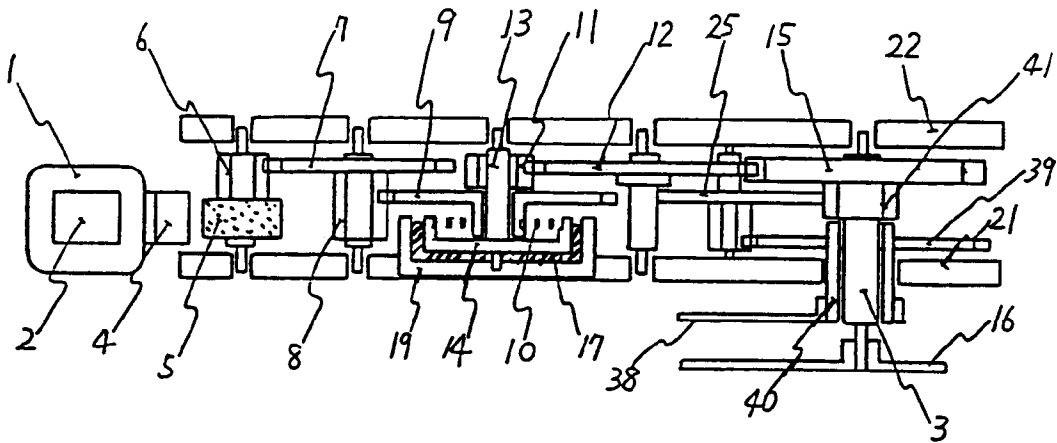

Fig. 2

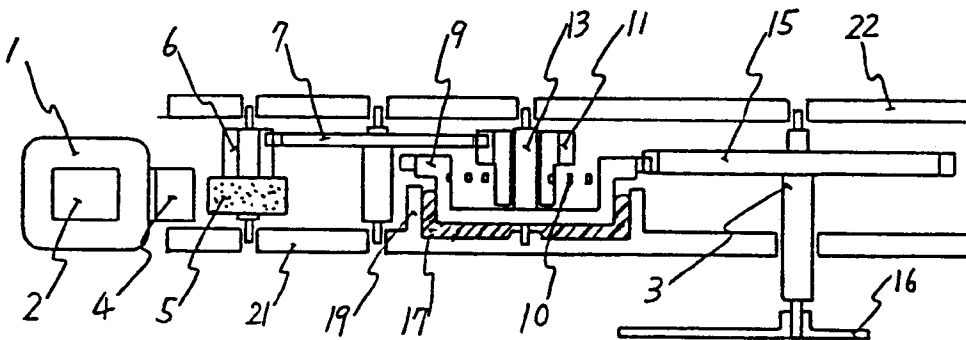

Fig. 3

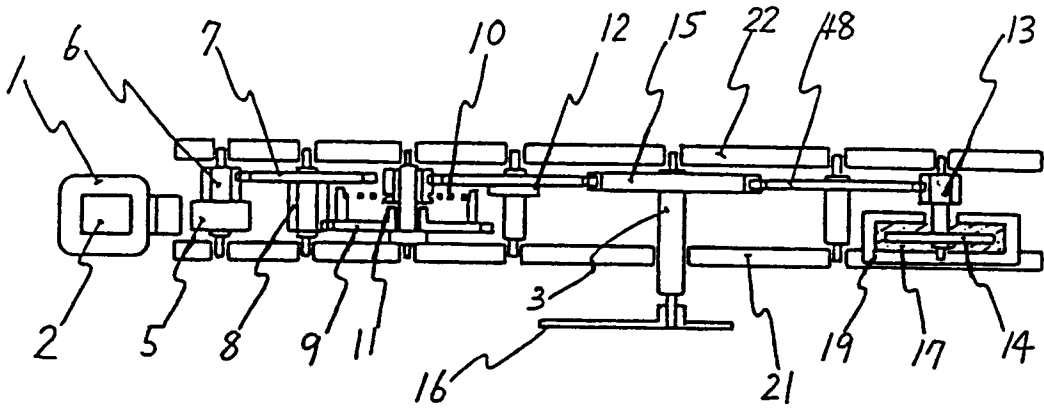

Fig. 4

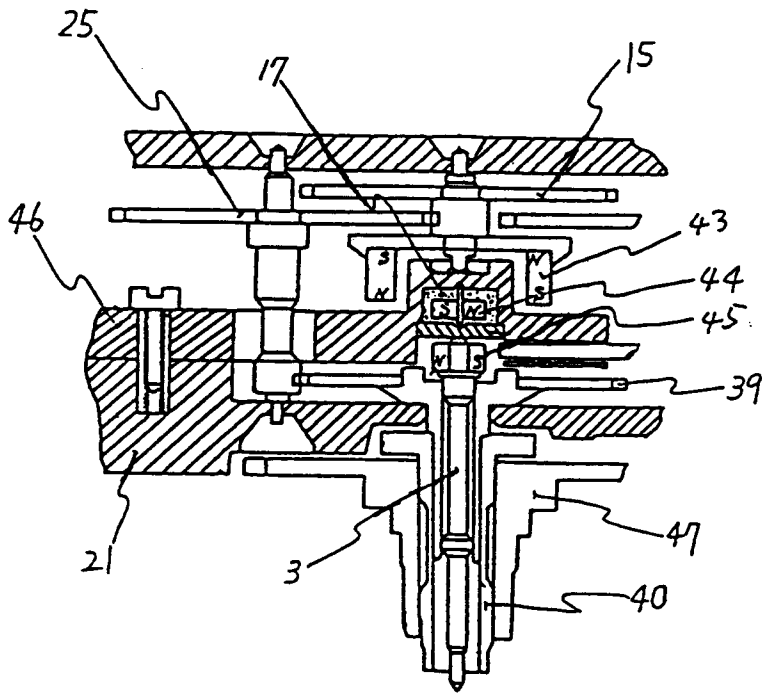

Fig. 5

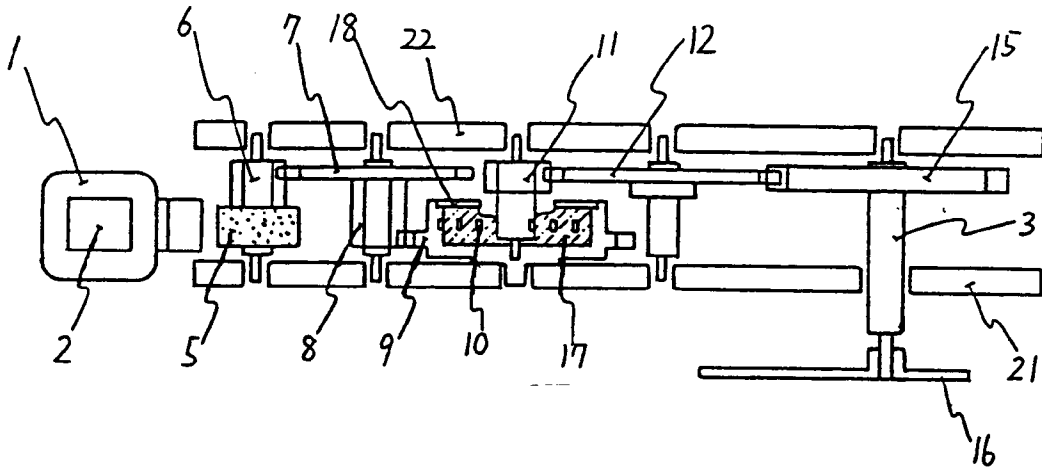

Fig. 6

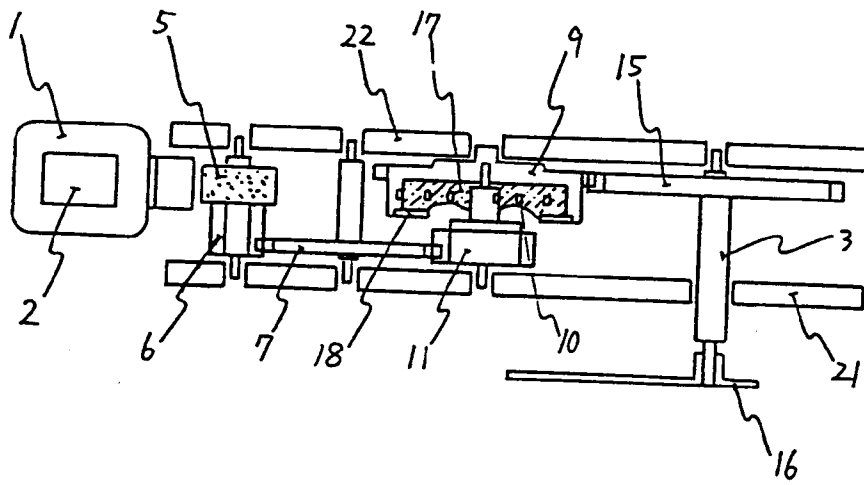

Fig. 7

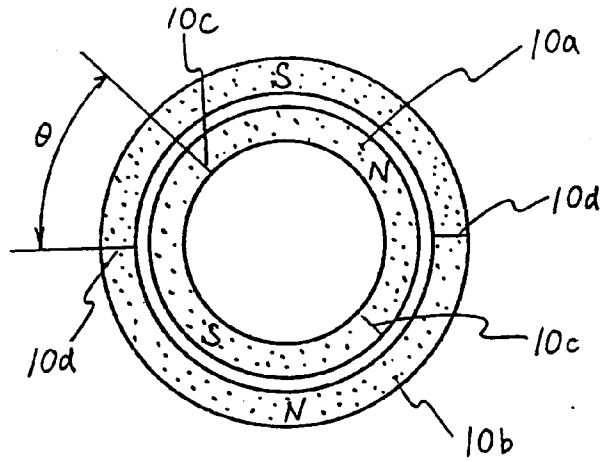

Fig. 8

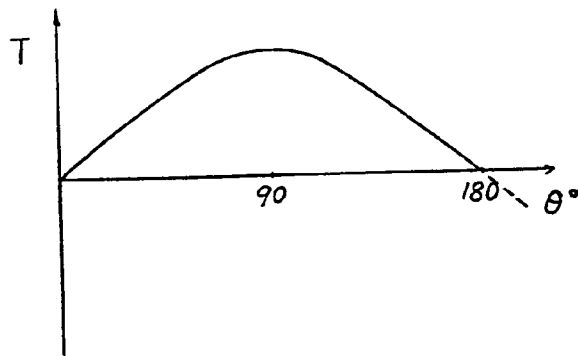

Fig. 9

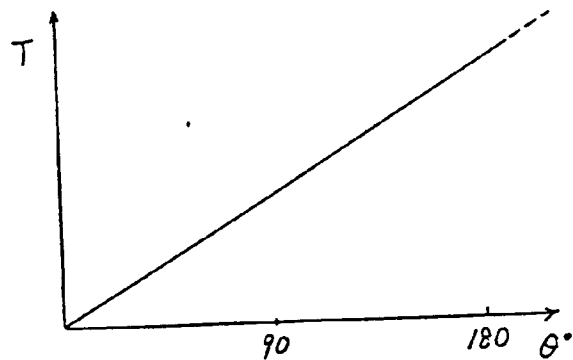

Fig. 10

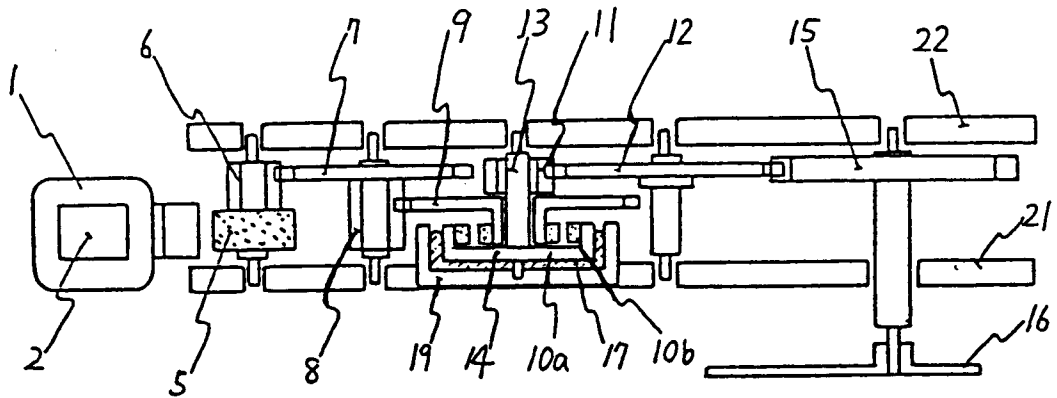

Fig. 11

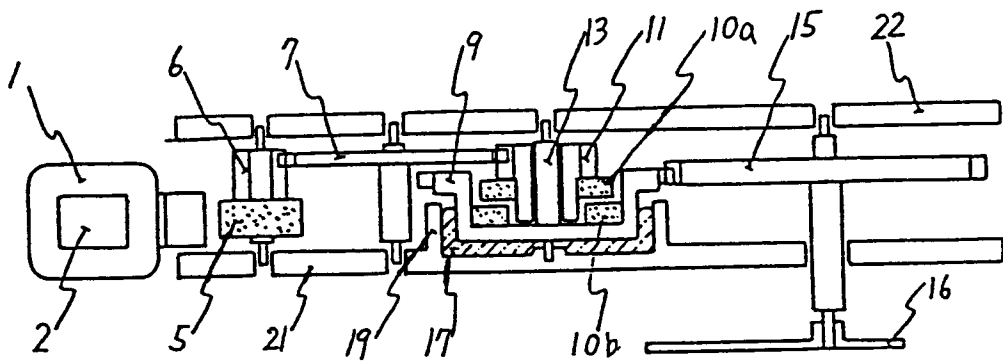

Fig. 12

