

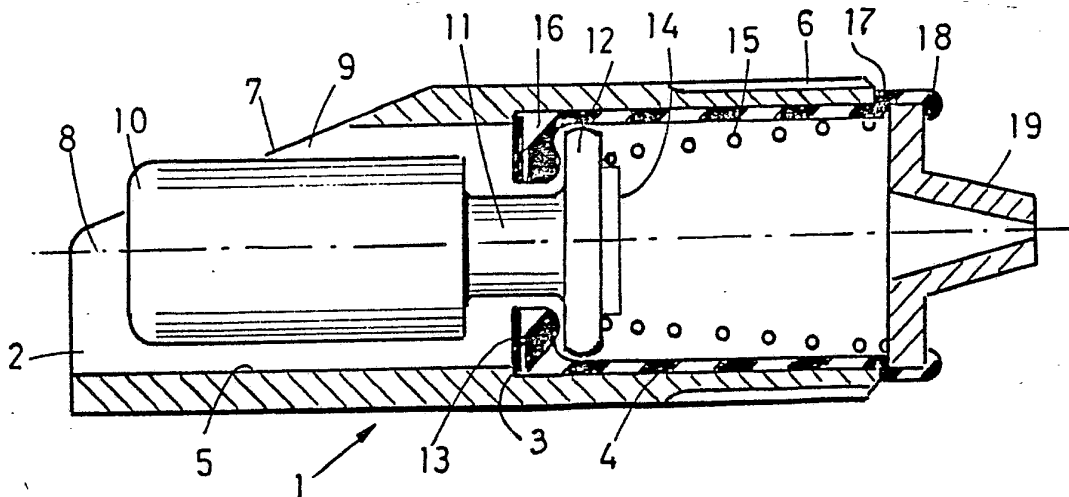

INTERNATIONAL APPLICATION PUBLISHED UNDER THE PATENT COOPERATION TREATY (PCT)

<p>(51) International Patent Classification³ : A01K 7/06; F16K 21/04</p>	<p>A1</p>	<p>(11) International Publication Number: WO 83/02876 (43) International Publication Date: 1 September 1983 (01.09.83)</p>
<p>(21) International Application Number: PCT/SE83/00057 (22) International Filing Date: 21 February 1983 (21.02.83) (31) Priority Application Numbers: 8201157-8 8201158-6 (32) Priority Dates: 24 February 1982 (24.02.82) 24 February 1982 (24.02.82) (33) Priority Country: SE (71) Applicant (for all designated States except US): OLDE, Järn, Rune [SE/SE]; Laduvägen 4, S-752 47 Uppsala (SE). (72) Inventor; and (75) Inventor/Applicant (for US only) : Åkerfeldt, Dan [SE/SE]; Nyvla Gård, S-766 90 Uppsala (SE). (74) Agents: BJELLMAN, Lennart; Dr Ludwig Brann Patentbyrå AB, Drottninggatan 7, Box 1344, S-751 43 Uppsala (SE) et al.</p>		<p>(81) Designated States: AT (European patent), BE (European patent), CH (European patent), DE (European patent), DK, FR (European patent), GB (European patent), JP, NL (European patent), SE (European patent), US. Published <i>With international search report.</i> <i>In English translation (filed in Swedish).</i></p>

(54) Title: ANIMAL WATERING DEVICE



(57) Abstract

Animal watering device which is constituted by a tubular housing (1) having a through-bore (2). This bore is divided into two portions, a valve portion (4) and an outlet portion (5). A valve mechanism (11, 12, 13) is located within the valve portion (4) and allows opening and closing of the liquid flow through the watering device. An operating means (10) for the operation of the valve mechanism (11, 12, 13) is accessible for actuation by the drinking animal. The valve mechanism includes a tubular insert (17) of flexible material through which the valve stem (11) at least partially extends and integral therewith it includes on one hand the valve seat (16) and on the other hand a skirt extending around the periphery of the valve plate (12). Mounted within the valve portion (4) the insert (17) rests against a support (3) separating the valve portion (4) from the outlet portion (5).

FOR THE PURPOSES OF INFORMATION ONLY

Codes used to identify States party to the PCT on the front pages of pamphlets publishing international applications under the PCT.

AT	Austria	LI	Liechtenstein
AU	Australia	LK	Sri Lanka
BE	Belgium	LU	Luxembourg
BR	Brazil	MC	Monaco
CF	Central African Republic	MG	Madagascar
CG	Congo	MR	Mauritania
CH	Switzerland	MW	Malawi
CM	Cameroon	NL	Netherlands
DE	Germany, Federal Republic of	NO	Norway
DK	Denmark	RO	Romania
FI	Finland	SE	Sweden
FR	France	SN	Senegal
GA	Gabon	SU	Soviet Union
GB	United Kingdom	TD	Chad
HU	Hungary	TG	Togo
JP	Japan	US	United States of America
KP	Democratic People's Republic of Korea		

Animal Watering Device

The present invention relates to liquid dispensing devices and more precisely to animal watering devices in which the liquid dispensing to a drinking animal takes place by that the animal itself actuates some type of operating means opening and
5 closing a valve.

The valve mechanism in such dispensing devices comprises a valve cone or plate sealing against circular valve seat through which a valve stem from the valve cone or plate extends. The
10 valve is opened when the cone or plate is forced from the seat or tilted in relation thereto and returns to closing position by the aid of a spring and/or the pressure of the liquid as soon as the actuation by the animal ceases.

15 One example of such a watering device including such a valve mechanism is what is called a bite valve and is clear from Swedish specification Ser.No. 354.565. The watering device shown in said specification comprises a tubular housing one end of which is provided with an external mounting thread and
20 the other end of which being intended to be brought into the mouth of a drinking animal. The dispensing end of the housing is bevelled or has a cut-away portion from a plane through the axis of the tube and backwards and upwards. In the opening shaped thereby, which seen from above is in the shape of a
25 half-ellipse, an operating means is accessible which a drinking animal is pressing against the underlying portion of the housing for opening the valve for the liquid through-flow.

The present type of watering devices is well known and widely
30 used. However, it shows the drawback that it is expensive to manufacture due to the fact that it consists of many parts which are to be manufactured and mounted together and some of said parts are of such a shape that they request complicated manufacturing operations. Also the bore through the tubular



valve housing must be given a rather extensive working so that the necessary shoulders and grooves are obtained. A result thereof is also the fact that the watering device is difficult to renovate.

5

An attempt to produce a cheaper watering device has i.a. given rise to the fact that the operating means has been given the shape of a narrow pin or stem. Further to the fact that such an operating means in unfortunate cases may be subjected to deformation, it must be regarded as unsuitable from the anatomical point of view. Although the force with which the drinking animal has to depress the operating means not is particularly great there is in spite of this fact a marked contact from the operating means the mouth of the drinking animal which contact is sufficient to give rise to discomfort and in some cases gall-sores.

10
15

The problem of the more solid operating means or nipple relates more to the manufacturing thereof as the annular valve seat is to be located between the operating means and the valve plate, around the valve stem extended therebetween. As the valve seat normally is constituted by a shoulder in the housing of the watering device it has been necessary to have either the operating portion or the valve plate possible to remove from the valve stem in order to make assembling possible. The housing has also contained other shoulders for restrictions, screens and similar. Such an embodiment has also involved many working operations for the manufacturing of the housing and of course also for the operating means including valve parts, as well as for the mounting of the many parts.

20
25
30

Accordingly, a desire has been to make it possible to manufacture operating means, valve stem and valve plate or cone in one piece.

35

When the valve mechanism includes a valve plate normally



occupying a vertical position and which is depressed by the repeated tilting of the valve stem for opening of the valve, it occurs that the lower edge of the valve plate wears into the valve housing. This does not mean that the valve starts to
5 leak but it is getting more and more difficult to open to a sufficient degree due to the fact that the distance between the operating means and the underlying portion of the tubular housing is so small that when depressing the operating means the tilting of the plate is insufficient for a satisfactory
10 opening of the valve in order to give a satisfactory water flow therethrough.

The object of the present invention is to remove the above problems. This object is reached by a structure of the type
15 referred to in the claims from which also the particularly characterizing features of the invention are clear.

The invention is more closely described in the following with reference to the attached drawings, in which
20

FIG. 1 is a longitudinal section through one embodiment of a watering device in accordance with the invention,

FIG. 2 is a longitudinal section through a second embodiment
25 of the watering device in accordance with the invention, and

FIG. 3 is a longitudinal section through a third embodiment of the watering device in accordance with the invention.

30 The embodiments of the watering device in accordance with the invention shown in the drawings include a tubular housing 1 the bore 2 therethrough by a shoulder 3 being divided into two portions, a valve portion 4 and an outlet portion 5, the diameter of the outlet portion 5 being slightly less than that
35 of the valve portion 4. Valve portion 4 is provided with an external thread 6 for mounting of the watering device 1 to

e.g. a water supply conduit in a conventional way. The outlet portion 5 is bevelled or angle-cut at 7 from a plane through the axis 8 of the tubular housing 1 and backwards and upwards so that an opening 9 is formed which from above looks like a half-ellipse.

As an alternative the shoulder may be manufactured in such a way that it is rolled into the housing 1 and will then be constituted by an annular ridge. In such a case the valve portion 4 and the outlet portion 5 are of the same diameter. The shoulder may also be constituted by a resilient ring which is mounted into a groove cut in the internal wall of the housing.

There is an operating means or nipple 10 in the outlet portion 5 and this is of a slightly less diameter than the internal diameter of the outlet portion 5. The operating means 10 extends from a position inside the opening 9 and nearly up to the outer end of the outlet portion 5. Thereby, a portion of the operating means 10 will be exposed in the opening 9 so that an animal opening its mouth over the watering device will be able to depress the operating means 10 for opening the flow-path through the watering device. Due to this solid operating means 10 as well as its protected location a drinking animal can neither hurt itself nor give rise to any deformation of the operating means and the valve mechanism belonging thereto.

From the operating means or nipple 10 there is extended a valve stem 11 to a valve plate 12 the diameter of which being the same or slightly greater than the one of the operating means 10. A washer 13 extended around the stem 11 is resting against the shoulder 3 and preventing the valve mechanism from sliding through the bore 2. Valve plate 12 is provided with a protrusion 14 constituting a guide for a spring 15 biasing the valve plate 12 against its seat 16 in turn kept in place by



the washer 13.

In the embodiment shown in Fig. 1 a hose-like insert 17 is brought into the valve portion 4 of the tubular housing 1. In this connection the valve seat 16 is constituted by a bead at the inner end of the insert 17. At its outer end the insert 17 is provided with a similar bead 18 gripping around the edge of a restriction 19 and keeping it in place. Spring 15 is clamped between restriction 19 and valve plate 12 and is pressing the valve plate 12 against the valve seat 16.

The housing 1 as well as the operating means 10 together with the stem 11 and the valve plate 12 are preferably made of metal such as stainless steel or brass but also some wear resistant plastic is conceivable. The operating means 10, the stem 11 and the valve plate 12 with the protrusion 14 are in this embodiment made of one and the same piece which results in a very simple manufacturing of this detail.

The insert 17 is made of a flexible material such as natural or synthetic rubber or plastic.

The assembly of the watering device is very simple. The washer 13 which is split and of resilient material is bent open and thread over the valve stem 11 and is thereafter due to its resiliency allowed to return to its original shape. The bead-shaped valve seat 16 of the insert 17 is stretched over valve plate 12 to the position between the plate and the washer 13. Thereafter, the insert 17 together with thereto assembled parts is brought into the valve portion 4 to the position in which washer 13 rests against shoulder 3. In this position spring 15 is inserted into abutment against the valve plate 12 and is clamped between the plate and the restriction 19 which is locked in place by the fact that the bead 18 of the insert 17 is stretched over its edge. It is also possible to carry out the whole assembly of the parts within the insert before

it is brought into the valve portion 4 of the housing 1.

The embodiment of the invention shown in Fig. 2 differs from the one in accordance with Fig. 1 by the fact that the
5 restriction 19' constitutes a portion of the insert 17'. In this embodiment the mounting has to take place in such a way that first spring 15' is inserted in the insert 17 before the bead-shaped valve seat 16' is stretched over the valve plate 12. Therebefore, washer 13 should preferably have been
10 mounted onto the valve stem 11. Thereafter, the insert 17' in the way mentioned is brought into the valve portion 4 of the housing 1.

In the embodiment in accordance with Fig. 2 insert 17' may be
15 made of a slightly harder material. Then, in order to get the valve plate 12 mounted in the insert, the insert may be completely or to some extent split whereby the insert can be widened sufficiently to allow plate 12 to be brought in place. Thereafter, the slit is sealed by glue or tape. In this
20 connection the valve seat is preferably constituted by an O-ring which can be stretched over the valve plate in order to get in place.

Of course, both the shown embodiments of the watering device
25 in accordance with the invention can be made of stiff material and even if this should be so stiff that cutting and bending apart of the insert 17, 17' in order to get the valve plate 12 in place not should be possible but this had to be mounted in some other way, e.g. by screwing as previously mentioned an
30 essential saving of work and parts is made in comparison with the watering devices mentioned in the preamble due to the fact that the valve portion of the watering device is located in a simple insert which is easy to mount and to replace.

35 In such an embodiment it would not be necessary to have any shoulder 3 in the housing 1 itself but this could then be made



of a pipe of a suitable material such as stainless steel or brass, which pipe then only had to be cut into suitable lengths each length in turn being subjected to an outer treatment to desired shape of the drinking portion and cutting
5 of a mounting thread. In such a case the valve insert 17, 17' is sufficiently stiff in order to constitute itself a valve seat support corresponding to washer 13. Such an insert can easily be moulded or injection moulded from plastic material. Indeed, the operating means 10 must in this connection be
10 attachable to the valve stem 11 by e.g. screwing but such increase in the costs are more than well saved by the lower price of the housing 1. Further, such a valve is easy to renovate. In such an embodiment the insert 17, 17' is kept in place by the fact that it at the outer end is provided with
15 some sort of protrusion or bead as shown in the drawings whereby the insert is prevented from passing through the housing 1.

In the embodiment in accordance with Fig. 3 the bead or valve seat 16" constitutes a portion of an insert 17" of flexible
20 material which also extends around the periphery of the valve plate 12 in the shape of a skirt 18". This skirt 18" acts as a guide for the valve plate 12 and prevents the valve plate 12 from wearing into the housing 1 itself for which there is a
25 risk as previously mentioned. However, there must be a sufficient play between the skirt 18" and the periphery of the plate 12 in order to allow a flow of liquid therethrough when the valve is open.

30 Spring 15" is extended between valve plate 12 and a restriction 19" at the inlet to the housing 1 of the watering device and is forcing the valve plate 12 into sealing engagement with the valve seat 16".

35 The insert 17" is made of a stretchable material such as natural or synthetic rubber or plastic.



Also in this embodiment the assembly of the valve mechanism is very simple. Washer 13" which is split and of a resilient material is bent apart and thread over the valve stem 11 whereafter it is allowed to return to its original shape. The
5 bead-shaped valve seat 16" of the insert 17" is stretched over the valve plate 12 to a position between the plate and washer 13", the skirt 18" surrounding the periphery of the plate 12. As the insert 17" is of such a stretchable material that it easily returns to its original shape the valve seat 16" will
10 not be deformed by such an operation.

In order to get the valve mechanism in place in the housing there is used a suitable tool whereby the bead-shaped valve seat 16" will rest correctly against washer 13" which in turn
15 rests against shoulder 3. In this inserted position, spring 15" is located into engagement with the valve plate 12 and is clamped against the restriction 19" which with snap-in action locks into a groove in the outer portion of the valve portion
4.

20

Indeed, the insert 17" could be made from a non-stretchable material. Then the assembly requires that the insert is split and can be stretched out over the valve plate or that stem 11 could be made free from either the valve plate 12 or the
25 operating means 10. Thereafter, the slit has to be sealed by glue or tape and preferably, in such connection an O-ring is used as a valve seat which without deformation can be stretched over the valve plate in order to be brought in place. Although these embodiments might be more expensive than
30 the one to be preferred they are, in spite of this fact, cheaper than the conventional embodiment.

In order to solve the problem mentioned in the preamble which relates to the wearing of the valve plate 12 into the wall of
35 the insert below the plate the opening for the valve stem may



be eccentric. Accordingly, when the watering device is new the axis of the valve stem 11 will be located above the axis 8 of the device but after use during a long time the axes will coincide. In this embodiment the insert is provided with some
5 type of positioner such as a projection matching into a corresponding recess in the housing. By this structure the watering device will then have during all its life a satisfactory water-through flow. For guiding the valve plate 12 and in order to get a reliable flow path around the
10 periphery of the valve plate 12 the portion of the insert 17 surrounding the plate 12 may be provided with inwardly directed ridges which are axially extended and which are forming flow channels therebetween.

15 As is clear from what is stated above, by the present invention an animal watering device has been invented having at least the same good operational characteristics as previously known similar devices. Due to the internal structure thereof the watering device in accordance with the
20 present invention is essentially cheaper both to manufacture and to assemble than the ones previously known simultaneously as the advantage is obtained that it can be renovated without particular equipment.

CLAIMS

1. Animal watering device comprising a tubular housing (1) having a through-bore (2) which bore (2) being divided into two portions, a valve portion (4) and an outlet portion (5), a valve mechanism (11, 12, 13) in the valve portion (4) for opening and closing the liquid flow through the watering device, and an operating means (10) for the operation of the valve mechanism (11, 12, 13) which means being accessible for actuation by the drinking animal, characterized by the fact that the valve mechanism (11, 12, 13) includes a tubular insert (17, 17', 17") of flexible material through which the valve stem (11) at least partially extends, that the insert (17, 17', 17") in one and the same piece includes on one hand the valve seat (16, 16', 16") and on the other hand a skirt extending around the periphery of the valve plate (12), and that the insert (17, 17', 17") rests against a support (3) separating the valve portion (4) from the outlet portion (5).
2. Watering device in accordance with claim 1, characterized by the fact that an annular washer (13) surrounds the valve stem (11) and constitutes a support for the insert (17, 17', 17") and the valve seat (16, 16', 16") against the support (3) separating the valve portion (4) from the outlet portion (5).
3. Watering device in accordance with claim 2, characterized by the fact that the washer (13) is split.
4. Watering device in accordance with claim 1, 2 or 3, characterized by the fact that the support (3) separating the valve portion (4) from the outlet portion (5) is constituted by a shoulder shaped as an annular ridge radially pressed into the housing.
5. Watering device in accordance with any of preceding claims, characterized by the fact that the insert (17, 17', 17") is removably insertable into the valve portion (4) in the housing (1).
6. Watering device in accordance with any of preceding



claims, characterized by the fact that valve plate (12) together with valve stem (11) and operating means (10) are eccentrically located in relation to the axis of the tubular housing (1).

5 7. Watering device in accordance with any of preceding claims, characterized by the fact that the insert (17, 17', 17'') is made by a flexible material such as natural or synthetic rubber.

10 8. Watering device in accordance with any of preceding claims, characterized by the fact that a restriction (19, 19', 19'') for the liquid flow through the watering device is formed integral with the insert (17, 17', 17'').

15 9. Watering device in accordance with any of preceding claims, characterized by the fact that the insert (17, 17', 17'') is removably insertable into the valve portion (4) of the housing (1).



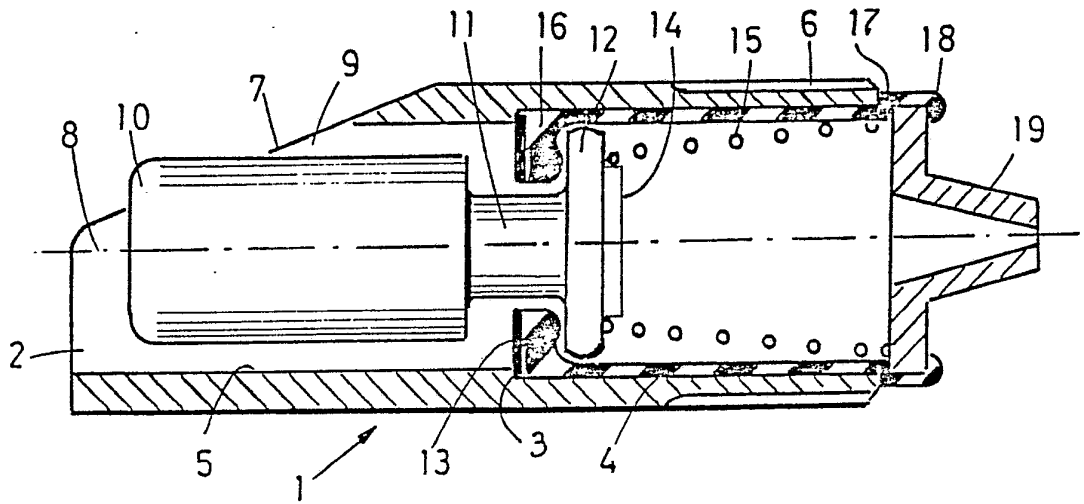

FIG. 1

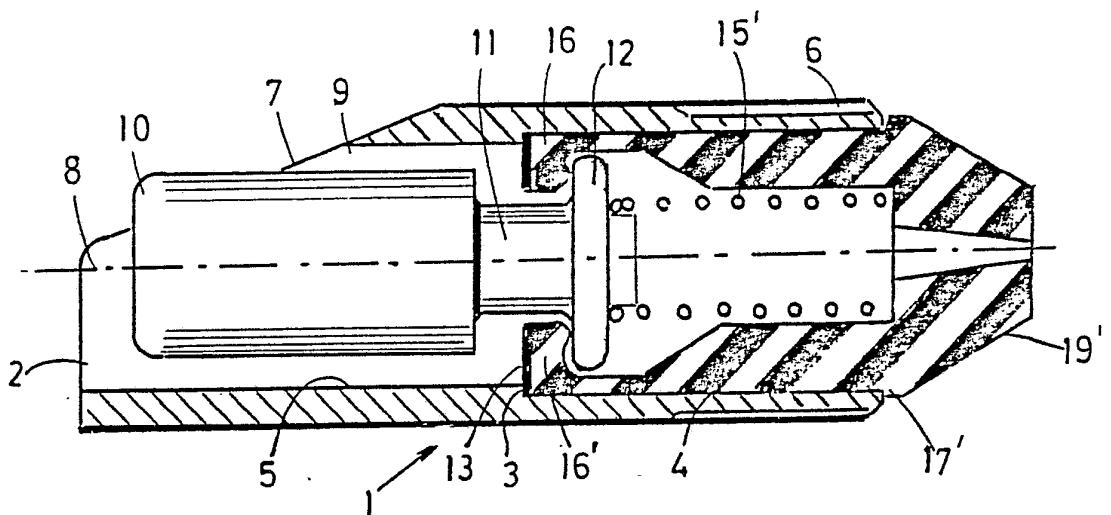

FIG. 2

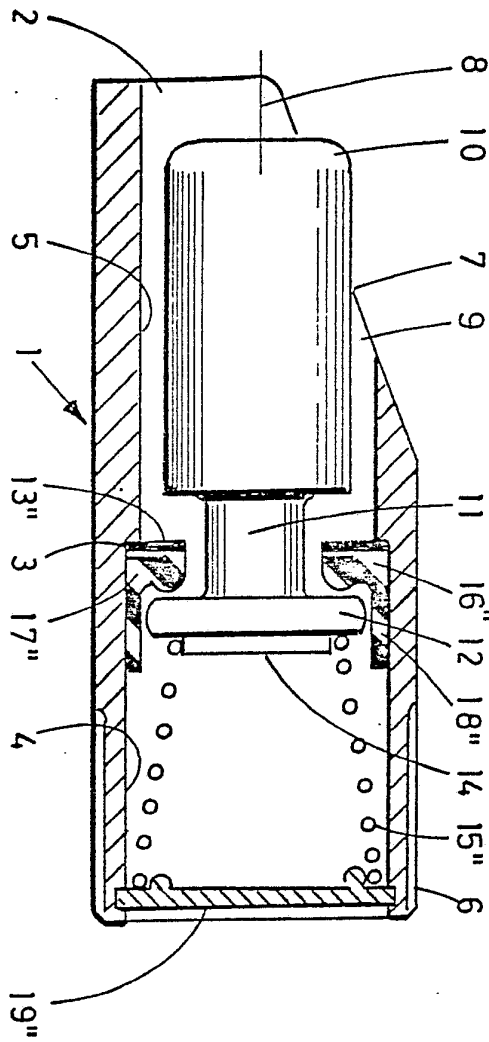



FIG. 3



INTERNATIONAL SEARCH REPORT

International Application No PCT/SE83/00057

I. CLASSIFICATION OF SUBJECT MATTER (If several classification symbols apply, indicate all) ³		
According to International Patent Classification (IPC) or to both National Classification and IPC 3		
A 01 K 7/06, F 16 K 21/04		
II. FIELDS SEARCHED		
Minimum Documentation Searched ⁴		
Classification System	Classification Symbols	
IPC 3	A 01 K 7/00-7/02, 7/06, 39/02, F 16 K 21/04-06	
US CI	119:72-72.5, 75, 251:339	
Documentation Searched other than Minimum Documentation to the Extent that such Documents are Included in the Fields Searched ⁵		
NO, DK, FI, SE classes as above		
III. DOCUMENTS CONSIDERED TO BE RELEVANT ¹⁴		
Category ⁶	Citation of Document , ¹⁶ with indication, where appropriate, of the relevant passages ¹⁷	Relevant to Claim No. ¹⁸
Y	DE, A , 1 500 027 (FARM AUTOMATION LTD) 8 May 1969 (see fig 4 and 5)	6
Y	DE, B , 2 857 700 (SUEVIA HAIGES KG) 13 September 1979	1-9
Y	US, A , 3 008 451 (P N CURRY) 14 November 1961	1, 4-5, 8-9
Y	US, A , 3 716 030 (GODSHALK) 13 February 1973	1, 4-5, 7-9
Y	US, A , 4 006 716 (CROSS) 8 February 1977 & DE, A, 2 647 728 (CROSS) 8 June 1977	1, 4, 5, 7-9
Y	US, A , 4 284 036 (HOSTETLER) 18 August 1981	1-9
<p>⁹ Special categories of cited documents: ¹⁸</p> <p>"A" document defining the general state of the art which is not considered to be of particular relevance</p> <p>"E" earlier document but published on or after the international filing date</p> <p>"L" document which may throw doubts on priority claim(s) or which is cited to establish the publication date of another citation or other special reason (as specified)</p> <p>"O" document referring to an oral disclosure, use, exhibition or other means</p> <p>"P" document published prior to the international filing date but later than the priority date claimed</p> <p>"T" later document published after the international filing date or priority date and not in conflict with the application but cited to understand the principle or theory underlying the invention</p> <p>"X" document of particular relevance; the claimed invention cannot be considered novel or cannot be considered to involve an inventive step</p> <p>"Y" document of particular relevance; the claimed invention cannot be considered to involve an inventive step when the document is combined with one or more other such documents, such combination being obvious to a person skilled in the art.</p> <p>"&" document member of the same patent family</p>		
IV. CERTIFICATION		
Date of the Actual Completion of the International Search ¹⁹	Date of Mailing of this International Search Report ²⁰	
1983-05-10	1983-05-26	
International Searching Authority ²¹	Signature of Authorized Officer ²⁰	
Swedish Patent Office	 Kerstin Eckersten	