

(No Model.)

C. F. BERLIN.
WATCH DEMAGNETIZER.

No. 436,205.

Patented Sept. 9, 1890.

Fig. 1.

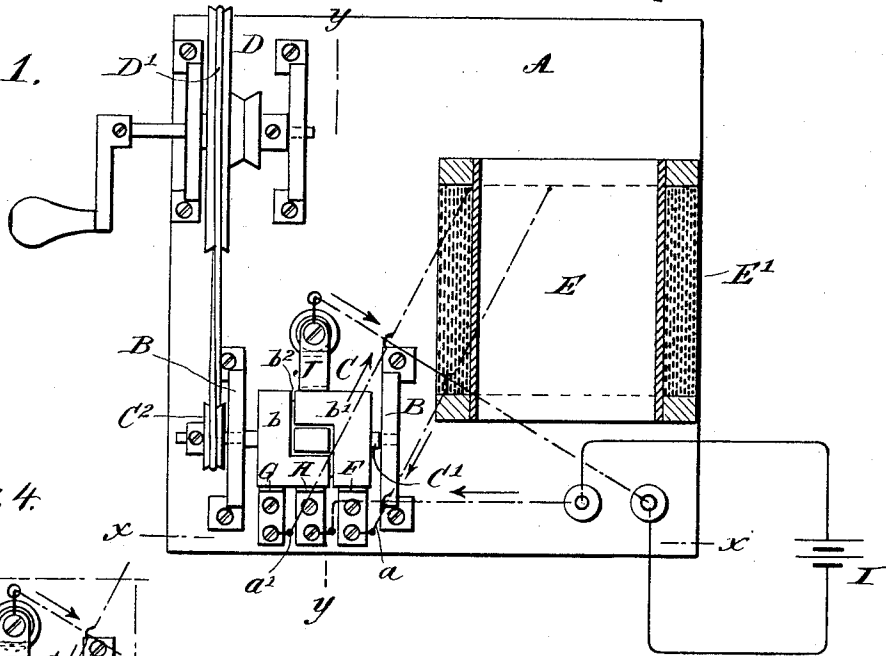

Fig. 4.

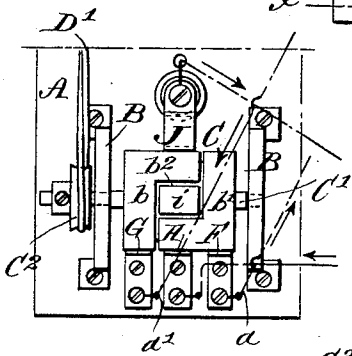

Fig. 2.

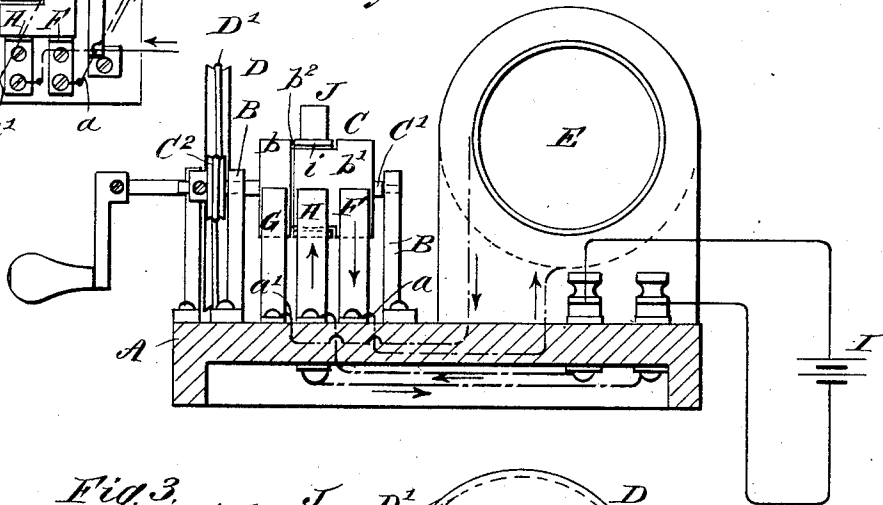
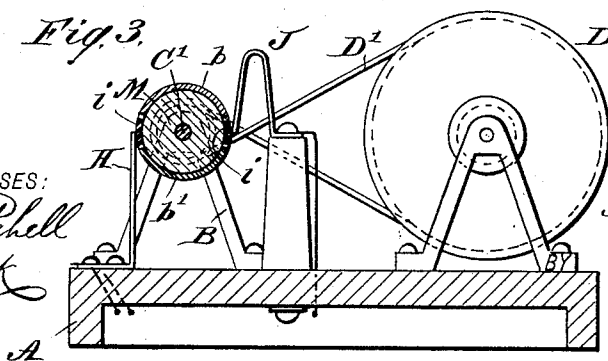

Fig. 3.



WITNESSES:
Dwight Twitchell
Co. Sedgwick

INVENTOR:
C. F. Berlin
Munn & Co.
ATTORNEYS

UNITED STATES PATENT OFFICE.

CHARLES F. BERLIN, OF NEW YORK, N. Y., ASSIGNOR TO ALFRED C. SMITH,
OF SAME PLACE.

WATCH-DEMAGNETIZER.

SPECIFICATION forming part of Letters Patent No. 436,205, dated September 9, 1890.

Application filed January 15, 1890. Serial No. 337,016. (No model.)

To all whom it may concern:

Be it known that I, CHARLES F. BERLIN, of New York, in the county and State of New York, have invented a new and Improved Demagnetizer, of which the following is a full, clear, and exact description.

Reference is to be had to the accompanying drawings, forming a part of this specification, in which similar letters of reference indicate corresponding parts in all the figures.

Figure 1 is a plan view of my new and improved demagnetizer, the demagnetizing-chamber being shown in section. Fig. 2 is a sectional elevation of the same on line *x x* of Fig. 1. Fig. 3 is a similar view on line *y y* of Fig. 1, showing the current-reverser or commutator in neutral position; and Fig. 4 is a partial plan view.

The object of my invention is to provide a practical demagnetizer, designed especially for the use of watch-makers and jewelers for demagnetizing watches and other articles; and the invention consists, principally, in combining with a demagnetizing-chamber composed of or surrounded by a coil of insulated wire, a rheotrope acting in connection with plates or brushes to reverse, in rapid succession, a current of electricity from any source, causing it to alternately pass in opposite directions through the coil.

The invention also consists in the construction, arrangement, and combination of parts, all as hereinafter described and claimed.

On a suitable support A are mounted the uprights B B, in which is journaled the rheotrope C, the shaft C' of which fits in suitable bearings in the said uprights. On one end of the shaft C' is secured a pulley C² for revolving the rheotrope by means of a crank-wheel D and belt D'.

The article to be demagnetized is to be passed through the demagnetizing-chamber E, surrounded by a coil E' of fine insulated wire, one terminal *a* of which is connected to the brush or plate F, the other *a'* with the brush or plate G, both of which plates are in constant contact with the rheotrope, but owing to the space *b²* between the two metal jackets *b b'* are never in electrical connection with each other:

Between the two brushes or plates F G and pressing against the rheotrope is another brush or plate H, which is connected by a wire to one pole of the battery I, and on the opposite side of the rheotrope and pressing against it is still another brush or plate J, connected by a wire to the other pole of the battery, as illustrated clearly in Fig. 1, so that when the rheotrope is revolved the jackets *b b'* thereof, being overlapped at the center, alternately connect the brush or plate J with the plates F G, and thus reverse the electric current.

As illustrated in Fig. 1, the current passes to plate or brush H, through jacket *b* to plate or brush G, thence through the coil E' to plate or brush F, through jacket *b'* to plate or brush G, thence back to the battery.

When the rheotrope is in the position shown in Fig. 2, the current passes to brush H, thence through jacket *b'* to brush F, thence through the coil E' to brush G, and through jacket *b* and brush J back to the battery.

When the rheotrope is in the position shown in Fig. 3, the center brushes H J rest against isolated plates *i i*, which are out of contact with the jackets *b b'*, and rest, like said jackets, on the core M of rubber or other non-conducting material, and thus cut off the current from the coil E'.

In use to demagnetize any article it is only necessary to turn the wheel D by its crank or otherwise, which will rapidly revolve the rheotrope and cause alternate currents to pass through the coil E', as above described, and at the same time pass the watch or other article slowly through the demagnetizing-chamber E.

Any source of electricity may be employed which may be convenient—a battery, an electric-light connection, or other source.

Having thus described my invention, what I claim as new, and desire to secure by Letters Patent, is—

1. A demagnetizer constructed substantially as herein shown and described, the same consisting of a demagnetizing-chamber, a coil of wire surrounding the same, and a rotary rheotrope, combined with four brushes, two connected with the coil of wire surrounding

the demagnetizing-chamber, and two with the battery or source of electricity, substantially as described.

2. A demagnetizer comprising a demag-
5 netizing-chamber, a coil of wire surrounding the same, and a rotary rheotrope having two opposite insulated plates, in combination with four brushes, two connected to the battery

and two to the wire composing the coil, the latter being arranged to come in contact with 10 the opposite insulated plates, substantially as described.

CHARLES F. BERLIN.

Witnesses:

H. A. WEST,
C. SEDGWICK.