

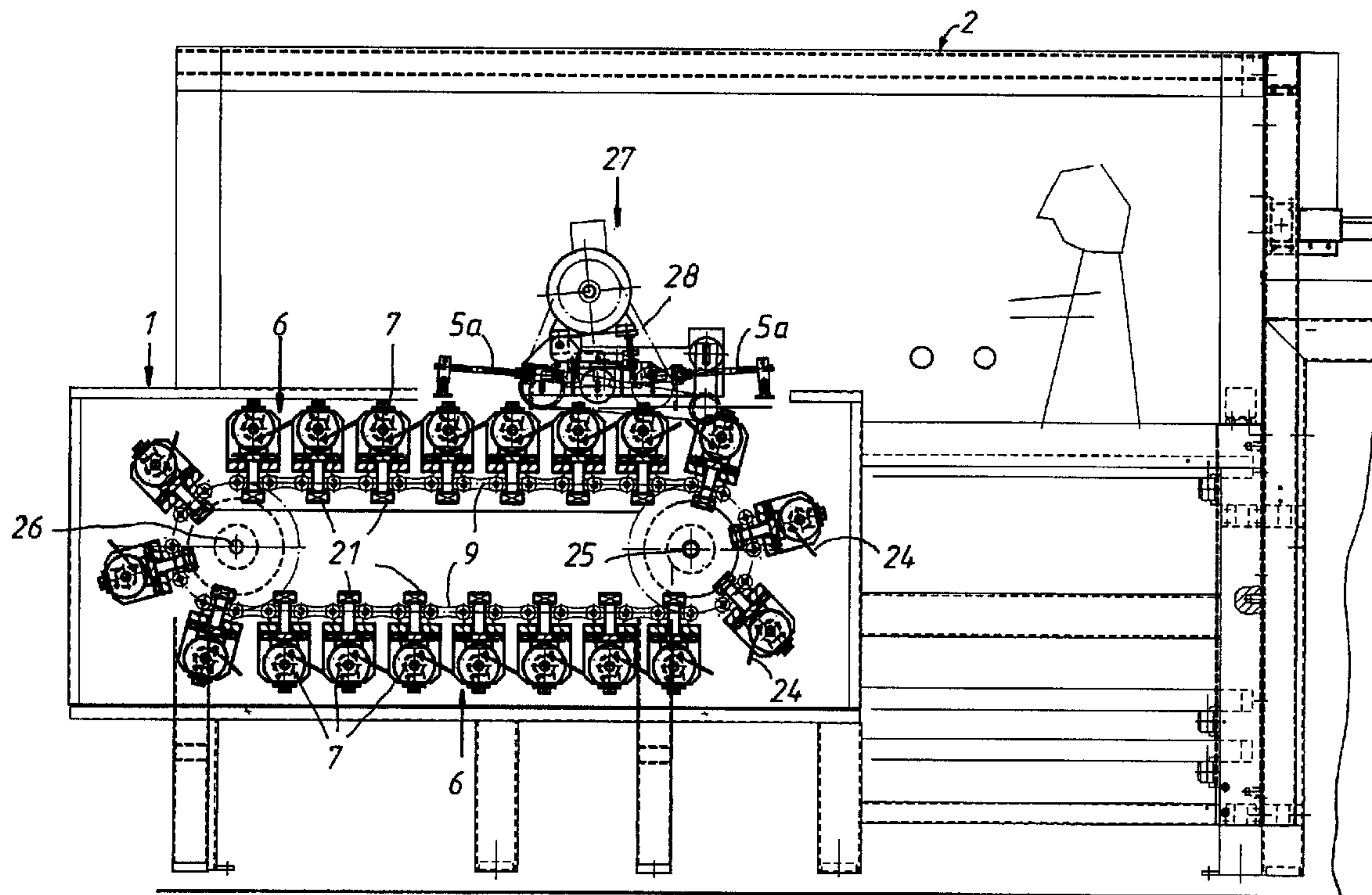

(86) Date de dépôt PCT/PCT Filing Date: 1998/07/23  
 (87) Date publication PCT/PCT Publication Date: 1999/02/04  
 (45) Date de délivrance/Issue Date: 2006/04/11  
 (85) Entrée phase nationale/National Entry: 2000/01/21  
 (86) N° demande PCT/PCT Application No.: AT 1998/000178  
 (87) N° publication PCT/PCT Publication No.: 1999/004639  
 (30) Priorité/Priority: 1997/07/23 (A 1249/97) AT

(51) Cl.Int./Int.Cl. *A21C 15/02* (2006.01)  
 (72) Inventeurs/Inventors:  
 HAAS, FRANZ SEN, AT;  
 HAAS, JOHANN, AT;  
 OBERMAIER, FRITZ, AT  
 (73) Propriétaire/Owner:  
 FRANZ HAAS WAFFELMASCHINEN-INDUSTRIE  
 AKTIENGESELLSCHAFT, AT  
 (74) Agent: FETHERSTONHAUGH & CO.

(54) Titre : MACHINE POUR FORMER DES CORNETS  
 (54) Title: MACHINE FOR FORMING CONES



(57) Abrégé/Abstract:

The invention relates to a machine (1) for forming rolled-up wafer cones from individual, baked, substantially flat wafer cakes. Several rolls (7) are juxtaposed in a stationary machine housing, along a closed circumferential path. At each roll, a wafer cake, in the form of a hot plastically deformable material, is rolled up between a die (23) and a punch (14) to form a cone, while the rolls (7) move, turning along their path, from the input station to the output station of the cone forming machine. An endless chain (6) of rolls extends along the circumferential path, each roll providing a support frame (8) which supports a punch (14) and a die (23). This support frame is secured to two endless conveyor chains extending parallel to each other, along the circumferential path.



**PCT**  
WELTORGANISATION FÜR GEISTIGES EIGENTUM  
Internationales Büro  
INTERNATIONALE ANMELDUNG VERÖFFENTLICHT NACH DEM VERTRAG ÜBER DIE  
INTERNATIONALE ZUSAMMENARBEIT AUF DEM GEBIET DES PATENTWESENS (PCT)

<p>(51) Internationale Patentklassifikation<sup>6</sup> : <b>A21C 15/02</b></p>	<b>A1</b>	<p>(11) Internationale Veröffentlichungsnummer: <b>WO 99/04639</b></p> <p>(43) Internationales Veröffentlichungsdatum: 4. Februar 1999 (04.02.99)</p>
<p>(21) Internationales Aktenzeichen: PCT/AT98/00178</p> <p>(22) Internationales Anmeldedatum: 23. Juli 1998 (23.07.98)</p> <p>(30) Prioritätsdaten: A 1249/97 23. Juli 1997 (23.07.97) AT</p> <p>(71) Anmelder (für alle Bestimmungsstaaten ausser US): FRANZ HAAS WAFFELMASCHINEN-INDUSTRIE AKTIENGESELLSCHAFT [AT/AT]; Pragestrasse 124, A-1210 Wien (AT).</p> <p>(72) Erfinder; und (75) Erfinder/Anmelder (nur für US): HAAS, Franz, Sen. [AT/AT]; Gerstlgasse 25, A-1210 Wien (AT). HAAS, Johann [AT/AT]; Seitweg 5, A-3400 Klosterneuburg (AT). OBERMAIER, Fritz [AT/AT]; Dr. Gschmeidlerstrasse 14/19, A-3500 Krems (AT).</p> <p>(74) Anwalt: BERGER, Erhard; Siebensterngasse 39, A-1070 Wien (AT).</p>	<p>(81) Bestimmungsstaaten: AL, AM, AT, AU, AZ, BA, BB, BG, BR, BY, CA, CH, CN, CU, CZ, DE, DK, EE, ES, FI, GB, GE, GH, GM, HR, HU, ID, IL, IS, JP, KE, KG, KP, KR, KZ, LC, LK, LR, LS, LT, LU, LV, MD, MG, MK, MN, MW, MX, NO, NZ, PL, PT, RO, RU, SD, SE, SG, SI, SK, SL, TJ, TM, TR, TT, UA, UG, US, UZ, VN, YU, ZW, ARIPO Patent (GH, GM, KE, LS, MW, SD, SZ, UG, ZW), eurasisches Patent (AM, AZ, BY, KG, KZ, MD, RU, TJ, TM), europäisches Patent (AT, BE, CH, CY, DE, DK, ES, FI, FR, GB, GR, IE, IT, LU, MC, NL, PT, SE), OAPI Patent (BF, BJ, CF, CG, CI, CM, GA, GN, GW, ML, MR, NE, SN, TD, TG).</p> <p><b>Veröffentlicht</b> Mit internationalem Recherchenbericht.</p>	

(54) Title: MACHINE FOR FORMING CONES

(54) Bezeichnung: TÜTENFORMMASCHINE

(57) Abstract

The invention relates to a machine (1) for forming rolled-up wafer cones from individual, baked, substantially flat wafer cakes. Several rolls (7) are juxtaposed in a stationary machine housing, along a closed circumferential path. At each roll, a wafer cake, in the form of a hot plastically deformable material, is rolled up between a die (23) and a punch (14) to form a cone, while the rolls (7) move, turning along their path, from the input station to the output station of the cone forming machine. An endless chain (6) of rolls extends along the circumferential path, each roll providing a support frame (8) which supports a punch (14) and a die (23). This support frame is secured to two endless conveyor chains extending parallel to each other, along the circumferential path.

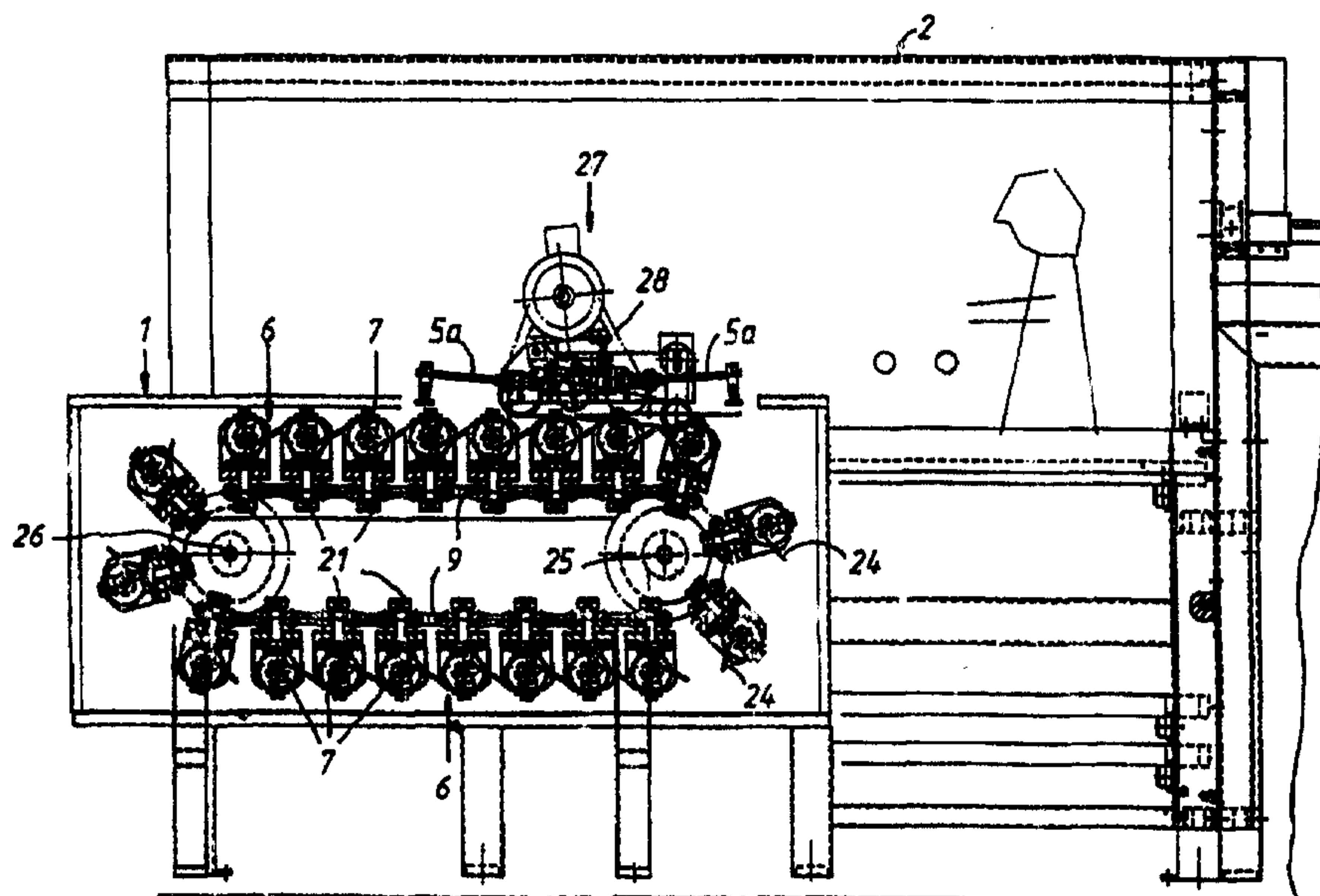

WO 99/04639

PCT/AT98/00178

## Machine for Forming Cones

Technical Domain:

5 The present invention relates to a machine for forming  
rolled-up wafer cones from individual, substantially flat wafer  
cakes that are produced from wafer dough that contains sugar and  
which, for this reason, can be deformed plastically when hot. The  
cone-forming machine has rolls (7) that are arranged around a  
closed, circumferential path, so as to be adjacent to each other;  
10 the wafer cakes are rolled up and the resulting cones are cooled,  
while the rolls move in a stationary machine housing from an  
input station for the wafer cakes to an output station for the  
wafer cones.

15 Prior Art:

Cone-forming machines for manufacturing rolled-up wafer  
cones are in most instances arranged close to the output station  
of a continuously operating wafer baking oven within which  
substantially flat wafer cakes, which are plastically deformable  
20 when hot, are manufactured from wafer dough that contains sugar.  
Whilst they are still warm and plastically deformable, the wafer  
cakes are transferred to the cone-forming machine, within which  
they are rolled up to form cones, after which the resulting cones  
are allowed to cool.

WO 99/04639

PCT/AT98/00178

Elongated, extended wafer baking ovens are used to manufacture wafer cakes; endless chains of baking grippers circulate within these ovens. In each of the baking grippers there is a die that comprises two flat baking plates and is used to manufacture the wafer cakes. These ovens have an elongated oven frame that, on its exterior, is provided with thermal insulation cladding made up of doors and panels. Within the oven frame there is an elongated, rectangular interior space within which the endless chains of baking grippers extend through two transport planes that are situated one above the other and through two guide systems, each of which is situated at an end of the interior space of the particular wafer baking oven. The length, width, and height of this interior space depend on the size of the substantially rectangular baking grippers and the length of the baking gripper conveyor. The size of the baking grippers is matched to the size of the wafer cakes that are to be produced. The width of the interior space is determined mainly by the width of the baking grippers. The diameter of the guide systems of the chains of baking grippers, which determines the vertical spacing of the two transport sections and thus the height of the interior space, depends on the length of the chains of baking grippers. The length of the interior space depends on the number of baking grippers in the chain of baking grippers or on the length of the chain.

WO 99/04639

PCT/AT98/00178

The height of the interior space, together with the feet of the oven frame, determines the position of the upper transport plane of the chain of baking grippers or of the oven.

In the upper transport plane of the oven there is an  
5 output or wafer removal station in which the baked wafer cakes are removed from the opened baking dies, and a dough dispensing station, from which wafer dough is put into the empty, opened dies. These are arranged one after the other in the direction of movement of the chain of baking grippers. Adjacent to the dough  
10 dispensing station, as viewed in the direction of movement of the chain of baking grippers, there is a long baking area that ends just before the wafer removal station and contains the section of the chain of baking grippers that is located in the lower transport plane. The chain of baking grippers moves at a  
15 constant speed, and transports the closed baking grippers through the baking area that is fitted with elongated gas burners. After leaving the baking area, before reaching the wafer removal station, the baking grippers are opened in order to open the baking dies, and are closed once again so as to close the dies  
20 after the dough dispensing station.

During one circuit of a baking gripper, at the dough dispensing station a precisely measured portion of a liquid wafer dough that has a high sugar content is poured onto the lower baking plate of an opened die. After the dough dispensing

WO 99/04639

PCT/AT98/00178

station, the die is closed once again by closing the baking gripper. As the closed baking gripper passes through the baking area, a wafer cake that is plastically deformable when warm is formed in it from the portion of dough contained within it.

5 Before reaching the output station, the die is opened by separating the baking gripper. At the output station, the wafer cake is removed from the open die, and is transferred in a plastically deformable state to the cone forming machine, while the baking gripper is moved on to the dough dispensing station in  
10 order to manufacture the next wafer cake. The time required for the baking gripper to move from the dough dispensing station, through the baking area, to the output station corresponds to the time required to bake the wafer cake.

The capacity of the oven depends mainly on the number  
15 of baking plates that the chain of baking grippers moves at constant speed from the dough dispensing station through the baking area to the output station within the predetermined baking time. The speed of movement of the chain of baking grippers is matched to the distance that must be covered by each baking  
20 gripper as it moves from the dough dispensing station, through the baking area, to the output station in the predetermined baking time. At the output station, the wafer cakes that have been baked in the baking grippers are removed from the opened dies according to a predetermined operating cycle.

WO 99/04639

PCT/AT98/00178

In order to increase the capacity of the oven, it is sufficient to lengthen the chain of baking grippers by a few baking grippers and increase the speed of movement of the chain of baking grippers so that each baking gripper covers the  
5 extended path within the time required to bake the wafer cakes. Lengthening the chain of baking grippers requires only a lengthening of the oven frame in the area of the baking area. When this is done, only the long, interior space that accommodates the chain of baking grippers is lengthened. Its  
10 width and height remain the same. In the same way, the width and height of the oven frame, as well as the position of the upper transport plane of the oven, also remain unchanged. The chain of baking grippers and the oven frame can be lengthened almost without restriction, the only limit being imposed by the maximal  
15 speed at which the chain of baking grippers moves around its path.

These elongated ovens are combined with cone forming machines in which a rigid, rotating platform that contains a plurality of rollers that are associated with the dies of the  
20 oven rotates about a stationary axis of rotation, and in which said rollers are moved by the rotating platform from an input station, through a working section, to an output station. As this is done, the plastically deformable wafer cakes that have been introduced into them at the input station are rolled up

WO 99/04639

PCT/AT98/00178

within them to form cones, after which the cones are allowed to cool in order to increase their inherent stability. The speed at which the rotating platform circulates depends on the spacing between the rolls on the rotating platform on the one hand, and on the spacing of the baking plates in the chain of baking grippers and its speed of circulation, on the other. The diameter of the rotating platform on which the rolls are mounted depends on the cone production time, which begins when the wafer cake is inserted into the roll and ends when the sufficiently cooled cone is stripped from the punch, and on any additional time which is required to move the punch back into the die. Within the rolls, the wafer cones are manufactured within a predetermined cone production time that is required for rolling up a wafer cake and the subsequent cooling of the resulting cone; this time depends mainly on the size of the wafer cake and the size of the cone. This cone production time, together with the speed of movement of the chain of baking grippers, determines the length of the working section of the cone forming machine, and thus the diameter of the circular track followed by the rolls or the size of the rotating platform in which, in most instances, the input station and the output station are diametrically opposed to each other.

The capacity of the cone forming machine is thus determined by the number of rolls that are arranged in the

WO 99/04639

PCT/AT98/00178

rotating platform adjacent to each other along the working section and which are moved from the input station, through the working section, to the output station by the rotating platform within the predetermined cone production time. Thus, the capacity of the cone forming machine depends mainly on the size of the rigid rotating platform, which is matched to the predetermined cone production time and to the speed of rotation of the rotating platform which is determined by the speed of rotation of the rotating platform.

The size of the rotating platform is matched to the maximal baking time of the particular oven.

For reasons of cost, rotating platforms with 8, 10, 12, 14, 16, 18, or 20 rolls are used, depending on the size of the oven. The size of the cone forming machine, or the number of rolls that it contains, is determined by the time required for the baking process and the number of baking plates in the chain of baking grippers, as well as by the time that is required for the cones that have been rolled up to cool. For this reason, any subsequent increase in the number of baking plates in the wafer baking oven is, as a rule, limited by the number of rolls in the cone forming machine.

In most instances, the rigid rotating platform of the known cone forming machines makes provision for two circular frame plates that are perpendicular to the axis of rotation and

WO 99/04639

PCT/AT98/00178

which are connected rigidly to each other by way of axial supporting rods. The rolls are accommodated in the rotating platform between the two frame plates and arranged along the outer side of the rotating platform so as to be spaced apart at equal intervals. The axis of each roll is parallel to the centre axis of the rotating platform and the roll has a die that is cone shaped and coaxial to the axis of the roll; this die has a side entry slot for the wafer cake. The die is secured rigidly to the front frame plate. A punch shaft of the roll, which is coaxial to the axis of the roll, has at its front end a cone-shaped punch and at its rear end a drive wheel. The punch shaft is supported in a carriage that can move axially in the rotating platform so as to be able to rotate but unable to move axially. The carriage rests on two guide columns that are anchored rigidly on the two frame plates and that are parallel to the axis of the roll, and it supports a control element that projects outward. The control elements of the carriages engage in stationary control cam plates that are provided along the outer side of the rotating platform, and derive the axial movement of the punches that are connected to the carriages from the rotation of the rotation platform. In order that the punches can be caused to rotate temporarily, within the area of the input station there is a stationary drive station with a stationary driving device for the punches; the drive wheel on the punch shaft can be engaged with the

WO 99/04639

PCT/AT98/00178

continually rotating drive element by the rotatory movement of the rotating platform.

During one rotation of the rotation platform, at each roll, as it passes the empty section and before it reaches the input station, the carriage is moved axially in order to  
5 introduce the punch into the die. On passing the stationary drive station, the punch that is situated in the die is rotated for a few turns, whilst at the same time the rotating platform moves the roll through the first section of the working section,  
10 and in so doing moves the drive wheel of the punch shaft along on the continuously rotating drive element. The rotating punch draws a wafer cake that has been introduced into the die in the input station, through the side entry slot, and then rolls it up to form a cone. While the rotating platform is moving the roll  
15 through the second section of the working section, the carriage is withdrawn axially, when the punch, together with the wafer cone that is adhering to it, is removed completely from the die, so that the cone that has been formed can cool outside the die as the roll advances; this enhances the inherent stability of the  
20 wafer cone that has been rolled up. At the end of the working section, when the carriage reaches the output station, it is once again displaced axially in order that the cooled and inherently stable wafer cone is stripped off the die. Then, the roll is

WO 99/04639

PCT/AT98/00178

moved through the empty section by the rotating platform, and the production cycle begins once more for the next wafer cone.

Also known are cone forming machines with stationary rotating platforms that are integrated into the output station of an elongated wafer baking oven, in the oven frame. The rigid rotating platform rotates about a vertical axis of rotation that is arranged on the side wall of the oven frame, and its frame plates reach to its output station, above the upper transport plane of the oven. The rolls, which are arranged with their axes vertical, are moved by the rotating platform along a circumferential path that intersects the rectilinear horizontal path of movement of the opened dies at the output station of the oven. The opened dies pass through the output station of the oven with upper baking plates that are arranged so as to slant up to the upper transport plane, and from which the baked wafer cakes are removed by the dies of the rolls. The dies are provided with knives that are positioned in front of their entry slots and slide along the slanting upper baking plates. As the rotating platform turns, the wafer cakes are rolled up in the dies to form cones and in order to cool the cones that are adhering to them, the punches are withdrawn upward from the dies and moved into a raised position. At the output station, the stable cones are released from the raised punches and allowed to fall, with the tips of the cones in front, into an inclined,

WO 99/04639

PCT/AT98/00178

descending chute. The rotating platform is supported so as to be rotatable beneath the upper transport plane of the oven, in the stationary machine frame of the cone forming machine.

Cone forming machines with horizontal rotating platforms are also known; these are arranged at the output station of an elongated oven, adjacent to the frame thereof. The rigid rotating platform turns in the stationary machine frame of the cone forming machine, about a horizontal axis of rotation and moves the rollers, which are arranged with their axes horizontal, along a circumferential path from the input station that is at the level of the upper transport plane of the oven to the output station of the cone forming machine. As the rotating platform is turning, a wafer cake is rolled up to form a cone in each of the rolls, and the resulting cone is moved by displacing the punch horizontally into a cooling position, in which the cone cools until such time as it reaches the output station. At the output station, the cone, which by this time is stable, is released from the punch and allowed to fall down out of the roll.

Between the oven and the cone forming machine there is a transfer device that moves the plastically deformable wafer cakes from the very hot dies of the oven into the much cooler rolls of the cone forming machine; the operating cycle of this transfer device is coordinated with the operating cycle of the cone forming machine and that of the oven.

WO 99/04639

PCT/AT98/00178

The transfer device has a rotating multi-arm star wheel that rotates about a vertical axis; and the ends of its arms, this star wheel has small pickups with which it grasps the wafer cake at its upper side and draws it on an arc shaped horizontal  
5 slideway from the output station of the oven to the input station of the cone forming machine. Each of the pickups lies with only a small amount of pressure on the upper side of the wafer cakes that can be easily deformed when in the plastic state, in order to keep the friction between the wafer cake and the slideway as  
10 low as possible and to avoid the wafer cake becoming deformed when it is moved. The length of the slideway, which describes an arc, together with the speed of rotation of the star wheel, determines the time that is needed to pass through the transfer device, as well as the extent of the changes in the consistency  
15 of the wafer cake, which depends on this.

In order to ensure that the wafer cakes that arrive at the rolls are plastically deformable, it is essential that the amount that the wafer cake cools during its passage through the transfer device, and the reduction of its plastic deformability  
20 that is of necessity linked to this, is kept below a predetermined upper limit. This establishes the maximal length of the slideway as a function of the speed of rotation of the star wheel. The maximal horizontal spacing between the output station of the oven and the input station of the cone forming

WO 99/04639

PCT/AT98/00178

machine, which depends on the radius and the length of the  
slideway, is also established by this.

The slideway is formed from a guide sheet that runs  
horizontally along the curved slideway. In order to bridge small  
5 differences in level between the output station of the oven and  
the input station of the cone forming machine, the guide sheet  
can rise or fall slightly relative to the horizontal. Since  
greater pressure has to be exerted by the pickups that lie on  
their upper surfaces in order to move the wafer cakes across an  
10 inclined guide sheet, in view of the ease with which the hot  
wafer cakes can be deformed. very strict limits have to be set  
with respect to the inclination of said guide sheets.

Also known are cone forming machines with  
horizontally arranged rotating platforms, in which the input  
15 station is arranged on the upper part of the rotating platform,  
close to the upper transport plane of the oven, whereas the  
output station is arranged in the lower part of the rotating  
platform, close to the bottom of the place where the oven is  
installed. At the output station, the rolled wafer cones that  
20 have been manufactured during rotation of the rotating platform  
fall from the cone forming machine on to a lower transport device  
that moves the rolled wafer cones to a cooling device. In these  
cone forming machines, the maximal size of the rotating platform  
is established by the vertical spacing between the lower

WO 99/04639

PCT/AT98/00178

transport device and the input station of the cone forming machine, which is arranged so as to be adjacent to the upper transport plane of the oven. The outside diameter of the rotating platform must be less than the installed height of the oven.

5           Also known are cone forming machines with horizontally arranged rotating platforms, in which the rotating platform rotates about a horizontal axis of rotation that is close to the upper transport plane of the oven, and in which the input station and the output station are similarly arranged close to the upper  
10 transport plane of the oven on the side parts of the rotating platform that are opposite to each other. In these cone forming machines, the maximal size of the rotating platform is established by the vertical spacing between its axis of rotation that is adjacent to the upper transport plane of the oven and the  
15 bottom of the installation site. The radius of the rotating platform is in most instances smaller than the installed height of the oven.

          In the case of cone forming machines with horizontally arranged rotating platforms, it is true that the slideway can  
20 rise slightly towards the transfer device; however, the difference in height that can be overcome by this is very small, so that the enlargement of the rotating platform that can be achieved by this only makes up for the limits imposed by the design of the oven to a limited extent.

WO 99/04639

PCT/AT98/00178

The upper limit for the size of the rotating platform of the associated cone forming machine that is stipulated by the design of the elongated oven is governed by those dimensions of the oven frame that have no effect on the capacity of the particular oven, and to which the width or length of the baking grippers as predetermined by the size of the wafer cake that is to the manufactured are matched. These dimensions cannot be enlarged without disadvantages for the oven.

10 Abstract of the present invention:

It is the objective of the present invention to describe a new cone forming machine with a space saving arrangement of the rolls.

This objective is to be achieved by a cone forming machine that is used to manufacture rolled wafer cones from individual, substantially flat wafer cakes. This cone forming machine has a plurality of rolls that are arranged so as to be adjacent to each other along a closed circumferential path in a stationary machine frame. Within these rolls, the wafer cakes are rolled between a die and a punch to form cones, while the rolls move around their circumferential path from an input station for introducing the wafer cakes into the rolls to an output station where the rolled wafer cones are ejected from the rolls. The cone forming machine according to the present

WO 99/04639

PCT/AT98/00178

invention is characterized in that an endless chain of rolls that extends along the circumferential path is provided, with each roll having a supporting frame for a punch and a die, this frame being secured on two endless conveyors that move along the  
5 circumferential path parallel to each other.

This configuration permits an almost unlimited increase in the number of rolls by lengthening the roller conveyor. The cone forming machine according to the present invention permits an enhancement of its capacity that is matched to its potential  
10 for enhancement.

The working section of the cone forming machine that lies between the input station and the output station can be lengthened as desired, regardless of the speed of movement of the of the oven's chain of baking grippers in order to maintain the  
15 predetermined minimum time that is required to manufacture rolled-up wafer cones that are sufficiently stable with respect to their shape to permit further transportation.

In the cone forming machine according to the present invention, the course of the chain of rolls and thus the shape of the path followed by the rolls can be adapted to the amount of  
20 space available at the site where the oven is installed. The path followed by the roll conveyor contains both rectilinear sections as well as curved sections.

WO 99/04639

PCT/AT98/00178

In the cone forming machine according to the present invention, the position of the output station can be selected regardless of the position of the input station and then matched to the course followed by the chain of rolls. For example, the output station of the cone forming machine can be higher than the input station, so that there is no need for a transport device to follow the cone forming machine in order to overcome this difference in their heights.

According to another feature of the present invention, provision can be made such that at its front end, the punch that is coaxial to the axis of the roll is arranged at the front end of a shaft that is installed in the supporting frame so as to be rotatable and axially immovable, and can be caused to rotate by a drive wheel, while the die that works in conjunction with the punch and is coaxial with the axis of the roll is arranged on a carriage that can move in the supporting frame parallel to the axis of the roll.

This configuration permits a more compact form of the roll with punch shafts that are shorter and supported so as to be stiffer.

According to a further feature of the present invention, provision can be made such that the rolls are arranged along a path that extends in a stationary machine frame, through two guide systems that are spaced apart from each other, and

WO 99/04639

PCT/AT98/00178

through two transport planes that are arranged one above the other; in that the rolls are connected to each other through the two endless conveyor chains that run along a circumferential parallel to each other to form an endless chain of rolls; and in  
5 that a guide system for the chain of rolls is arranged in the area of the input station.

The two transport planes of the chain of rolls that are situated one above the other can be arranged so as to be horizontal or inclined to the horizontal.

10 The present invention will be described in greater detail below on the basis of embodiments that are shown in the drawings are appended hereto. These drawings show the following:

Figure 1: a side view of a first embodiment of a cone forming  
15 machine that is arranged next to an elongated oven, said cone forming machine having horizontally arranged transport planes for the chain of rolls;

Figure 2: a side view of the second embodiment of the cone forming machine that is arranged next to an elongated  
20 oven, with the transport planes for the chain of rolls arranged so as to be inclined to the horizontal;

Figure 3: a vertical cross section through the wafer removal station of the oven and through the input station of

WO 99/04639

PCT/AT98/00178

the cone forming machine that is arranged adjacent thereto;

Figure 4: a side view of a section of the chain of rolls from the upper transport plane of the cone forming machine;

5 Figure 5: a vertical cross section through the chain of rolls in the area out of the upper transport plane of the cone forming machine as in Figure 4;

Figure 6: a side view of this section of the chain of rolls from the lower transport plane of the cone forming machine;

10 Figure 7: a vertical cross section through the chain of rolls in the area of the lower transport plane of the cone forming machine as in Figure 6.

Description of embodiments of the invention

15 Figure 1 shows an elongated cone forming machine 1 that is arranged beside the output station of an extended oven 2 (not shown in the drawing) in which substantially flat wafer cakes (not shown in the drawings) that are to be rolled up to form  
20 cones are manufactured singly from a liquid wafer dough that has a high sugar content.

The elongated oven 2 contains an endless chain of baking grippers that passes through two horizontal transport planes that lie one above the other, the baking grippers 3, 4 of which contain the dies in which the wafer cakes are baked. At

WO 99/04639

PCT/AT98/00178

the wafer removal station, in the area of the upper horizontal transport plane of the chain of baking grippers, the wafer cakes that have been baked are transferred from the opened dies of the opened baking grippers 3 to a transfer device 5 that passes the  
5 wafer cakes to the input station of the cone forming machine 1 whilst they are in a warm and plastically deformable state.

The elongated cone forming machine 1 contains an endless, continually moving chain 6 of rolls that passes through two transport planes that are situated one above of the other,  
10 and which, in the embodiment shown in Figure 1, are arranged horizontally, and in the embodiment shown in Figure 2 slope upwards and away from the input station. When in a warm and plastically deformable state, the wafer cakes are moved singly to the rolls 7 of the chain 6 of rolls and are rolled up in these to  
15 form cones. The cones are allowed to cool, so that they are of a crisp and brittle consistency that is typical of crispy wafers.

The wafer cakes are removed from the lower baking plate 3a of the opened baking grippers 3 of the chain of baking grippers and transported singly by the arms 5a of the transfer  
20 device 5 in a semicircle, from the wafer removal station of the oven 2, shown on the left in Figure 2, to the input station of the cone forming machine 1, shown on the right in Figure 3, where they are moved to a roll 7 of the chain 6 of rolls. The chain 6

WO 99/04639

PCT/AT98/00178

of rolls of the cone forming machine moves in the opposite direction to the chain of baking grippers of the oven 2.

The chain 6 of rolls contains rolls 7 that are arranged one behind the other as viewed in direction in which they circulate, with their own supporting frames 8 and roll axes that are perpendicular to the direction of circulation. The supporting frame 8 has a longitudinal axis that is parallel to the imaginary roll axis; it is connected at its front end 8a that is proximate to the oven to an endless, front conveyor 9 and at its rear end 8b that is remote from the oven 2 to an endless, rear conveyor 10. The upper sides of the supporting frames 8 that are secured to the two conveyors 9, 10 face upward in the upper transport plane of the chain 6 of rolls, and downward in the lower transport plane of the chain 6 of rolls.

At each roll 7, the supporting frame 8 has on its upper side two bearings 11, 12 that are arranged along the imaginary roll axis of the roll; a shaft 13 is supported in these bearings so as to be able to rotate but unable to move axially. The punch 14 of the roll 7 that is attached close to the front end 8a of the supporting frame 8 is secured at the front end of the shaft. In the vicinity of the front bearing 11 a stripper 15 for the rolled up cone is arranged so as to be axially displaceable. At its front end, the stripper has a sleeve 16 that is coaxial with the roll axis, and this extends axially beyond the rear end of

WO 99/04639

PCT/AT98/00178

the punch 14. On the upper side of the stripper 15 there is an actuating element 17, with the aid of which the stripper 15 can be moved axially back and forth along the shaft 13. A drive wheel 18 is secured to the rear end of the shaft 13 adjacent to the rear end of the supporting frame 8, by which the shaft 13, together with the punch 14 can be caused to rotate.

On the upper side of the supporting frame 8 there is a carriage guide 19 that is parallel to the imaginary axis of the roll, and a carriage 20 is guided in this so as to slide, parallel to the axis of the roll. The carriage guide 19 is formed from guide rolls that there arranged on both sides of the carriage 20, one behind the other. On the underside of the carriage 20, close to its rear end, there is an actuating element 21, with the aid of which the carriage can be moved back and forth parallel to the shaft 13. The actuating element 21 extends perpendicular to the axis of the roll from the underside of the carriage 20 and extends through a longitudinal slot 22 in the supporting frame 8 that is parallel to the axis of the roll, downwards and out through the underside of the supporting frame 8. The die 23 that is coaxial to the imaginary axis of the roll is secured at the front end section of the carriage 20; the conical inside of this is open towards the punch 14 at the rear. A guide plate 24 that is tangential to its conical inside is

WO 99/04639

PCT/AT98/00178

secured on the outer side of the die 23 and this is adjacent to the side inlet slot of the die 23 (not shown in the drawing).

The conveyors 9, 10 of the chain of rolls 6 are guided by the front guide wheels that are mounted on a common shaft 25 from the upper transport plane of the chain 6 of rolls into the lower transport plane and by the rear guide wheels that are mounted on a common shaft 26 from the lower transport plane of the chain 6 of rolls into the upper transport plane. The cone forming machine 1 is arranged with the front chain guide systems of its chain 6 of rolls adjacent to the side of the front conveyor guide of the chain of baking grippers of the oven 2. The shaft 25 that supports the front guide wheels of the conveyors 9, 10 is coaxial to the shafts that supports the front guide wheels of the chain of baking grippers and is connected to this through a coupling 26 so as to rotate with it. In this way, the front guide wheels of the chain of rolls and the chain of baking grippers rotate synchronously and move the chain 6 of rolls in the opposite direction to the chain of baking grippers.

A stationary drive station 27 is provided in the area of the input station of the cone forming machine to drive the punches 14 of the roll 7, and when the chain of rolls is moving, the rolls 7 with the drive wheels 18 of their shafts 13 move past this. The drive station 27 is provided with a continuously circulating strip-like drive element 20, of which one section

WO 99/04639

PCT/AT98/00178

extends parallel to the path that is followed by the drive wheels 18 of the chain of rolls 7 when the chain of rolls 6 is moving. When the moving rolls 7 pass the drive station 27, the drive wheels 18 of the rolls 7 that are mounted on the shafts 13 engage with the drive element 28 of the drive station 27, and the shafts 13 and the punches 14 are caused to rotate for as long as they remain so engaged.

In order to roll up a wafer cake, the carriage 20 of the roll 7 is moved into its rear position (Figure 5) by its actuating element 21. When this is done, the die 23 is moved onto the punch 14 from the front, when a gap remains between the conical inner side of the die 23 and a conical outer side of the punch 14. The wafer cake is introduced into this gap over the guide plate 24, through the insertion slot in the die 23 and is then rolled up around the punch 14 to form a cone by the punch which is caused rotate by the drive element 28 of the drive station 27, by the drive wheel 18. The carriage is then moved by its actuating element 21 into its front position (Figure 7). When this is done, the die 23 is withdrawn from the punch 14 far enough that the cone can pass unhindered between the die 23 and the punch 14. Then the stripper 15 is moved into its front position by its actuating element 17, whereby the cone is stripped off the punch 14. While the roll 17 is being moved back to the input station from the output station of the cone forming

WO 99/04639

PCT/AT98/00178

machine 1 by the chain 6 of rolls, the stripper 15 is moved back into its rear output position along the stationary guides of the cone forming machine that act with its actuating element. At the same time, the carriage 21 that bears the roll 23 is moved back into its rear position along the stationary guides that act with its actuating element 22.

20085-134

CLAIMS:

1. A cone forming machine for forming rolled-up wafer cones from individual, substantially flat baked wafer cakes, in which a plurality of rolls are provided, arranged  
5 adjacent to each other along a closed circumferential path in a stationary machine frame, the wafer cakes being rolled up between a die and a punch to form cones, while the rolls move along their circumferential path from an input station where the wafer cakes are introduced into the roll to the  
10 output station where the rolled-up cones emerge from the rolls, wherein an endless chain of rolls that extends along the circumferential path is provided, which in each instance has a supporting frame that supports a punch and a die, said supporting frame being secured to two endless conveyor  
15 chains that circulate moving along the circumferential path parallel to each other.

2. The machine as defined in Claim 1, wherein in each instance the punch is arranged at the front end of a shaft that is arranged so as to be able to rotate in the  
20 supporting frame but unable to move axially therein and which is caused to be rotated by a drive wheel, while the die that works in conjunction with the punch and which is coaxial with the roll is arranged on a carriage that can move in the supporting frame parallel to the axis of the  
25 roll.

3. The machine as defined in Claim 1 or Claim 2, wherein the rolls are arranged along a circumferential path that extends in the stationary machine frame through two guide systems that are arranged so as to be spaced apart  
30 from each other, and through two transport planes that are arranged one above the other; in that the rolls are connected to each other through the two endless conveyor

20085-134

chains that run parallel to each other along the circumferential path to form an endless chain of rolls; and in that a guide system for the chain of rolls is arranged in the vicinity of the input station.

FETHERSTONHAUGH & CO.  
OTTAWA, CANADA

PATENT AGENTS

1/4

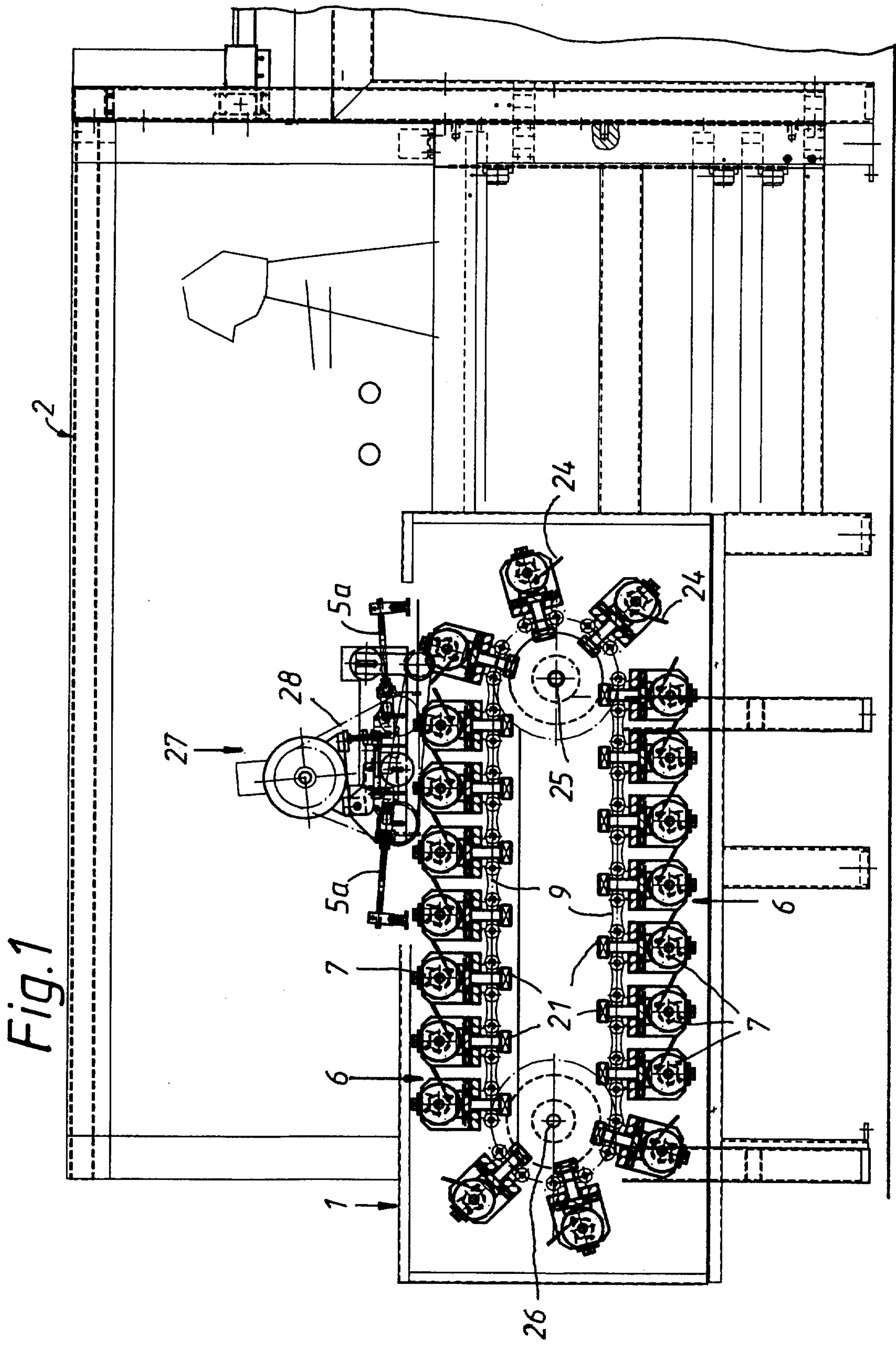
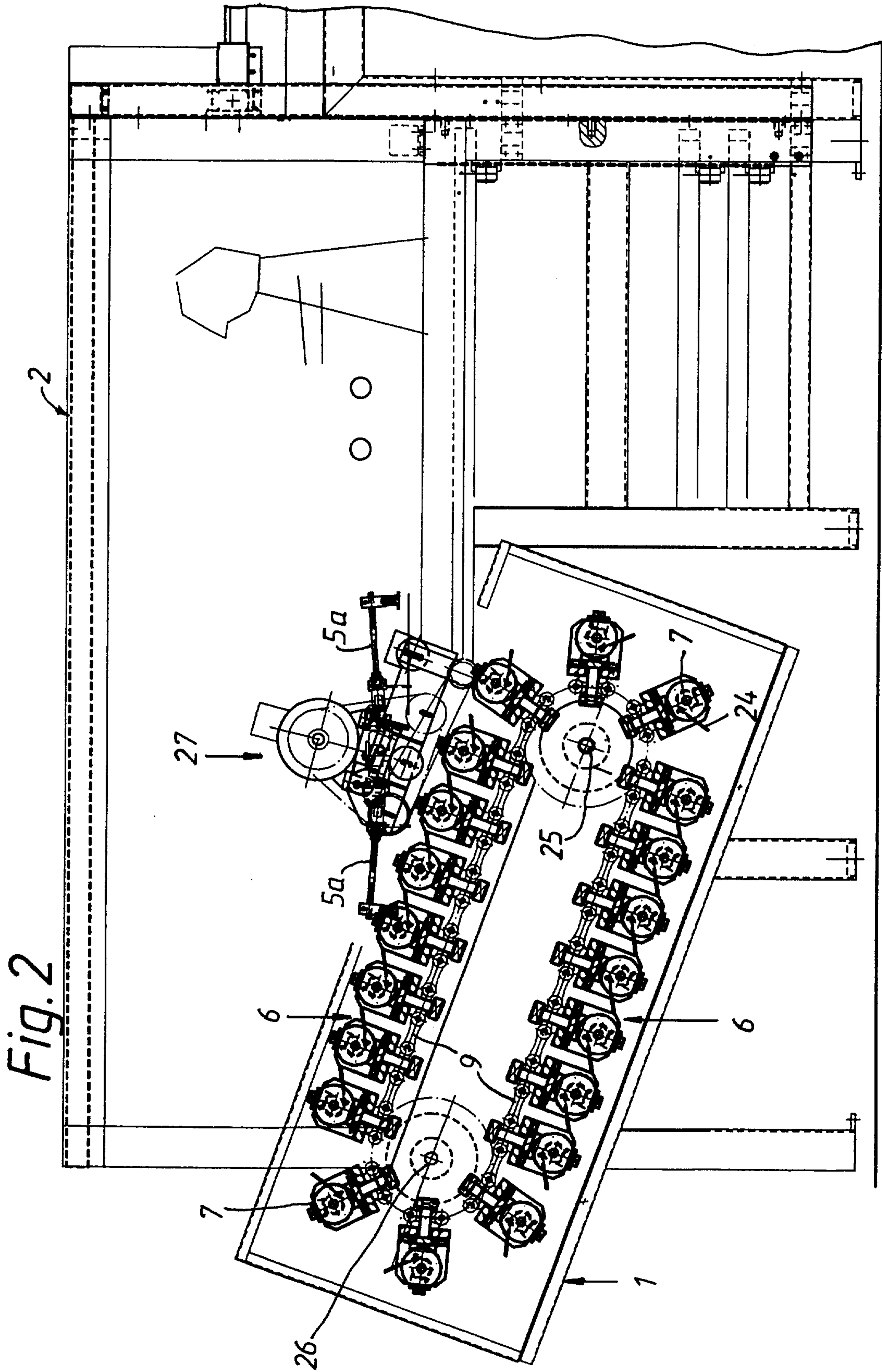

Fig. 1



3/4

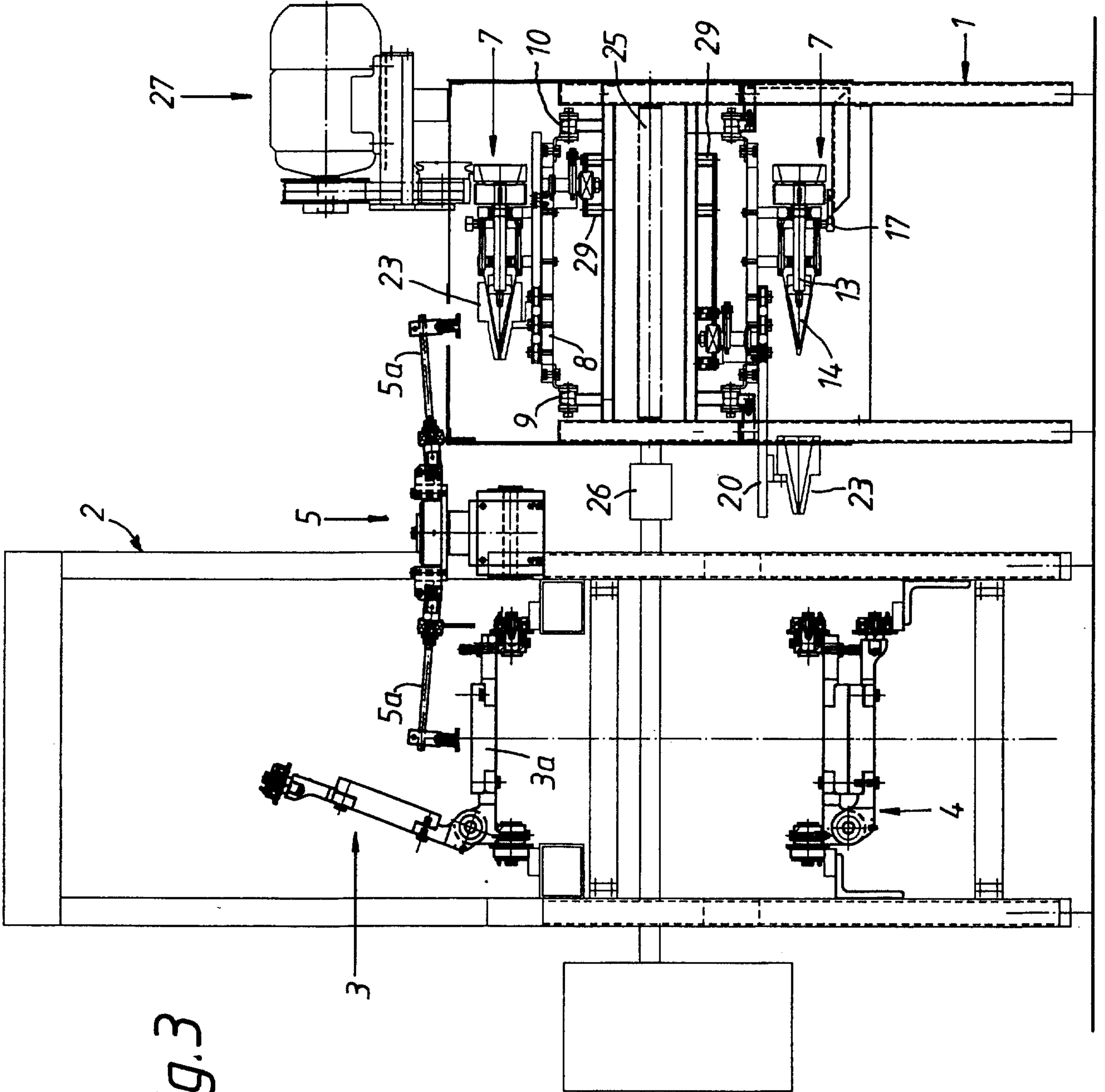

Fig. 3

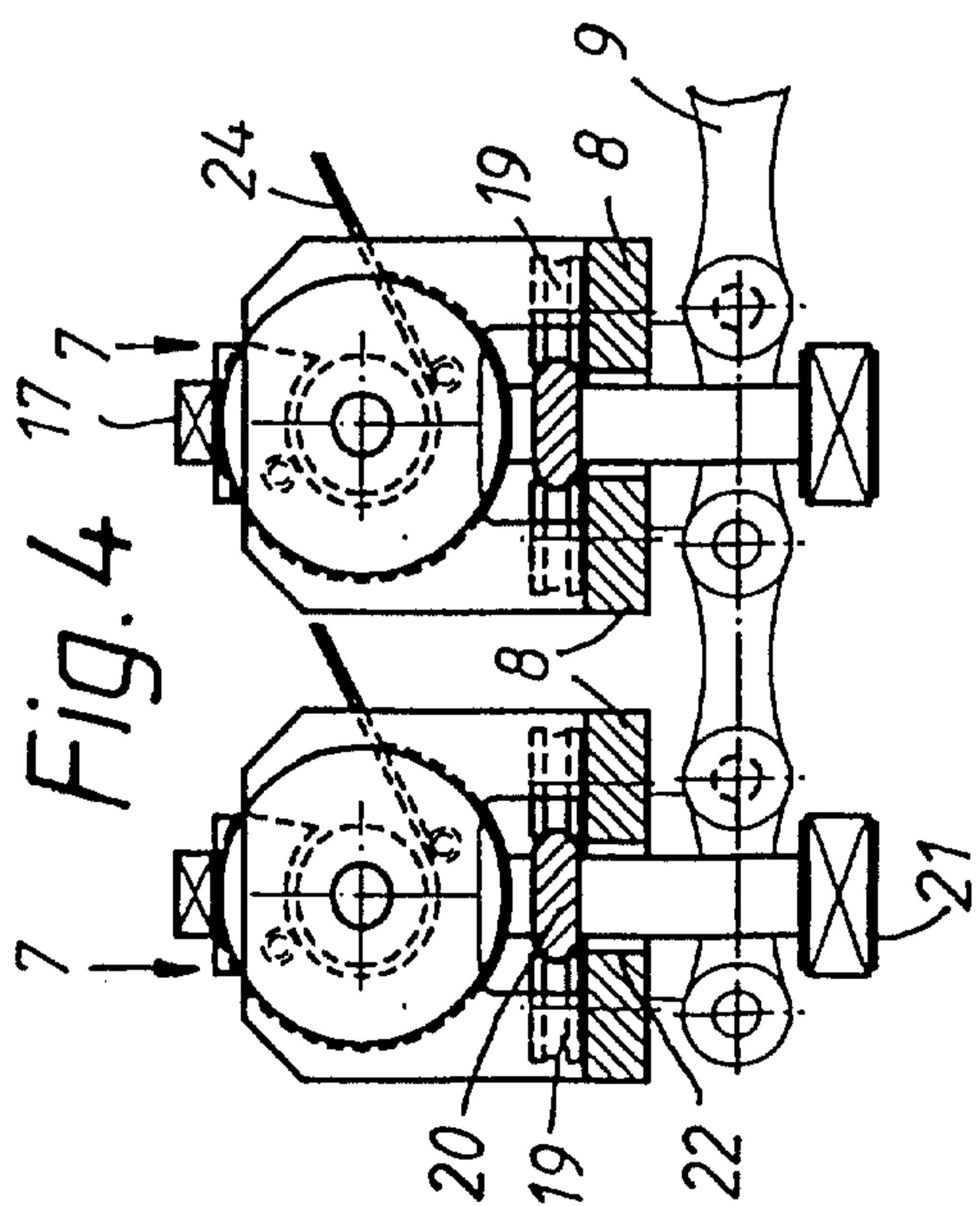

Fig. 5

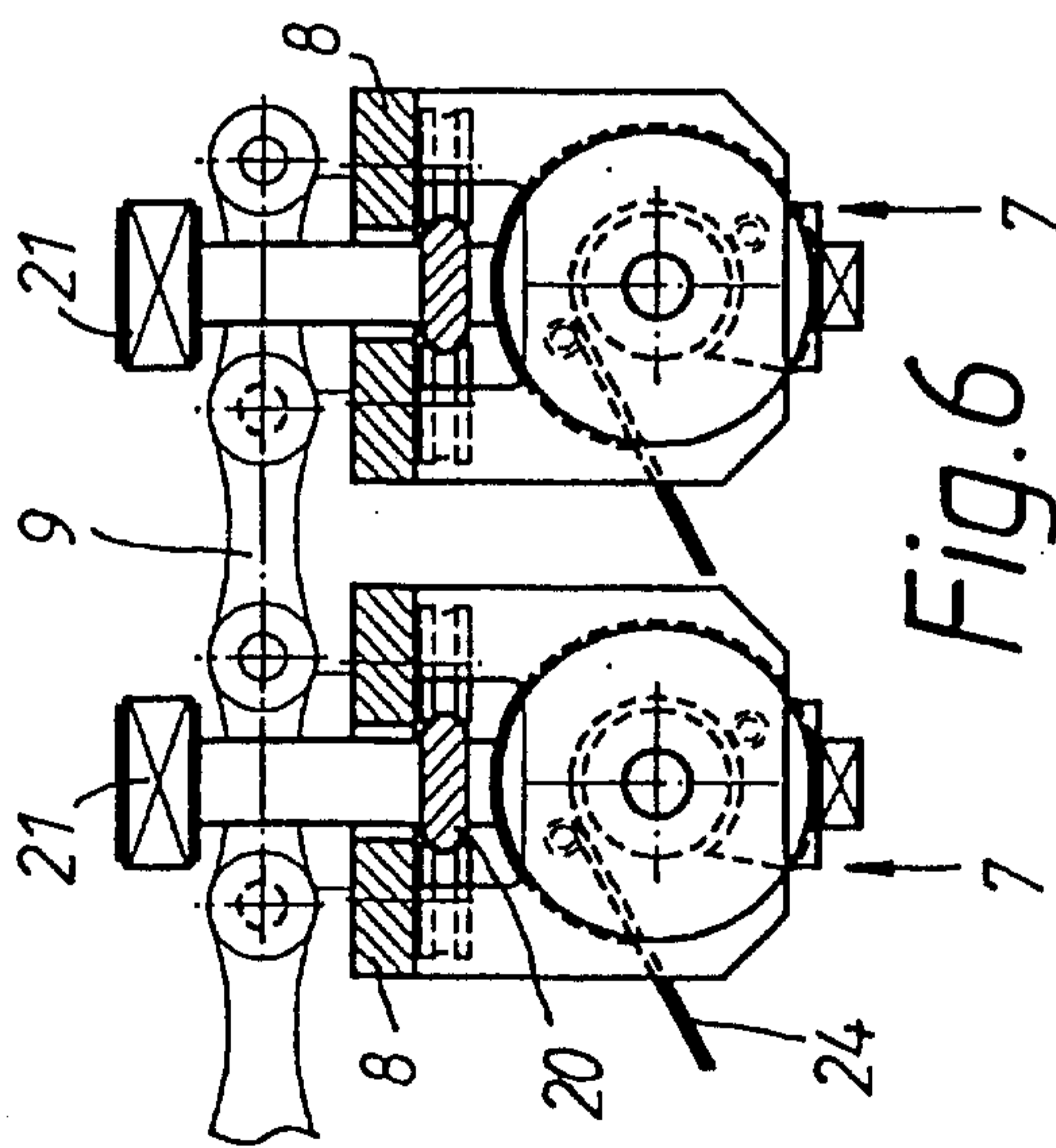
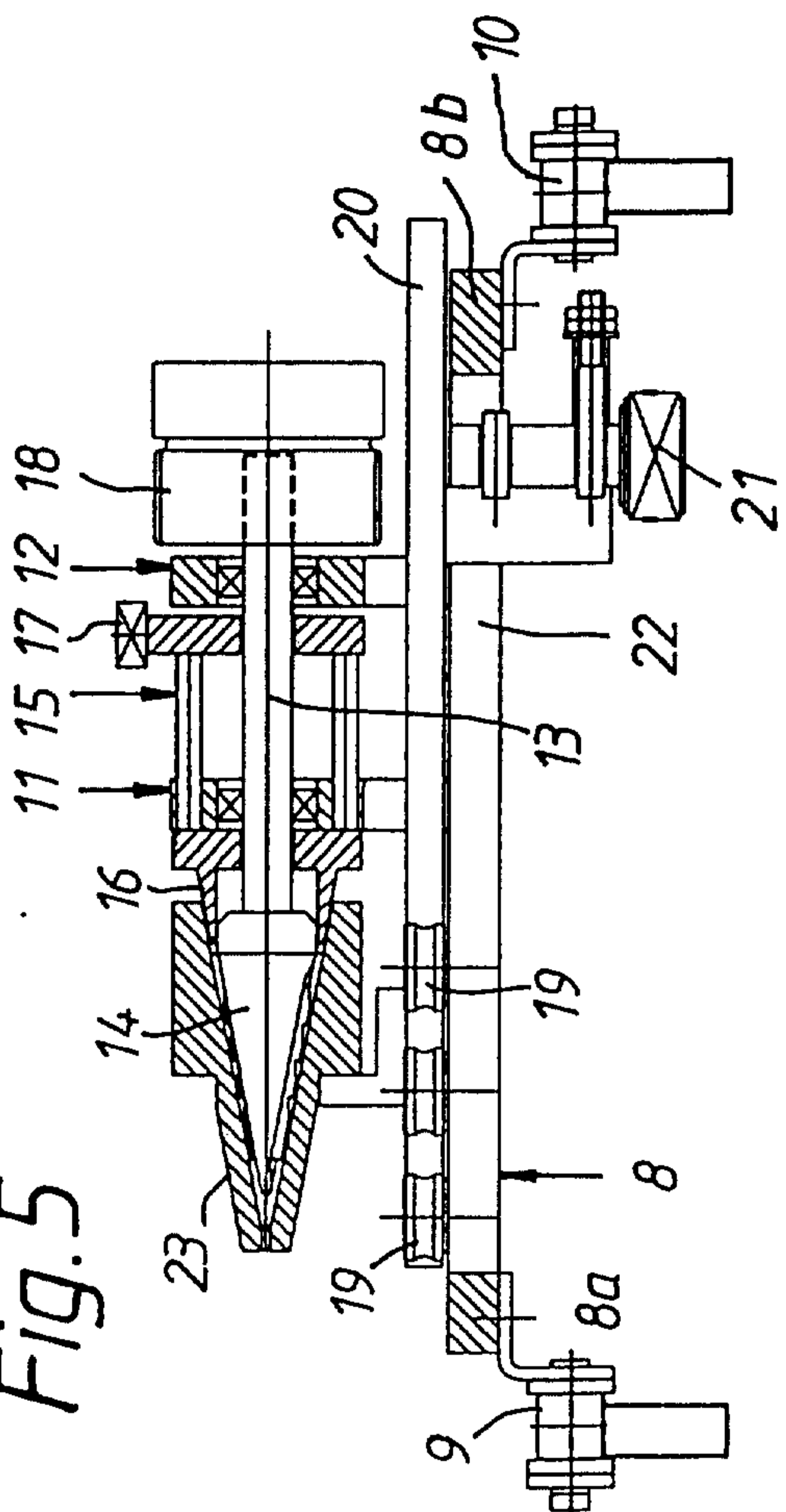

Fig. 6

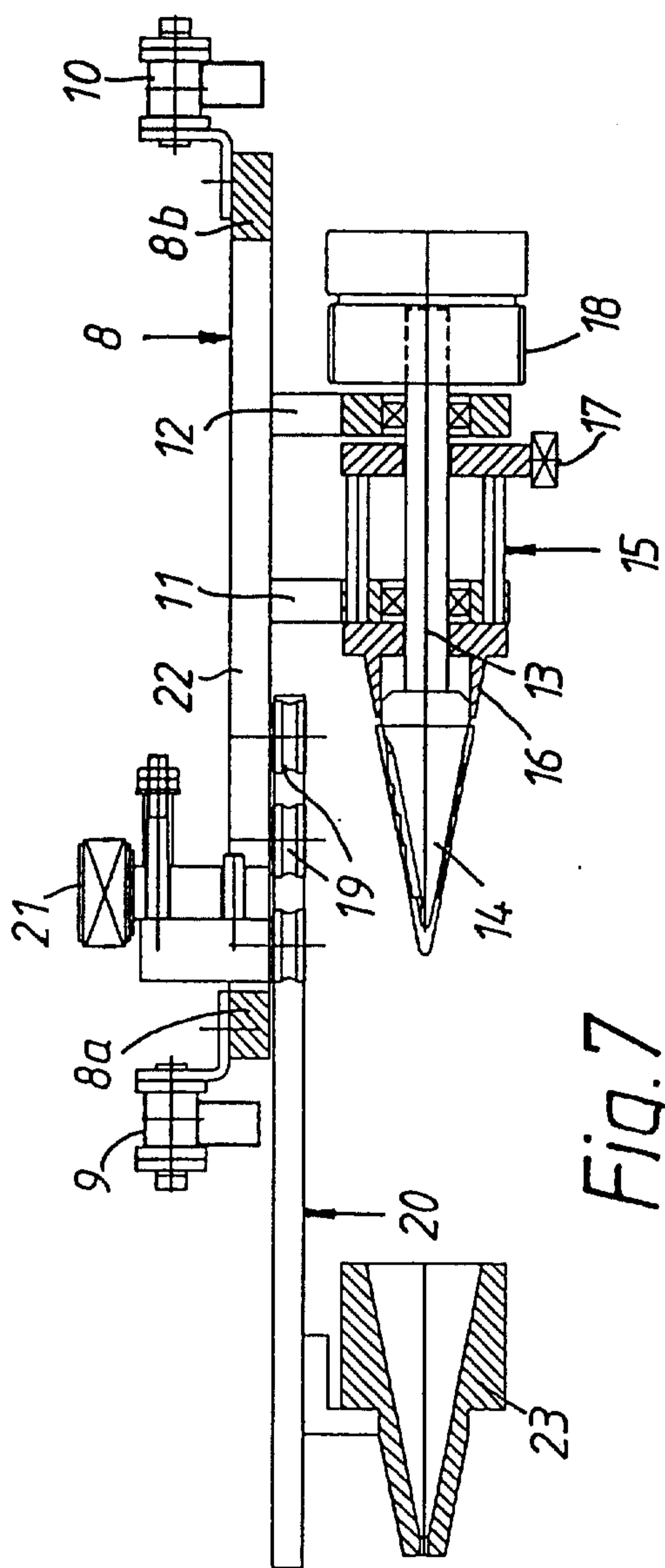

Fig. 7

