

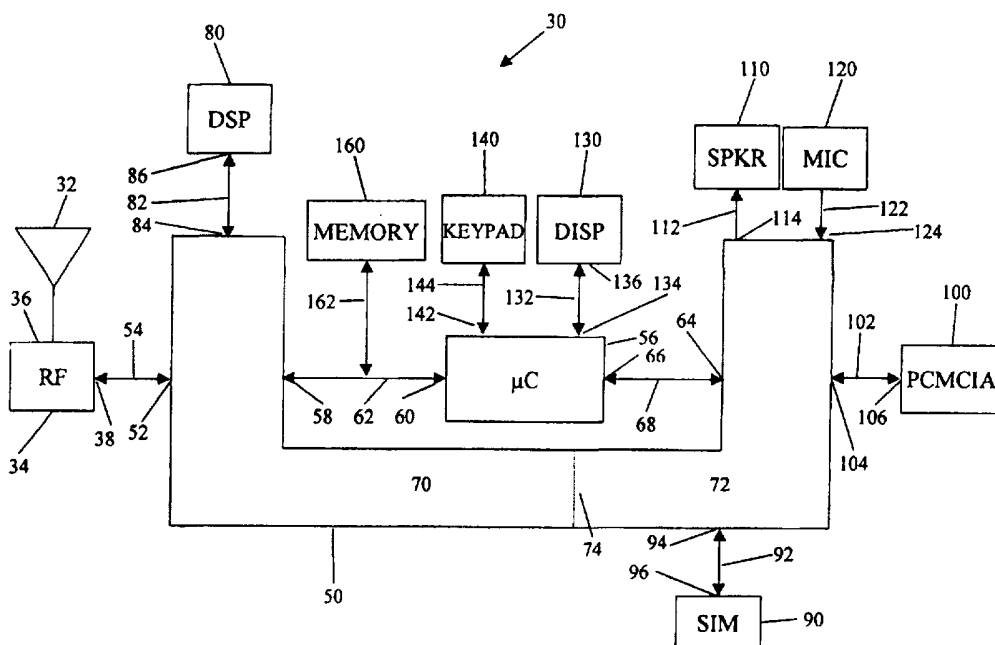

INTERNATIONAL APPLICATION PUBLISHED UNDER THE PATENT COOPERATION TREATY (PCT)

<p>(51) International Patent Classification <sup>6</sup> : <b>H04B 1/38, 1/40</b></p>	<p><b>A1</b></p>	<p>(11) International Publication Number: <b>WO 97/48188</b> (43) International Publication Date: 18 December 1997 (18.12.97)</p>
<p>(21) International Application Number: PCT/US97/09983 (22) International Filing Date: 10 June 1997 (10.06.97) (30) Priority Data: 08/662,641 10 June 1996 (10.06.96) US (71)(72) Applicant and Inventor: CUMMINGS, Mark, R. [US/US]; 348 Camino Al Lago, Menlo Park, CA 94027 (US). (74) Agent: STORWICK, Robert, M.; P.O. Box 386, Mercer Island, WA 98040-0386 (US).</p>	<p>(81) Designated States: AL, AM, AT, AU, AZ, BA, BB, BG, BR, BY, CA, CH, CN, CU, CZ, DE, DK, EE, ES, FI, GB, GE, HU, IL, IS, JP, KE, KG, KP, KR, KZ, LC, LK, LR, LS, LT, LU, LV, MD, MG, MK, MN, MW, MX, NO, NZ, PL, PT, RO, RU, SD, SE, SG, SI, SK, TJ, TM, TR, TT, UA, UG, UZ, VN, ARIPO patent (GH, KE, LS, MW, SD, SZ, UG), Eurasian patent (AM, AZ, BY, KG, KZ, MD, RU, TJ, TM), European patent (AT, BE, CH, DE, DK, ES, FI, FR, GB, GR, IE, IT, LU, MC, NL, PT, SE), OAPI patent (BF, BJ, CF, CG, CI, CM, GA, GN, ML, MR, NE, SN, TD, TG).</p> <p><b>Published</b> <i>With international search report. Before the expiration of the time limit for amending the claims and to be republished in the event of the receipt of amendments.</i></p>	

(54) Title: METHOD AND APPARATUS FOR COMMUNICATING INFORMATION



(57) Abstract

A method and apparatus for communicating information between a remote location and a user. Information from the remote location or the user is received by the inventive apparatus and processed by configurable circuitry (50) to a form that can be received and used by the intended recipient. The configurable circuitry can be changed manually by a human user (140) or remotely through the receipt of the appropriate signals. Accordingly, the apparatus can be reconfigurable to be able to receive information that is transmitted in different forms from those forms that are receivable before reconfiguration.

**FOR THE PURPOSES OF INFORMATION ONLY**

Codes used to identify States party to the PCT on the front pages of pamphlets publishing international applications under the PCT.

AL	Albania	ES	Spain	LS	Lesotho	SI	Slovenia
AM	Armenia	FI	Finland	LT	Lithuania	SK	Slovakia
AT	Austria	FR	France	LU	Luxembourg	SN	Senegal
AU	Australia	GA	Gabon	LV	Latvia	SZ	Swaziland
AZ	Azerbaijan	GB	United Kingdom	MC	Monaco	TD	Chad
BA	Bosnia and Herzegovina	GE	Georgia	MD	Republic of Moldova	TG	Togo
BB	Barbados	GH	Ghana	MG	Madagascar	TJ	Tajikistan
BE	Belgium	GN	Guinea	MK	The former Yugoslav Republic of Macedonia	TM	Turkmenistan
BF	Burkina Faso	GR	Greece	ML	Mali	TR	Turkey
BG	Bulgaria	HU	Hungary	MN	Mongolia	TT	Trinidad and Tobago
BJ	Benin	IE	Ireland	MR	Mauritania	UA	Ukraine
BR	Brazil	IL	Israel	MW	Malawi	UG	Uganda
BY	Belarus	IS	Iceland	MX	Mexico	US	United States of America
CA	Canada	IT	Italy	NE	Niger	UZ	Uzbekistan
CF	Central African Republic	JP	Japan	NL	Netherlands	VN	Viet Nam
CG	Congo	KE	Kenya	NO	Norway	YU	Yugoslavia
CH	Switzerland	KG	Kyrgyzstan	NZ	New Zealand	ZW	Zimbabwe
CI	Côte d'Ivoire	KP	Democratic People's Republic of Korea	PL	Poland		
CM	Cameroon	KR	Republic of Korea	PT	Portugal		
CN	China	KZ	Kazakstan	RO	Romania		
CU	Cuba	LC	Saint Lucia	RU	Russian Federation		
CZ	Czech Republic	LI	Liechtenstein	SD	Sudan		
DE	Germany	LK	Sri Lanka	SE	Sweden		
DK	Denmark	LR	Liberia	SG	Singapore		
EE	Estonia						

Description**METHOD AND APPARATUS FOR COMMUNICATING INFORMATION**5 Technical Field

The present invention relates to methods and apparatus for communicating information, and more particularly, to methods and apparatus for adapting to changing communications services.

10 Background of the Invention

Personal communications is on the brink of an unprecedented expansion of its capabilities. With the advent of advanced personal communications services, such as cellular telephone and low earth orbit (LEO) satellite services, this expansion of capabilities benefits mobile users. Not only does the expansion of capabilities benefit voice communications, but it also benefits data communications, such as might be used with portable computers and other personal data communicators.

A major difficulty with the expansion of services is that a wide variety of different voice and data communications protocols have been proposed. It can be expected that this variety will increase, both world-wide and within a local area. For example, each communications service has its own technical, geographic and feature sets. Technical parameters include frequency(ies), modulation and protocol used, among others. Geographic parameters are dictated by the particular locale, such as footprint. Feature sets describe whether the service is voice, paging, data, or some combination of these.

As a consequence, a given communications device will become less useful as its user attempts to utilize it in areas that have incompatible services. For example, as people who rely on mobile communications move through a day, they can move in and out of different coverage areas and their communications needs will change constantly. Further, even within a local area, a given communications device will gradually become less useful as its built-in capabilities are rendered out-of-date by newer services.

It is clearly undesirable for the individual to have to carry a different communication device for each communication service. Also, few individuals really want to know the details and peculiarities of each of the available communication  
5 service. Most individuals would much rather have seamless service that is simple, convenient and cost-effective.

Therefore, it is advantageous to have a single personal communications device that will reconfigure itself to be compatible with whatever communication service is desired or  
10 needed. This is difficult with today's conventional technology.

Conventional technology solutions use a combination of digital signal processing (DSP) integrated circuits and application-specific integrated circuits (ASICs). The use of a DSP in mobile applications is limited by the requirement to run  
15 on small batteries. This limits the DSP to relatively slow clock rates. If the DSP clock rate is increased, the battery life decreases rapidly. For example, when taking into account memory access, a DSP performing on the order of one hundred operations per sample on a megahertz range signal can require a clock rate  
20 in the gigahertz range. This can consume all the power in small portable batteries in unacceptably brief times.

There are presently approximately two dozen non-compatible wireless communications services, and the number is currently increasing rapidly. There are also about twelve wired  
25 communications services, of which approximately eight are widely used today. The number of services, particularly wireless ones, will continue to increase over the next several decades because technology is evolving rapidly.

Conventional technology approaches use a combination of  
30 analog processing and ASICs to process these high frequency signals. These approaches work well for single service portable devices but do not perform well with multiple services, especially in portable units. When applied to multiple services, the conventional approach results in the use of multiple ASIC  
35 chip sets and analog subsystems. It quite often results in the use of multiple DSPs as well. The result of using conventional technology approaches is a large, heavy, expensive portable unit having short battery life and a range of supported services which is stagnant. In fixed units the problems of battery life

are diminished, but the problems with stagnant service growth are magnified.

#### Summary of the Invention

5           According to one aspect, the invention is an apparatus for providing communication between a user and a remote system. The system includes a communication circuit, a configurable circuit, and a control circuit. The communication circuit communicates with the remote system through transmittal of electromagnetic  
10 energy. The configurable circuit is connected to the communication circuit in order to communicate with the communication circuit using a remote system communication signal. The configurable circuit is further connectable to the user in order to communicate with the user using a user  
15 communication signal. The configurable circuit is configurable in response to a configuration signal. The control circuit produces the configuration signal and is connected to the configurable circuit in order to control the configurable circuit.

20           According to a second aspect, the invention is also a method for providing communication between a user and a remote system. The method includes the steps of a) providing a communication circuit to communicate with the remote system through transmittal of electromagnetic energy, and b) providing a  
25 configurable circuit in order to communicate with the communication circuit using a remote system communication signal. The configurable circuit is further connectable to the user in order to communicate with the user using a user communication signal. Also, the configurable circuit is  
30 configurable in response to a configuration signal.

          Further the method includes the steps of: c) connecting the configurable circuit to the communication circuit; d) providing a control circuit to produce the configuration signal; and e) connecting the control circuit to the configurable circuit in  
35 order to control the configurable circuit.

          According to a further aspect, the invention is an apparatus for providing communication between a user and a remote system. The apparatus includes communication means for communicating with the remote system through transmittal of electromagnetic

energy. The apparatus also includes configurable circuit means connected to the communication circuit for communicating with the communication circuit using a remote system communication signal. The configurable circuit means is further connectable to the user for communicating with the user using a user communication signal. The configurable circuit means is configurable in response to a configuration signal. The apparatus further includes control circuit means for producing the configuration signal. The control circuit means is connected to the configurable circuit means in order to control the configurable circuit means.

#### Brief Description of the Drawings

Figure 1 is a schematic diagram of a preferred embodiment of the invention.

#### Detailed Description of the Preferred Embodiment of the Invention

The approach to the problems described in the background of the invention is to use reconfigurable logic to create highly scalar, deeply pipelined, reconfigurable digital processing systems. This system runs at the data rate of the signal being processed, rather than a multiple of the signal rate, thereby consuming less power, being able to process higher frequency signals, and achieving higher performance. It can be reconfigured in milliseconds, therefore allowing it to support a wide variety of services. When combined with inexpensive microcontrollers and DSPs, such systems can eliminate the need for multiple ASIC chip sets and analog subsystems in order to support multiple services. This results in devices that can deliver system units which are small, lightweight, inexpensive, have long battery life, support multiple services and can have new capabilities added in the field. These new capabilities extend to entirely new services.

The situation for some wired services (for example, broadband CDMA) is the same as for wireless services. However, for other services the signal frequencies can be handled by conventional technology. Nonetheless, with the approach covered by this application, it is possible to support both multiple

wired and wireless services at a much lower marginal cost than with conventional technology.

Both conventional technology and the technology covered by this invention rely on the same underlying chip fabrication processes, and improvements in the underlying processes will benefit both approaches equally. Therefore the relative advantage of the current inventive approach versus the conventional technology will continue over time.

Figure 1 is a schematic diagram of a preferred embodiment of the invention. This structure can be implemented with a variety of physical processes including a printed circuit board, a multi-chip module and a single chip. The inventive communication circuit 30 has an antenna 32 which is connected to a radio frequency (RF) circuit 34 (also known as an RF "front-end" circuit) through an antenna port 36 of the RF circuit 34. The RF circuit 34 also has a bi-directional RF digital input port 38 that can be used to reconfigure it in a manner described subsequently. The antenna 32 is used to communicate with a remote system (not shown) for the purpose of providing communications between the remote system and a user of the inventive communication circuit 30. In some cases, the user can be a human who is communicating audibly with the remote system. In other cases, the user can be an electronic device that is communicating electronically with the remote system.

The RF circuit 34 is adapted to receive a digital control signal through the RF digital input port 38. In response to the digital control signal, the RF circuit 34 can operate in a receive mode or in a transmit mode. In the receive mode the RF circuit 34 can respond to electromagnetic waves which cause a response in the antenna 32, the response being converted to electrical signals through transductive action of the antenna 32. The electrical signals are received through the antenna port 36 in the RF circuit 34. In the transmit mode the RF circuit 34 responds to the digital signals passed through the RF digital input port 38. The RF circuit 34 then transduces the information contained in the electrical signals and produces electromagnetic energy that is passed to the antenna 32 through the antenna port 36.

The inventive communication circuit 30 also includes a configurable circuit 50 that communicates with the RF circuit 34 through a port 52 through a bi-directional line 54. The configurable circuit 50 can, for example, be made from one or more conventional field programmable gate arrays (FPGAs). The configurable circuit 50 is also connected to a microcontroller 56 in two places. A bi-directional port 58 of the configurable circuit 50 is connected to a bi-directional port 60 of the microcontroller 56 through a bi-directional line 62. Also, a bi-directional port 64 of the configurable circuit 50 is connected to a bi-directional port 66 of the microcontroller 56 through a bi-directional line 68.

The configurable circuit 50 can receive configuration signals from the microcontroller 56 through the bi-directional lines 62 and 68. The configuration signals cause the configurable circuit 50 to be partitioned into a remote system configurable circuit 70 and a local interface configurable circuit 72. The partition of the configurable circuit 50 into the remote system configurable circuit 70 and the local interface configurable circuit 72 is symbolized by the imaginary partition 74. The bi-directional port 58 of the configurable circuit 50 is always a part of the remote system configurable circuit 70 and the bi-directional port 64 of the configurable circuit 50 is always a part of the local interface configurable circuit 72, regardless of the way the configurable circuit 50 is partitioned. If desired, it can be advantageous to view the two partitions of the configurable circuit 50 to be separate from one another with a connection between the remote system configurable circuit 70 and the local interface configurable circuit 72.

The configurable circuit 50 is also connected to a digital signal processing (DSP) circuit 80 through a bi-directional line 82 which extends between a port 84 on the remote system configurable circuit 70 and a port 86 on the DSP 80. Although the DSP 80 is shown to be connected to the remote system configurable circuit 70 portion of the configurable circuit 50, it will be understood that the DSP circuit 80 could also be connected to the local interface configurable circuit 72.



The configurable circuit 50 is also connected to a security identification module (SIM) 90 (or other security or identification hardware required) through a bi-directional line 92 which extends between a port 94 on the local interface configurable circuit 72 and a port 96 on the SIM 90. The configurable circuit 50 performs the security and identification functions appropriate to the service or services being supported.

The local interface configurable circuit 72 is also connected to a local interface slot 100 (such as a PCMCIA slot) through a bi-directional line 102 which extends between a port 104 on the local interface configurable circuit 72 and a port 106 on the local interface slot 100.

The local interface configurable circuit 72 is also connected to a speaker 110 through a line 112 which extends between a port 114 on the local interface configurable circuit 72 and the speaker 110. Further, the local interface configurable circuit 72 is also connected to a microphone 120 through a line 122 which extends to a port 124 on the local interface configurable circuit 72.

The microcontroller 56, which may be a Hitachi H8-3002 microcontroller, is connected to a display 130, which may be a touch-input display device. The microcontroller 56 and the display 130 are connected through a bi-directional line 132 which extends between a port 134 on the microcontroller 56 and a port 136 on the display 130. A keypad 140 is also connected to a port 142 on the microcontroller 56 through a line 144.

Finally, a memory 160 is connected through a bi-directional line 162 to the port 58 on the remote system configurable circuit 70 and the port 60 on the microcontroller 56.

In use, the inventive communication circuit 30 is responsive to signals that program the microcontroller 56. The programming signals can be loaded into a program memory on the microcontroller 56 from the memory 160 through the lines 162 and 62 into the port 60. The microcontroller 56 is also responsive to commands and data entered through the keypad 140 and the line 144 into the port 142. The microcontroller 56 can also produce display signals, in response to inputs and its programming, to

be displayed on the display 130 after passage through the line 132 from the port 134 to the port 136.

The microcontroller 56 is programmed to respond to various input signals by changing the configuration of the configurable circuit 50. For example, a portion of the configurable circuit 50 can be configured to respond in predetermined ways to signals received by the remote system configurable circuit 70, for example, by passing audible signals to the speaker 110. Simultaneously, a portion of the configurable circuit 50 can be configured to respond in predetermined ways to signals received by the local interface configurable circuit 72, for example, by causing the antenna 32 to transmit electromagnetic signals to the remote system. If desired the configurable circuit 50 can be configured to communicate with the DSP 80 for special purpose digital signal processing. Further, the configurable circuit 50 can be configured to communicate with the SIM 90 to provide additional security to communications through the inventive communication circuit 30.

The configuration of the configurable circuit 50 can easily be changed over time, as conditions change. For example, the inventive communication circuit 30 can pass from one geographic region to another. This may require the use of an additional communication service based on new modulation/demodulation techniques, protocols and possibly new transmit and receive frequencies. Upon receipt of appropriate reconfiguration signals, the microcontroller 56 will reconfigure the configurable circuit 50, load and/or activate programs in the DSP 130 and microcontroller 56 and, if necessary, reconfigure the RF circuit 34 through ways known to those skilled in the art. The microcontroller 56 may get the configuration and associated information (called TimeWare™) associated programs from memory or from the local interface slot 100 or from a remote system through the RF circuit 34.

While the foregoing is a detailed description of the preferred embodiment of the invention, there are many alternative embodiments of the invention that would occur to those skilled in the art and which are within the scope of the present invention. Included among those embodiments are those

disclosed in United States patent applications filed  
concurrently with the parent of this present application, under  
Express Mail certificates EG952820632US and EG952820615US, and  
having respective serial numbers 60/022,089 and 60/018,103. Also  
5 included among those embodiments are those disclosed in United  
States patent applications filed concurrently with this present  
PCT application, under Express Mail certificates EH447699524US  
and EH447699541US. Accordingly, the present invention is to be  
determined by the following claims.

10

Claims

1. An apparatus for providing communication between a user and a remote system, comprising:
  - 5 a communication circuit to communicate with the remote system through transmittal of electromagnetic energy;
  - a configurable circuit connected to the communication circuit in order to communicate with the communication circuit using a remote system communication signal and the configurable circuit further being connectable to the user in order to
  - 10 communicate with the user using a user communication signal, the configurable circuit being configurable in response to a configuration signal; and
  - a control circuit to produce the configuration signal and
  - 15 being connected to the configurable circuit in order to control the configurable circuit.
  
2. The apparatus of claim 1, wherein the configurable circuit includes a remote system configurable circuit and a local
- 20 interface configurable circuit, the remote system configurable circuit being connected to the communication circuit and the local interface configurable circuit.
  
3. The apparatus of claim 2, wherein the configurable circuit
- 25 includes a reconfigurable logic device, such as a field programmable gate array.
  
4. The apparatus of claim 3, wherein the field programmable gate array is partitioned into the remote system configurable
- 30 circuit and the local interface configurable circuit, the partition being determined by the configuration signal.
  
5. The apparatus of claim 4, wherein the partition is a function of time.
  
- 35 6. A method for providing communication between a user and a remote system, comprising the steps of:
  - a) providing a communication circuit to communicate with the remote system through transmittal of electromagnetic energy;

- b) providing a configurable circuit in order to communicate with the communication circuit using a remote system communication signal and the configurable circuit further being connectable to the user in order to communicate with the user using a user communication signal, the configurable circuit being configurable in response to a configuration signal;
- c) connecting the configurable circuit to the communication circuit;
- d) providing a control circuit to produce the configuration signal; and
- e) connecting the control circuit to the configurable circuit in order to control the configurable circuit.
7. The method of claim 6, wherein the configurable circuit includes a reconfigurable logic device, such as a field programmable gate array.
8. The method of claim 6, further including the step of:
- f) partitioning the field programmable gate array into a remote system configurable circuit and a local interface configurable circuit, the partition being determined by the configuration signal.
9. The method of claim 8, wherein step f) is a function of time.
10. An apparatus for providing communication between a user and a remote system, comprising:
- communication means for communicating with the remote system through transmittal of electromagnetic energy;
- configurable circuit means connected to the communication circuit for communicating with the communication circuit using a remote system communication signal and the configurable circuit means further being connectable to the user for communicating with the user using a user communication signal, the configurable circuit means being configurable in response to a configuration signal; and
- control circuit means for producing the configuration signal, the control circuit means being connected to the

configurable circuit means in order to control the configurable circuit means.

11. The apparatus of claim 10, wherein the configurable circuit means includes a remote system configurable circuit means and a local interface configurable circuit means, the remote system configurable circuit being connected to the communication circuit means and a local interface configurable circuit.

12. The apparatus of claim 11, wherein the configurable circuit means includes a reconfigurable logic device, such as a field programmable gate array.

13. The apparatus of claim 12, wherein the field programmable gate array is partitioned into the remote system configurable circuit means and the local interface configurable circuit means, the partition being determined by the configuration signal.

14. The apparatus of claim 13, wherein the partition is a function of time.

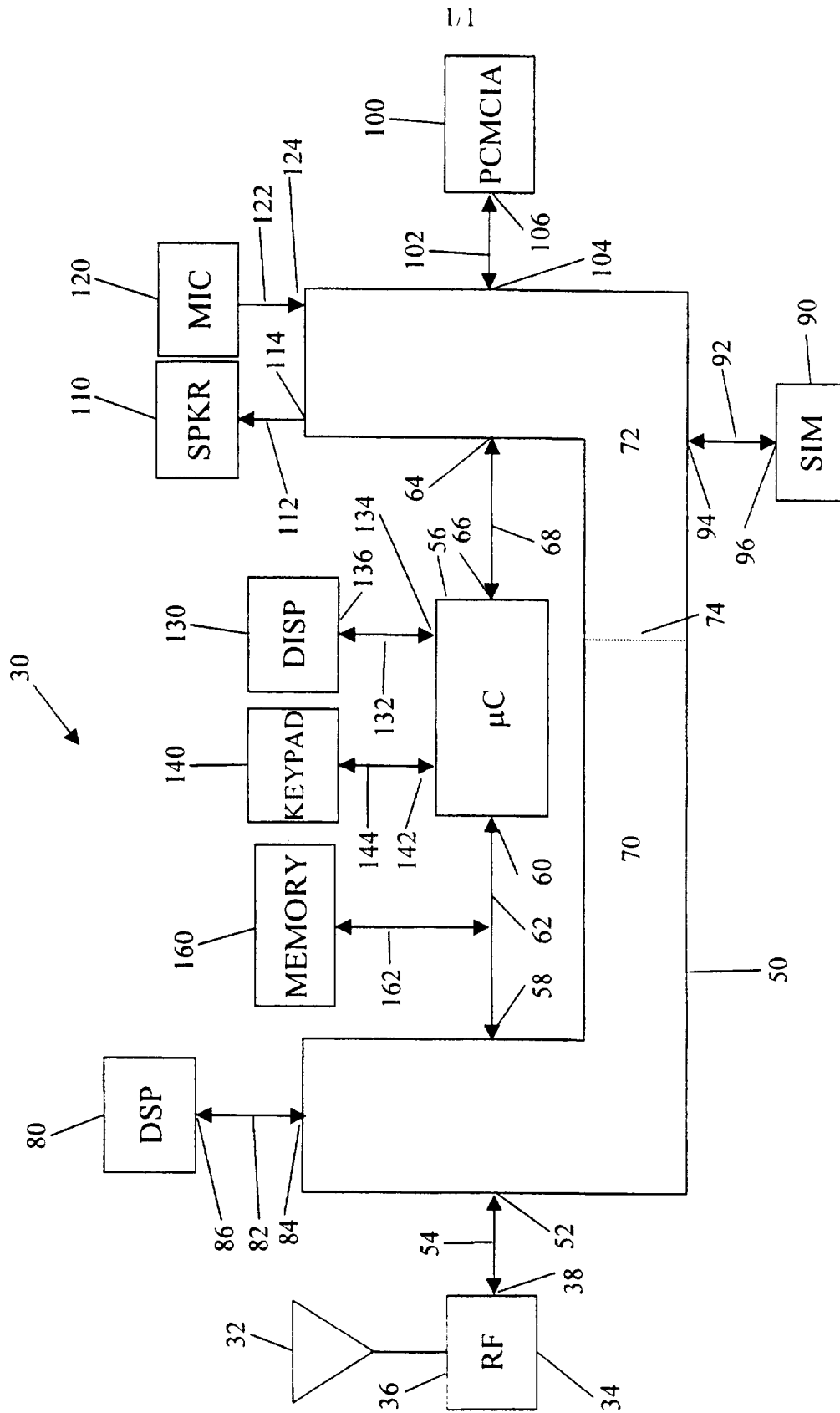

FIG. 1

INTERNATIONAL SEARCH REPORT

International application No.  
PCT/US97/09983

<b>A. CLASSIFICATION OF SUBJECT MATTER</b> IPC(6) :H04B 1/38, 1/40 US CL :375/220; 455/88 According to International Patent Classification (IPC) or to both national classification and IPC		
<b>B. FIELDS SEARCHED</b> Minimum documentation searched (classification system followed by classification symbols) U.S. : 375/220 219; 455/88, 73, 84 Documentation searched other than minimum documentation to the extent that such documents are included in the fields searched NONE Electronic data base consulted during the international search (name of data base and, where practicable, search terms used) Please See Extra Sheet.		
<b>C. DOCUMENTS CONSIDERED TO BE RELEVANT</b>		
Category*	Citation of document, with indication, where appropriate, of the relevant passages	Relevant to claim No.
X --- Y	US 5,237,570 A (SMOLINSKE ET AL.) 17 August 1993, see figures 2 and 5.	1,2,6,10 ----- 3-5,7-9,11-14
Y	US 5,243,593 A (TIMBS) 07 September 1993, see entire document	3-5,7-9,11-14
A	US 4,398,265 A (PUHL ET AL.) 09 August 1983, see figure 1.	1,2,6,10
A	US 4,912,756 A (HOP) 27 March 1990, see figure 2 and 3	1,2,6,10
A	US 5,404,547 A (DIAMANTSTEIN ET AL.) 04 April 1995, see figures 1-3.	1,6,10
<input checked="" type="checkbox"/> Further documents are listed in the continuation of Box C. <input type="checkbox"/> See patent family annex.		
* *A* *E* *L* *O* *P*	Special categories of cited documents: document defining the general state of the art which is not considered to be of particular relevance earlier document published on or after the international filing date document which may throw doubts on priority claim(s) or which is cited to establish the publication date of another citation or other special reason (as specified) document referring to an oral disclosure, use, exhibition or other means document published prior to the international filing date but later than the priority date claimed	*T* *X* *Y* *Z* later document published after the international filing date or priority date and not in conflict with the application but cited to understand the principle or theory underlying the invention document of particular relevance; the claimed invention cannot be considered novel or cannot be considered to involve an inventive step when the document is taken alone document of particular relevance; the claimed invention cannot be considered to involve an inventive step when the document is combined with one or more other such documents, such combination being obvious to a person skilled in the art document member of the same patent family
Date of the actual completion of the international search 28 AUGUST 1997		Date of mailing of the international search report <b>15 OCT 1997</b>
Name and mailing address of the ISA/US Commissioner of Patents and Trademarks Box PCT Washington, D.C. 20231 Facsimile No. (703) 305-3230		Authorized officer TESFALDET BOCURE <i>Jens Bult</i> Telephone No. (703) 305-4735



## INTERNATIONAL SEARCH REPORT

International application No.

PCT/US97/09983

## C (Continuation). DOCUMENTS CONSIDERED TO BE RELEVANT

Category*	Citation of document, with indication, where appropriate, of the relevant passages	Relevant to claim No.
A	US 5,444,869 A (STRICKLIN ET AL.) 22 August 1995, see figure 1.	1,2,6,10

**INTERNATIONAL SEARCH REPORT**

International application No.

PCT/US97/09983

**B. FIELDS SEARCHED**

Electronic data bases consulted (Name of data base and where practicable terms used):

USPTO APS (transceiver#, configurable circuit#, configura? signal#, remote station#, local station#, local configurable circuit, remote configurable circuit) (field programmable gate array# or fpgas)